

400 CONGRESS STREET
MAINE NATIONAL BANK

MECHANICAL

MANUFACTURER'S AGENTS

APPARATUS FOR HEAT TRANSFER, AIR MOVING, FILTRATION AND DISTRIBUTION

RODGERS and ASSOCIATES, INC.

"Carefully attending the Engineer, Contractor and Owner"

P. O. BOX 456

YARMOUTH, MAINE 04096

July 3, 1979

AREA 207, 846-5156
(10 COPIES)

SUBMITTAL DATA - RUSKIN

BRANCH ORDER 90647

PROJECT: MAINE NATIONAL BANK

LOCATION: PORTLAND, MAINE

JOB SPECIFICATION, DWGS.: P. 15B-10, Para. B & C - VOLUME & FIRE DAMPERS

CUSTOMER: JAMES A. McBRADY, INC. - SCARBOROUGH, MAINE P.O.#1374

MECHANICAL CONTRACTOR: P. RUEBEN & COMPANY - PORTLAND, MAINE

GENERAL CONTRACTOR: CONSOLIDATED CONSTRUCTORS - PORTLAND, MAINE

ARCHITECT: ARCHITECTS COLLABORATIVE - CAMBRIDGE, MASS.

ENGINEER: REARDON & TURNER - BOSTON, MASS.

(PLEASE INITIAL AND DATE ANY NOTATIONS ON SUBMITTAL SHEETS)

CONTENTS: DWGS: IBD2-678
MD35-279

REARDON & TURNER
RECEIVED

JUL 20 1979

REFERRED TO _____

ANSWERED _____

RECEIVED

JUL 12 1979

CC & B

APPROVED
W. B. D.

RUSKIN

SPEC
NO. 1BD2-678
Replaces 1BD2-577

**FIRE DAMPER
CURTAIN TYPE
INTERLOCKING BLADE**

TYPE
1BD2

STANDARD CONSTRUCTION

- FRAME: 4 1/2" galvanized steel channel.
- BLADES: Interlocking type galvanized steel.
- ENCLOSURES: 18 gage steel (Types C, CO, & CR). 20 gage steel (Type B).
- FINISH: Mill galvanized.
- FUSIBLE LINK: 212°F Standard. 160°F available at no additional cost.
- MOUNTING: Vertical or Horizontal.



VERTICAL MOUNT

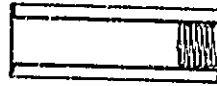

HORIZONTAL MOUNT

FEATURES

Standard model includes 1 1/2 hour UL Fire Damper Label Approved for use in Fire Partitions with ratings up to 2 hours.
Meets all UL and NFPA requirements for PRIMARY FIRE DAMPERS
Gravity operated for Vertical Installation Available with closure springs and latches for horizontal installation.

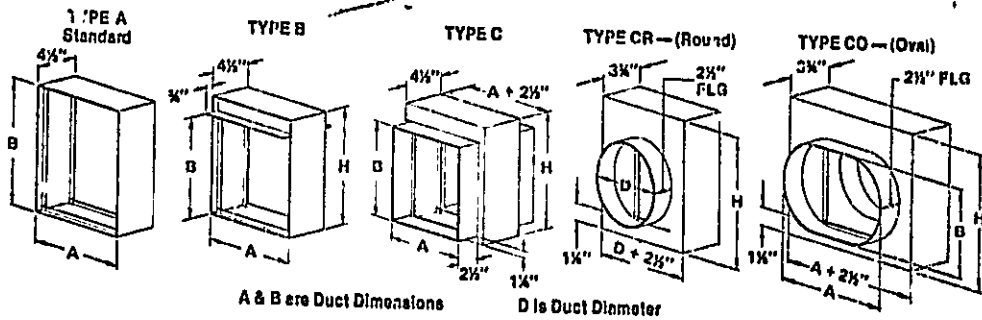

NOTE: For overall Frame Dim. on type B, C, CR, & CO see appropriate 1BD2 Spec sheet.

TYPE A & B will be furnished approx. 1/4" less than given duct dims. TYPE C's will be furnished approx. 1/8" less than given duct dims.

QUAN.	MODEL	SIZE		DUCT DIAM.	TYPE				FUSE LINK TEMP	MTG.		UL
		A-WIDE	B-HIGH		A	B	C	CR		CO	V	
2	1BD2	18	12		X				212	X		X

JOB _____ LOCATION _____
CO: _____ CTOR _____

RUSKIN Mfg. Co. P.O. Box 129 Grandview, Mo. 64030
© RUSKIN MFG. CO. 1978



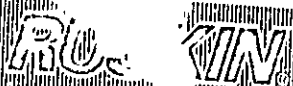

SPEC
NO. MD35 - 279
Replaces MD35 -- 1275

MANUAL DAMPER

TYPE
MD 35

STANDARD CONSTRUCTION

- FRAME: 3 1/2" x 7/8" 16 ga galv steel channel.
 - BLADES: 6" width 16 ga. galv steel on approx 6" centers
 - LINKAGE: Concealed in frame
 - BEARINGS: Cycloloy 800.
 - AXLES: 1/2" Hex.
 - CONTROL SHAFT: 3" x 3/8" sq plated steel.
 - MAXIMUM SIZE: 48" w x 46" h
 - MINIMUM SIZE: OB-6" w x 11" h (2 blades) PB-6" w x 8" h (1 blade)
- For sizes larger than maximum or smaller than minimum, use Model CD-35.

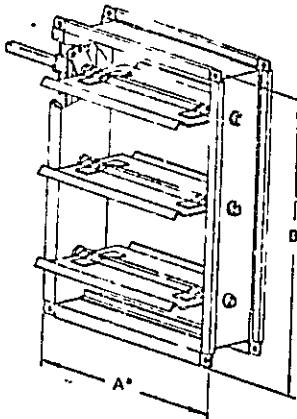

FEATURES

- STEEL CONSTRUCTION - "INTER-LOCKING DESIGN" Entire unit locked together without bolts, screws, or rivets to shake loose
- BEARINGS: "Cycloloy 800," non stick and non corrosive, ensure long life and ease of operation.
- LINKAGE Shake proof. Low maintenance
- AXLES: Positively locked to blade. No screws or welds used, will not shake loose
- FRAME CORNERS: Internally braced to reduce racking.
- CUSTOM TAILORED: To fit any size opening.

Standard construction only available.

NOTE:
For proper operation all dampers must be installed square & free from racking.

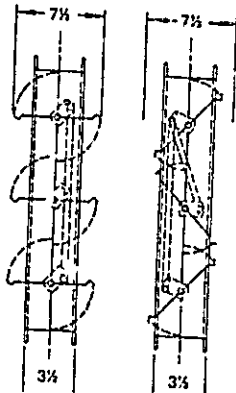

TYPE MD35/PBC PARALLEL BLADE
TYPE MD35/OBC OPPOSED BLADE

*Unit furnished approx. 1/4" smaller than given "opening" dimensions.

QUAN	TYPE	DIMENSIONS		
		A*	B*	
1	MD35/OBC	22	14	w/Hand Quadrant

JOB _____ LOCATION _____
CONTRACTOR _____

RUSKIN Mfg. Co. P.O. Box 129 Grandview, Mo. 64030
© RUSKIN MFG. CO. 1979





APPLICATION FOR PERMIT

PERMIT ISSUED

B.O.C.A. USE GROUP

B.O.C.A. TYPE OF CONSTRUCTION 000515

JUN 27 1979

ZONING LOCATION _____ POR (LAN), MAINE, June 22, 1979

CITY of PORTLAND

To the DIRECTOR OF BUILDING & INSPECTION SERVICES, PORTLAND, MAINE

The undersigned hereby applies for a permit to erect, alter, repair, demolish, move or install the following building, structure, equipment or change use in accordance with the Laws of the State of Maine, the Portland B.O.C.A. Building Code and Zoning Ordinance of the City of Portland with plans and specifications, if any, submitted herewith and the following specifications:

LOCATION 400 Congress St. Fire District #1 , #2

1. Owner's name and address Maine National Bank ... same Telephone

2. Lessee's name and address Telephone

3. Contractor's name and address Consolidated Constructors & Bldr. Telephone 774-2626

4. Architect P.O. box 4056 Sta. # 04101 Plans No. of sheets

Proposed use of building bank No. families

Last use No. families

Material No. stories Heat Style of roof Roofing

Other buildings on same lot

Estimated contractual cost \$ 266,555.00 Fee \$ 1202.50

FIELD INSPECTOR—Mr. GENERAL DESCRIPTION

This application is for: @ 775-5451 To alter bank lobby as per plans
 Ext. 234

Dwelling
 Garage
 Masonry Bldg.
 Metal Bldg.
 Alterations
 Demolitions
 Change of Use
 Other

Stamp of Special Conditions

Sent to Fire Dept. 6-25-79
Rec'd from Fire Dept. _____

NOTE TO APPLICANT: Separate permits are required by the installers and subcontractors of heating, plumbing, electrical and mechanicals.

PERMIT IS TO BE ISSUED TO 1 2 3 4
Other:

DETAILS OF NEW WORK

Is any plumbing involved in this work? Is any electrical work involved in this work?

Is connection to be made to public sewer? If not, what is proposed for sewage?

Has septic tank notice been sent? Form notice sent?

Height average grade to top of plate Height average grade to highest point of roof

Size, front depth No. stories solid or filled land? earth or rock?

Material of foundation Thickness, top bottom cellar

Kind of roof Rise per foot Roof covering

No. of chimneys Material of chimneys of lining Kind of heat fuel

Framing Lumber—Kind Dressed or full size? Corner posts Sills

Size Girder Columns under girders Size Max. on centers

Studs (outside walls and carrying partitions) 2x4-16" O. C. Bridging in every floor and flat roof span over 8 feet.

Joists and rafters: 1st floor 2nd 3rd roof

On centers: 1st floor 2nd 3rd roof

Maximum span: 1st floor 2nd 3rd roof

If one story building with masonry walls, thickness of walls? height?

IF A GARAGE

No. cars now accommodated on same lot, to be accommodated ... number commercial cars to be accommodated ...

Will automobile repairing be done other than minor repairs to cars habitually stored in the proposed building?

APPROVALS BY: DATE

BUILDING INSPECTION—PLAN EXAMINER

ZONING:

BUILDING CODE: M.W. 6/24/79

Fire Dept.:

Health Dept.:

Others:

MISCELLANEOUS

Will work require disturbing of any tree on a public street? .

Will there be in charge of the above work a person competent to see that the State and City requirements pertaining thereto are observed? .. YES ..

Signature of Applicant Phone #

Type Name of above Mr. HOLTON 1 2 3 4

Other
and Address

FIELD INSPECTOR'S COPY

NOTES

7-18-79 Started Alterations - mostly remove debris at this time -

8-31-79 Work progress - have been watching job - Mostly completed outside wall renovations -

11-8-79 Most of exterior work completed - is down the interior Renovations

11-30-79 Completed work -

Permit No. 99/515

Location 408 Congress St.

Owner Mr. McAllister

Date of permit 10-22-79

Approved 10-22-79 [Signature] Lobby

Blank lined area for additional notes or drawings.

5

Grand Re-opening

Starts Tues. NOV. 27th



WIN BAHAMAS TRIP!
Free gifts, prizes, refreshments

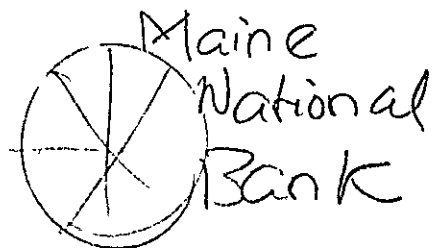



APPLICATION FOR PERMIT

PERMIT ISSUED

B.O.C.A. USE GROUP

B.O.C.A. TYPE OF CONSTRUCTION .. 001012

NOV 7 1979

ZONING LOCATION _____ PORTLAND, MAINE, 11-7-79

CITY of PORTLAND

To the DIRECTOR OF BUILDING & INSPECTION SERVICES, PORTLAND, MAINE

The undersigned hereby applies for a permit to erect, alter, repair, demolish, move or install the following building, structure, equipment or change use in accordance with the Laws of the State of Maine, the Portland B.O.C.A. Building Code and Zoning Ordinance of the City of Portland with plans and specifications, if any, submitted herewith and the following specifications:

LOCATION .. 400 Congress St. Fire District #1 #2

1. Owner's name and address .. Maine National Bank - same .. Telephone 775-7461

2. Lessee's name and address .. Send permit to above attn. Christopher Nichols .. Telephone ..

3. Contractor's name and address .. Borduas Sign Co. - 66 Cove St. .. Telephone 773-0362

4. Architect .. Specifications .. Plans .. No. of sheets .. 1 ..

Proposed use of building .. Bank .. No. families ..

Last use .. same .. No. families ..

Material .. No. stories .. Heat .. Style of roof .. Roofing ..

Other buildings on same lot ..

Estimated contractual cost \$ Fee \$ 12.50 ..

FIELD INSPECTOR—Mr. GENERAL DESCRIPTION

This application is for: @ 775-5451

Dwelling Ext. 234 To ~~erect~~ erect temporary wood banner for 1 month starting Nov. 21, to Dec. 21, as per plan. 5x5

Garage

Masonry Bldg.

Metal Bldg. Stamp of Special Conditions

Alterations

Demolitions

Change of Use

Other

NOTE TO APPLICANT: Separate permits are required by the installers and subcontractors of heating, plumbing, electrical and mechanicals.

PERMIT IS TO BE ISSUED TO 1 2 3 4

Other:

DETAILS OF NEW WORK

Is any plumbing involved in this work? Is any electrical work involved in this work?

Is connection to be made to public sewer? If not, what is proposed for sewage?

Has septic tank notice been sent? Form notice sent?

Height average grade to top of plate Height average grade to highest point of roof

Size, front depth No. stories solid or filled land? earth or rock?

Material of foundation Thickness, top bottom cellar

Kind of roof Rise per foot Roof covering

No. of chimneys Material of chimneys of lining Kind of heat fuel

Framing Lumber—Kind Dressed or full size? Corner posts Sills

Size Girder Columns under girders Size Max. on centers

Studs (outside walls and carrying partitions) 2x4-16" O. C. Bridging in every floor and flat roof span over 8 feet.

Joists and rafters: 1st floor, 2nd, 3rd, roof

On centers: 1st floor, 2nd, 3rd, roof

Maximum span: 1st floor, 2nd, 3rd, roof

If one story building with masonry walls, thickness of walls? height?

IF A GARAGE

No. cars now accommodated on same lot, to be accommodated ... number commercial cars to be accommodated ...

Will automobile repairing be done other than minor repairs to cars habitually stored in the proposed building?

APPROVALS BY: **DATE** **MISCELLANEOUS**

BUILDING INSPECTION—PLAN EXAMINER Will work require disturbing of any tree on a public street? .

ZONING:

BUILDING CODE: Will there be in charge of the above work a person competent to see that the State and City requirements pertaining thereto are observed?

Fire Dept.:

Health Dept.:

Others:

Signature of Applicant .. Christopher Nichols .. Phone # 775-7461

Type Name of above .. Christopher Nichols .. 1 2 3 4

Other Address

FIELD INSPECTOR'S COPY

NOTES

11-8-79 Water at
11-20-79 Sign is up - temp
11-26-80 sign is down -

Permit No. 791 1012
Location 410 Longway St
Owner Mr. Michael Smith
Date of Term 11-9-79
Approved 11-9-79 Temp up good
1/2 barrel for spilling

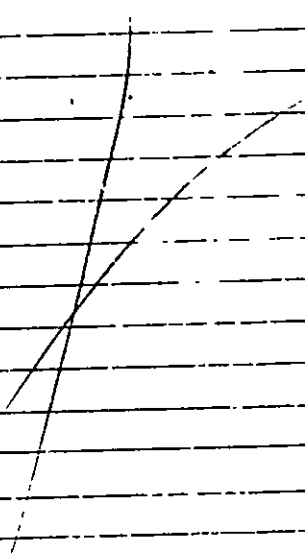

November 13, 1979

The Architects Collaborative Inc.
46 Brattle Street
Cambridge, Mass. 02138

Attn: William Rogers

Re: Maine National Bank Banners - 400 Congress St.

Dear Sir:

Enclosed you will find the approval for the waiver you requested for the above named project. This waiver becomes effective fifteen (15) days after the approval date of 11-8-79.

This waiver will become void only if the use is voluntarily discontinued for twelve (12) consecutive months.

If I may be of any further assistance, please feel free to call this office, City Hall, Building Inspection, Ext 234 or 235.

Very truly yours,

Walter W. Hilton
Chief of Building Inspections

WWH/x

Enclosures

A. J. Wilson, City Manager

11-8-79

Walter W. Hilton, Chief Building Inspector

Waiver Request from 1978 BOCA Building Code
Section 1413.1 Banner and Cloth Signs

STATEMENT OF FACTS

On November 6, 1979, the Building Inspection Department received a written request from the Mains National Bank, 400 Congress Street, with reference to a possible waiver to be allowed to place two (2) cloth banners of combustible material against their building at 400 Congress Street for a period longer than the sixty (60) day requirement under section 1413.1 of the 1978 BOCA Building Code.

Section 1413.1 Banners and Cloth signs reads as follows:

Temporary signs and banners attached to or suspended from a building constructed of cloth or other combustible material shall be strongly constructed and shall be securely attached to their supports. They shall be removed as soon as torn or damaged, and not later than sixty (60) days after erection; except that permits for temporary signs suspended from or attached to a canopy or marquee shall be limited to a period of ten (10) days.

Proposed location is adjacent to an open area and not cutting any structures.

Existing structure is of non-combustible construction.

Section 126.1 of the 1978 BOCA Code

Section 126.1 of the 1978 BOCA Building Code, as amended by the City of Portland, states that the Director of Building Inspection shall have power to recommend modification of any of the provisions of these codes upon application in writing by the owner or lessee, or his duly authorized agent, when there are practical difficulties in the way of carrying out the strict letter of these codes, provided that the spirit of the codes shall be observed, public safety secured, and substantial justice done. The particulars of such recommended modification shall be entered upon the records of the department and a copy signed by the Director of Building Inspection shall be furnished the applicant and the Municipal Officers. Such modification shall become effective fifteen (15) days from and after the date of the recommendation unless a majority of the Municipal Officers shall file with the City Manager within said time written objection to the granting of such modification.

Conclusion

This department hereby approves this waiver subject to the following:

Banners shall be replaced or removed immediately if torn or damaged.

Attached: Letter of request

Approved:

Joseph E. Gray, Jr.
Director of Building Inspections

Walter W. Hilton

Walter W. Hilton
Chief of Building Inspections

Lt. Collins
Fire Prevention



APPLICATION FOR PERMIT
DEPARTMENT OF BUILDING INSPECTIONS SERVICES
ELECTRICAL INSTALLATIONS

Date 10-19, 1979
 Receipt and Permit number A34874

To the CHIEF ELECTRICAL INSPECTOR, Portland, Maine:

The undersigned hereby applies for a permit to make electrical installations in accordance with the laws of Maine, the Portland Electrical Ordinance, the National Electrical Code and the following specifications:

LOCATION OF WORK: 400 Congress Street
 OWNER'S NAME: Maine Nat'l Bank ADDRESS: same

	FEES
OUTLETS:	
Receptacles _____ Switches _____ Plugmold _____ ft. TOTAL <u>1-30</u>	3.00
FIXTURES: (number of)	
Incandescent _____ Fluorescent _____ (not strip) TOTAL <u>63</u>	8.30
Strip Fluorescent _____ ft.	
SERVICES:	
Overhead _____ Underground _____ Temporary _____ TOTAL amperes ..	
METERS: (number of)	
MOTORS (number of)	
Fractional	
1 HP or over	
RESIDENTIAL HEATING:	
Oil or Gas (number of units)	
Electric (number of rooms)	
COMMERCIAL OR INDUSTRIAL HEATING:	
Oil or Gas (by a main boiler)	
Oil or Gas (by separate units)	
Electric Under 20 kws _____ Over 20 kws	
APPLIANCES: (number of)	
Ranges _____ Water Heaters _____	
Cook Tops _____ Disposals _____	
Wall Ovens _____ Dishwashers _____	
Dryers _____ Compactors _____	
Fans _____ Others (denote) _____	
TOTAL	
MISCELLANEOUS: (number of)	
Branch Panels	
Transformers	
Air Conditioners Central Unit	
Separate Units (windows)	
Signs 20 sq. ft. and under	
Over 20 sq. ft.	
Swimming Pools Above Ground	
In Ground	
Fire/Burglar Alarms Residential	
Commercial <u>1</u>	5.00
Heavy Duty Outlets, 220 Volt (such as welders) 30 amps and under	
over 30 amps	
Circus, Fairs, etc.	
Alterations to wires	
Repairs after fire	
Emergency Lights, battery	
Emergency Generators	
INSTALLATION FEE DUE:	
FOR ADDITIONAL WORK NOT ON ORIGINAL PERMIT DOUBLE FEE DUE:	
FOR REMOVAL OF A "STOP ORDER" (304-16.b)	
TOTAL AMOUNT DUE:	16.30

INSPECTION:
 Will be ready on _____, 19__; or Will Call _____
CONTRACTOR'S NAME: Eastern Elec.
ADDRESS: P.O. Box 46, Port., Me.
TEL: 772-6762
MASTER LICENSE NO.: 3279 **SIGNATURE OF CONTRACTOR:** _____
LIMITED LICENSE NO.: _____

INSPECTOR'S COPY — WHITE
 OFFICE COPY — CANARY
 CONTRACTOR'S COPY — GREEN

ROUTING SLIP FROM:
DEPARTMENT OF BUILDING AND INSPECTION SERVICES

ADDRESS 400 Congress St.

Date 10-22-79

- FIRE DEPARTMENT
- PLANNING BOARD
- RENEWAL
- MAINE WAY
- PUBLIC WORKS
- HEALTH
- OTHERS

APPROVED

10/25/79

Douglas T. Hanson
see comments below

DISAPPROVED BY REASON OF:
(quote section of pertinent ordinance or other governing factors)

SPECIAL COMMENTS:

Subject "Exterior Banners" are not located in the Public Right-of-Way or on street frontage and therefore allowable under the Maine Way sign standards
JDM

KEEP SECOND COPY AND RETURN ORIGINAL TO BUILDING & INSPECTIONS



APPLICATION FOR PERMIT

PERMIT ISSUED

B.O.C.A. USE GROUP

B.O.C.A. TYPE OF CONSTRUCTION

000954

OCT 26 1979

ZONING LOCATION B-3

PORTLAND, MAINE, Oct. 22, 1979

CITY OF PORTLAND

To the DIRECTOR OF BUILDING & INSPECTION SERVICES, PORTLAND, MAINE

The undersigned hereby applies for a permit to erect, alter, repair, demolish, move or install the following building, structure, equipment or change use in accordance with the Laws of the State of Maine, the Portland B.O.C.A. Building Code and Zoning Ordinance of the City of Portland with plans and specifications, if any, submitted herewith and the following specifications:

LOCATION 400 Congress Street - back of bank

1. Owner's name and address Maine National Bank - same Fire District #1 #2
 2. Lessee's name and address Telephone 775-7461
 3. Contractor's name and address Coyne Sign Co. - 84 Cove Street Telephone 772-4144
 4. Architect 04104 Telephone 772-4144
 Proposed use of building bank Specifications Plans No. of sheets
 Last use No. families
 Material No. stories Heat Style of roof No. families
 Other buildings on same lot Roofing
 Estimated contractual cost \$ 102.50
 Fee \$ 102.50

FIELD INSPECTOR—Mr.

This application is for.

- Dwelling
- Garage
- Masonry Bldg.
- Metal Bldg.
- Alterations
- Demolitions
- Change of Use
- Other

@ 775-5451
Ext. 234

GENERAL DESCRIPTION

To erect 4 banner type signs, 2 x 48 ft. on back of bank
 Neon letters ~~2x11~~ 11 ft. x 22 on back of bldg.
 back of bank, 3 x 10 ft. 9 in aluminum ^{Standard Special Conditions}
~~sign, ground type~~
 4 x 4 aluminum sign on front of bldg. attached to bldg.

100 Bay View

NOTE TO APPLICANT: Separate permits are required by the installers and subcontractors of heating, plumbing, electrical and mechanicals.

PERMIT IS TO BE ISSUED TO 1 2 3 4

Other:

DETAILS OF NEW WORK

Is any plumbing involved in this work?

Is connection to be made to public sewer?

Has septic tank notice been sent?

Height average grade to top of plate

Size, front

Material of foundation

Kind of roof

No of chimneys

Framing Lumber—Kind

Size Girder

Studs (outside walls and carrying partitions) 2x4-16" O. C. Bridging in every floor and flat roof span over 8 feet

Joists and rafters: 1st floor

On centers: 1st floor

Maximum span: 1st floor

If one story building with masonry walls, thickness of walls?

Is any electrical work involved in this work?

If not, what is proposed for sewage?

Form notice sent?

Height average grade to highest point of roof

solid or filled land?

earth or rock?

Thickness, top

bottom

cellar

Roof covering

Kind of heat

fuel

Corner posts

Sills

Size

Max on centers

3rd

roof

3rd

roof

3rd

roof

height?

IF A GARAGE

No. cars now accommodated on same lot

Will automobile repairing be done other than minor repairs to cars habitually stored in the proposed building?

APPROVALS BY:

BUILDING INSPECTION—PLAN EXAMINER

ZONING: *OK M.A.C. 10/25/79*

BUILDING CODE:

Fire Dept.:

Health Dept.:

Others:

DATE

MISCELLANEOUS

Will work require disturbing of any tree on a public street?

Will there be in charge of the above work a person competent to see that the State and City requirements pertaining thereto are observed?

Signature of Applicant *Paul Coyne*

Type Name of above Coyne Sign Company

Phone # 8888

1 2 3 4

Other and Address

FIELD INSPECTOR'S COPY

NOTES

Sec. 1410.1 Wall signs must be of
a noncombustible material if over 40 sq ft
in Area W

11-28-79 Started erecting signs

11-30-79 Banners used up

1-16-80 Banners down

Permit No. 79/954
Location 1100 Longview St
Owner Mr. National Guard
Date of permit 10-22-79
Approved 10-26-79
difficult to pass signs to address

~~Area W~~



APPLICATION FOR PERMIT
DEPARTMENT OF BUILDING INSPECTIONS SERVICES
ELECTRICAL INSTALLATIONS

Date June 20, 19 79
 Receipt and Permit number A 23968

To the CHIEF ELECTRICAL INSPECTOR, Portland, Maine:

The undersigned hereby applies for a permit to make electrical installations in accordance with the laws of Maine, the Portland Electrical Ordinance, the National Electrical Code and the following specifications:

LOCATION OF WORK: 400 Congress St. - Federal St. side of bank - trailer for
 OWNER'S NAME: Maine National Bank ADDRESS: same tellers

OUTLETS: Receptacles _____ Switches _____ Plugmold _____ ft. TOTAL _____ FEES

FIXTURES: (number of) Incandescent _____ Fluorescent _____ (not strip) TOTAL _____
 Strip Fluorescent _____ ft. _____

SERVICES: Overhead _____ Underground _____ Temporary xx TOTAL amperes 100 3.00

METERS: (number of) _____

MOTORS: (number of) Fractional _____
 1 HP or over _____

RESIDENTIAL HEATING: Oil or Gas (number of units) _____
 Electric (number of rooms) _____

COMMERCIAL OR INDUSTRIAL HEATING: Oil or Gas (by a main boiler) _____
 Oil or Gas (by separate units) _____
 Electric Under 20 kws _____ Over 20 kws _____

APPLIANCES: (number of) Ranges _____ Water Heaters _____
 Cook Tops _____ Disposals _____
 Wall Ovens _____ Dishwashers _____
 Dryers _____ Compactors _____
 Fans _____ Others (denote) _____

TOTAL _____

MISCELLANEOUS: (number of) Branch Panels _____
 Transformers _____
 Air Conditioners Central Unit _____
 Separate Units (windows) _____
 Signs 20 sq. ft. and under _____
 Over 20 sq. ft. _____
 Swimming Pools Above Ground _____
 In Ground _____
 Fire/Burglar Alarms Residential _____
 Commercial _____
 Heavy Duty Outlets, 220 Volt (such as welders) 30 amps and under _____
 over 30 amps _____
 Circus, Fairs, etc. _____
 Alterations to wires _____
 Repairs after fire _____
 Emergency Lights, battery _____
 Emergency Generators _____

FOR ADDITIONAL WORK NOT ON ORIGINAL PERMIT INSTALLATION FEE DUE: _____
 FOR REMOVAL OF A "STOP ORDER" (304-16.b) DOUBLE FEE DUE: _____

TOTAL AMOUNT DUE: 3.00

INSPECTION: Will be ready on _____, 19____; or Will Call xx

CONTRACTOR'S NAME: Philip J. Latini

ADDRESS: 6 Susan Rd. Cape Eliz

TEL.: 799-7879

MASTER LICENSE NO.: 3241 SIGNATURE OF CONTRACTOR: Philip J. Latini

LIMITED LICENSE NO.: _____

INSPECTOR'S COPY — WHITE
 OFFICE COPY — CANARY
 CONTRACTOR'S COPY — GREEN

ELECTRICAL INSTALLATIONS --

Permit Number 23969

Location 410 Congress St. (Trailer on Fuller St.)

Owner Miami Industrial Bank

Date of Permit 6-20-79

Final Inspection 6-22-79

By Inspector Libby

Permit Application Register Page No. 27

INSPECTIONS: Service ✓ by Libby
Service called in _____
Closing-in _____ by _____

PROGRESS INSPECTIONS: _____ / _____ / _____
_____ / _____ / _____
_____ / _____ / _____
_____ / _____ / _____
_____ / _____ / _____

CODE COMPLIANCE COMPLETED
DATE: 6-22-79

REMARKS: This is a temporary feed from the bank to a trailer - not C.M.P.

[Handwritten signature]



APPLICATION FOR PERMIT

PERMIT ISSUED

B.O.C.A. USE GROUP

SEP 12 1977

B.O.C.A. TYPE OF CONSTRUCTION 0799

ZONING LOCATION PORTLAND, MAINE, Sept. 7, 1977

CITY of PORTLAND

To the DIRECTOR OF BUILDING & INSPECTION SERVICES, PORTLAND, MAINE

The undersigned hereby applies for a permit to erect, alter, repair, demolish, move or install the following building, structure, equipment or change use in accordance with the Laws of the State of Maine, the Portland B.O.C.A. Building Code and Zoning Ordinance of the City of Portland with plans and specifications, if any, submitted herewith and the following specifications:

LOCATION ... 400 Congress Street Fire District #1 #2

1. Owner's name and address ... Maine National Bank, same address Telephone

2. Lessee's name and address Telephone

3. Contractor's name and address Fels Company, 390 Presumpscot St. Telephone 773-6431

4. Architect Specifications Plans No. of sheets 1.....

Proposed use of building ... offices No. families

Last use " " No. families

Material No. stories Heat Style of roof Roofing

Other buildings on same lot

Estimated contractual cost \$.. 10,000.00 Fee \$ ~~15.00~~ 15.00

FIELD INSPECTOR—Mr. GENERAL DESCRIPTION

This application is for: @ 775-5451 Alterations to heating and ventilating systems as per plans

Dwelling Ext. 234 on second floor only (ductwork)

Garage

Masonry Bldg. Stamp of Special Conditions

Metal Bldg.

Alterations

Demolitions

Change of Use

Other

NOTE TO APPLICANT: Separate permits are required by the installers and subcontractors of heating, plumbing, electrical and mechanicals.

PERMIT IS TO BE ISSUED TO 1 2 3 4

Other:

DETAILS OF NEW WORK

Is any plumbing involved in this work? Is any electrical work involved in this work?

Is connection to be made to public sewer? If not, what is proposed for sewage?

Has septic tank notice been sent? Form notice sent?

Height average grade to top of roof Height average grade to highest point of roof

Size, front dep. No. stories solid or filled land? earth or rock?

Material of foundation Thickness, top bottom cellar

Kind of roof Rise per foot Roof covering

No. of chimneys Material of chimneys of lining Kind of heat fuel

Framing Lumber—Kind Dressed or full size? Corner posts Sills

Size Girder Columns under girders Size Max. on centers

Studs (outside walls and carrying partitions) 2x4-16" O. C. Bridging in every floor and flat roof span over 8 feet.

Joists and rafters: 1st floor, 2nd, 3rd, roof

On centers: 1st floor, 2nd, 3rd, roof

Maximum span: 1st floor, 2nd, 3rd, roof

If one story building with masonry walls, thickness of walls? height?

IF A GARAGE

No. cars now accommodated on same lot, to be accommodated ... number commercial cars to be accommodated . .

Will automobile repairing be done other than minor repairs to cars habitually stored in the proposed building?

APPROVALS BY:

DATE

MISCELLANEOUS

BUILDING INSPECTION—PLAN EXAMINER Will work require disturbing of any tree on a public street? ..

ZONING:

BUILDING CODE: *D.H. Mac Dowell* Will there be in charge of the above work a person competent to see that the State and City requirements pertaining thereto are observed? YES

Fire Dept.:

Health Dept.:

Others:

Signature Applicant *Wayne S. Jones* Phone # 773-6431

Type Name of above Fels Company 1 2 3

Other and Address

FIELD INSPECTOR'S COPY

NOTES

installed - *[Signature]*

Permit No. 77/8299
Location 408 Lexington St
Owner Mr. Matt Casady
Date of permit 9-7-77
Approved 9-12-77 *[Signature]*

~~_____~~



APPLICATION FOR PERMIT

PERMIT ISSUED

B.O.C.A. USE GROUP

B.O.C.A. TYPE OF CONSTRUCTION 0049

JAN 24 1978

ZONING LOCATION PORTLAND, MAINE, Jan. 24, 1978

CITY of PORTLAND

To the DIRECTOR OF BUILDING & INSPECTION SERVICES, PORTLAND, MAINE

The undersigned hereby applies for a permit to erect, alter, repair, demolish, move or install the following building, structure, equipment or change use in accordance with the Laws of the State of Maine, the Portland B.O.C.A. Building Code and Zoning Ordinance of the City of Portland with plans and specifications, if any, submitted herewith and the following specifications:

LOCATION 400 Congress Street

1. Owner's name and address .. Maine National Bank .. same .. Fire District #1 , #2

2. Lessee's name and address Telephone

3. Contractor's name and address Fels. Co. - 390 Presumpscot St. .. Telephone 773-6431.

4. Architect Specifications Plans No. of sheets

Proposed use of building .. bank .. No. families

Last use .. bank .. No. families

Material No. stories Heat Style of roof

Other buildings on same lot

Estimated contractual cost \$.. 15,000x ..

Fee \$.. 10.00 ..

FIELD INSPECTOR—Mr. GENERAL DESCRIPTION

This application is for: @ 775-5451

Dwelling Ext. 234

Garage

Masonry Bldg.

Metal Bldg.

Alterations

Demolitions

Change of Use

Other alterations to air conditioner & heating system

Alterations to heating and air conditioning unit as per plans. 2 sheets of plans on first floor only

Stamp of Special Conditions

NOTE TO APPLICANT: Separate permits are required by the installers and subcontractors of heating, plumbing, electrical and mechanicals.

PERMIT IS TO BE ISSUED TO 1 2 3 4

Other:

DETAILS OF NEW WORK

Is any plumbing involved in this work? Is any electrical work involved in this work?

Is connection to be made to public sewer? If not, what is proposed for sewage?

Has septic tank notice been sent? Form notice sent?

Height average grade to top of plate Height average grade to highest point of roof

Size, front depth No. stories solid or filled land? earth or rock?

Material of foundation Thickness, top bottom cellar

Kind of roof Rise per foot Roof covering Kind of heat fuel

No. of chimneys Material of chimneys of lining

Framing Lumber—Kind Dressed or full size? Corner posts Sills

Size Girder Columns under girders Size Max. on centers

Studs (outside walls and carrying partitions) 2x4-16" O. C. Bridging in every floor and flat roof span over 8 feet.

Joists and rafters: 1st floor, 2nd, 3rd, roof

On centers: 1st floor, 2nd, 3rd, roof

Maximum span: 1st floor, 2nd, 3rd, roof

If one story building with masonry walls, thickness of walls? height?

IF A GARAGE

No. cars now accommodated on same lot, to be accommodated number commercial cars to be accommodated

Will automobile repairing be done other than minor repairs to cars habitually stored in the proposed building?

APPROVALS BY: DATE

BUILDING INSPECTION—PLAN EXAMINER

ZONING:

BUILDING CODE: OK E.A. 1/28/78

Fire Dept.:

Health Dept.:

Others:

MISCELLANEOUS

Will work require disturbing of any tree on a public street?

Will there be in charge of the above work a person competent to see that the State and City requirements pertaining thereto are observed?

Signature of Applicant .. *Wayne D. Jones* .. Phone # .. same ..

Type Name of above .. Fels. Company ..

Other .. 1 2 3 4

and Address

FIELD INSPECTOR'S COPY

NOTES

45-78 unrefilled

Permit No. 78/9049

Location

Owner

Date of permit

Approved

408 (unrefilled) etc.

Mr. M. J. [unclear]

1-21-78

1-21-78

Adrian [unclear]

to [unclear]

NOTE: The following table is a reconstruction of the data visible in the image. The original document contains a large grid with many blank rows and columns, and some faint, illegible text. The table below represents the structure and any discernible content.

Row	Column 1	Column 2	Column 3
1			
2			
3			
4			
5			
6			
7			
8			
9			
10			
11			
12			
13			
14			
15			
16			
17			
18			
19			
20			
21			
22			
23			
24			
25			
26			
27			
28			
29			
30			
31			
32			
33			
34			
35			
36			
37			
38			
39			
40			
41			
42			
43			
44			
45			
46			
47			
48			
49			
50			
51			
52			
53			
54			
55			
56			
57			
58			
59			
60			
61			
62			
63			
64			
65			
66			
67			
68			
69			
70			
71			
72			
73			
74			
75			
76			
77			
78			
79			
80			
81			
82			
83			
84			
85			
86			
87			
88			
89			
90			
91			
92			
93			
94			
95			
96			
97			
98			
99			
100			



APPLICATION FOR PERMIT

PERMIT ISSUED

B.O.C.A. USE GROUP 0312

MAY 1 1978

B.O.C.A. TYPE OF CONSTRUCTION

ZONING LOCATION _____ PORTLAND, MAINE, April 28, 1978

CITY of PORTLAND

To the DIRECTOR OF BUILDING & INSPECTION SERVICES, PORTLAND, MAINE

The undersigned hereby applies for a permit to erect, alter, repair, demolish, move or install the following building, structure, equipment or change use in accordance with the Laws of the State of Maine, the Portland B.O.C.A. Building Code and Zoning Ordinance of the City of Portland with plans and specifications, if any, submitted herewith and the following specifications:

LOCATION ... 400 Congress St. Fire District #1 , #2

1. Owner's name and address Maine National Bank ... same ... Telephone

2. Lessee's name and address

3. Contractor's name and address Fels Co. - 390 Presumpscot St. Telephone ... 773-6431

4. Architect

Specifications

Plans

No. of sheets

Proposed use of building .. bank

No. families

Last use

No. families

Material

No. stories

Heat

Style of roof

Roofing

Other buildings on same lot

Estimated contractual cost \$.. 15,000.

Fee \$... 60.

FIELD INSPECTOR—Mr. GENERAL DESCRIPTION

This application is for: @ 775-5451 To install 300 ton cooling capacity tower
 Dwelling Ext. 234 on the roof as per plans
 Garage
 Masonry Bldg. (replacement - will be on existing supports)
 Metal Bldg. Stamp of Special Conditions
 Alterations
 Demolitions
 Change of Use
 Other

NOTE TO APPLICANT: Separate permits are required by the installers and subcontractors of heating, plumbing, electrical and mechanicals.

PERMIT IS TO BE ISSUED TO 1 2 3 4
Other:

DETAILS OF NEW WORK

Is any plumbing involved in this work? Is any electrical work involved in this work?

Is connection to be made to public sewer? If not, what is proposed for sewage?

Has septic tank notice been sent? Form notice sent?

Height average grade to top of plate Height average grade to highest point of roof

Size, front depth No. stories solid or filled land? earth or rock?

Material of foundation Thickness, top bottom cellar

Kind of roof Rise per foot Roof covering

No. of chimneys Material of chimneys of lining Kind of heat fuel

Framing Lumber—Kind Dressed or full size? Corner posts Sills

Size Girder Columns under girders Size Max. on centers

Studs (outside walls and carrying partitions) 2x4-16" O. C. Bridging in every floor and flat roof span over 8 feet.

Joists and rafters: 1st floor, 2nd, 3rd, roof

On centers: 1st floor, 2nd, 3rd, roof

Maximum span: 1st floor, 2nd, 3rd, roof

If one story building with masonry walls, thickness of walls? height?

IF A GARAGE

No. cars now accommodated on same lot, to be accommodated ... number commercial cars to be accommodated ...

Will automobile repairing be done other than minor repairs to cars habitually stored in the proposed building?

APPROVALS BY: DATE

BUILDING INSPECTION—PLAN EXAMINER

ZONING:

BUILDING CODE: 0-14-2-X 5/1/78

Fire Dept.:

Health Dept.:

Others:

MISCELLANEOUS

Will work require disturbing of any tree on a public street?

Will there be in charge of the above work a person competent to see that the State and City requirements pertaining thereto are observed? ... Yes.

Signature of Applicant Seth Williams Phone #

Type Name of above Seth Williams 1 2 3 4

Other

and Address

FIELD INSPECTOR'S COPY



APPLICATION FOR PERMIT

B.O.C.A. USE GROUP
 B.O.C.A. TYPE OF CONSTRUCTION 0610
 ZONING LOCATION PORTLAND, MAINE, .. July 20, 1977

PERMIT ISSUED

JUL 20 1977

CITY OF PORTLAND

To the DIRECTOR OF BUILDING & INSPECTION SERVICES, PORTLAND, MAINE
 The undersigned hereby applies for a permit to erect, alter, repair, demolish, move or install the following building, structure, equipment or change use in accordance with the Laws of the State of Maine, the Portland B.O.C.A. Building Code and Zoning Ordinance of the City of Portland with plans and specifications, if any, submitted herewith and the following specifications:

LOCATION 400 Congress St.
 1. Owner's name and address . Maine National Bank . same Fire District #1 , #2
 2. Lessee's name and address Telephone 775-7461
 3. Contractor's name and address ... Consolidated Constr-616 Congress St. Telephone 774-2626
 4. Architect Specifications Plans No. of sheets
 Proposed use of building . bank No. families
 Last use same No. families
 Material No. stories Heat Style of roof No. families
 Other buildings on same lot Roofing
 Estimated contractual cost \$4,000 Fee \$.... 16.00...

FIELD INSPECTOR—Mr. GENERAL DESCRIPTION

This application is for: @ 775-5451
 Dwelling Ext. 234
 Garage
 Masonry Bldg.
 Metal Bldg.
 Alterations
 Demolitions
 Change of Use

Permit to install windows & new 3 x 16
 as per plans. 1 sheet of plans
 5
 Stamp of Special Conditions

Other . install widows in bank
 NOTE TO APPLICANT: Separate permits are required by the installers and subcontractors of heating, plumbing, electrical and mechanicals.

PERMIT IS TO BE ISSUED TO 1 2 3 4
 Other:

DETAILS OF NEW WORK

Is any plumbing involved in this work? Is any electrical work involved in this work?
 Is connection to be made to public sewer? If not, what is proposed for sewage?
 Has septic tank notice been sent? Form notice sent?
 Height average grade to top of plate Height average grade to highest point of roof
 Size, front depth No. stories solid or filled land? earth or rock?
 Material of foundation Thickness, top bottom cellar
 Kind of roof Rise per foot Roof covering Kind of heat fuel
 No. of chimneys Material of chimneys of lining Corner posts Sills
 Framing Lumber—Kind Dressed or full size? Size Max. on centers
 Size Girder Columns under girders
 Studs (outside walls and carrying partitions) 2x4-16" O. C. Bridging in every floor and flat roof span over 8 feet.
 Joists and rafters: 1st floor 2nd 3rd roof
 On centers: 1st floor 2nd 3rd roof
 Maximum span: 1st floor 2nd 3rd roof
 If one story building with masonry walls, thickness of walls? height?

IF A GARAGE

No. cars now accommodated on same lot to be accommodated ... number commercial cars to be accommodated ...
 Will automobile repairing be done other than minor repairs to cars habitually stored in the proposed building?

APPROVALS BY: DATE
 BUILDING INSPECTION—PLAN EXAMINER
 ZONING:
 BUILDING CODE: 0-16-28, 770177
 Fire Dept.
 Health Dept.
 Others:

MISCELLANEOUS

Will work require disturbing of any tree on a public street? ..
 Will there be in charge of the above work a person competent to see that the State and City requirements pertaining thereto are observed?

Signature of Applicant James McKusick Phone # same
 Type Name of above ... James McKusick 1 2 3 4
 Other
 and Address

FIELD INSPECTOR'S COPY

NOTES

2-10-77 Work started - u
installed - m

10-77/6610

Location V.I.G. Long Island

Owner The Metropolitan

Date of permit 7-20-77

Approved 7-21-77

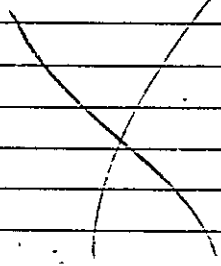

Main body of the document consisting of multiple horizontal lines for notes or data entry, divided into two columns by a vertical line.



APPLICATION FOR PERMIT

B.O.C.A. USE GROUP 0-0509

B.O.C.A. TYPE OF CONSTRUCTION

ZONING LOCATION PORTLAND, MAINE, June 19, 1978

PERMIT ISSUED

JUN 19 1978

CITY OF PORTLAND

To the DIRECTOR OF BUILDING & INSPECTION SERVICES, PORTLAND, MAINE

The undersigned hereby applies for a permit to erect, alter, repair, demolish, move or install the following building, structure, equipment or change use in accordance with the Laws of the State of Maine, the Portland B.O.C.A. Building Code and Zoning Ordinance of the City of Portland with plans and specifications, if any, submitted herewith and the following specifications:

LOCATION ... 400 Congress St. ... Fire District #1 [], #2 []
1. Owner's name and address No. National Bank - same ... Telephone 775-7461
2. Lessee's name and address ... Telephone ...
3. Contractor's name and address Maintenance Dept - Me. Natl Bank ... Telephone same Ext 793
4. Architect ... Specifications ... Plans ... No. of sheets ...
Proposed use of building bank ... No. families ...
Last use same ... No. families ...
Material ... No. stories ... Heat ... Style of roof ... Roofing ...
Other buildings on same lot ...
Estimated contractual cost \$ 1,000 ... Fee \$ 5.00

FIELD INSPECTOR—Mr. Marge

GENERAL DESCRIPTION

This application is for: @ 775-5451 Ext. 234
Dwelling
Garage
Masonry Bldg.
Metal Bldg.
Alterations
Demolitions
Change of Use
Other

To make renovations to 1st floor, mail room, move wall, close door and window sub flooring

Stamp of Special Conditions

Will not interfere with
Mansions of square - non-bearing

NOTE TO APPLICANT: Separate permits are required by the installers and subcontractors of heating, plumbing, electrical and mechanicals.

PERMIT IS TO BE ISSUED TO 1 [x] 2 [] 3 [] 4 []

Other:

DETAILS OF NEW WORK

Is any plumbing involved in this work? ... Is any electrical work involved in this work? ...
Is connection to be made to public sewer? ... If not, what is proposed for sewage? ...
Has septic tank notice been sent? ... Form notice sent? ...
Height average grade to top of plate ... Height average grade to highest point of roof ...
Size, front ... depth ... No. stories ... solid or filled land? ... earth or rock? ...
Material of foundation ... Thickness, top ... bottom ... cellar ...
Kind of roof ... Rise per foot ... Roof covering ...
No. of chimneys ... Material of chimneys ... of lining ... Kind of heat ... fuel ...
Framing Lumber—Kind ... Dressed or full size? ... Corner posts ... Sills ...
Size Girder ... Columns under girders ... Size ... Max. on centers ...
Studs (outside walls and carrying partitions) 2x4-16" O. C. Bridging in every floor and flat roof span over 8 feet.
Joists and rafters: 1st floor ... 2nd ... 3rd ... roof ...
On centers: 1st floor ... 2nd ... 3rd ... roof ...
Maximum span: 1st floor ... 2nd ... 3rd ... roof ...
If one story building with masonry walls, thickness of walls? ... height? ...

IF A GARAGE

No. cars now accommodated on same lot ..., to be accommodated ... number commercial cars to be accommodated ...
Will automobile repairing be done other than minor repairs to cars habitually stored in the proposed building?

APPROVALS BY:

DATE

MISCELLANEOUS

BUILDING INSPECTION—PLAN EXAMINER

Will work require disturbing of any tree on a public street? ..

ZONING:

BUILDING CODE: 014 E 2 6/19/78

Will there be in charge of the above work a person competent

Fire Dept.:

to see that the State and City requirements pertaining thereto

Health Dept.:

are observed?

Others:

Signature of Applicant Philip J. Latini M.B. ... Phone # same

Type Name of above Philip Latini 1 [x] 2 [] 3 [] 4 []

Other ... and Address

FIELD INSPECTOR'S COPY

360 PSIG HALON 1301 SYSTEM CALCULATION ESTIMATE SHEET

SHT 3 OF 8

CLIENT: CONSUMER FIRE - FOR-
MAIN NATIONAL BANK

DRAWING NO. L- 67136B

SHIPPING ORDER: C-77046

DATE: 3-11-77

BY: M. KERNER

HAZARD	DIMENSIONS	VOLUME OR AREA	FLOODING FACTOR	HALON CONCENTRATION		NOZZLES			TOTALS	
				ACTUAL	DESIGN	FLOW RATE	QUAN.	TYPE	FLOW RATE	LBS HALON RECD
① COIN PROCESS. & DISTBIB.	12.5 SWIPE	4806 CU. FT. MAX.	.0206	5%	5%	9.9	1	FAN	9.9	99
② TAPE LIBRARY	24' x 16' x 9'	3436 CU. FT.	.0206	5%	5%	7.2	1	FAN	7.2	72
ANTE ROOM	8' x 16' x 9'	1152 CU. FT.	.0206	5%	5%	2.4	1	FAN	2.4	24
TOTALS									9.6	96
⑤ BURSTER RM	26' x 12' x 9'	2808 CU. FT.	.0206	5%	5%	5.8	1	FAN	5.8	58
ULLAGE FOR 125" CYL. WITH 100" HALON 1301 =		1378								

QUANTITY OF HALON 1301 DELIVERED 100 LBS.

<p>① $\frac{1378}{1378 + 852} = .62 + 1.236 = 1.86 \times 100 = 186$ (2230)</p>	<p>③ $\frac{1378}{1378 + 1003} = .58 + 1.236 = 1.81 \times 100 = 181$ (2381)</p>
<p>② $\frac{1378}{1378 + 2121} = .39 + 1.236 = 1.63 \times 100 = 163$ (3499)</p>	<p>+ = + 1.236 = x 100 =</p>

NOZZLE AT POINT	B	D	E	F
TOTAL REMAINING FACTOR TO WORK WITH	186	163	163	181
MINUS FACTOR LOSS THRU PIPE	11	22	24	16
EQUALS SUB TOTAL FACTOR	175	141	139	165
ELEV. CORRECTION ± .43/FT.	-3	-3	-3	-3
TOTAL REMAINING FACTOR AT NOZZLE	172	138	136	162
DISCHARGE RATE	19.3	12.6	12.3	17.2
ULLAGE CORRECTION FACTOR	.97	.79	.79	.94
SPECIFIC RATE	18.7	9.9	9.7	16.2
FLOW RATE	9.9	2.4	7.2	5.8
ORIFICE SIZE	#32	#27	#37	#26
NOZ. PIPE THD. SIZE	1 1/4"	3/4"	1 1/4"	1"
PART NUMBER	258879	258798	258824	258808

①

②

③

MK

PIPE ULLAGE & FACTOR DROPS

COH. PROCES. & DISTRIB.

①

PIPE SECTION	PIPE SIZE	FLOW RATE	ACTUAL LENGTH X CU. IN. PER FOOT	EQUIVALENT PIPE LENGTH X FACTOR DROP PER EQUIV. FT.	FACTOR DROP	TOTAL DROP AT NOZZLE	QTY NOZZLE
A	2"	9.7	120 x 1 = 120	36' x .037 = 1.33			
A-B	1 1/2"	9.9	30 x 24.4 = 732	68' x .148 = 10.06 + 1.33 = 11.39		11 @ B	1
			852				

TAPE LIBRARY & ANTE ROOM

②

A	2"	9.6	120 x 1 = 120	36' x .035 = 1.26			
A-D	1 1/2"	9.6	65 x 24.4 = 1586	147' x .138 = 20.28 + 1.26 = 21.55		22 @ D	1
D-E	1 1/2"	7.2	17 x 24.4 = 415	30' x .074 = 2.22 + 21.55 = 23.77		24 @ E	1
			2121				

BURSTER ROOM

③

A	2"	5.8	120 x 1 = 120	36' x .012 = .43			
A-C	1 1/2"	5.8	3 x 24.4 = 73.2	12' x .047 = .56 + .43 = .99			
C-F	1 1/4"	5.8	45 x 18 = 810	137' x .111 = 15.20 + .99 = 16.19		16 @ F	1
			1003				

RECEIVED
 MAR 17 1971
 DEP. OF BUILDING INSPECTION
 CITY OF PORTLAND
 MK

360 PSIG HALON 1301 SYSTEM CALCULATION ESTIMATE SHEET

CLIENT: CONSUMER FIRE - FOR -
MAN NATIONAL BANK

DRAWING NO. L- 671368
SHIPPING ORDER: C-71046
DATE: 3-11-77
BY: M. KEENER

HAZARD *	DIMENSIONS	VOLUME OR AREA	FLOODING FACTOR	HALON CONCENTRATION		NOZZLES			TOTALS		
				ACTUAL	DESIGN	FLOW RATE	QUAN.	TYPE	FLOW RATE	LBS. HALON REQD	
COMPUTER RM.	IR. SHAPE	20,777 CU. FT. MAX	.0206	5%	5%	14.3	3	3/8" IT	42.8	428	
UNDERFLOOR	IR. SHAPE	2715 CU. FT. MAX	.0206	5%	5%	1.9	3	3/8" IT	5.6	56	
COAT ROOM	12' x 10' x 8'	960 CU. FT.	.0206	5%	5%	2.0	1	FAN	2.0	20	
<p>ULLAGE FOR 200% C.Y. WITH 168# HALON 1301 = 1989 x 3 = 5967</p>											
QUANTITY OF HALON 1301 DELIVERED <u>504</u> LBS.						TOTALS		<u>50.4</u>	<u>504</u>		
$\frac{5967}{5967 + 6570} = .48 + 1.236 = 1.71 \times 100 = 171$ <p>(12,537)</p>						+		=	+1.236 =	X 100 =	
+						=		+1.236 =	X 100 =		
+						=		+1.236 =	X 100 =		
NOZZLE AT POINT	F	G	I	J	K	M	N				
TOTAL REMAINING FACTOR TO WORK WITH	171	171	171	171	171	171	171				
MINUS FACTOR LOSS THRU PIPE	27	24	32	35	21	31	30				
EQUALS SUB TOTAL FACTOR	144	147	133	136	150	140	141				
ELEV. CORRECTION ± .43/FT.	-3	-3	-3	-3	+3	+3	+3				
TOTAL REMAINING FACTOR AT NOZZLE	141	144	130	133	153	143	144				
DISCHARGE RATE	13.2	13.7	11.2	11.7	15.3	13.5	13.7				
ULLAGE CORRECTION FACTOR	.86	.86	.86	.86	.86	.86	.86				
SPECIFIC RATE	11.4	11.8	9.6	10.0	13.2	11.6	11.8				
FLOW RATE	2.0	14.3	14.3	14.3	1.9	1.9	1.9				
ORIFICE SIZE	#18	#48	#47	#47	#17	#18	#18				
NOZ. PIPE THD. SIZE	3/4"	2"	1 1/2"	1 1/2"	3/4"	3/4"	3/4"				
PART NUMBER	258795	259083	258	787	258792	258	743				
	COAT RM.	COMP. RM.		UNDERFLOOR						MK	

**360 FSIG HALON 1301 SYSTEM
CALCULATION ESTIMATE SHEET**

CLIENT: CONSUMER FIRE - FOR -
MAINE NATIONAL BANK

DRAWING NO. L- 67136B
SHIPPING ORDER: C-77046
DATE: 3-11-77
BY: M. KAENER

HAZARD	DIMENSIONS	VOLUME OR AREA	FLOODING FACTOR	HALON CONCENTRATION		NOZZLES			TOTALS	
				ACTUAL	DESIGN	FLOW RATE	QUAN	TYPE	FLOW RATE	LBS. HALON REQD
ROOM #1419	36'x21'x8'	6058 CU.FT.	.0206	5%	5%	12.5	1	SP17	12.5	125
UNDERFLOOR	36'x21'x1'	756 CU.FT.	.0206	5%	5%	1.6	1	SP17	1.6	16
ULLAGE FOR 200" CYL. WITH 168# HALON 1301 = 1989										
QUANTITY OF HALON 1301 DELIVERED <u>166</u> LBS.						TOTALS		<u>14.1</u>	<u>141</u>	
$\frac{1989}{1989 + 2653} = .43$				$+ 1.236 = 1.66 \times 100 = 166$		+		$+ 1.236 =$		$\times 100 =$
+				$+ 1.236 =$		$\times 100 =$		+		$+ 1.236 =$
NOZZLE AT POINT	P	Q								
TOTAL REMAINING FACTOR TO WORK WITH	166	166								
MINUS FACTOR LOSS THRU PIPE	24	19								
EQUALS SUB TOTAL FACTOR	142	147								
ELEV. CORRECTION ± .43/FT.	-3	+3								
TOTAL REMAINING FACTOR AT NOZZLE	139	150								
DISCHARGE RATE	12.8	14.8								
ULLAGE CORRECTION FACTOR	.82	.82								
SPECIFIC RATE	10.5	12.1								
FLOW RATE	12.5	1.6								
ORIFICE SIZE	#24	#16								
NOZ. PIPE THD. SIZE	1/2"	3/4"								
PART NUMBER	258742	258741								

MK

PIPE ULLAGE & FACTOR DROPS

Room # A19 & UNDERFLOOR

PIPE SECTION	PIPE SIZE	FLOW RATE	ACTUAL LENGTH X CU. INL PER FOOT	EQUIVALENT PIPE LENGTH X	FACTOR DROP PER EQUIV. FT.	FACTOR DROP	TOTAL DROP AT NOZZLE	QTY. OF NOZZLES
<i>B</i>	<i>2"</i>	<i>14.1</i>	<i>120 x 1 = 120</i>	<i>36' x .076 = 2.74</i>				
<i>B-C</i>	<i>3"</i>	<i>14.1</i>	<i>5 x 88.7 = 266.1</i>	<i>45' x .014 = .63 + 2.74 = 3.37</i>				
<i>C-D</i>	<i>2"</i>	<i>14.1</i>	<i>38 x 40.3 = 1531.1</i>	<i>135' x .076 = 10.26 + 3.37 = 13.63</i>				
<i>O-P</i>	<i>1 1/2"</i>	<i>12.5</i>	<i>22 x 24.4 = 536.8</i>	<i>40' x .251 = 10.04 + 13.63 = 23.67</i>			<i>24 @ P</i>	<i>1</i>
<i>O-Q</i>	<i>3/4"</i>	<i>1.6</i>	<i>31 x 6.41 = 198.7</i>	<i>43' x .125 = 5.37 + 13.63 = 19.0</i>			<i>19 @ Q</i>	<i>1</i>
			<i>2653</i>					

MK



APPLICATION FOR PERMIT

PERMIT ISSUED

B.O.C.A. USE GROUP

B.O.C.A. TYPE OF CONSTRUCTION

ZONING LOCATION PORTLAND, MAINE, Mar. 17. 1977

MAR 21 1977

0129
CITY of PORTLAND

To the DIRECTOR OF BUILDING & INSPECTION SERVICES, PORTLAND, MAINE

The undersigned hereby applies for a permit to erect, alter, repair, demolish, move or install the following building, structure, equipment or change use in accordance with the Laws of the State of Maine, the Portland B.O.C.A. Building Code and Zoning Ordinance of the City of Portland with plans and specifications, if any, submitted herewith and the following specifications:

LOCATION 399 Congress St. Fire District #1 #2

1. Owner's name and address Maine National Bank... same Telephone

2. ~~Owner's~~ Sub: Consumers Fire & Safety-181 Brackett Telephone

3. Contractor's name and address Consolidated Constructors & Bldgs. Telephone 774-2626

4. Architect 616 Congress St. Specifications

Proposed use of building

Last use

Material

Other buildings on same lot

Estimated contractual cost \$..... Fee \$ 15.

FIELD INSPECTOR—Mr. GENERAL DESCRIPTION

This application is for: @ 775-5451 to install a fire extinguishing system

Dwelling Ext. 234 under floor and above ceiling piping, as

Garage per plan (14 nozzles)

Masonry Bldg.

Metal Bldg.

Alterations

Demolitions

Change of Use

Other

Stamp of Special Conditions

NOTE TO APPLICANT: Separate permits are required by the installers and subcontractors of heating, plumbing, electrical and mechanicals.

PERMIT IS TO BE ISSUED TO 1 2 3 4

Other:

DETAILS OF NEW WORK

Is any plumbing involved in this work? Is any electrical work involved in this work?

Is connection to be made to public sewer? If not, what is proposed for sewage?

Has septic tank notice been sent? Form notice sent?

Height average grade to top of plate Height average grade to highest point of roof

Size, front depth No. stories solid or filled land? earth or rock?

Material of foundation Thickness, top bottom cellar

Kind of roof Rise per foot Roof covering

No. of chimneys Material of chimneys of lining Kind of heat fuel

Framing Lumber—Kind Dressed or full size? Corner posts Sills

Size Girder Columns under girders Size Max. on centers

Studs (outside walls and carrying partitions) 2x4-16" O. C. Bridging in every floor and flat roof span over 8 feet.

Joists and rafters: 1st floor, 2nd, 3rd, roof

On centers: 1st floor, 2nd, 3rd, roof

Maximum span: 1st floor, 2nd, 3rd, roof

If one story building with masonry walls, thickness of walls? height?

IF A GARAGE

No. cars now accommodated on same lot, to be accommodated ... number commercial cars to be accommodated ...

Will automobile repairing be done other than minor repairs to cars habitually stored in the proposed building?

APPROVALS BY: DATE

MISCELLANEOUS

BUILDING INSPECTION—PLAN EXAMINER Will work require disturbing of any tree on a public street? ..

ZONING: Will there be in charge of the above work a person competent

BUILDING CODE 3115/10-12-283 - to see that the State and City requirements pertaining thereto

Fire Dept. [Signature] are observed? .. Yes ..

Health Dept.:

Others:

Signature of Applicant [Signature] Phone #

Type Name of above Michael Lydon 1 2 3 4

Other and Address

FIELD INSPECTOR'S COPY

NOTES

5-9-77 work started - *W*
6-21-77 work completed - *W*

Permit No. 77/199
Location 400 Congress St.
Owner Marine National
Date of permit 3-21-77
Approved under permit 3-21-77
Issued for Marine National
Project Abandonment



Main body of the document consisting of two large rectangular sections of horizontal lines, separated by a vertical line, intended for detailed notes or reports.



APPLICATION FOR PERMIT
DEPARTMENT OF BUILDING INSPECTIONS SERVICES
ELECTRICAL INSTALLATIONS

Date March 16, 19 77
 Receipt and Permit number A-00103

To the CHIEF ELECTRICAL INSPECTOR, Portland, Maine:

The undersigned hereby applies for a permit to make electrical installations in accordance with the laws of Maine, the Portland Electrical Ordinance, the National Electrical Code and the following specifications:

LOCATION OF WORK: 400 Congress St
 OWNER'S NAME: Maine Natl. Bank ADDRESS: same

OUTLETS: (number of)

Lights	_____	
Receptacles	_____	FEES
Switches	_____	
Plugmold	_____ (number of feet)	
TOTAL	_____	

FIXTURES: (number of)

Incandescent	_____	
Fluorescent	_____ (Do not include strip fluorescent)	
TOTAL	_____	
Strip Fluorescent, in feet	_____	

SERVICES:

Permanent, total amperes <u>4,000</u>	_____	<u>9.00</u>
Temporary	_____	_____

METERS: (number of) _____

MOTORS: (number of)

Fractional	_____	
1 HP or over	_____	

RESIDENTIAL HEATING:

Oil or Gas (number of units)	_____	
Electric (number of rooms)	_____	

COMMERCIAL OR INDUSTRIAL HEATING:

Oil or Gas (by a main boiler)	_____	
Oil or Gas (by separate units)	_____	
Electric (total number of kws)	_____	

APPLIANCES: (number of)

Ranges	_____	Water Heaters	_____
Cook Tops	_____	Disposals	_____
Wall Ovens	_____	Dishwashers	_____
Dryers	_____	Compactors	_____
Fans	_____	Others (denote)	_____
TOTAL	_____		

MISCELLANEOUS: (number of)

Branch Panels	<u>4</u>	_____	<u>4.00</u>
Transformers	_____		
Air Conditioners	_____		
Signs	_____		
Fire/Burglar Alarms	_____		
Circus, Fairs, e.c.	_____		
Alteration to wires	_____		
Repairs after fire	_____		
Heavy Duty, 220v outlets	_____		
Emergency Lights, battery	_____		
Emergency Generators	_____		

INSTALLATION FEE DUE: 13.00

FOR ADDITIONAL WORK NOT ON ORIGINAL PERMIT DOUBLE FEE DUE:
 FOR REMOVAL OF A "STOP ORDER" (304-16.b)
 FOR PERFORMING WORK WITHOUT A PERMIT (304-9)
TOTAL AMOUNT DUE: 13.00

INSPECTION:
 Will be ready on _____, 19____, or Will Call X

CONTRACTOR'S NAME: Eastern Electric
 ADDRESS: P.O. Box 346
 TEL.: 772-6762

MASTER LICENSE NO.: 3279 SIGNATURE OF CONTRACTOR:
 LIMITED LICENSE NO.: _____

INSPECTOR'S COPY

ELECTRICAL INSTALLATIONS —

Permit Number 0105

Location 5100 CONGRESS ST

Owner MARIE NATIONAL BANK

Date of Permit 3.16.77

Final Inspection 3-22-77

By Inspector R. Kelly

Permit Application Register Page No. 92

INSPECTIONS: Service ✓ by R. Kelly
Service called in 3-22-77
Closing-in _____ by _____

PROGRESS INSPECTIONS:

_____	/	_____	/	_____
_____	/	_____	/	_____
_____	/	_____	/	_____
_____	/	_____	/	_____
_____	/	_____	/	_____
_____	/	_____	/	_____
_____	/	_____	/	_____

**CODE
COMPLIANCE
COMPLETED**
DATE 3-22-77

DATE:	REMARKS:
<u>3-22-77</u>	<u>This has been checked many times before permit was taken because of man on vacation.</u>

[Handwritten signature]

11-30-00



APPLICATION FOR PERMIT

PERMIT ISSUED

B.O.C.A. USE GROUP

B.O.C.A. TYPE OF CONSTRUCTION

FEB 18 1977

ZONING LOCATION PORTLAND, MAINE, Feb. 16, 1977

CITY of PORTLAND

To the DIRECTOR OF BUILDING & INSPECTION SERVICES, PORTLAND, MAINE

The undersigned hereby applies for a permit to erect, alter, repair, demolish, move or install the following building, structure, equipment or change use in accordance with the Laws of the State of Maine, the Portland B.O.C.A. Building Code and Zoning Ordinance of the City of Portland with plans and specifications, if any, submitted herewith and the following specifications:

Send permit to R. Harris- Ne. Natl.

LOCATION, 400 Congress St., 3rd floor. Fire District #1, #2
1 Owner's name and address Maine National Bank Telephone
2 Lessee's name and address Telephone
3 Contractor's name and address Consolidated Constr. & Builders Telephone 774-2626
4 Architect 616 Congress St. Specifications Plans No. of sheets
Proposed use of building bank No. families
Last use bank No. families
Material No. stories Heat Style of roof Roofing
Other buildings on same lot
Estimated contractual cost \$ 30,000 Fee \$ 120.00

FIELD INSPECTOR—Mr. GENERAL DESCRIPTION

This application is for: @ 775-5451
Dwelling Ext. 234 Permit to construct new partitions for computer area on third floor. as per plans. 1 sheet of plans. Stamp of Special Conditions
Garage
Masonry Bldg.
Metal Bldg.
Alterations
Demolitions
Change of Use
Other bank

NOTE TO APPLICANT: Separate permits are required by the installers and subcontractors of heating, plumbing, electrical and mechanicals.

PERMIT IS TO BE ISSUED TO 1 2 3 4

Other:

DETAILS OF NEW WORK

Is any plumbing involved in this work? Is any electrical work involved in this work?
Is connection to be made to public sewer? If not, what is proposed for sewage?
Has septic tank notice been sent? Form notice sent?
Height average grade to top of plate Height average grade to highest point of roof
Size, front depth No. stories solid or filled land? earth or rock?
Material of foundation Thickness, top bottom cellar
Kind of roof Rise per foot Roof covering
No. of chimneys Material of chimneys of lining Kind of heat fuel
Framing Lumber—Kind Dressed or full size? Corner posts Sills
Size Girder Columns under girders Size Max. on centers
Studs (outside walls and carrying partitions) 2x4-16" O. C. Bridging in every floor and flat roof span over 8 feet.
Joists and rafters: 1st floor 2nd 3rd roof
On centers: 1st floor 2nd 3rd roof
Maximum span: 1st floor 2nd 3rd roof
If one story building with masonry walls, thickness of walls? height?

IF A GARAGE

No. cars now accommodated on same lot, to be accommodated number commercial cars to be accommodated
Will automobile repairing be done other than minor repairs to cars habitually stored in the proposed building?

APPROVALS BY: DATE MISCELLANEOUS
BUILDING INSPECTION—PLAN EXAMINER Will work require disturbing of any tree on a public street?
ZONING:
BUILDING CODE: 0:14: E.R. 2/17/77 Will there be in charge of the above work a person competent to see that the State and City requirements pertaining thereto are observed?
Fire Dept.:
Health Dept.:
Others:

Signature of Applicant C.R. Holten Phone # same
Type Name of above C. R. Holten 1 2 3 4

FIELD INSPECTOR'S COPY Other and Address

NOTES

2-18-77 had them come to this permit - *JS*
 2-1-77 has metal Sudding up - *JS*
 3-15-77 still working - *JS*
 5-9-77 still working - *JS*
 6-21-77 Work Completed - *JS*

Permit No. 97/16978
 Location V10 (Campground)
 Owner Mr. M. J. ...
 Date of permit 2-16-77
 Approved 2-18-77 NYS Forest Ranger

[Large handwritten X mark]

[Blank lined area]



APPLICATION FOR PERMIT

B.O.C.A. USE GROUP

B.O.C.A. TYPE OF CONSTRUCTION

ZONING LOCATION _____ PORTLAND, MAINE, Feb. 9, 1977

PERMIT ISSUED

FEB 11 1977

CITY OF PORTLAND

To the DIRECTOR OF BUILDING & INSPECTION SERVICES, PORTLAND, MAINE

The undersigned hereby applies for a permit to erect, alter, repair, demolish, move or install the following building, structure, equipment or change use in accordance with the Laws of the State of Maine, the Portland B.O.C.A. Building Code and Zoning Ordinance of the City of Portland with plans and specifications, if any, submitted herewith and the following specifications:

LOCATION 400 Congress St. Fire District #1 , #2

1. Owner's name and address Maine National Bank same Telephone

2. Lessee's name and address Telephone

3. Contractor's name and address Fels Co. 390 Presumpscot St. Telephone 773-6431

4. Architect Specifications Plans No. of sheets

Proposed use of building bank. No. families

Last use No. families

Material No. stories Heat Style of roof Roofing

Other buildings on same lot

Estimated contractual cost \$ Fee \$.. 20.

FIELD INSPECTOR—Mr. GENERAL DESCRIPTION

This application is for: @ 775-5451 To install air conditioning on third floor
 Dwelling Ext. 234 as per plan - 60 tons
 Garage
 Masonry Bldg. Stamp of Special Conditions
 Metal Bldg.
 Alterations
 Demolitions
 Change of Use
 Other

NOTE TO APPLICANT: Separate permits are required by the installers and subcontractors of heating, plumbing, electrical and mechanicals.

PERMIT IS TO BE ISSUED TO 1 2 3 4

Other:

DETAILS OF NEW WORK

plumbing involved in this work? Is any electrical work involved in this work?

connection to be made to public sewer? If not, what is proposed for sewage?

has septic tank notice been sent? Form notice sent?

height average grade to top of plate Height average grade to highest point of roof

Size, front depth No. stories solid or filled land? earth or rock?

Material of foundation Thickness, top bottom cellar

Kind of roof Rise per foot Roof covering

No. of chimneys Material of chimneys of lining Kind of heat fuel

Framing Lumber—Kind Dressed or full size? Corner posts Sills

Size Girder Columns under girders Size Max. on centers

Studs (outside walls and carrying partitions) 2x4-16" O. C. Bridging in every floor and flat roof span over 8 feet.

Joists and rafters: 1st floor 2nd 3rd roof

On centers: 1st floor 2nd 3rd roof

Maximum span: 1st floor 2nd 3rd roof

If one story building with masonry walls, thickness of walls? height?

IF A GARAGE

No. cars now accommodated on same lot, to be accommodated ... number commercial cars to be accommodated ...

Will automobile repairing be done other than minor repairs to cars habitually stored in the proposed building?

APPROVALS BY:

DATE

MISCELLANEOUS

BUILDING INSPECTION—PLAN EXAMINER Will work require disturbing of any tree on a public street? ..

ZONING:

BUILDING CODE: 4.14.22, 2/9/77 Will there be in charge of the above work a person competent

Fire Dept.: to see that the State and City requirements pertaining thereto

Health Dept.: are observed? ... yes

Others:

Signature of Applicant *Wayne Jones* Phone #

Type Name of above Wayne Jones 1 2 3 4

Other and Address

FIELD INSPECTOR'S COPY

Also Harris 10/11/77

NOTES

2-15-77 started tearing out partitions - will
 come in for permit for partitions - MS
 3-4-77 still working - MS
 3-15-77 Still working - MS
 5-9-77 Air conditioning installed - MS
 6-21-77 All work completed - MS

Permit No. 77/63
 Location 400 Congress St
 Owner Marine National Bank
 Date of permit 2-11-77
 Approved All Conditions on 3rd floor

(The form contains two large columns of horizontal lines, with a large 'X' drawn over the top portion of the left column.)

PERMIT TO INSTALL PLUMBING

Address **400 Congress St.** PERMIT NUMBER **4036**

Installation For **Commercial**

Owner of Bldg **Maine National Bank**

Owner's Address **same**

Plumber **Andrew P. Iverson**

Date **3-10-75**

Date Issued **March 10, 1975**

Portland Plumbing Inspector

By **ERNOLD R GOODWIN**

App. First Insp.

Date

By

App. First Insp.

Date

By

Type of Bldg.

- Commercial
- Residential
- Single
- Multi Family
- New Construction
- Remodeling

NEW	REPL		NO	FEE
1		PO Box 27, Portland		
		SINKS	1	2.00
		LAVATORIES		
		TOILETS		
		BATH TUBS		
		SHOWERS		
		DRAINS FLOOR SURFACE		
		HOT WATER TANKS		
		TANKLESS WATER HEATERS		
		GARBAGE DISPOSALS		
		SEPTIC TANKS		
		HOUSE SEWERS		
		ROOF LEADERS		
		AUTOMATIC WASHERS		
		DISHWASHERS		
		OTHER		
		Buso Fee		3.00
			TOTAL 1	5.00

Building and Inspection Services Dept. Plumbing Inspection

MAR 11 1975
ERNOLD R. GOODWIN
 City of Portland Inspector

CHECK LIST FOR SIGNS

Date - 10/4/73

Checked By M.G.W.

Location - 400 CONGRESS ST.
SIGN LOCATION FEDERAL & EXCHANGE ST.

- Zone Location - B-3
- Fire Zone - 2
- Sign & Review Committee - over 8" in least dimension - NO
- Area of sign - 60"
- Area of existing signs -
- Material -
- Design -
- Facing adjoining Residence Zone - NO
- Flashing or Steady light -
- If on State road - check with State -

Attached Sign -

- Height above level of roof - 9'

Detached or pole sign -

- Height -
- Required yards (single pole OK - 2 poles a structure) 40"
- setback
- Corner clearance -
- Footing -
- Certificate of Design -

Projecting Sign -

- Clearance 10' -
- Bonded -
- Height -
- Written Consent -
- Projection over sidewalk (18" from curb) -



B3 BUSINESS ZONE

APPLICATION FOR PERMIT

Class of Building or Type of Structure Bank _____ 01158

Portland, Maine, Oct 3, 1973

PERMIT ISSUED

OCT 5 1973

CITY OF PORTLAND

To the INSPECTOR OF BUILDINGS, PORTLAND, MAINE

The undersigned hereby applies for a permit to erect alter repair demolish install the following building structure equipment in accordance with the Laws of the State of Maine, the Building Code and Zoning Ordinance of the City of Portland, plans and specifications, if any, submitted herewith and the following specifications:

Location 400 Congress St Within Fire Limits? _____ Dist. No. _____
Owner's name and address Maine National Bank, same Telephone _____
Lessee's name and address _____ Telephone _____
Contractor's name and address Coyne Sign Co. Telephone _____
Architect _____ Specifications _____ Plans _____ No. of sheets _____
Proposed use of building _____ No. families _____
Last use _____ No. families _____
Material _____ No. stories _____ Heat _____ Style of roof _____ Roofing _____
Other buildings on same lot _____
Estimated cost \$ _____ Fee \$ 11.00

General Description of New Work

Erect a 15' x 4' double faced sign on roof of ~~xxx~~ drive-in as per plan.

It is understood that this permit does not include installation of heating apparatus which is to be taken out separately by and in the name of the heating contractor. PERMIT TO BE ISSUED TO

Details of New Work

Is any plumbing involved in this work? _____ Is any electrical work involved in this work? _____
Is connection to be made to public sewer? _____ If not, what is proposed for sewage? _____
Has septic tank notice been sent? _____ Form notice sent? _____
Height average grade to top of plate _____ Height average grade to highest point of roof _____
Size, front _____ depth _____ No. stories _____ solid or filled land? _____ earth or rock? _____
Material of foundation _____ Thickness, top _____ bottom _____ cellar _____
Kind of roof _____ Rise per foot _____ Roof covering _____
No. of chimneys _____ Material of chimneys _____ of lining _____ Kind of heat _____ fuel _____
Framing Lumber-Kind _____ Dressed or full size? _____ Corner posts _____ Sills _____
Size Girder _____ Columns under girders _____ Size _____ Max. on centers _____
Studs (outside walls and carrying partitions) 2x4-16" O. C. Bridging in every floor and flat roof span over 8 feet.
Joists and rafters: 1st floor _____, 2nd _____, 3rd _____, roof _____
On centers: 1st floor _____, 2nd _____, 3rd _____, roof _____
Maximum span: 1st floor _____, 2nd _____, 3rd _____, roof _____
If one story building with masonry walls, thickness of walls? _____ height? _____

Is a Garage

No. cars now accommodated on same lot _____, to be accommodated _____ number commercial cars to be accommodated _____
Will automobile repairing be done other than minor repairs to cars habitually stored in the proposed building? _____

APPROVED:

10/4/73 ZONING OK M.C.W.
10/4/73 - O.K. C.P.

Miscellaneous

Will work require disturbing of any tree on a public street? _____
Will there be in charge of the above work a person competent to see that the State and City requirements pertaining thereto are observed? YES

CS 301

INSPECTION COPY

Signature of owner by:

[Handwritten signature]

Permit No. 73/1158

Nelson

Location 400 Congress St

Owner Main State Bank

Date of permit 10/5/73

Notif. closing-in

Inspn. closing in

Final Notif.

Final Inspn.

Cert. of Occupancy issued

Staking Out Notice

Form Check Notice

NOTES

400 Congress Street

June 5, 1973

Maine National Bank
400 Congress Street

Gentlemen:

Wherever masonry units are being tied together it is necessary that No. 6 wire ties be used either 2 or Drip and they are to be spaced no more than 16" vertically and 2' horizontally.

Exit signs are to be provided over the north exit door as well as a white light outside that exit door, preferably operating on the same switch as the exit sign.

Very truly yours,

Earle S. Smith
Plan Examiner

ESS:m

400 CONG. ST.

TALLEY BLDG.

5/25/93 11:00

CHECK LIST AGAINST ZONING ORDINANCE

- ✓ Date - EXISTING
- ✓ Zone Location - B-3
- ✓ Interior or corner lot -
- ✓ 40 ft. setback area (Section 2) - NO
- ✓ Use - BANK & PARKING DRIVE UP TALLEY W/DRIVE
- ✓ Sewage Disposal - PUBLIC
- ✓ Rear Yards - NOT REQ.
- ✓ Side Yards - " "
- ✓ Front Yards - " "
- ✓ Projections - NONE
- ✓ Height - 1 STORY
- ~~Lot Area -~~
- ~~Building Area -~~
- ~~Area per Family -~~
- ~~Width of Lot -~~
- ~~Lot Frontage -~~
- ✓ Off-street Parking - NONE REQ.
- ✓ Loading bays - 1 BAY REQ. 400 S TW 1

5/25/93 planning Board O.K.

ADDRESS 400 Congress St
Mr Matenall Barly
5/24/73

ROUTING SLIP
FROM

DEPARTMENT OF BUILDING AND INSPECTION SERVICES

- FIRE DEPARTMENT
- PLANNING BOARD
- RENEWAL
- MAINE WAY
- OTHERS

APPROVED *C. O. Ouellet*

DISAPPROVED BY REASON OF

(quote section of pertinent ordinance or other governing factors)

SPECIAL COMMENTS _____

KEEP SECOND COPY AND RETURN ORIGINAL TO BUILDING AND INSPECTION SERVICES



B2 BUSINESS ZONE

APPLICATION FOR PERMIT

Class of Building or Type of Structure _____

Portland, Maine, May 24, 1973

PERMIT ISSUED

JUN 5 1973

00602

CITY OF PORTLAND

To the INSPECTOR OF BUILDINGS, PORTLAND, MAINE

The undersigned hereby applies for a permit to erect alter repair demolish install the following building structure equipment in accordance with the Laws of the State of Maine, the Building Code and Zoning Ordinance of the City of Portland Maine and specifications, if any, submitted herewith and the following specifications:

Location 400 Congress St. Within Fire Line _____ No. _____
 Owner's name and address Maine National Bank, same _____
 Lessee's name and address _____
 Contractor's name and address Unknown _____
 Architect _____ Specifications yes Plans yes _____
 Proposed use of building bank & offices No. family _____
 Last use 2 " _____ No. family _____
 Material _____ No. stories _____ Heat _____ Style of roof _____ Roofing _____
 Other buildings on same lot _____
 Estimated cost \$ 300,000. Fee \$ 90.

General Description of New Work

To create a pedestrian plaza, parking area and new entrance to bank
New service entrance, new drive-ins - as per plans

PERMIT ISSUED WITH LETTER

5/30/73
6/14/73
Sent to fire dept
Back from fire dept

It is understood that this permit does not include installation of heating apparatus which is to be installed separately by _____ the name of the heating contractor. **PERMIT TO BE ISSUED TO** _____

owner _____
Maine National Bank

Details of New Work:

Is any plumbing involved in this work? _____ Is any electrical work involved in this work? _____
 Is connection to be made to public sewer? _____ If not, what is proposed for sewage? _____
 Has septic tank notice been sent? _____ Form notice sent? _____
 Height average grade to top of plate _____ Height average grade to highest point of roof _____
 Size, front _____ depth _____ No. stories _____ solid or filled land? _____ earth or rock? _____
 Material of foundation _____ Thickness, top _____ bottom _____ cellar _____
 Kind of roof _____ Rise per foot _____ Roof covering _____
 No. of chimneys _____ Material of chimneys _____ of lining _____ Kind of heat _____ fuel _____
 Framing Lumber—Kind _____ Dressed or full size? _____ Corner posts _____ Sills _____
 Size Girder _____ Columns under girders _____ Size _____ Max on centers _____
 Studs (outside walls and carrying partitions) 2x4-16" O. C. Bridging in every floor and flat roof span over 8 feet.
 Joists and rafters: 1st floor _____, 2nd _____, 3rd _____, roof _____
 On centers: 1st floor _____, 2nd _____, 3rd _____, roof _____
 Maximum span: 1st floor _____, 2nd _____, 3rd _____, roof _____
 If one story building with masonry walls, thickness of walls? _____ height? _____

If a Garage

No. cars now accommodated on same lot _____, to be accommodated _____ number commercial cars to be accommodated _____
Will automobile repairing be done other than minor repairs to cars habitually stored in the proposed building? _____

APPROVED:

5/25/73 Review ok new
6/14/73 Line C. O. O'Neil
o.k. E.B. 6/5/73

Miscellaneous

Will work require disturbing of any tree on a public street? _____
Will there be in charge of the above work a person competent to see that the State and City requirements pertaining thereto are observed? yes

Maine National Bank

CS 301

INSPECTION COPY

Signature of owner by: _____

BOCA
CODE CHECK WITH
PORTLAND AMENDMENTS

P.R.

[Signature]
Vice. Pres.

NOTES

6-13-73 Bob Harris to
check with arch. on
wall tying. May
change stair exit to
less expensive material

PH

12-12-73 Masonary
work done - PH

4-22-74

Completed

PH

H/L

Permit No. 73/602
 Location 400 Congress St
 Owner Mare National Bank
 Date of permit 6/5/73
 Notif. closing-in
 Inspn. closing-in
 Final Notif.
 Final Inspn.
 Cert. of Occupancy issued
 Staking Out Notice
 Form Check Notice

ADDRESS 400 Congress St

3/29/73

Maine Nat. Bank

ROUTING SLIP

FROM

DEPARTMENT OF BUILDING AND INSPECTION SERVICES

FIRE DEPARTMENT

PLANNING BOARD

RENEWAL

MAINE WAY

OTHERS

APPROVED Ronald E. Magallan Jr. (APR)

DISAPPROVED BY REASON OF

(quote section of pertinent ordinance or other governing factors)

SPECIAL COMMENTS _____

KEEP SECOND COPY AND RETURN ORIGINAL TO BUILDING AND INSPECTION SERVICES

FILE



APPLICATION FOR AMENDMENT TO PERMIT

PERMIT ISSUED

Amendment No. #1

JAN 13 1972

Portland, Maine, Jan. 10, 1972

CITY OF PORTLAND

To the INSPECTOR OF BUILDINGS, PORTLAND, MAINE

The undersigned hereby applies for amendment to Permit No. 71/1319 pertaining to the building or structure comprised in the original application in accordance with the Laws of the State of Maine, the Building Code and Zoning Ordinance of the City of Portland, plans and specifications, if any, submitted herewith, and the following specifications:

Location . 396 Congress Street Within Fire Limits? Dist. No.

Owner's name and address Maine National Bank, 396 Congress St. Telephone

Lessee's name and address Telephone

Contractor's name and address Consolidated Constructors & Builders, Telephone 773-5256
615 Congress St.

Architect Plans filed yes No. of sheets 2

Proposed use of building Bank of a offices No. families

Last use " No. families

Increased cost of work 30,000 Additional fee 90.00

Description of Proposed Work

To make alteration to first floor as per plans

Completed / 4/10/72

Details of New Work Contractor

Is any plumbing involved in this work? Is any electrical work involved in this work?

Height average grade to top of plate Height average grade to highest point of roof

Size, front depth No. stories solid or filled land? earth or rock?

Material of foundation Thickness, top bottom cellar

Material of underpinning Height Thickness

Kind of roof Rise per foot Roof covering

No. of chimneys Material of chimneys of lining

Framing lumber—Kind Dressed or full size

Corner posts Sills Girt or ledger board? Size

Girders Size Columns under girders Size Max. on centers

Studs (outside walls and carrying partitions) 2x4-16" O. C. Bridging in every floor and flat roof span over 8 feet.

Joists and rafters: 1st floor 2nd 3rd roof

On centers: 1st floor 2nd 3rd roof

Maximum span: 1st floor 2nd 3rd roof

Approved: *O.R. N.F.C. 1/12/72*

Maine National Bank
Consolidated Constructors & Builders
Signature of Owner *[Signature]*
By: *[Signature]*
Approved: *[Signature]*
Inspector of Buildings

INSPECTION COPY
CS. 105

396 Congress Street

Oct. 26, 1971

Maine National Bank
396 Congress Street

cc to: Consolidated Constructors
& Builders, 616 Congress St.

Gentlemen:

Building permit to make alterations on the fifth and sixth floors of this building at the above named location is issued subject to Building Code requirements as follows:

1. Door No. 603 to go to office 603 cannot be equipped with any locking devices. This door must be so that anyone at all times may open this and go to the window that opens on to the fire escape for this floor.
2. Exit sign or lights as per Section 602.5.5 of the Code must be provided over this door 603 and over the window opening on to the fire escape from this office area, with white light outside.
3. Kitchen area on the fifth floor, Room 505, as well as, cooking facilities in 506 must have the approval of the Health Department before they are installed.
4. The toilet rooms on the sixth floor must be vented as required by the Plumbing Inspector. Open aisles as shown on the plans for the cafeteria area on the fifth floor must be maintained to all exit ways.

Very truly yours,

A. Allan Soule
Assistant Director

AAS:m

PERMIT ISSUED

OCT 26 1971

CITY of PORTLAND



APPLICATION FOR PERMIT

Class of Building or Type of Structure

Portland, Maine, October 7, 1971

To the INSPECTOR OF BUILDINGS, PORTLAND, MAINE

The undersigned hereby applies for a permit to erect alter repair demolish install the following building structure equipment in accordance with the Laws of the State of Maine, the Building Code and Zoning Ordinance of the City of Portland, plans and specifications, if any, submitted herewith and the following specifications:

Location 396 Congress St. Within Fire Limits? Dist. No. Owner's name and address Maine National Bank, 396 Congress St. Telephone Lessee's name and address Contractor's name and address Consolidated Constructors & Builders 616 Congress Telephone 773-5256 Architect Specifications Plans Yes No. of sheets 22 Proposed use of building Bank No. families Last use No. families Material No. stories Heat Style of roof Roofing Other buildings on same lot Estimated cost \$ 50,000 Fee \$ 150.00

General Description of New Work

(Alterations to 5th and 6th floors) To make alterations to 5th/floors as per plan.

803/240 240/150 150/90

Sent to Fire Dept 10/15/71 Rec'd from Fire Dept 10/20/71

It is understood that this permit does not include installation of heating apparatus which is to be taken out separately by and in the name of the heating contractor. PERMIT TO BE ISSUED TO

Owner

Details of New Work

Is any plumbing involved in this work? Is any electrical work involved in this work? Is connection to be made to public sewer? If not, what is proposed for sewage? Has septic tank notice been sent? Form notice sent? Height average grade to top of plate Height average grade to highest point of roof Size, front depth No. stories solid or filled land? earth or rock? Material of foundation Thickness, top bottom cellar Kind of roof Rise per foot Roof covering No. of chimneys Material of chimneys of lining Kind of heat fuel Framing Lumber-Kind Dressed or full size? Corner posts Sills Size Girder Columns under girders Size Max. on centers Studs (outside walls and carrying partitions) 2x4-16" O. C. Bridging in every floor and flat roof span over 8 feet Joists and rafters: 1st floor, 2nd, 3rd, roof On centers: 1st floor, 2nd, 3rd, roof Maximum span: 1st floor, 2nd, 3rd, roof If one story building with masonry walls, thickness of walls? height?

If a Garage

No. cars now accommodated on same lot, to be accommodated number commercial cars to be accommodated Will automobile repairing be done other than minor repairs to cars habitually stored in the proposed building?

Miscellaneous

Will work require disturbing of any tree on a public street? Will there be in charge of the above work a person competent to see that the State and City requirements pertaining thereto are observed? yes

APPROVED:

J.R. Burns - 7 mi - 10-20-71 G.H. - 10/26/71 - Allen w/ ltr

PERMIT ISSUED WITH LETTER

INSPECTION COPY Signature of owner By:

Consolidated Constructors & Builders

Alexander H. Currier

NOTES

11-2-71 Closing in (10)
2-2-72 Completed
except Exit
lights rear office
of Bob Harris (10)
2-22-72
Completed (10)

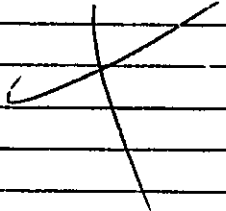

Permit No. 71/ 1319
Location 396 Congress St
Owner Maine National Bank
Date of permit 10/26/71
Notif. closing-in
Inspn. closing-in
Final Notif.
Final Inspn.
Cert. of Occupancy issued
Staking Out Notice
Form Check Notice