

City of Portland, Maine - Building or Use Permit Application

389 Congress Street, 04101 Tel: (207) 874-8703, Fax: (207) 874-8716

Permit No: 04-1664	Issue Date: NOV 17 2004	GBL: 418A A002001
-----------------------	----------------------------	----------------------

Location of Construction: 474 Presumpscot St	Owner Name: Devito Vincent G Wwii Vet &	Owner Address: 474 Presumpscot St	Phone:
Business Name:	Contractor Name: Owner	Contractor Address: Portland	Phone:
Lessee/Buyer's Name	Phone:	Permit Type: Sheds	Zone: R3

Past Use: Single Family Home	Proposed Use: Single Family Home / Install 220 Sq ft Shed	Permit Fee: \$39.00	Cost of Work: \$2,000.00	CEO District: 4
Proposed Project Description: Install 220 Sq ft Shed		FIRE DEPT: <input type="checkbox"/> Approved <input type="checkbox"/> Denied	INSPECTION: Use Group: R3 Type: accessory IRC 2003	

Signature:	Signature: JMB 11/16/04
PEDESTRIAN ACTIVITIES DISTRICT (P.A.D.)	
Action: <input type="checkbox"/> Approved <input type="checkbox"/> Approved w/Conditions <input type="checkbox"/> Denied	
Signature:	Date:

Permit Taken By: Idobson	Date Applied For: 11/05/2004	Zoning Approval
-----------------------------	---------------------------------	------------------------

<p>1. This permit application does not preclude the Applicant(s) from meeting applicable State and Federal Rules.</p> <p>2. Building permits do not include plumbing, septic or electrical work.</p> <p>3. Building permits are void if work is not started within six (6) months of the date of issuance. False information may invalidate a building permit and stop all work..</p>	Special Zone or Reviews <input type="checkbox"/> Shoreland <input type="checkbox"/> Wetland <input type="checkbox"/> Flood Zone <input type="checkbox"/> Subdivision <i>OK</i> <input type="checkbox"/> Site Plan Maj <input type="checkbox"/> Minor <input type="checkbox"/> MM <input type="checkbox"/> Date: <i>JMB 11/16/04</i>	Zoning Appeal <input type="checkbox"/> Variance <input type="checkbox"/> Miscellaneous <input type="checkbox"/> Conditional Use <input type="checkbox"/> Interpretation <input type="checkbox"/> Approved <input type="checkbox"/> Denied Date:	Historic Preservation <input checked="" type="checkbox"/> Not in District or Landmark <input type="checkbox"/> Does Not Require Review <input type="checkbox"/> Requires Review <input type="checkbox"/> Approved <input type="checkbox"/> Approved w/Conditions <input type="checkbox"/> Denied Date: <i>JMB</i>
---	---	---	---

CERTIFICATION

I hereby certify that I am the owner of record of the named property, or that the proposed work is authorized by the owner of record and that I have been authorized by the owner to make this application as his authorized agent and I agree to conform to all applicable laws of this jurisdiction. In addition, if a permit for work described in the application is issued, I certify that the code official's authorized representative shall have the authority to enter all areas covered by such permit at any reasonable hour to enforce the provision of the code(s) applicable to such permit.

SIGNATURE OF APPLICANT _____ ADDRESS _____ DATE _____ PHONE _____

RESPONSIBLE PERSON IN CHARGE OF WORK, TITLE _____ DATE _____ PHONE _____

DISPLAY THIS CARD ON PRINCIPAL FRONTAGE OF WORK

CITY OF PORTLAND

BUILDING INSPECTION

PERMIT

Permit Number: 041664

PERMIT ISSUED

NOV 17 2004

CITY OF PORTLAND

Please Read Application And Notes, If Any, Attached

This is to certify that Devito Vincent G Wvii Vet Owner

has permission to Install 220 sq ft Shed

AT 474 Presumpscot St

418A A002001

provided that the person or persons, firm or corporation accepting this permit shall comply with all of the provisions of the Statutes of Maine and of the ordinances of the City of Portland regulating the construction, maintenance and use of buildings and structures, and of the application on file in this department.

Apply to Public Works for street line and grade if nature of work requires such information.

Notification of inspection must be given and when permission procured before this building or part thereof is occupied or closed-in. 48 HOUR NOTICE IS REQUIRED.

A certificate of occupancy must be procured by owner before this building or part thereof is occupied.

OTHER REQUIRED APPROVALS

Fire Dept.

Health Dept.

Appeal Board

Other

Department Name

Jamie Bank 11/16/04 Director - Building & Inspection Services

PENALTY FOR REMOVING THIS CARD

All Purpose Building Permit Application

If you or the property owner owes real estate or personal property taxes or user charges on any property within the City, payment arrangements must be made before permits of any kind are accepted.

Location/Address of Construction: <u>474 Presumpscot ST Portland ME 04105</u>		
Total Square Footage of Proposed Structure <u>220 sq ft</u>	Square Footage of Lot <u>6 acres</u>	
Tax Assessor's Chart, Block & Lot Chart# Block# Lot# <u>418A - A - 002</u>	Owner: <u>Vincent/Ethel DeB. Jr</u>	Telephone: <u>772-2716</u>
Lessee/Buyer's Name (If Applicable)	Applicant name, address & telephone: <u>Anita DeVito 474 Presumpscot ST</u>	Cost Of Work: \$ <u>2000.00</u> Fee: \$ <u>39.00</u>
Current use: <u>lawn</u> <u>7722716</u>		
If the location is currently vacant, what was prior use: _____		
Approximately how long has it been vacant: _____		
Proposed use: <u>shed</u>		
Project description: _____		
Contractor's name, address & telephone: _____		
Who should we contact when the permit is ready: <u>Anita DeVito</u>		
Mailing address: <u>474 Presumpscot ST Portland ME 04105</u>		
We will contact you by phone when the permit is ready. You must come in and pick up the permit and review the requirements before starting any work, with a Plan Reviewer. A stop work order will be issued and a \$100.00 fee if any work starts before the permit is picked up. PHONE: <u>772-2716</u>		

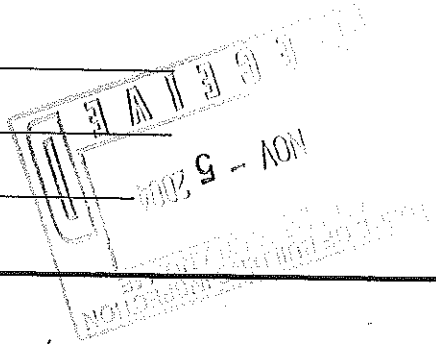

IF THE REQUIRED INFORMATION IS NOT INCLUDED IN THE SUBMISSIONS THE PERMIT WILL BE AUTOMATICALLY DENIED AT THE DISCRETION OF THE BUILDING/PLANNING DEPARTMENT, WE MAY REQUIRE ADDITIONAL INFORMATION IN ORDER TO APPROVE THIS PERMIT.

I hereby certify that I am the Owner of record of the named property, or that the owner of record authorizes the proposed work and that I have been authorized by the owner to make this application as his/her authorized agent. I agree to conform to all applicable laws of this jurisdiction. In addition, if a permit for work described in this application is issued, I certify that the Code Official's authorized representative shall have the authority to enter all areas covered by this permit at any reasonable hour to enforce the provisions of the codes applicable to this permit.

Signature of applicant: <u>Anita DeVito</u>	Date: <u>11/4/04</u>
---	----------------------

This is NOT a permit, you may not commence ANY work until the permit is issued. If you are in a Historic District you may be subject to additional permitting and fees with the Planning Department on the 4th floor of City Hall

This page contains a detailed description of the Parcel ID you selected. Press the **New Search** button at the bottom of the screen to submit a new query.

Current Owner Information

Card Number 1 of 1
 Parcel ID 418A A002001
 Location 474 PRESUMPSCOT ST
 Land Use SINGLE FAMILY

Owner Address DEVITO VINCENT G WWII VET & ETHEL H JTS
 474 PRESUMPSCOT ST
 PORTLAND ME 04103

Book/Page
 Legal 418A-A-2
 PRESUMPSCOT ST 448-488
 OCEAN AVE 921-979
 165450 SF

R3

Valuation Information

Land	Building	Total
\$55,130	\$82,110	\$137,240

Property Information

Year Built 1947	Style Old Style	Story Height 2	Sq. Ft. 1872	Total Acres 3.798		
Bedrooms 3	Full Baths 1	Half Baths 1	Total Rooms 7	Attic None	Basement Full	

Outbuildings

Type	Quantity	Year Built	Size	Grade	Condition
------	----------	------------	------	-------	-----------

Sales Information

Date	Type	Price	Book/Page
------	------	-------	-----------

Picture and Sketch

[Picture](#) [Sketch](#) [Tax Map](#)

[Click here to view Tax Roll Information.](#)

Any information concerning tax payments should be directed to the Treasury office at 874-8490 or e-mailed.

New Search!

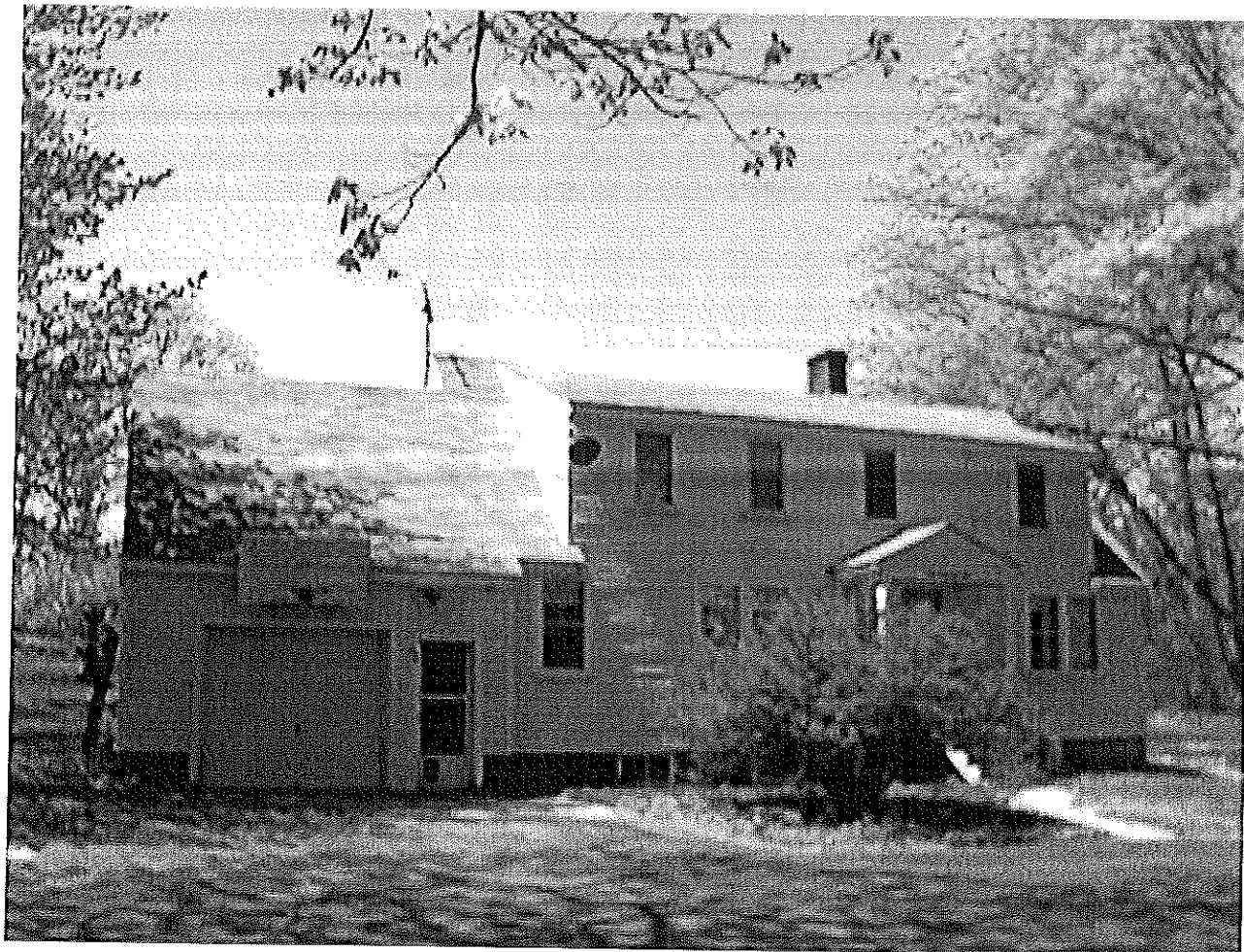

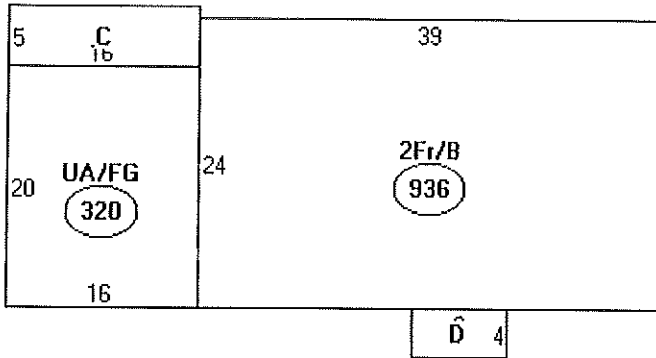

Descriptor/Area

A: 2Fr/B
936 sqft

B: UA/FG
320 sqft

C: EP
80 sqft

D: OFP
32 sqft

Lot = 165,450
Coverage ok

Know all Men by these Presents,

That I, Vincent George DeVito, of the City of Portland, County of Cumberland and State of Maine,

in consideration of One Dollar and other valuable considerations

paid by Vincent G. DeVito and Ethel H. DeVito, both

whose mailing address is 474 Presumpscot Street, Portland, Maine 04103

the receipt whereof I do hereby acknowledge, do hereby give, grant, bargain, sell and convey unto the said Vincent G. DeVito and Ethel H. DeVito, as joint tenants and not as tenants in common,

their heirs and assigns forever,

A certain lot or parcel of land with the buildings thereon, situated in that part of Portland formerly Deering on the westerly side of Presumpscot Street, formerly known as Falmouth Road, on Rocky Hill, so-called, bounded and described as follows: Beginning at a monument and running northerly two hundred (200) feet by the side of said Presumpscot Street, formerly Falmouth Road, to a monument; thence westerly one hundred fifty (150) feet to a monument; thence southerly two hundred (200) feet to a monument; thence easterly one hundred fifty (150) feet to starting point.

Also another lot or parcel of land with the buildings thereon, situated on the aforesaid Rocky Hill adjoining the Graves lot on the westerly side of said Presumpscot Street, formerly called Falmouth Road, called the Heater Place, bounded as follows: Beginning at the aforesaid Graves lot and running southerly by the said Presumpscot Street, formerly called Falmouth Road, two hundred fifty-five (255) feet to a monument; thence westerly two hundred eighty-seven (287) feet to a monument; thence northerly three hundred twenty-three (323) feet to said Graves line; thence along the said Graves line easterly one hundred forty (140) feet to starting point. Being the same premises conveyed to Cornelius Driscoll by Frederick Storer by Warranty Deed dated October 7, 1884, and recorded in Cumberland County Registry of Deeds, Book 512, Page 69.

Also a certain lot or parcel of land with the buildings thereon, situated in that part of Portland formerly Deering at Rocky Hill, so-called, and being a part of the lot conveyed to Frederick Storer by Orlando Leighton by deed dated April 21, 1874, and recorded in Cumberland County Registry of Deeds, Book 410, Page 317, on the westerly side of the road running to Falmouth and being all the lands on the westerly side of the road (Presumpscot Street) conveyed to Frederick Storer by said Orlando Leighton, excepting a lot conveyed to Angie Sweet by deed dated September 22, 1884, and recorded in Cumberland County Registry of Deeds, Book 512, Page 1, southerly corner adjoining James Knowles and also lot conveyed to Cornelius Driscoll by deed dated October 7, 1884, and recorded in Cumberland County Registry of Deeds, Book 512, Page 69, northerly and adjoining Graves lot, so-called. Said lot containing five (5) acres, more or less, being all of the land owned by Catherine F. Driscoll on Rocky Hill, so-called, on the westerly side of the road (Presumpscot Street) leading to Falmouth, Maine.

60

Excepting and reserving therefrom a certain lot or parcel of land with the buildings thereon as was conveyed by the Danish Park Association to Monola B. Rosenbloom by deed dated May 22, 1924, and recorded in Cumberland County Registry of Deeds, Book 1171, Page 66, and deed of Danish Park Association to Armstrong Realty Corporation dated August 31, 1925, and recorded in Cumberland County Registry of Deeds, Book 1210, Page 400.

Meaning and intending to convey part of the premises conveyed to Danish Park Association by Hans E. Hansen, Anders N. Bruns, Jeppe A. Boe, Karl W. Furst, Trustee, by deed dated March 15, 1921, and recorded in Cumberland County Registry of Deeds, Book 1071, Page 362.

No 418A

R3 Zone
25' Front
25' Rear
8' Sides

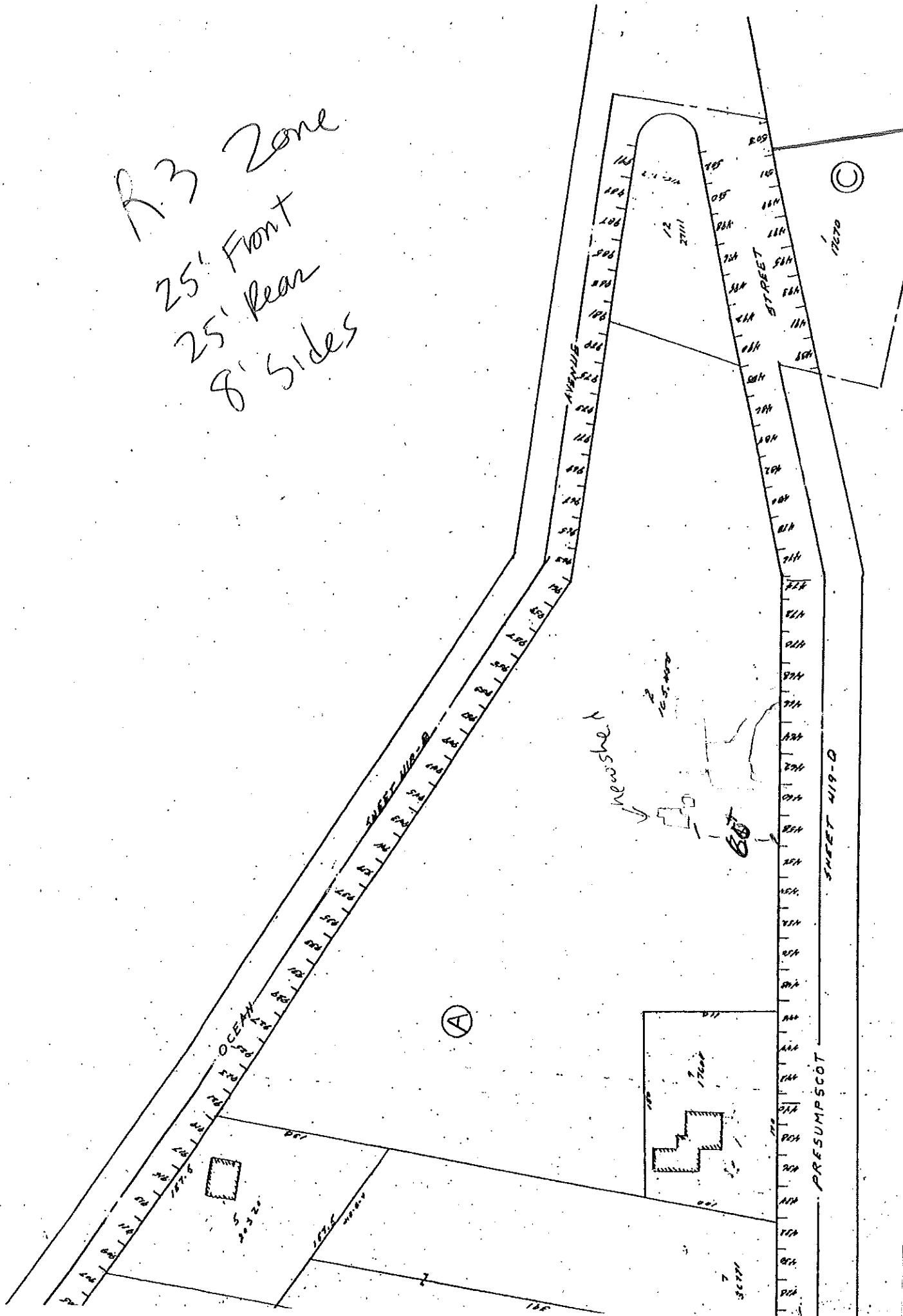

next house

100'

100'

50'

NO. 2301TR20 20X20 PER INCH

WTELEDYNE
NATIONAL TRACING PAPER
INDIANAPOLIS, INDIANA

proceeding south

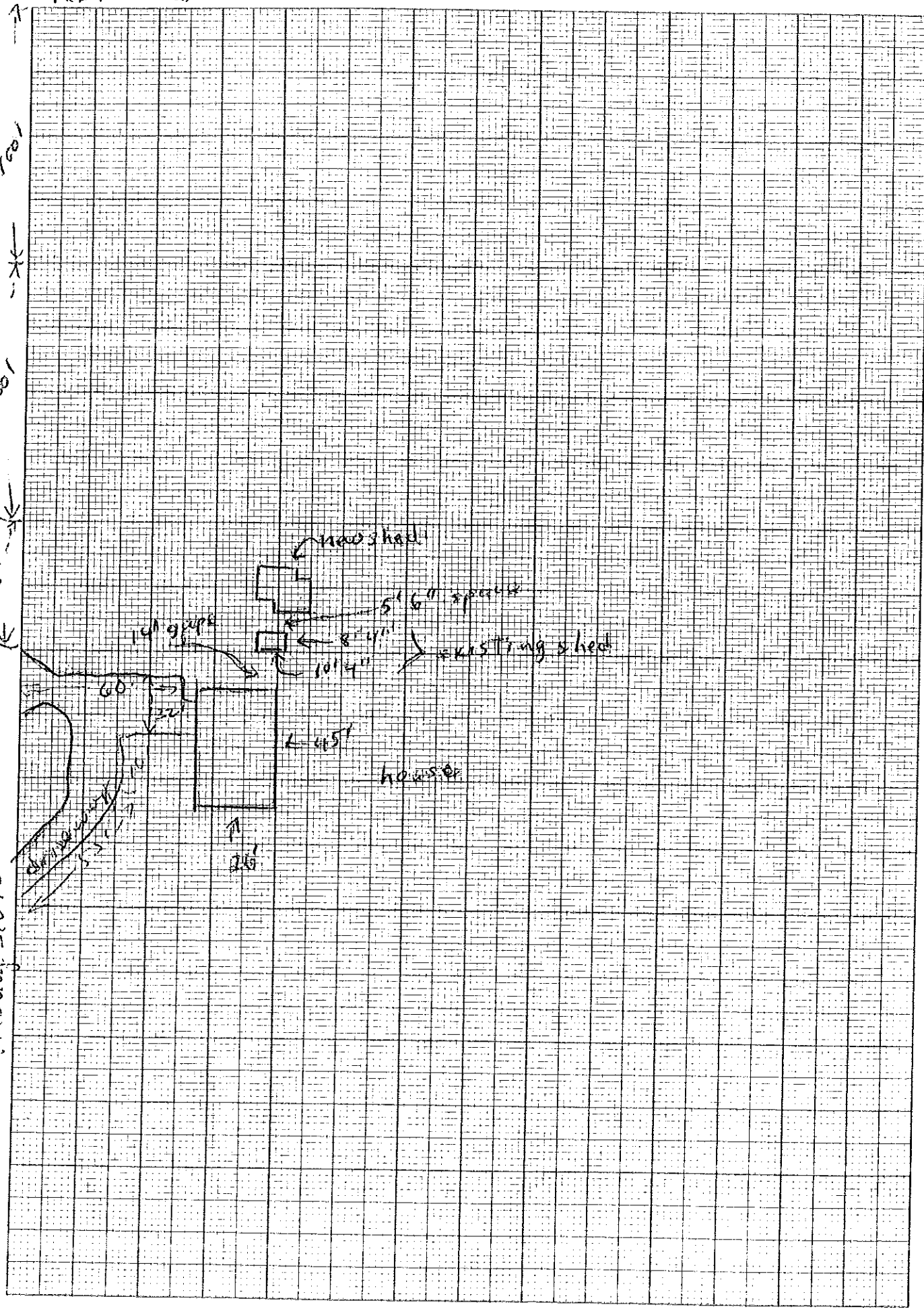

DIMENSION
PLAN

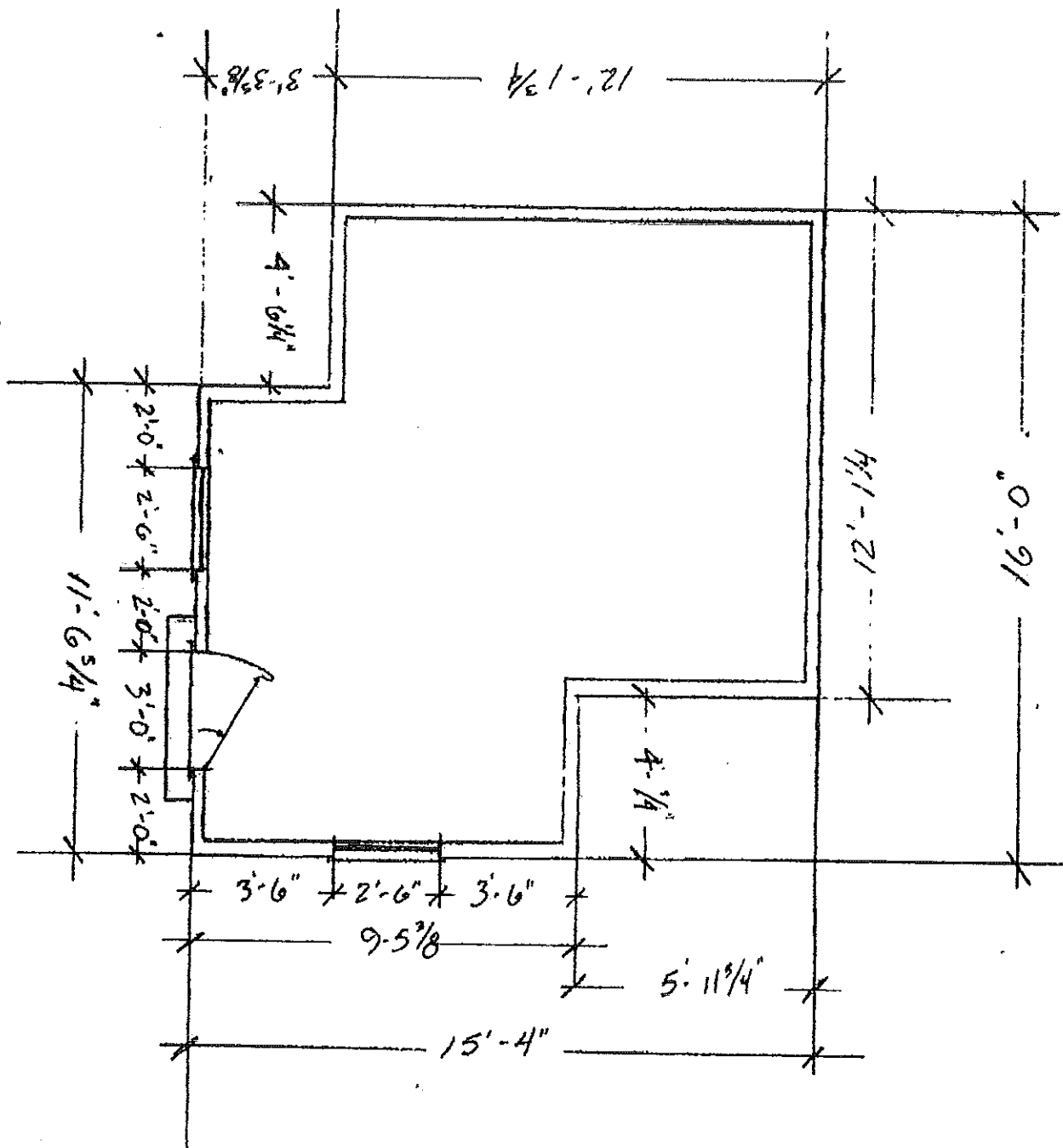

FLOOR PLAN

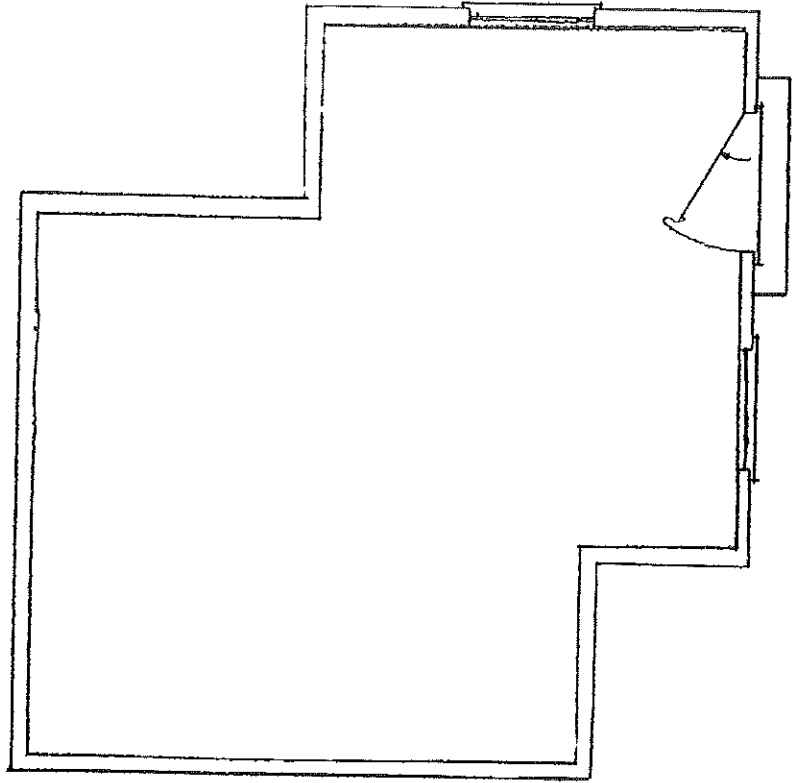

FLOOR FRAME.

2x8 16" O.C.

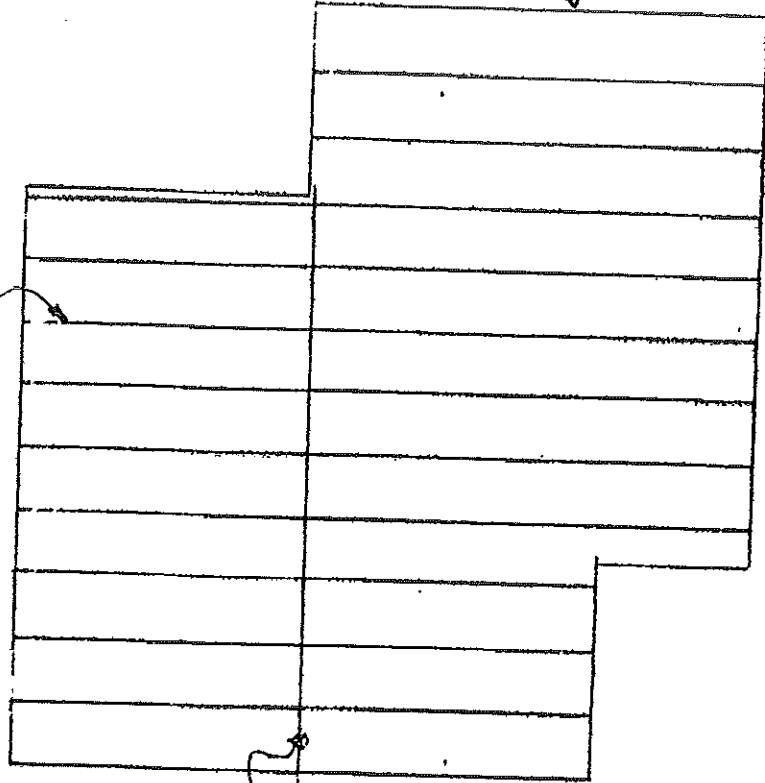

3-2x8
BEAM

2x8 RIM
JOISTS



Foundation
Cement block
out line

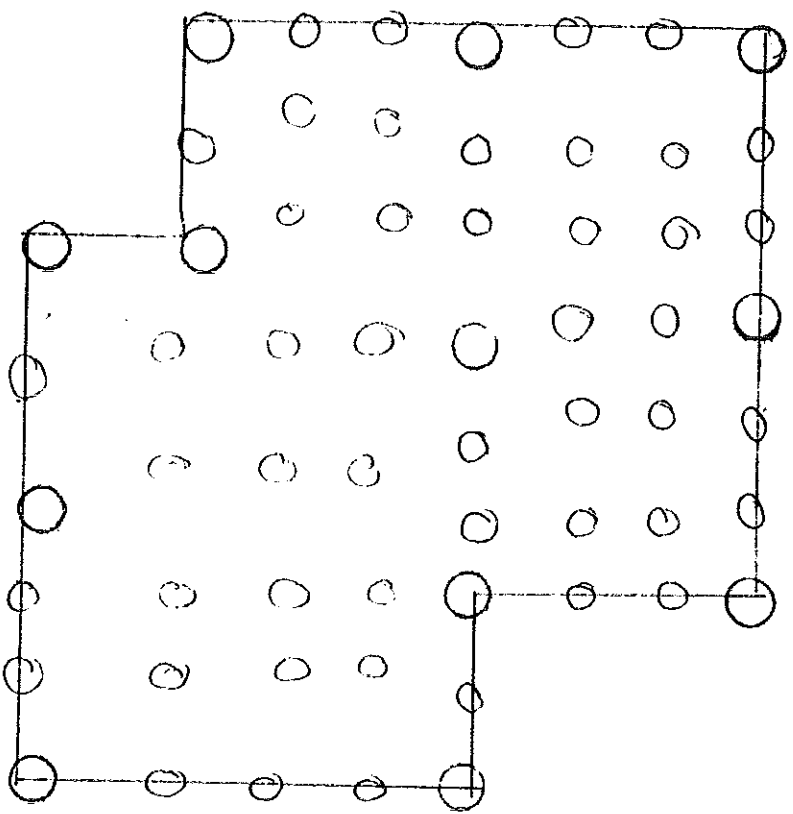

WALL SECTION 1

3/8" = 1'-0"

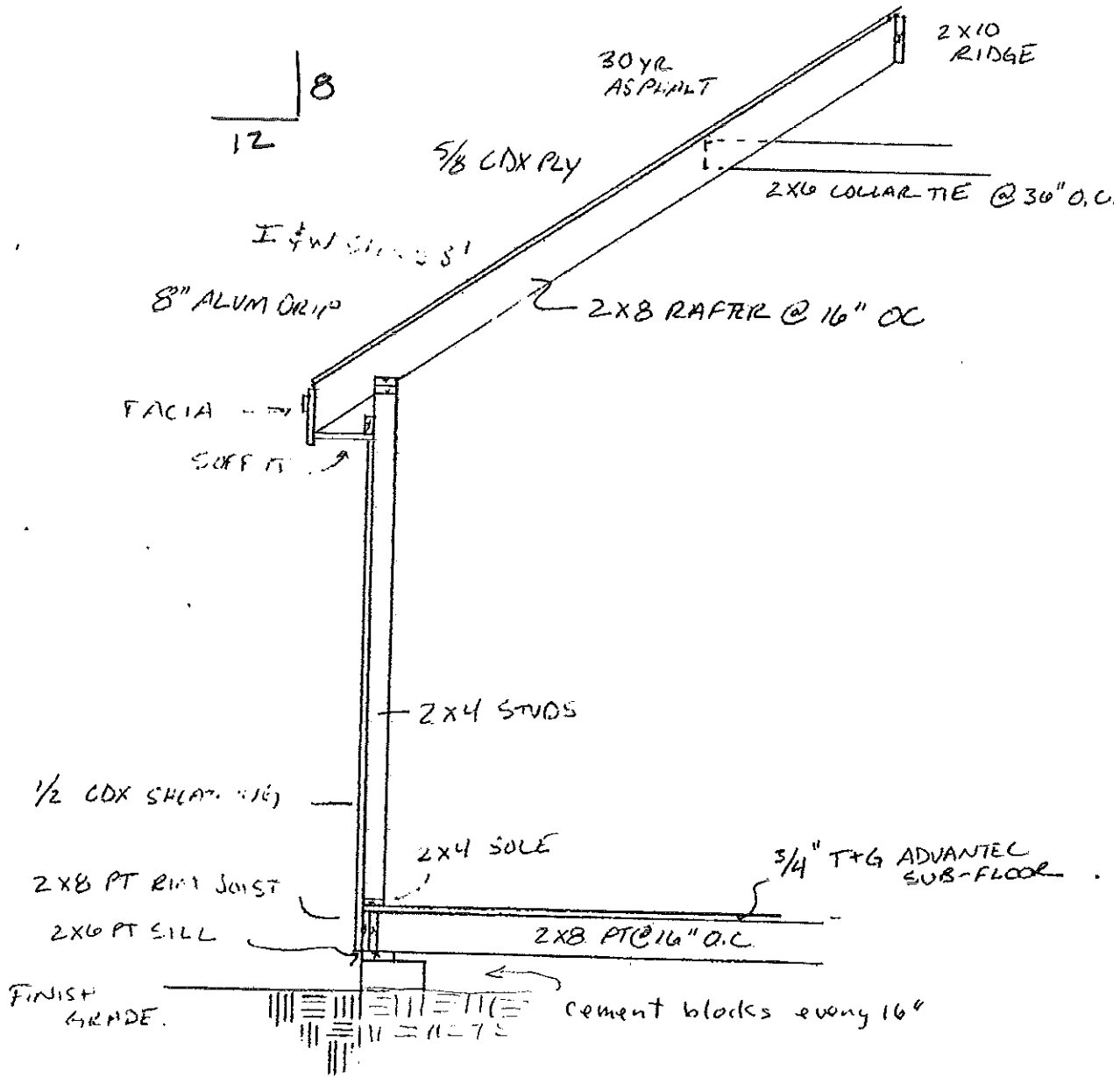

<u>Quantity</u>	<u>Description</u>
1	36" x 80" RH 9 Light, Solid Insulated Stanley TK4E Door with an R.O. 38 1/4 x 82
2	2'-5 5/8" x 3'-1 1/4" 12 Light, Double Hung Anderson 24210 Window with an R.O. 2'-6 1/8" x 3'-1 1/4"

City of Portland, Maine - Building or Use Permit

389 Congress Street, 04101 Tel: (207) 874-8703, Fax: (207) 874-8716

Permit No: 04-1664	Date Applied For: 11/05/2004	CBL: 418A A002001
------------------------------	--	-----------------------------

Location of Construction: 474 Presumpscot St	Owner Name: Devito Vincent G Wwii Vet &	Owner Address: 474 Presumpscot St	Phone:
Business Name:	Contractor Name: Owner	Contractor Address: Portland	Phone:
Lessee/Buyer's Name	Phone:	Permit Type: Sheds	

Proposed Use: Single Family Home / Install 220 Sq ft Shed	Proposed Project Description: Install 220 sq ft Shed
---	--

Dept: Zoning	Status: Approved	Reviewer: Jeanine Bourke	Approval Date: 11/16/2003
Note:			Ok to Issue: <input checked="" type="checkbox"/>
Dept: Building	Status: Approved	Reviewer: Jeanine Bourke	Approval Date: 11/16/2004
Note:			Ok to Issue: <input checked="" type="checkbox"/>

BUILDING PERMIT INSPECTION PROCEDURES

Please call 874-8703 or 874-8693 to schedule your inspections as agreed upon

Permits expire in 6 months, if the project is not started or ceases for 6 months.

The Owner or their designee is required to notify the inspections office for the following inspections and provide adequate notice. Notice must be called in 48-72 hours in advance in order to schedule an inspection:

By initializing at each inspection time, you are agreeing that you understand the inspection procedure and additional fees from a "Stop Work Order" and "Stop Work Order Release" will be incurred if the procedure is not followed as stated below.

A Pre-construction Meeting will take place upon receipt of your building permit.

- Footing/Building Location Inspection: Prior to pouring concrete
- Re-Bar Schedule Inspection: Prior to pouring concrete
- Foundation Inspection: Prior to placing ANY backfill
- Framing/Rough Plumbing/Electrical: Prior to any insulating or drywalling
- Final/~~Certificate of Occupancy~~: Prior to any occupancy of the structure or use. ~~NOTE: There is a \$75.00 fee per inspection at this point.~~

Certificate of Occupancy is not required for certain projects. Your inspector can advise you if your project requires a Certificate of Occupancy. All projects DO require a final inspection

If any of the inspections do not occur, the project cannot go on to the next phase, **REGARDLESS OF THE NOTICE OR CIRCUMSTANCES.**

NA **CERIFICATE OF OCCUPANICES MUST BE ISSUED AND PAID FOR, BEFORE THE SPACE MAY BE OCCUPIED**

Quil Ober
Signature of Applicant/Designee

11/17/04
Date

Carrie M. Burke
Signature of Inspections Official

11/17/04
Date

CBL: 418 AA002 Building Permit #: 041664

BUILDING PERMIT INSPECTION PROCEDURES

Please call 874-8703 or 874-8693 to schedule your inspections as agreed upon

Permits expire in 6 months, if the project is not started or ceases for 6 months.

The Owner or their designee is required to notify the inspections office for the following inspections and provide adequate notice. Notice must be called in 48-72 hours in advance in order to schedule an inspection:

By initializing at each inspection time, you are agreeing that you understand the inspection procedure and additional fees from a "Stop Work Order" and "Stop Work Order Release" will be incurred if the procedure is not followed as stated below.

A Pre-construction Meeting will take place upon receipt of your building permit.

- NA Footing/Building Location Inspection: Prior to pouring concrete (after fact permit)
- NA Re-Bar Schedule Inspection: Prior to pouring concrete
- NA Foundation Inspection: Prior to placing ANY backfill
- NA Framing/Rough Plumbing/Electrical: Prior to any insulating or drywalling
- Final Certificate of Occupancy: (already Built) Prior to any occupancy of the structure or use. NOTE: There is a \$75.00 fee per inspection at this point.

Certificate of Occupancy is not required for certain projects. Your inspector can advise you if your project requires a Certificate of Occupancy. All projects DO require a final inspection

NA If any of the inspections do not occur, the project cannot go on to the next phase, REGARDLESS OF THE NOTICE OR CIRCUMSTANCES.

NA CERTIFICATE OF OCCUPANICES MUST BE ISSUED AND PAID FOR, BEFORE THE SPACE MAY BE OCCUPIED

[Signature] Signature of Applicant/Designee Date 1/6/05
[Signature] Signature of Inspections Official Date 01/6/05

CBL: 418AA001 Building Permit #: 04 1758