

PERMIT ISSUED

City of Portland, Maine - Building or Use Permit Application
 389 Congress Street, 04101 Tel: (207) 874-8703, Fax: (207) 874-8716

Permit No: 02-0619	Issue Date: JUN 18 2002	CBL: 406 G009001
-----------------------	----------------------------	---------------------

Location of Construction: 105 Florida Ave	Owner Name: Laplante Carole Ann	Owner Address: 105 Florida Ave	Phone: 207-797-7668
Business Name: n/a	Contractor Name: n/a	Contractor Address: Portland	Phone:
Lessee/Buyer's Name n/a	Phone: n/a	Permit Type: Swimming Pools	Zone:

Past Use: Single Family	Proposed Use: Single Family / Install 18' x 48' Above the ground pool.	Permit Fee: \$37.00	Cost of Work: \$1,500.00	CEO District: 2
		FIRE DEPT: <input type="checkbox"/> Approved <input checked="" type="checkbox"/> Denied <i>N/A</i>	INSPECTION: Use Group: <i>U</i> Type: <i>POOL</i> <i>BOCA 1999</i>	

Proposed Project Description:
Install 18' x 48' Above the Ground Pool

Signature: *[Signature]*

Signature: *[Signature]*

PEDESTRIAN ACTIVITIES DISTRICT (P.A.D.)

Action: Approved Approved w/Conditions Denied

Signature: *N/A* Date:

Permit Taken By: gg	Date Applied For: 06/07/2002	Zoning Approval	
------------------------	---------------------------------	------------------------	--

<p>1. This permit application does not preclude the Applicant(s) from meeting applicable State and Federal Rules.</p> <p>2. Building permits do not include plumbing, septic or electrical work.</p> <p>3. Building permits are void if work is not started within six (6) months of the date of issuance. False information may invalidate a building permit and stop all work..</p>	<p>Special Zone or Reviews</p> <p><input type="checkbox"/> Shoreland</p> <p><input type="checkbox"/> Wetland</p> <p><input type="checkbox"/> Flood Zone</p> <p><input type="checkbox"/> Subdivision</p> <p><input type="checkbox"/> Site Plan</p> <p>Maj <input type="checkbox"/> Minor <input type="checkbox"/> MM <input type="checkbox"/></p> <p>Date: <i>6/17/02</i></p>	<p>Zoning Appeal</p> <p><input type="checkbox"/> Variance</p> <p><input type="checkbox"/> Miscellaneous</p> <p><input type="checkbox"/> Conditional Use</p> <p><input type="checkbox"/> Interpretation</p> <p><input type="checkbox"/> Approved</p> <p><input type="checkbox"/> Denied</p> <p>Date:</p>	<p>Historic Preservation</p> <p><input checked="" type="checkbox"/> Not in District or Landmark</p> <p><input type="checkbox"/> Does Not Require Review</p> <p><input type="checkbox"/> Requires Review</p> <p><input type="checkbox"/> Approved</p> <p><input type="checkbox"/> Approved w/Conditions</p> <p><input type="checkbox"/> Denied</p> <p>Date: <i>6/17/02</i></p>
---	--	---	---

CERTIFICATION

I hereby certify that I am the owner of record of the named property, or that the proposed work is authorized by the owner of record and that I have been authorized by the owner to make this application as his authorized agent and I agree to conform to all applicable laws of this jurisdiction. In addition, if a permit for work described in the application is issued, I certify that the code official's authorized representative shall have the authority to enter all areas covered by such permit at any reasonable hour to enforce the provision of the code(s) applicable to such permit.

SIGNATURE OF APPLICANT _____ ADDRESS _____ DATE _____ PHONE _____

RESPONSIBLE PERSON IN CHARGE OF WORK, TITLE _____ DATE _____ PHONE _____

All Purpose Building Permit Application

If you or the property owner owes real estate or personal property taxes or user charges on any property within the City, payment arrangements must be made before permits of any kind are accepted.

Location/Address of Construction: <u>105 Florida Ave Portland ME 04103</u>		
Total Square Footage of Proposed Structure	Square Footage of Lot <u>800 sq. ft</u>	
Tax Assessor's Chart, Block & Lot Chart# <u>460</u> Block# _____ Lot# <u>69410</u>	Owner: <u>Carole Ann LaPlante</u>	Telephone: <u>797-7668</u>
Lessee/Buyer's Name (if Applicable)	Applicant name, address & telephone: <u>Carole A. LaPlante</u> <u>105 Florida Ave</u> <u>Portland Me</u> <u>04103 - 797-7668</u>	Cost Of Work: \$ <u>1,500</u> Fee: \$ <u>37-</u>
What size is the pool: <u>18 x 48</u> Above or below ground: <u>Above</u>		
Dimensions of decking and/or platforms: <u>N/A</u>		
Contractor's name, address & telephone:		
Who should we contact when the permit is ready: <u>Carole A. LaPlante</u>		
Mailing address: <u>105 Florida Ave</u> <u>Portland, ME 04103</u>		
We will contact you by phone when the permit is ready. You must come in and pick up the permit and review the requirements before starting any work, with a Plan Reviewer. A stop work order will be issued and a \$100.00 fee if any work starts before the permit is picked up. PHONE: <u>797-7668</u>		

IF THE REQUIRED INFORMATION IS NOT INCLUDED IN THE SUBMISSIONS THE PERMIT WILL BE AUTOMATICALLY DENIED AT THE DISCRETION OF THE BUILDING/PLANNING DEPARTMENT, WE MAY REQUIRE ADDITIONAL INFORMATION IN ORDER TO APPROVE THIS PERMIT.

I hereby certify that I am the Owner of record of the named property, or that the owner of record authorizes the proposed work and that I have been authorized by the owner to make this application as his/her authorized agent. I agree to conform to all applicable laws of this jurisdiction. In addition, if a permit for work described in this application is issued, I certify that the Code Official's authorized representative shall have the authority to enter all areas covered by this permit at any reasonable hour to enforce the provisions of the codes applicable to this permit.

Signature of applicant: <u>Carole A. LaPlante</u>	Date: <u>6-6-02</u>
---	---------------------

This is NOT a permit; you may not commence ANY work until the permit is issued. If you are in a Historic District you may be subject to additional permitting and fees with the Planning Department on the 4th floor of City Hall

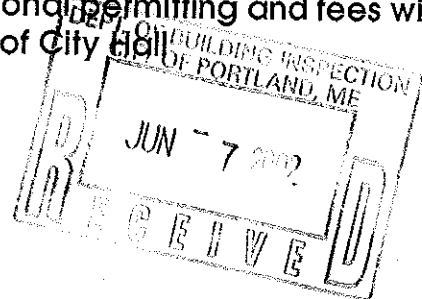

MIGHTY SUN

SILVER OAK

18 FT w/ fence around ground railing

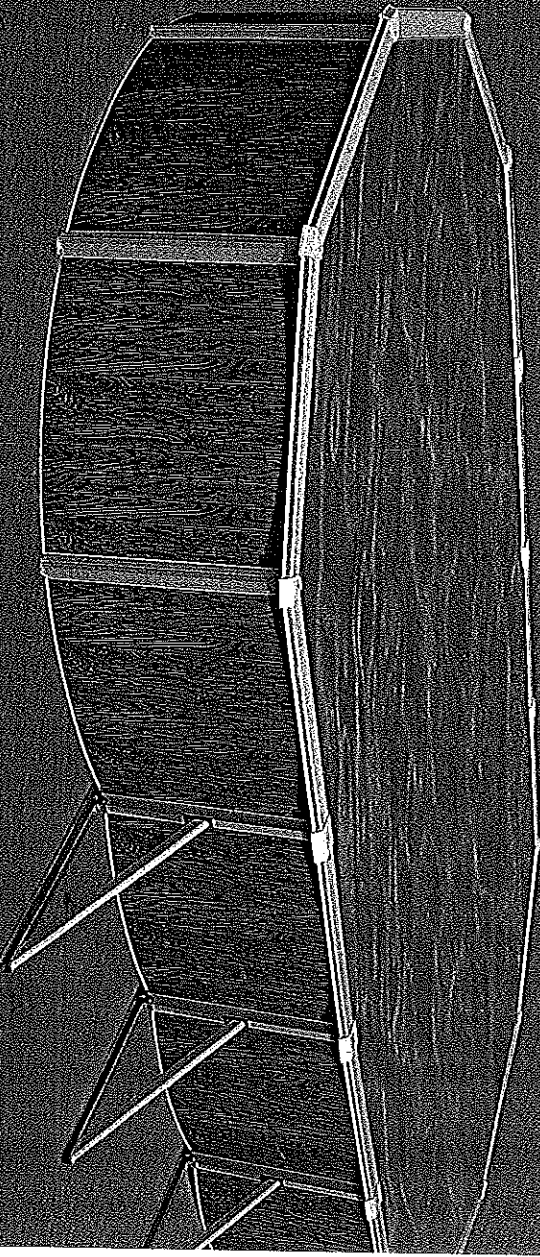
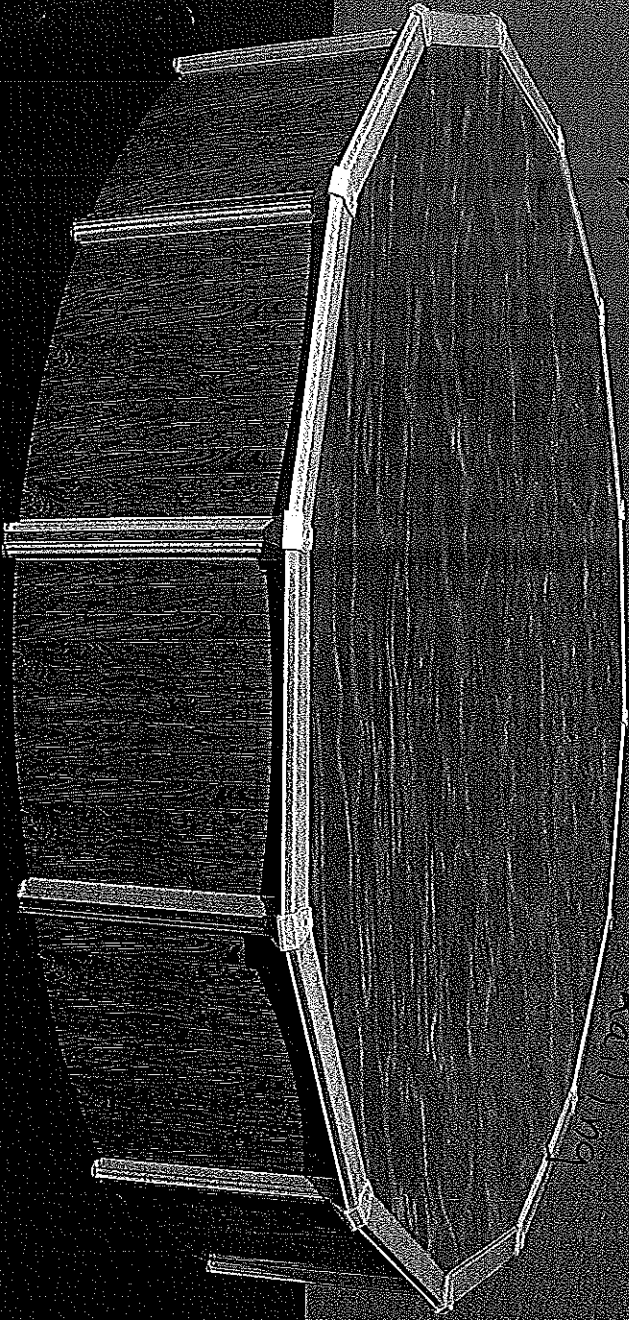



SILVER OAK

15 YEAR LIMITED WARRANTY
POLYESTER BAKED ENAMEL WALL AND FRAME

MIGHTY SUN Painted Frame and wall finishes especially formulated for exterior use in all climate conditions. **2-COAT 2-BAKE POLYESTER ENAMEL ON COPPER-BEARING HOT-DIPPED GALVANIZED STEEL**. **HOT-dipped galvanized steel** chemically pre-treated to increase paint-to-steel adhesion and corrosion resistance. **steel is prime-coated with epoxy resin paint and baked**. Finish coat of polyester resin paint is applied and baked. This process results in a high gloss hard enamel finish with high resistance to fading, chipping and cracking. The durability of **MIGHTY SUN'S** painted steel frames and walls is backed by wide use of the same finished steel as roofing and siding for buildings as well as on home appliances.

FEATURES

WALL:
Wood-tone lithograph over baked polyester enamel. G-90 Hot-Dipped Galvanized. Deep grooved corrugation for maximum strength.

FRAME:
High-gloss baked polyester enamel Top Seats and Uprights. VINYLEBOND steel Seat Covers.

ASSEMBLY:
Machine-threaded fittings on all joint assemblies secured by machined screws for ease of assembly and maximum sturdiness. Inter locking top and bottom rims give added support and a unitized assembly.

NOTE:
All dimensions and specifications are approximate and are expressed to the nearest foot. ASAHI CHEMICAL reserves the right to make changes at any time, without notice, in color, specifications, prices and also to discontinue models.



STANDARD-6 SERIES		SUPER-7 SERIES	
CATALOG NO.	6TH-WS/SOS	CATALOG NO.	7H-WS/SOS
TOP SEATS:	6-IN White	7-IN White	
UPRIGHTS:	5 1/4x2-IN White	6 1/2x2 1/2 White	
TOP RAILS:	5/8-IN	1-IN	
BOTTOM RAILS:	5/8-IN	1-IN	
TOP COVERS:	1-PC White	2-PC White	
ROUND POOLS			
12x48	3375 GALS		
15x48	5200 "		
18x48	7655 "		
21x48	10400 "		
24x48	13500 "		
27x48	17100 "		
OVAL POOL			
24x12x48	7860 GALS		
25x15x48	9600 "		
30x15x48	12000 "		
33x18x48	16000 "		
41x21x48	23000 "		
PROFILE OVALS -For small backyards and lots where space is a problem.			
18x12x48P	5760 GALS		
24x12x48P	7860 "		
25x15x48P	9600 "		
30x15x48P	12000 "		
33x18x48P	16000 "		

CAUTION:
THESE POOLS ARE DESIGNED FOR SWIMMING ONLY.
THEY ARE NOT DESIGNED FOR ANY KIND OF DIVING OR JUMPING.

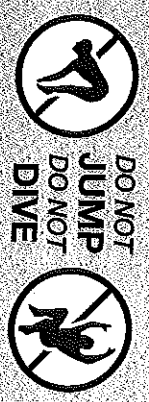

ASAHI CHEMICAL INDUSTRY CO., LTD.
P.O. BOX 1271 KINGSTON, PA. 18704-0271
Phone: (717)-331-4814 FAX: (717)-331-4815

House

Fence

10
GRASS walkway

DRIVEWAY

GARAGE

side stairs
arching

15 ft

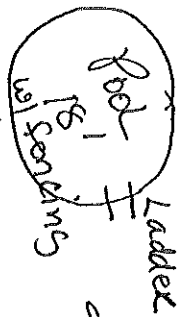

tree
14 ft

27 ft → →

8x8 deck

Back yard 50 ft

House 20 ft

Front yard 30 ft

grass

DOOR

tree

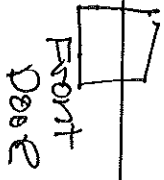

ALL GROWN UP w/ SHRUBS/TREES

Street

House

Carole Kaufman
105 Florida Ave, Portland - 99227668

Pool w/ 2ft High built-in fence

Ladder - A Frame -

Stationary or
Removable -

Stairs of ladder
slide up & lock
or remove completely

Pool Alarm attached to

inside - under
water of pool
weight of 15lbs
& sounds alarm
also w/ portable
monitor

* w/ 10z Ladder Protection
will be dropped off on fence
by applicant

A-FRAME LADDER ASSEMBLY INSTRUCTIONS

TOOLS REQUIRED FOR ASSEMBLY: PHILLIPS SCREWDRIVER, FLAT BLADE SCREWDRIVER, DRILL WITH 7/16" BIT, 7/16 & 9/16 SOCKETS, BOX OR OPEN END WRENCHES, TAPE MEASURE, STUBBY PENCIL

Ladder Can be Changed up and locked or Remanded to prevent access to the Pool.

Can't Robots Store manager

- 1) LABEL "DO NOT SWIM THRU, BEHIND OR AROUND"
- 2) LABEL "NO JUMPING - NO DIVING"
- 3) LABEL "REMOVE WHEN NOT IN USE"

A) 3/4" X 4" CARRIAGE BOLT	8
B) 3/8" HEX NUT	8
C) 3/8 FLAT WASHER	10
D) #14 X 3/4" TAPPING SCREW	6
E) 3/8 X 3" MACHINE SCREW	2
F) 3/8 NYLON INSERT NUT	2
G) 1/4 X 2-1/4" PHILLIPS SCREW	2
H) 1/4 ACORN NUT	2
I) 1/4 FLAT WASHER	2

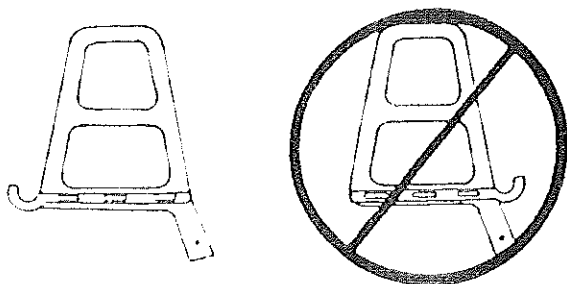
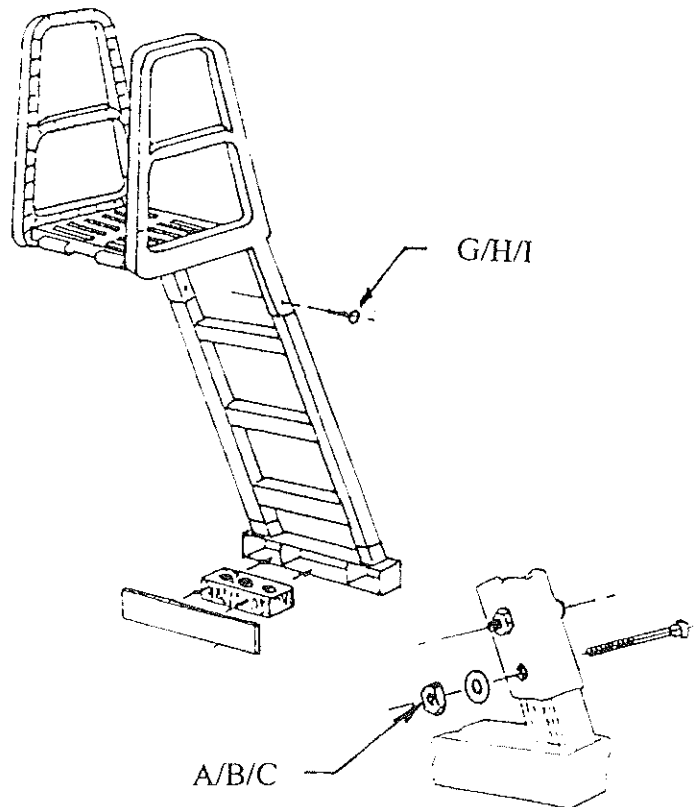
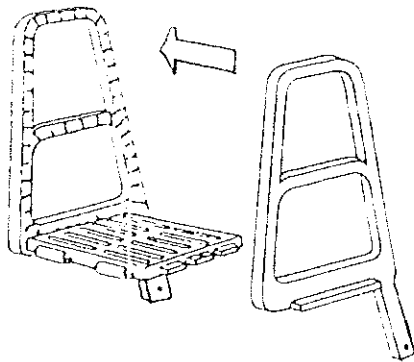
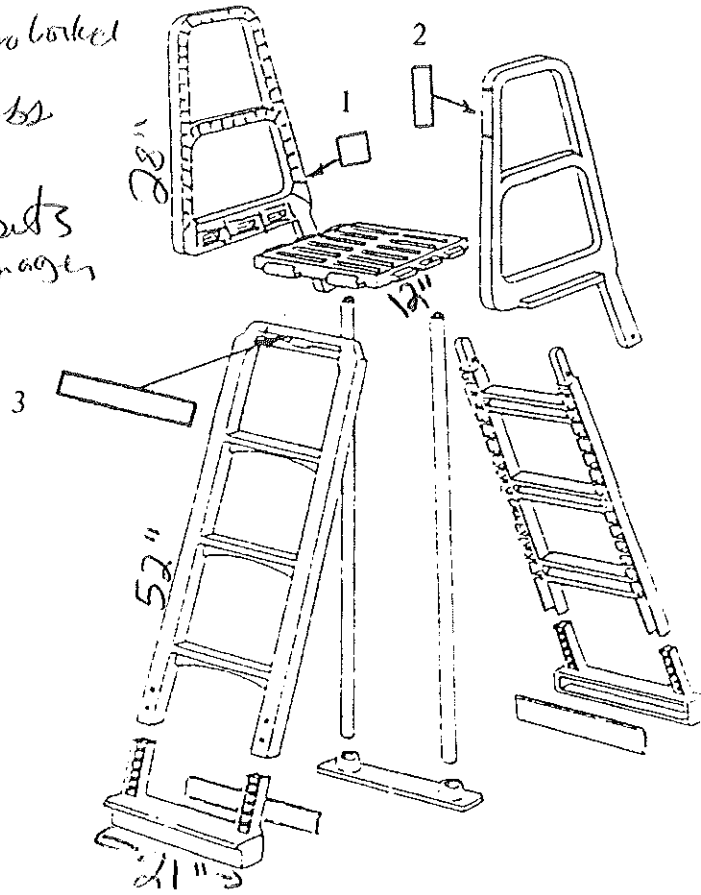

ANNUAL SAFETY LADDER

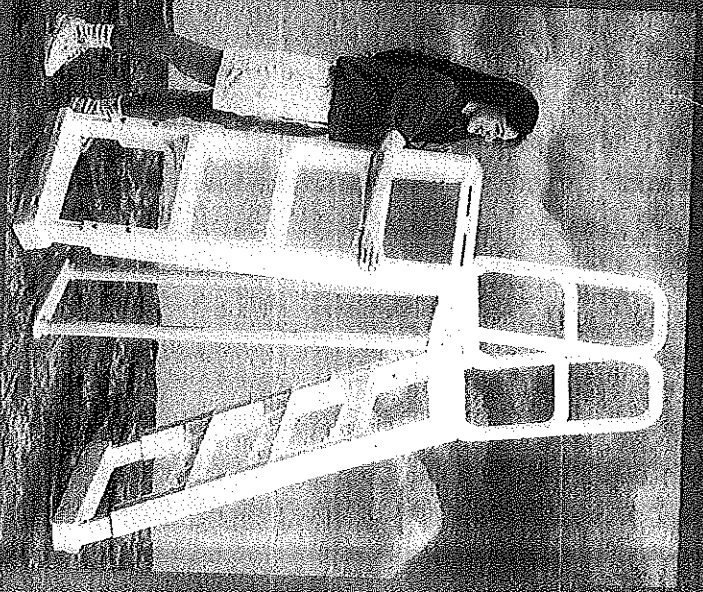

A-Frame Safety Ladder, #200230
Height Adjustable

- Lift-off, anti-slip safety steps
- Fully adjustable legs level ladder for safer entry
- Extra high "climb rails" provide comfortable, stable hand placement
- Anchor legs, provides extra platform support for user stability and confidence
- High density, structural plastic supports more than 350 lbs.

EASY INCLINE DECK LADDER

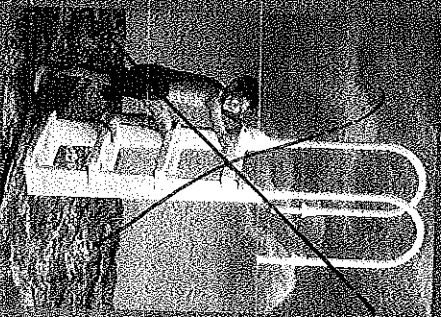

Easy Incline Deck Ladder, #210200
Extra Wide Extra Deep Steps

- Steps progress from 9" to 6 1/2" depth for easier entry and exit
- Extra high, extra strong, climb rails, provide stable hand placement and more support
- Over sized base helps stabilize gate for all users
- High density, structural plastic supports more than 350 lbs.

EASY ENTRY STEP

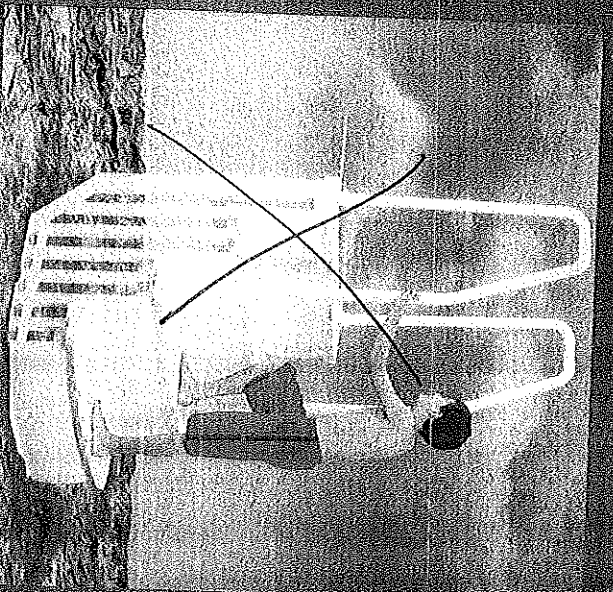

Easy Entry Step Model, #200400
BOCA CODE * ANSI STANDARD

- 36" wide, 10" deep steps provide "easy entry" into the pool
- Extra high, extra strong "climb rails" provide stable hand placement and more support
- BOCA code design eases swim behind concerns
- Assembles in minutes
- High density, structural plastic supports more than 350 lbs.

Pro Series Deck Ladder, #200300

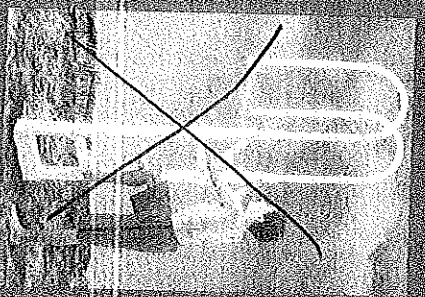

- Extra high, extra strong, climb rails, provide stable hand placement and more support
- All adjust to virtually any pool or deck height
- High density, structural plastic supports more than 350 lbs.

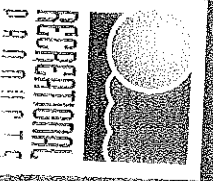

TAKE A STEP ONTO QUALITY

1-888-333-1134

Blanswick, Ohio

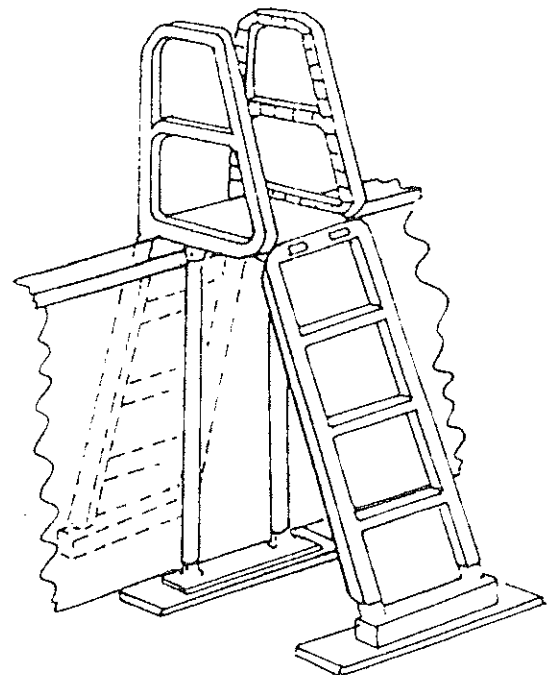
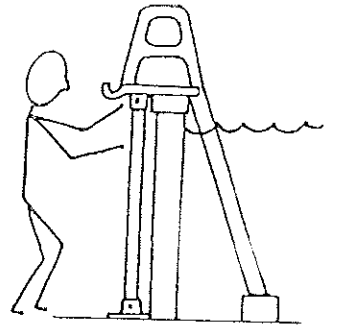
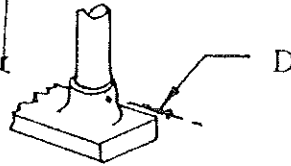
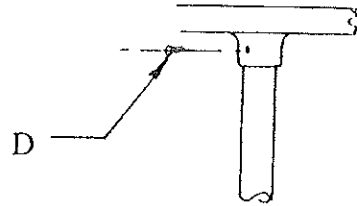
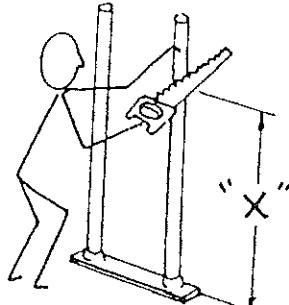
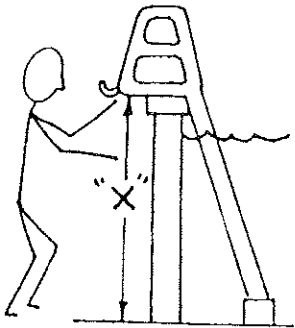
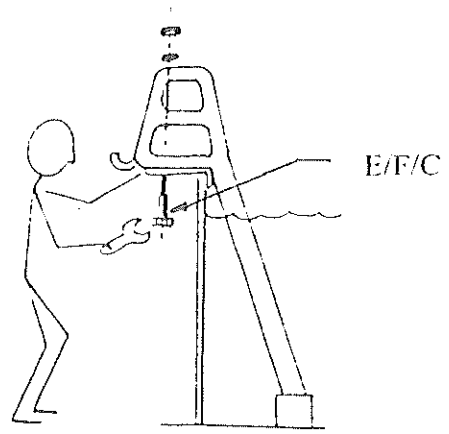
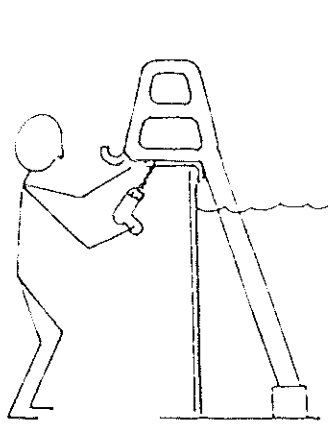

Model 2000 Entry System

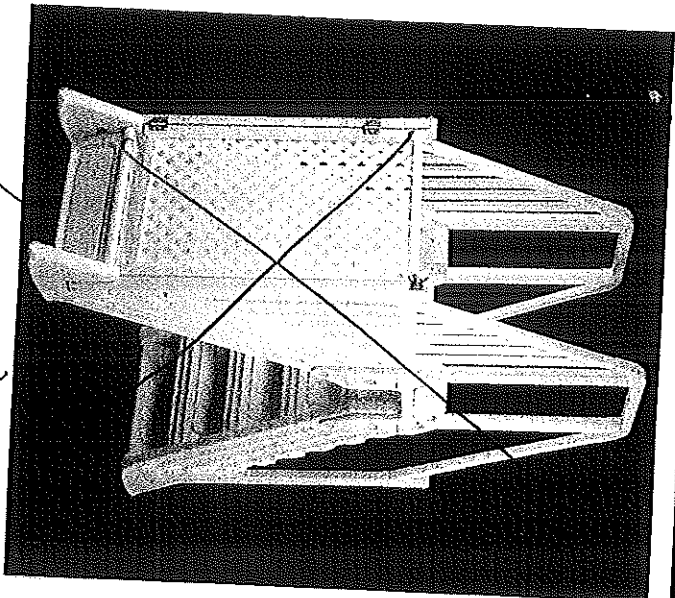

- Produced from maintenance free vinyl
- Can be used with 48" - 52" pools
- Double handrails and five full treads on both sides of the unit for easy entry and exit
- One-piece top platform to protect the top rail of the pool
- The gate is spring-loaded, self-closing, self-latching and lockable for pool security
- Designed to meet code requirements for pool entry systems
- Engineered for easy assembly, most components simply snap together
- Can be used with both models of our Pool Fencing to totally enclose and secure pool

Model 494 Ladder Enclosure

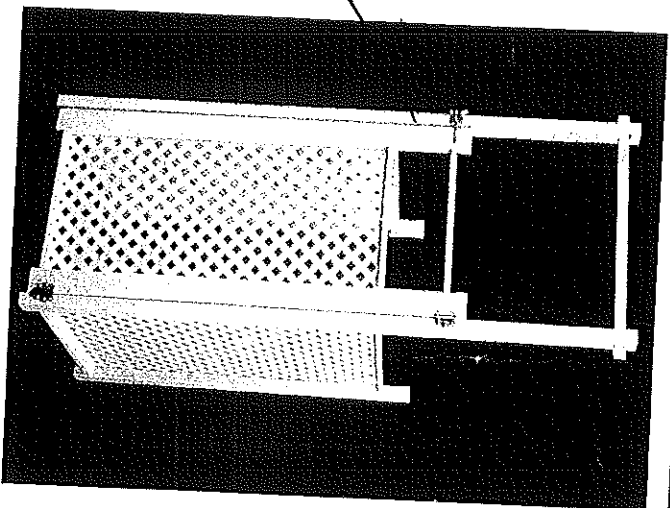

- Produced from maintenance free vinyl
- This three-sided enclosure is designed to be used with conventional a-frame ladders and to meet all code requirements
- The gate is spring-loaded, self closing, self-latching and lockable for pool security
- The enclosure is packaged sub-assembled for easy installation
- Can be used with both models of our Pool Fencing to totally enclose and secure pool

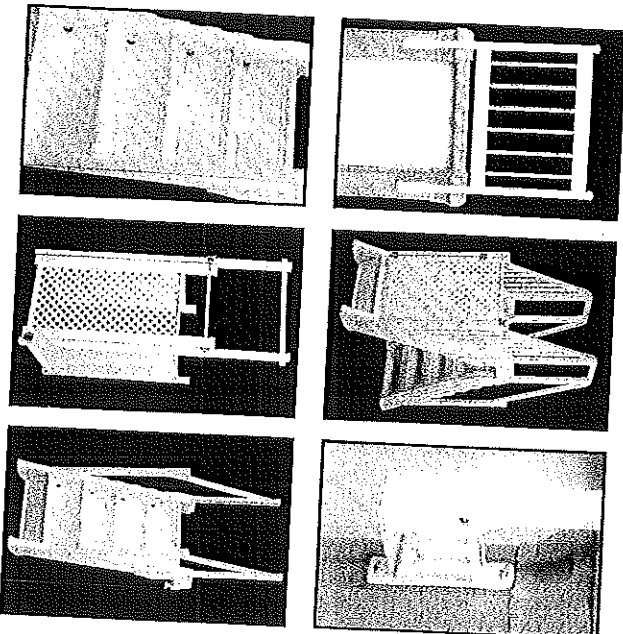

Vinyl Works Canada

quality by design

P.O. Box 490, 399 Gorham Road, Ridgeway, Ontario Canada L0S 1N0
 1-877-VINYL W/K
 Phone: 905-894-4433 / Fax: 905-894-5115
 Email: office@vinylworkscanada.com
 www.vinylworkscanada.com

pool fencing
stair entry systems

ladder enclosures

quality by design

ALL RESIN LADDER ENCLOSURE

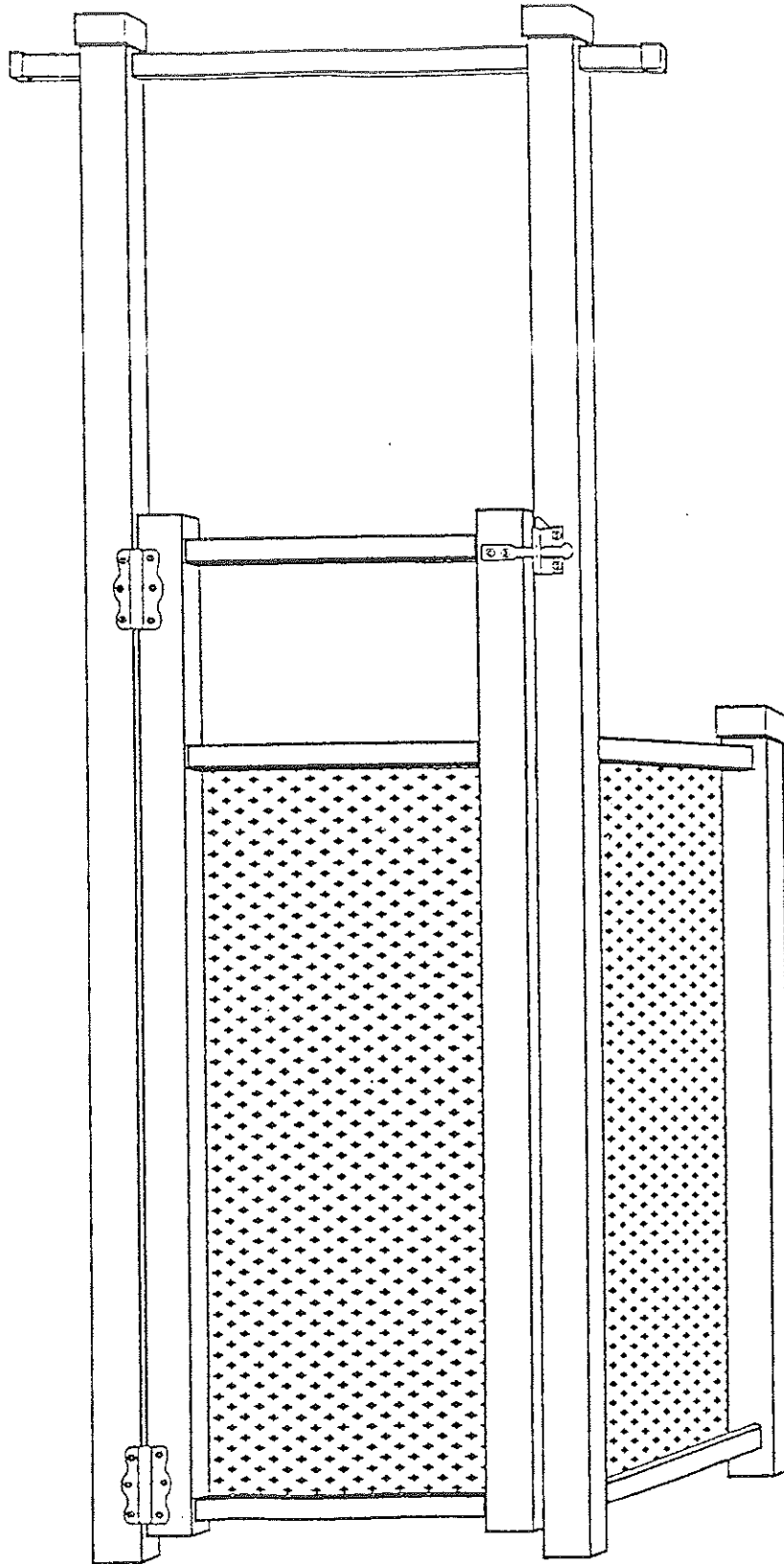

VINYL WORKS CANADA
quality by design

MODEL 494-LE LADDER ENCLOSURE
BILL OF MATERIAL
AND
PACKAGE BREAKDOWN

The Model 494-LE Ladder Enclosure is packaged in one carton, contents of which are as follows:

- 1 – Left side frame (assembled)
- 1 – Right side frame (assembled)
- 1 – Gate (assembled)
- 2 – Vertical support legs (with belled ends)
- 3 – Cross support bars
- 1 – Hardware pack

Hardware pack consists of the following:

- 2 – Spring-loaded hinges
- 1 – Gate latch & striker
- 6 – 2x4 white caps
- 2 – 7/8 x 1-1/2 white caps
- 2 – “L” brackets
- 12 - #10 x 1” screws (for gate latch)
- 30 - # 8 x 3/4 screws (for cross members, latch, “L” brackets & vertical legs)
- 8 – Snap caps & washers
- 1 – Instruction sheet

LADDER ENCLOSURE SPECIFICATIONS

- Vinyl Works Canada manufactures the Model 494-LE Ladder Enclosure to meet or exceed BOCA / ANSI / NSPI code requirements for ladder enclosures
- The Model 494-LE Ladder Enclosure is manufactured using maintenance free resins for years of worry-free enjoyment
- The enclosure is packaged in one box with the side frames and gate fully assembled to make for a quick and easy installation
- The Model 494-LE enclosure has an optional 4th Side panel which can be ordered separately. The 4th Side is attached to the rear of the unit to eliminate access when used with a pool deck. When installed access to the pool is totally secured
- Spring-loaded, self-closing, self-latching and lockable gate hardware is packaged with the unit. The unit can be locked to deny access when not in use
- The gate on the enclosure is to open outward as per the installation instructions
- The side frames and the gate come pre-assembled using vinyl lattice which is smooth, has no sharp edges and has opening spaces of 1" square
- The side frame height of the ladder enclosure measures 48" from the top of the top rail to the bottom of the bottom rail. The installation instructions specify that the space beneath the bottom rail to the ground not exceed 2"
- The width of the unit measures 33", large enough to accommodate most a-frame ladders
- The overall depth of the enclosure measures 40"
- The gate measures 29" wide
- The gate height measures 57-½" from the top of the top rail to the bottom of the bottom rail. When installed on the unit, the gate latch measures 58" from the ground
- The ladder enclosure installation instructions specify that the unit be placed directly against the pool wall, surrounding the entrance ladder, to eliminate any opening between the pool and the enclosure. Brackets are included with the hardware to secure the unit to the top rail of the pool to keep it in place
- We recommend that the ladder enclosure be used with either of our Pool Fencing heights so that the entire pool can be enclosed for greater security. The use of our Closure Kits enables you to join the Pool Fencing directly to the Ladder Enclosure leaving no open areas to the swimming pool
- Vinyl Works Canada reserves the right to change or alter the manufacturing specifications within the specified code requirements. If there should be any questions regarding this or any of our products please do not hesitate to contact our customer service department at toll free 1-877-VINYL WK

REMEMBER, NOTHING REPLACES PARENTAL SUPERVISION

MODEL 494-LE LADDER ENCLOSURE

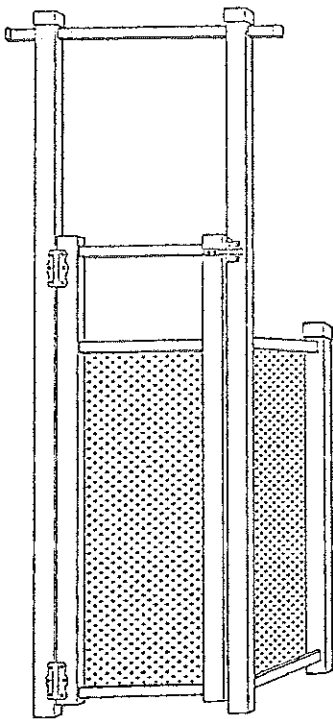

1

ASSEMBLE THREE CROSS SUPPORT BARS AT TOP, BOTTOM & REAR BY INSTALLING SCREWS INTO PREDRILLED HOLES AS SHOWN. SIMILAR ALL LOCATIONS. CONNECT VERTICAL SUPPORT LEGS TO LEFT & RIGHT SIDE FRAMES AS SHOWN KEEPING LATTICE TO THE INSIDE FACE.

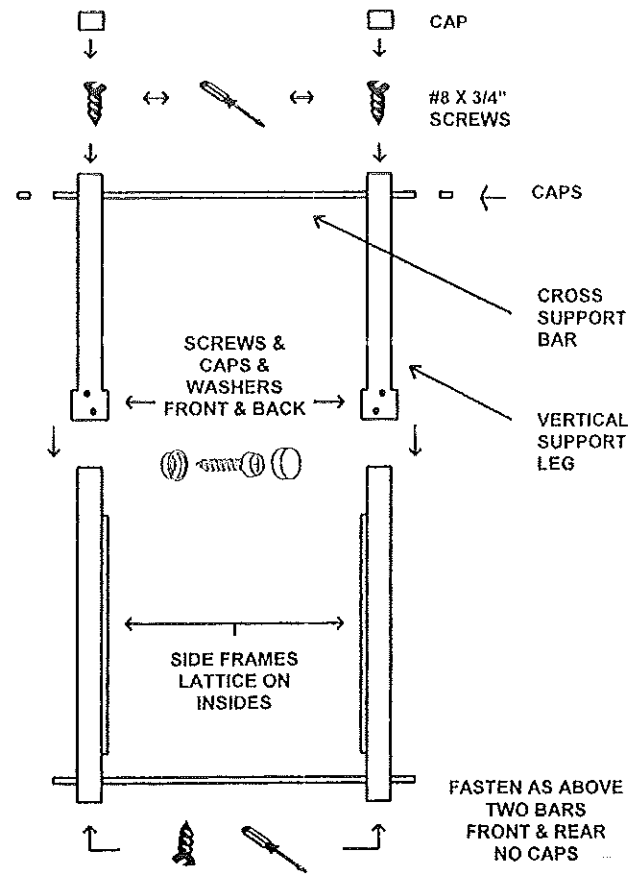

2

FASTEN GATE INTO FRONT OPENING OF ENCLOSURE. MAKE CERTAIN TO KEEP TOP OF LATTICE IN LINE WITH LATTICE OF SIDE FRAMES. LEAVE A SMALL GAP ON BOTH SIDES OF THE GATE AND MARK HOLE LOCATIONS. PREDRILL 1/8\"

3

SET ENCLOSURE IN PLACE AGAINST POOL. BURY THE TWO BOTTOM CROSS SUPPORTS IN THE EARTH FOR GREATER STABILITY. LEAVE NO MORE THAN A 2\"

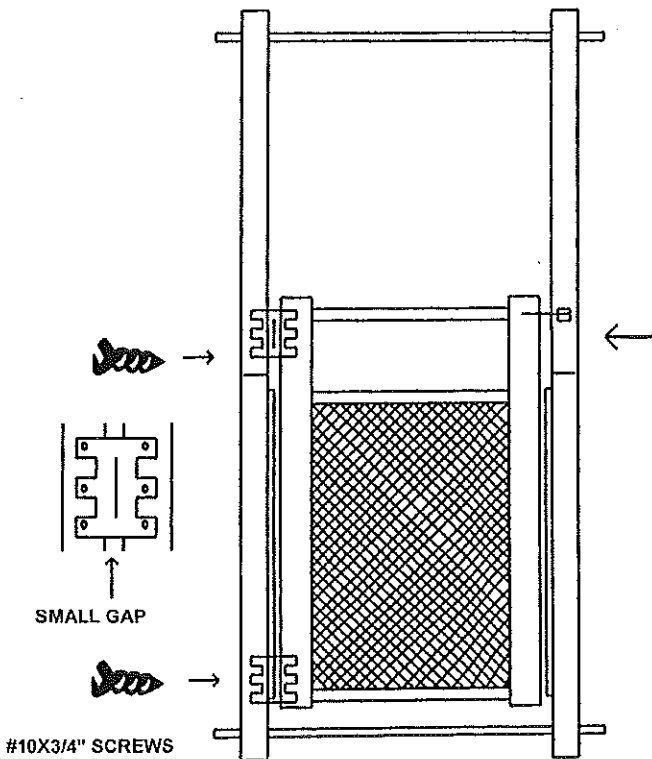

GATE LATCH



#8 X 3/4\"

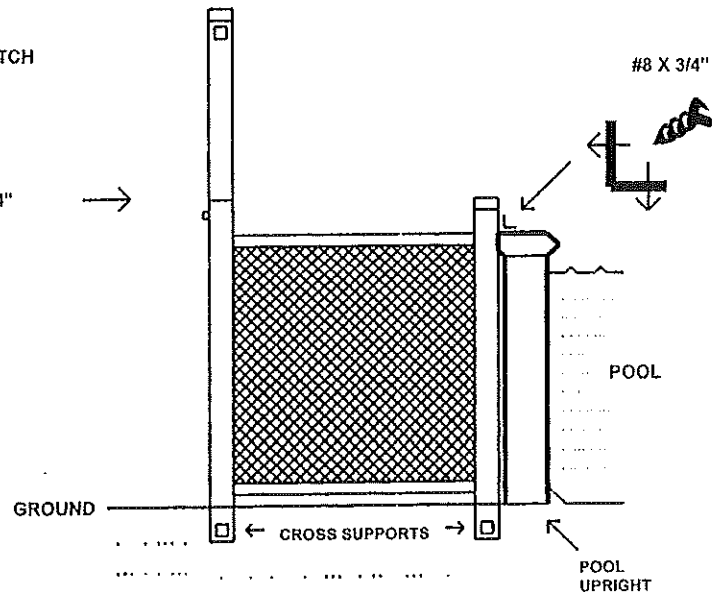

VINYL WORKS CANADA

QUALITY BY DESIGN

P.O. BOX 490, 399 GORHAM ROAD
RIDGEWAY, ONTARIO, CANADA L0S 1N0
PH: 905-894-4433 / FAX: 905-894-5115

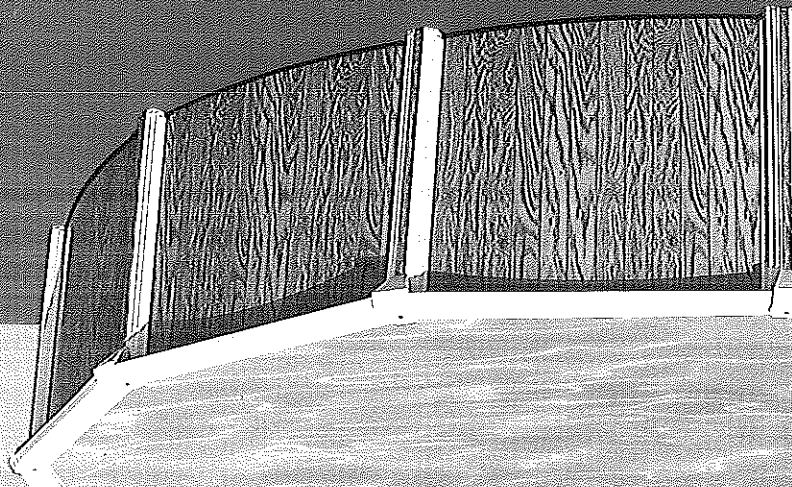

at High
ing all around railing

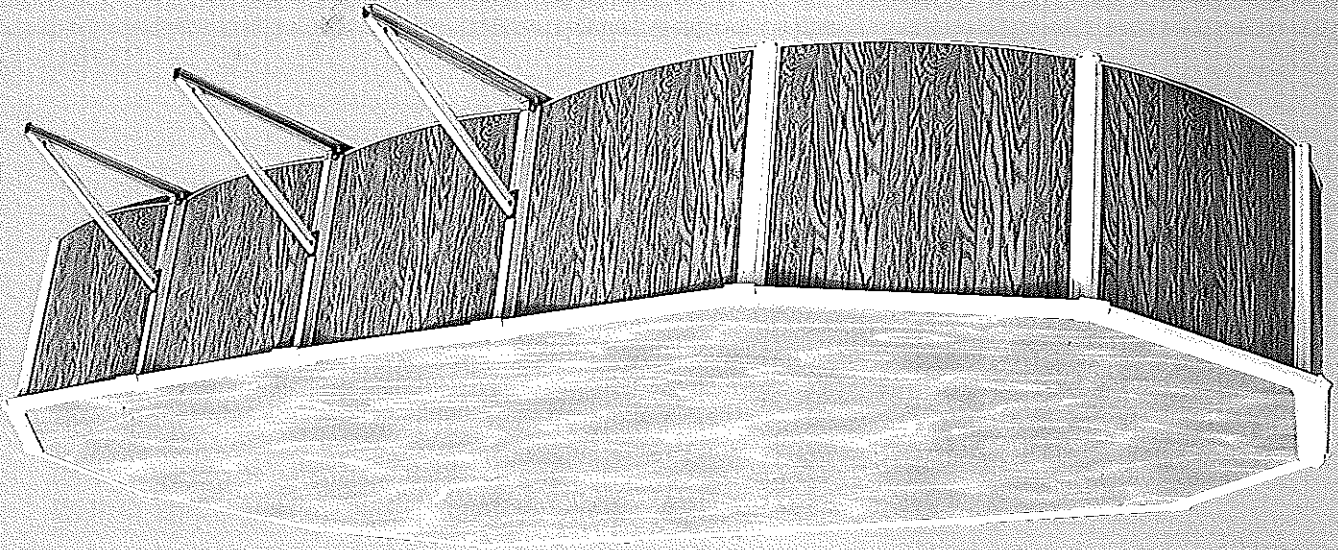

SILVER OAK

3
4

BUILDING PERMIT INSPECTION PROCEDURES

Please call 874-8703 or 874-8693 to schedule your

inspections as agreed upon

Permits expire in 6 months, if the project is not started or ceases for 6 months.

The Owner or their designee is required to notify the inspections office for the following inspections and provide adequate notice. Notice must be called in 48-72 hours in advance in order to schedule an inspection:

By initializing at each inspection time, you are agreeing that you understand the inspection procedure and additional fees from a "Stop Work Order" and "Stop Work Order Release" will be incurred if the procedure is not followed as stated below.

Pre-construction Meeting: Must be scheduled with your inspection team upon receipt of this permit. ~~John Reynolds~~, Development Review Coordinator at 874-8632 must also be contacted at this time, before any site work begins on any project other than single family additions or alterations.

Footing/Building Location Inspection: Prior to pouring concrete

Re-Bar Schedule Inspection: Prior to pouring concrete

Foundation Inspection: Prior to placing ANY backfill

Framing/Rough Plumbing/Electrical: Prior to any insulating or drywalling

Final/Certificate of Occupancy: Prior to any occupancy of the structure or use. NOTE: There is a \$75.00 fee per inspection at this point.

Certificate of Occupancy is not required for certain projects. Your inspector can advise you if your project requires a Certificate of Occupancy. All projects DO require a final inspection

_____ If any of the inspections do not occur, the project cannot go on to the next phase, REGARDLESS OF THE NOTICE OR CIRCUMSTANCES.

_____ **CERIFICATE OF OCCUPANICES MUST BE ISSUED AND PAID FOR, BEFORE THE SPACE MAY BE OCCUPIED**

Clark A. LaPorte
Signature of applicant/designee

6-19-02
Date

[Signature]
Signature of Inspections Official

6/19/02
Date

CBL: 406-6-9 Building Permit #: 02-01019