

**City of Portland, Maine - Building or Use Permit Application**  
 389 Congress Street, 04101 Tel: (207) 874-8703, Fax: (207) 874-8716

Permit No: 05-1590	Issue Date: NOV 15 2005	CBL: 428 L002001
Owner Name: GIROUX JAMES R	Owner Address: PO BOX 11082	Phone:
Contractor Name: Caron & Waltz	Contractor Address: 321 Lincoln Street South Portland	Phone: 2077992228
Permit Type: HVAC	Zone: R5	

Location of Construction: 20 PRESUMPCOT ST	Owner Name: GIROUX JAMES R	Owner Address: PO BOX 11082
Business Name:	Contractor Name: Caron & Waltz	Contractor Address: 321 Lincoln Street South Portland
Lessee/Buyer's Name	Phone:	Permit Type: HVAC

Past Use: Residential 3 unit	Proposed Use: Residential 3 unit / install a Smith 8W4T replacement boiler in basement
Proposed Project Description: install a Smith 8W4T replacement boiler in basement	

Permit Fee: \$75.00	Cost of Work: \$5,425.00	CEO District: 4
FIRE DEPT: <input checked="" type="checkbox"/> Approved <input type="checkbox"/> Denied	INSPECTION: Use Group: R2 Type: HVAC	
Signature: J. K. R.P.D. 10/28/05	Signature: JMB	
PEDESTRIAN ACTIVITIES DISTRICT (P.A.D.)		
Action: <input type="checkbox"/> Approved <input type="checkbox"/> Approved w/Conditions <input type="checkbox"/> Denied		
Signature: _____ Date: _____		

Permit Taken By: Idobson	Date Applied For: 10/26/2005
-----------------------------	---------------------------------

**Zoning Approval**

- This permit application does not preclude the Applicant(s) from meeting applicable State and Federal Rules.
- Building permits do not include plumbing, septic or electrical work.
- Building permits are void if work is not started within six (6) months of the date of issuance. False information may invalidate a building permit and stop all work..

<b>Special Zone or Reviews</b> <input type="checkbox"/> Shoreland <input type="checkbox"/> Wetland <input type="checkbox"/> Flood Zone <input type="checkbox"/> Subdivision <input type="checkbox"/> Site Plan <i>OK</i> Maj <input type="checkbox"/> Minor <input type="checkbox"/> MM <input type="checkbox"/> Date: <i>JMB 11/14/05</i>	<b>Zoning Appeal</b> <input type="checkbox"/> Variance <input type="checkbox"/> Miscellaneous <input type="checkbox"/> Conditional Use <input type="checkbox"/> Interpretation <input type="checkbox"/> Approved <input type="checkbox"/> Denied Date: _____	<b>Historic Preservation</b> <input checked="" type="checkbox"/> Not in District or Landmark <input type="checkbox"/> Does Not Require Review <input type="checkbox"/> Requires Review <input type="checkbox"/> Approved <input type="checkbox"/> Approved w/Conditions <input checked="" type="checkbox"/> Denied Date: <i>JMB</i>
---	---	--

**CERTIFICATION**

I hereby certify that I am the owner of record of the named property, or that the proposed work is authorized by the owner of record and that I have been authorized by the owner to make this application as his authorized agent and I agree to conform to all applicable laws of this jurisdiction. In addition, if a permit for work described in the application is issued, I certify that the code official's authorized representative shall have the authority to enter all areas covered by such permit at any reasonable hour to enforce the provision of the code(s) applicable to such permit.

SIGNATURE OF APPLICANT	ADDRESS	DATE	PHONE
RESPONSIBLE PERSON IN CHARGE OF WORK, TITLE		DATE	PHONE



FILL IN AND SIGN WITH INK

# APPLICATION FOR PERMIT HEATING OR POWER EQUIPMENT

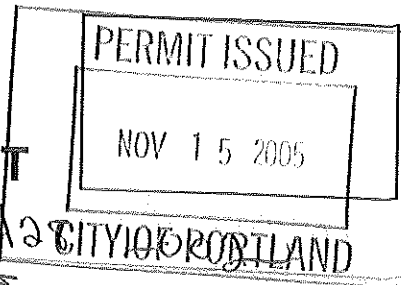

To the INSPECTOR OF BUILDINGS, PORTLAND, ME.

The undersigned hereby applies for a permit to install the following heating, cooking or power equipment in accordance with the Laws of Maine, the Building Code of the City of Portland, and the following specifications:

Location / CBL 18-20 PRESUMPSCOTT ST Use of Building APARTMENT Date 10/26/05  
 Name and address of owner of appliance JIM GIROUX P.O. BOX 11082  
PORTLAND, MAINE  
 Installer's name and address CHRIS O'DONNELL CARON & WALTZ  
321 LINCOLN ST. SOUTH PORTLAND ME Telephone 207-799-2228

### Location of appliance:

- Basement  Floor  
 Attic  Roof

### Type of Fuel:

- Gas  Oil  Solid

Appliance Name: SMITH 8W4T BOILER

U.L. Approved  Yes  No

Will appliance be installed in accordance with the manufacture's installation instructions?  Yes  No

IF NO Explain: \_\_\_\_\_

### The Type of License of Installer:

- Master Plumber # \_\_\_\_\_  
 Solid Fuel # \_\_\_\_\_  
 Oil # MS 2000 5690  
 Gas # \_\_\_\_\_  
 Other \_\_\_\_\_

### Type of Chimney:

Masonry Lined  
Factory built \_\_\_\_\_

Metal  
Factory Built U.L. Listing # \_\_\_\_\_

Direct Vent  
Type \_\_\_\_\_

### Type of Fuel Tank

- Oil  
 Gas

Size of Tank 275

Number of Tanks 1

Distance from Tank to Center of Flame 15' feet.

Cost of Work: \$ 5,425

Permit Fee: \$ 7510

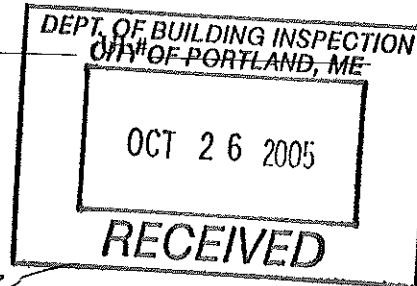

Approved

Approved with Conditions

Fire: \_\_\_\_\_

Ele.: \_\_\_\_\_

Bldg.: \_\_\_\_\_

See attached letter or requirement

Inspector's Signature \_\_\_\_\_

Date Approved \_\_\_\_\_

Signature of Installer \_\_\_\_\_

**City of Portland, Maine - Building or Use Permit**

389 Congress Street, 04101 Tel: (207) 874-8703, Fax: (207) 874-8716

Permit No: 05-1590	Date Applied For: 10/26/2005	CBL: 428 L002001
-----------------------	---------------------------------	---------------------

Location of Construction: 20 PRESUMPCOT ST	Owner Name: GIROUX JAMES R	Owner Address: PO BOX 11082	Phone:
Business Name:	Contractor Name: Caron & Waltz	Contractor Address: 321 Lincoln Street South Portland	Phone (207) 799-2228
Lessee/Buyer's Name	Phone:	Permit Type: HVAC	

Proposed Use: Residential 3 unit / install a Smith 8W4T replacement boiler in basement	Proposed Project Description: ninstall a Smith 8W4T replacement boiler in basement
---	---

Dept: Zoning Note:	Status: Approved	Reviewer: Jeanine Bourke	Approval Date: 11/14/2005 Ok to Issue: <input checked="" type="checkbox"/>
Dept: Building Note:	Status: Approved	Reviewer: Jeanine Bourke	Approval Date: 11/14/2005 Ok to Issue: <input type="checkbox"/>
Dept: Fire Note:	Status: Approved	Reviewer: Jay Kelley	Approval Date: 10/28/2005 Ok to Issue: <input checked="" type="checkbox"/>

# 8 SERIES

## BOILER-BURNER UNIT

STEAM OR HOT WATER

### INSTALLATION AND OPERATING INSTRUCTIONS

DESIGNED AND TESTED ACCORDING TO THE A.S.M.E. BOILER AND PRESSURE VESSEL CODE, SECTION IV FOR MAXIMUM ALLOWABLE WORKING PRESSURE: STEAM 15 LBS. - WATER 40 LBS.



Boiler Model Number	DOE Heating Capacity MBH	I=B=R Burner Capacity Oil Input		I=B=R Net Ratings			Natural Draft Chimney	Relief Valve Capacity Lbs/Hr
		GPH	MBH	Steam		Water MBH		
				SQ. FT.	MBH			
8-*-3L	91	.75	105	283	68	79	8" x 8" x 18'	122
8-*-3H	113	.95	133	350	84	98		
8-*-4L	133	1.10	154	414	99	116	8" x 8" x 17'	176
8-*-4H	150	1.25	175	466	112	130		
8-*-5L	169	1.40	196	525	126	147	8" x 8" x 16'	230
8-*-5H	203	1.70	238	632	152	177		
8-*-6L	211	1.75	245	654	157	183	8" x 8" x 15'	283
8-*-6H	249	2.10	294	776	186	217		

\* Insert "S" for Steam or "W" for Water. The ratings are based on a allowance of 1.333 for steam or 1.15 for water. The manufacturer should be consulted before selecting a boiler for installations having unusual piping and pickup requirements, such as, intermittent system operation, extensive piping systems, etc.

**CAUTION - DO NOT USE AUTOMOTIVE ANTI-FREEZE IN BOILER WATERWAYS. IF NECESSARY TO USE ANTI-FREEZE, BE SURE TO EMPLOY A PREPARATION DESIGNED FOR HYDRONIC HEATING SYSTEMS SUCH AS ETHYLENE OR PROPYLENE GLYCOL.**

THESE INSTRUCTIONS TO BE KEPT WITH THE BOILER FOR REFERENCE PURPOSES.

**Smith**  
CAST IRON BOILERS

WESTCAST, INC.  
260 NORTH ELM STREET WESTFIELD, MA 01085  
TEL. (413) 562-9631 FAX (413) 562-3799



## 8 SERIES BOILER INSTALLATION AND OPERATING INSTRUCTIONS

Figure No. 1 – Boiler Assembly

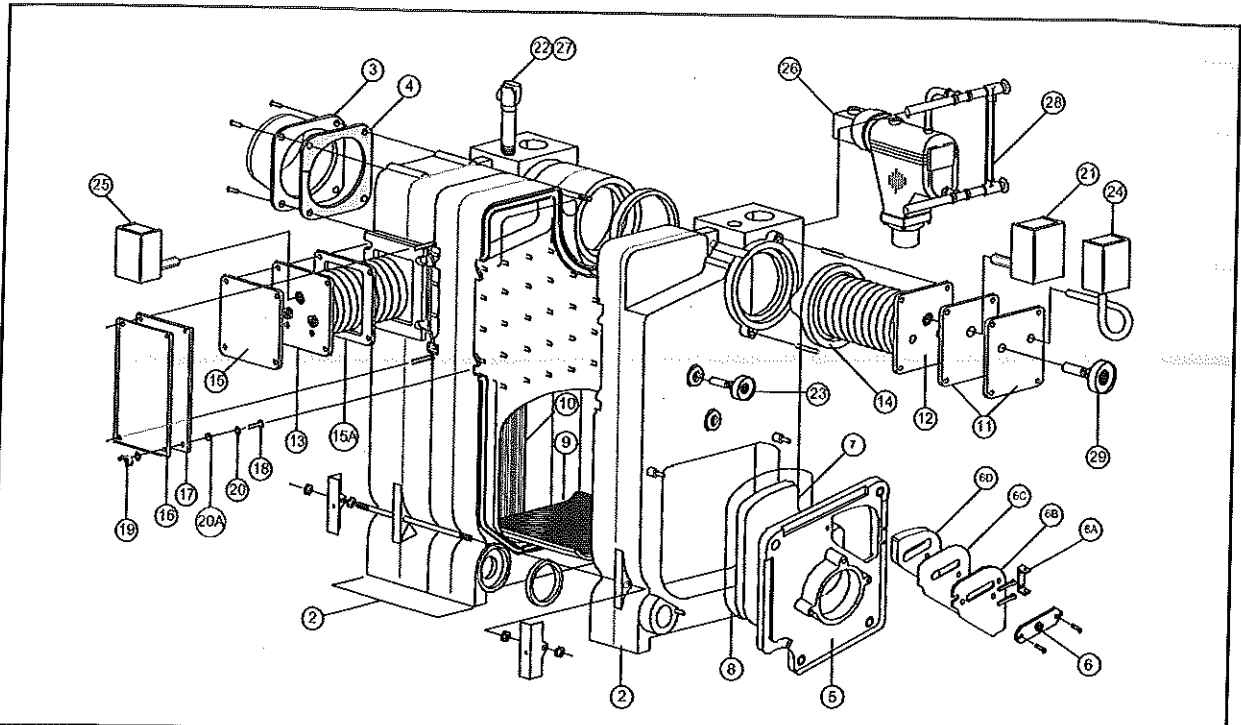

### PARTS LIST

Ref No.	Part No.	Description	Ref No.	Part No.	Description		
1	70251	Complete Jacket - 3 Section	13	70011	Tankless Heater (Steam 3.5 GPM)		
	70252	4 Section		14	60248	Heater Plate Gasket (Water)	
	70253	5 Section		15	69778	Heater Plate (Steam Back)	
	70254	6 Section		15A	60336	Heater Plate Gasket (Steam Back)	
	2	70272		Universal Block - 3 Section	16	55458	Cleanout Cover Plate 14 X 8
		70273		4 Section	17	55459	Cleanout Cover Plate 14 x 12 1/2
70274		5 Section	17	65131	Cleanout Cover Plate Insulation		
3	70275	6 Section		65132			
	71255	Smokehood 6" (3 & 4 Section)	18	60020	Cleanout Bolt (5/16)		
4	71393	Smokehood 7" (5 & 6 Section)	19	60881	Cleanout Nut (5/16)		
	60334	Smokehood Gasket	20	62095	Cleanout Washers (5/16)		
5	71257	Burner Mounting Plate	Water Controls & Trim				
6	3383	Observation Cover Plate	21	50523	Aquastat L8148A (less tankless)		
6A	61135	Cleanout Door Hinge		50501	Aquastat L8124A (w/ tankless)		
6B	3665	Cleanout Door	22	61988	Relief Valve 30# (water)		
6C	61136	Cleanout Door Gasket	23	60265	Temp & Pressure Gauge		
6D	61138	Cleanout door Insulation	Steam Controls & Trim				
7	61137	Insulation Block	24	50493	Steam Pressuretrol PA404A		
8	60023	Wicking 1/4" (4 ft. req'd)	25	50510	Tankless Ctrl. L4007A (steam)		
9	74310	Floor Insulation Blanket - 3 Section	26	50763	67 L.W.C.O (steam)		
	74311	4 Section	27	61980	Relief Valve 15# (steam)		
	74312	5 Section	28	60289	Gauge Glass Set		
	74313	6 Section	29	60268	Steam Gauge		
10	69406	Target Wall					
11	3579	Heater Cover Plate (Steam)					
	3667	Heater Cover Plate (Water)					
12	70009	Tankless Heater Water (3.5 GPM)					
	70010	Tankless Heater Water (5.0 GPM)					

# 8 SERIES BOILER

## INSTALLATION AND OPERATING INSTRUCTIONS

### 1. GENERAL

The 8 Series boiler-burner unit is a wet-base, vertical flue, low pressure, sectional, cast iron steam or hot water heating boiler. It is rated for natural draft firing with 0.02 ins. water column over-fire draft. Boilers are available as either factory assembled in blocks from three to six sections in length with burner and controls supplied for field assembly or as a completely packaged boiler.

The ports between sections are provided with a special hydronic seal which is resistant to petroleum products. The flue gas seal between sections is accomplished by the use of fiberglass rope rated at 1000° F.

Both packaged units and assembled blocks of sections are hydrostatically tested for the maximum working pressures. The assembled blocks also include the special hydronic seals, the glass fiber rope joint seal, a precast fiber target wall, the insulated burner mounting plate and cleanout covers.

An insulated metal jacket is furnished to both enhance the units looks and to minimize any heat loss. A full access cleanout cover for cleaning vertical flue passages is on the left hand side of the boiler and is accessible by removing the left hand cleanout access jacket panel.

**IMPORTANT - Sufficient clearance between the left side of the boiler and adjacent construction must be provided to ensure proper access when cleaning is required!**

### 2. CODES, RULES AND REGULATIONS

The installation of the boiler, the burner, wiring, controls and fuel piping must be done in accordance with the requirements of the local authorities having jurisdiction. In the absence of local requirements, the following codes apply:

ANSI/NFPA31 - "Installation of Oil Burning Equipment"  
ANSI/NFPA70 - "National Electrical Code"

In Canada the following codes apply:

CSA STD. B139 - Latest Edition.

"Installation Code For Oil Burning Equipment."

CSA STD. C22.2 No. 0 - Latest Edition.

"General Requirements - Canadian Electrical Code Part II."

All completed boilers shall satisfactorily pass the hydrostatic tests as prescribed by A.S.M.E., Code Section IV.

1. Steam Boilers – The assembled boiler shall be subjected to a hydrostatic test of not less than 45 psig.
2. Water Boilers – The assembled boiler shall be subjected to a hydrostatic test pressure not less than 1-1/2 times the maximum allowable working pressure.
3. The required test shall not exceed the test pressure by more than 10 psi.

### 3. BOILER LOCATION

Boiler should be located on a smooth level concrete floor or pad close to the chimney to minimize breeching length. Allow access for boiler cleaning and burner maintenance.

**CAUTION - Boiler shall be installed on non-combustible floor only.**

### 4. CHIMNEY AND BREECHING

Attach the smoke hood to the back of the boiler using the 4 brass machine screws making sure to install the gasket between the smoke hood and boiler. The 3 and 4 section models are equipped with a 6" smoke hood, the 5 and 6 section models with a 7" smoke hood. The boiler must be vented with vent pipe having the same diameter as the smoke hood collar. Place the flue pipe over the smoke hood collar and secure it to the collar with a sheet metal screw.

The boiler must be vented to the outdoors by means of a fire lined masonry chimney of the size listed on the front page or by another approved method.

The flue pipe should be run to the chimney by the most direct route, with the minimum number of elbows and with a slight upward pitch. The pipe should terminate flush with the inside face of the chimney and should be sealed in place with insulating cement.

For energy conservation, the boiler should be vented directly to the chimney without using a barometric draft control. The burner operation does not require draft control for stability with varying draft values.

### 5. COMBUSTION AND VENTILATION

Normal residential construction usually allows sufficient air infiltration for combustion. If construction is tight, consideration should be given for air louvers to the outside. Local codes or NFPA 31, "Installation of Oil Burning Equipment", should be referred to for proper sizing and design and air supply. In Canada refer to CSA STD. B139 - latest edition.

**WARNING: This boiler must be connected to a properly sized and constructed chimney or vent system! Failure to comply with this warning can result in a fire which could cause extensive property damage, severe personal injury or death!**

### 6. PACKAGED BOILERS

Packaged boilers are shipped on a wood skid with tie down bands and a wooden crate enclosing the boiler and burner.

Remove the protective crate and skid. Set the boiler in its final location and shim under the feet to make it level and secure. Adjust the jacket for proper alignment and support. Refer to Carlin or Beckett Series 8 Burner Installation Manual for appropriate wiring diagrams.

## 8 SERIES BOILER INSTALLATION AND OPERATING INSTRUCTIONS

### 7. BLOCKS OF SECTIONS

Blocks of sections are arranged for use either as steam or water boilers. All back sections have a flanged opening in the left side, below the water line. A tankless heater may be installed in this location.

**NOTE:** A cover plate is supplied as part of either the steam trim or water trim cartons.

Unlike the packaged units, blocks of sections require that the smokehood, controls, burner, steam or water trim, circulators (water boilers), and jackets must be installed in the field.

The smokehood is sized for a 7 inch diameter flue pipe placed over the cast iron collar and secured to the collar with a sheet metal screw. Place the furnished smokehood gasket in place between the smokehood and the back section, and assemble with hardware furnished.

### 8. PACKAGED BOILERS AND BLOCKS OF SECTIONS

Careful inspection should be made of all assemblies to detect possible damage during shipment. Factory assembled blocks of sections and package boilers are hydrostatically tested at the factory to insure pressure tightness. Before piping connections are made to the boiler, hydrostatically retest boiler sections to detect leaks that may have developed from rough handling during shipment, see Section 2.

### 9. BURNER INSTALLATION

Instructions regarding both assembly and operation of the burner is covered in a separate catalog.

**WARNING:** Never attempt to operate the boiler with the cleanout cover plates removed! Failure to comply with this warning can result in a fire which could cause extensive property damage, severe personal injury or death!

### 10. CLEANOUT COVER PLATES

It is important to maintain the integrity of the gas seal by careful installation of the cleanout cover plate. Be sure there is no opening to allow gases to escape.

### 11. JACKET ASSEMBLY

Remove all knockouts that are going to interfere with your specific installation arrangement. Install the front panel over the two upper burning mounting plate studs prior to the installation of the burner mounting plate. Fold the right side panel at both the front and rear perforated seams 90° back against the insulation. Slide the front fold under the front panel and secure with philip head screw. Lift side panel up slightly to align the slots in jacket with the bracket holes. Secure with the screws supplied.

Repeat same procedure for the left side panel.  
Screw the two folds together at the back of the boiler.

Attach the top panel over the edges of all panels and secure. The cleanout cover door attaches to the left side panel by sliding the lower left corner into the slot provided and up over the fold at the top of the opening in the side panel. Slide the cover back toward the rear of the boiler until it makes contact with the back of the slot.

Figure No. 2 – Jacket Assembly

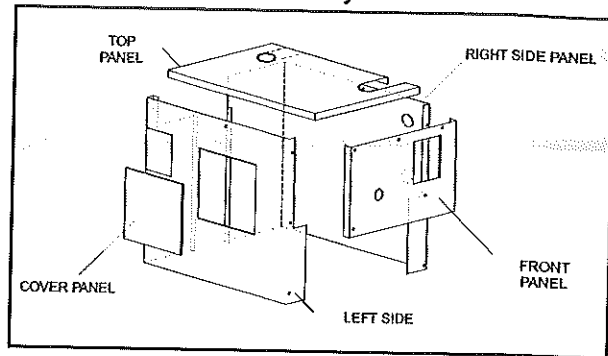

### 12. BOILER TRIM

#### Steam

The steam trim furnished with the boiler consists of a 2-1/2" round steam pressure gauge, McDonnell Miller #67 Quick Hook-Up Low Water Cutoff, water gauge glass set with gauge cocks, side outlet steam safety valve, and high pressure limit control with siphon. Refer to Figure No. 3 for correct control and trim locations. Pipe fittings required to install trim and controls as shown are furnished.

#### Water

The water trim furnished with the boiler consists of a 2-1/2" round temperature altitude gauge and a 30 psi pressure relief valve. A circulator relay is furnished for installation in the upper port cover plate or the tankless heater cover plate as indicated in Figure No. 3. The installer must furnish and install air removal devices, expansion tank, automatic air vents, make-up water pressure reducing valve, isolating valves and other pipe fittings and equipment necessary for proper operating system.

Install safety or relief valve in top 3/4" tapping of back section.

**WARNING:** Never install any type of valve between the pressure relief or safety valves and the boiler! Failure to comply with this warning can result in a boiler explosion causing extensive property damage, severe personal injury or death!

**WARNING:** The pressure relief or safety valve discharge piping must direct all water and vapor away from personnel. Failure to comply with this warning could result in severe personal injury!

# 8 SERIES BOILER INSTALLATION AND OPERATING INSTRUCTIONS

Figure No. 3 – Boiler Trim

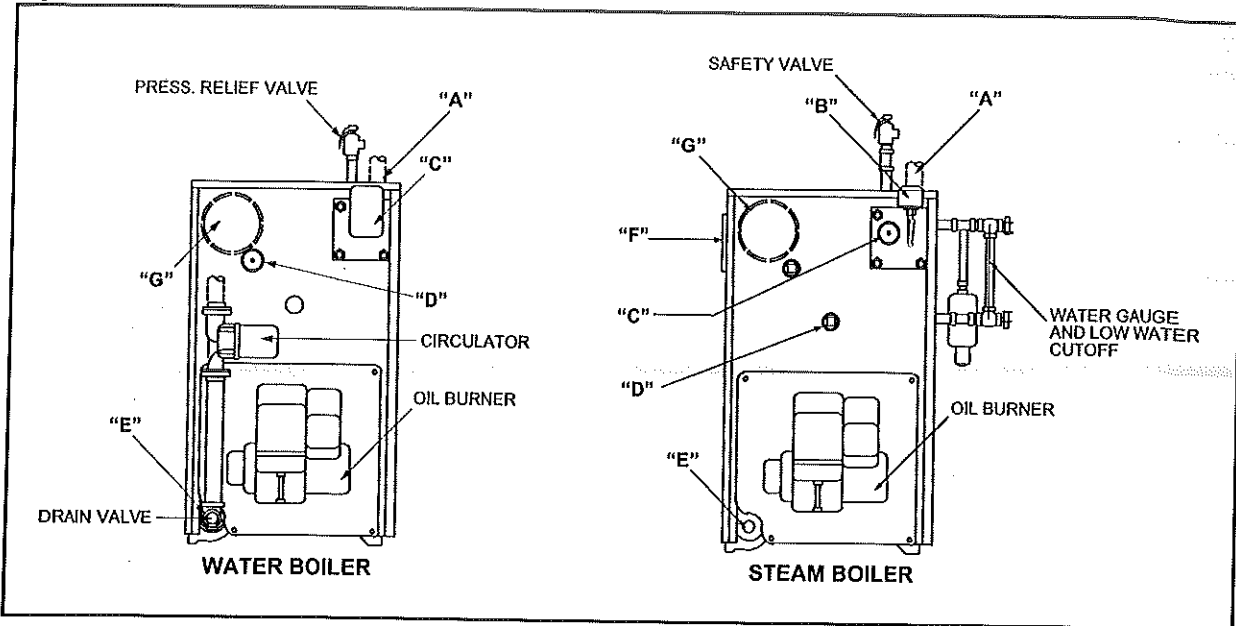

LOCATION	SIZE	WATER	STEAM
"A"	2"	Supply	Supply
"B"	1/4"	.....	High Pressure Limit
"C"	3/4"	Hydronic Relay	.....
	1/4"	.....	Press. Gauge
"D"	1"	Temperature/Pressure Gauge	Tapping for Indirect Hot Water Heater
"E"	1 1/4"	Return (Front) With Drain	.....
	1 1/2"	.....	Return (Back) With Drain
"F"	Flange	.....	Tankless Heater (Locate temp. control in domestic coil mtg. plate.)
"G"	6"	Flue Vent Conn. (Back) 3 & 4 Section	Flue Vent Conn. (Back) 3 & 4 Section
	7"	Flue Vent Conn. (Back) 5 & 6 Section	Flue Vent Conn. (Back) 5 & 6 Section

### 13. OPERATING AND LIMIT CONTROLS

Many jurisdictions require dual limit controls. The boiler installer must arrange to comply with local requirements by furnishing and installing any extra controls. The suggested locations for such controls are indicated on Figure No. 3.

The water boiler without tankless water heater is furnished with a Honeywell L8148A hydronic relay, which, provides high limit and circulator switching upon signal from a 24 volt operating control. The water boiler with tankless is furnished with a Honeywell L8124A hydronic relay, which provides high limit, low limit and reverse action circulator control under signal from a 24 volt operating control.

The steam boiler is furnished with a high limit pressure control and low water cutoff. If tankless hot water is furnished, a low limit temperature control is shipped loose and must be piped and wired. Recommended wiring diagrams for these boilers are illustrated in the separate burner instruction catalog.

### 14. PIPING CONNECTIONS

The recommended boiler piping connections are shown in Figure. No. 4. Where special conditions exist, other arrangements may be employed.

**IMPORTANT - Steam piping should be pitched to insure both steam and condensate flow back toward drip leg.**



Figure No. 4 – Piping Connections

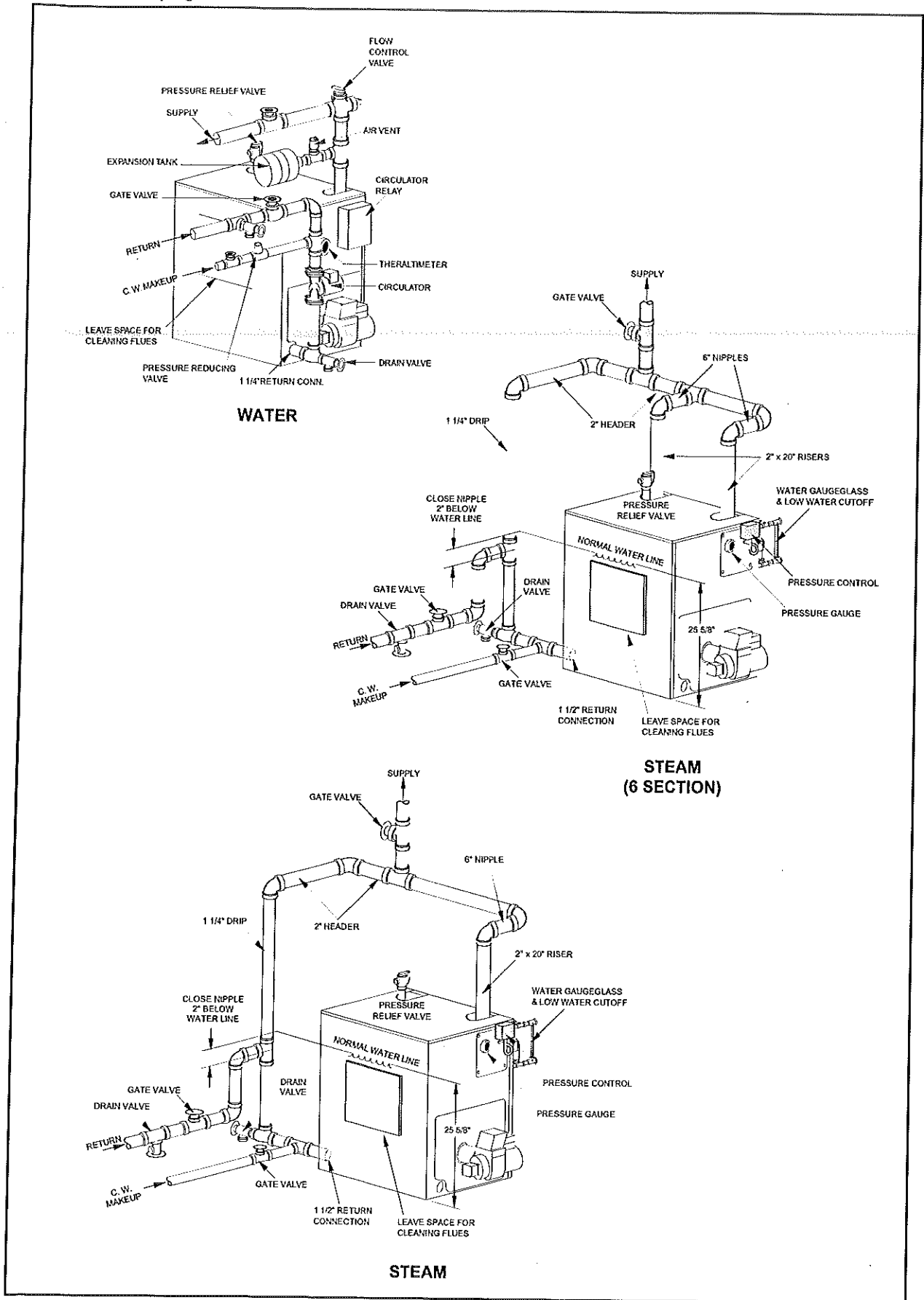

# 8 SERIES BOILER INSTALLATION AND OPERATING INSTRUCTIONS

## 15. CIRCULATORS

The Taco 007 and 0010 circulators are suitable for use on a closed heating system with 30 psi maximum operating pressure. If the circulator furnished with the boiler does not have the required capacity to serve the connected load, provide an extra zone circulator (Figure No. 5) or change the circulator to the proper size. Capacity curves for the circulators are provided in these instructions to permit the sizes to be checked with the system requirements. See Figure No. 10 & 11.

**NOTE:** The Taco 0010 circulator is rated for 125 psi maximum operating pressure.

Figure No. 5 – Zone Circulators

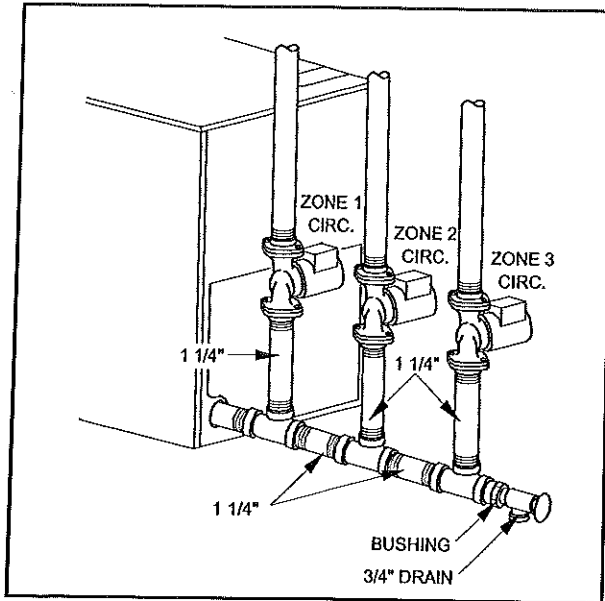

**CAUTION**

To prevent damage due to excessive condensation, one of the following piping options should be used.

**System Bypass**

For systems using a circulator on the return as either a single zone, or multiple zones with zone valves, install a system bypass line between the supply and return on the suction side of the circulator, see Figure 6. Install a metering valve in this bypass line to regulate the amount of flow that will be diverted to the return. A plug valve offers the best control for this application. Although other valves may be less expensive, a plug valve will be easier to set accurately.

In the absence of a flow indicator, set the metering valve using temperature as a guide. The accompanying diagram suggests one scenario. This addition requires only two tees, a plug valve, and a small amount of pipe and offers the simplest approach to reliably control condensation. For this system and those that follow, be aware that you are using a percentage of the pump capacity to blend, but the friction loss for the entire pump flow has been reduced. In most cases, the standard pump packaged with the boiler has enough capacity to feed the baseboard distribution system and the bypass line.

Figure 6 – System Bypass

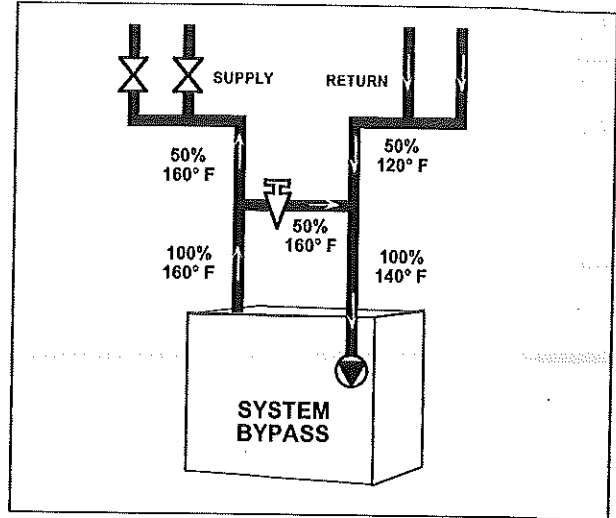

**Pump Away Bypass**

For systems that use a single circulator to pump away from the boiler, the bypass should be installed on the discharge side of the circulator, see Figure 7. Full temperature water supplies the baseboard distribution system as before. Half of the circulator's volume moves through the bypass, blending and heating the cooler return water. Again, the cost of installing the bypass is small and setting it by temperature can be accomplished with a contact thermometer.

Figure No. 7 – Pump Away Bypass

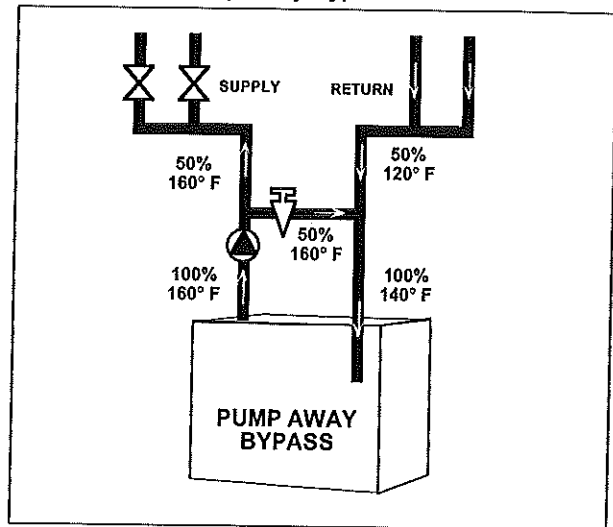

## 8 SERIES BOILER INSTALLATION AND OPERATING INSTRUCTIONS

### Pumped Blend

An additional circulator can also be used to provide a return water temperature blend. This method works well with systems with multiple zones with circulators, see Figure 8. The dedicated bypass circulator provides a strong blending flow without diminishing the flow available to any heating zone. Any residentially sized circulator is adequate for this purpose.

Each of these bypass solutions also has the added benefit of increasing circulation in the boiler which will maximize tankless coil output and increase the accuracy of temperature sensing controls.

Figure No. 8 – Pumped Bypass

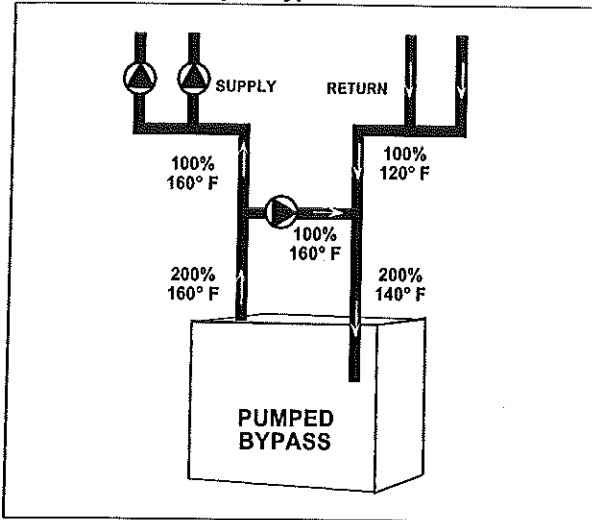

### Reverse Acting Aquastats

An alternative for existing systems experiencing condensation that does not require re-piping the boiler utilizes a reverse acting aquastat, one that makes on temperature rise. This approach works best in single zone systems. Wired in series with the circulator, this control holds the circulator off until the boiler reaches an acceptable temperature and then starts system circulation, see Figure 9.

The most commonly available reverse acting aquastat is a Honeywell L4006B. The aquastat should be mounted in an immersion well directly installed in the boiler. The use of heat conductive grease, Honeywell part #972545, in the immersion well is strongly recommended for fast and accurate temperature response. Set this adjustable aquastat to make at no less than 130°F. While this method can cause the circulator to cycle more frequently, setting the aquastat's differential to the maximum 25-30°F will minimize short cycling.

Figure No. 9 – Reverse Aquastat

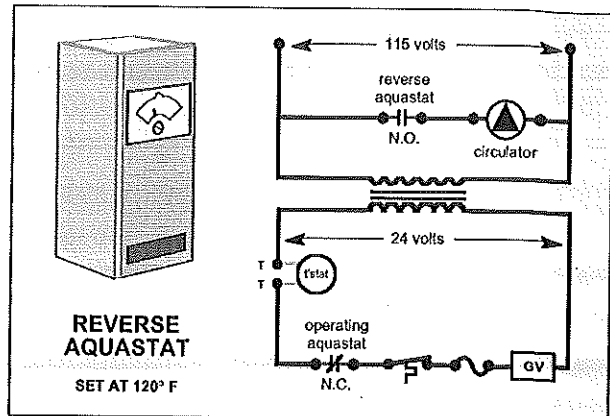

### 16. DOMESTIC HOT WATER HEATERS

Tankless domestic hot water heaters are available for either water boiler or steam boiler application. Refer to Page 2 for correct installation of tankless heaters. Table 1 and 2 list water capacities for both styles of heaters. See Figure No. 12 for suggested tankless water heater piping arrangement.

### 17. FILLING THE SYSTEM

#### Water

Fill the system slowly, venting and checking for leaks. Do not operate the circulator until the system is full.

When the relief valve is set to operate at 30 psi, the initial fill pressure should be sufficient to fill the system to the high point and develop a pressure at that point so as to prevent the water in the system from boiling at the maximum operating temperature. Under normal conditions, a static height of 18-1/2 feet will require an initial fill pressure of 12 psi.

#### Steam

Stable water level is a necessity for steam boilers. It is very important to have boiler water free from oil, grease, foaming materials etc. Therefore, flush the boiler thoroughly through a bottom drain by introducing clean water into the upper ports of all sections of the boiler. After the boiler piping connections are completed and the boiler can be fired, the boiler water should be heated up and surface impurities flushed off through a high connection (1-1/4" tapping provided in heater cover plate) and then drained through a bottom opening. The burner should not be operated with low water level in the boiler and makeup water should not be introduced into a hot boiler.

If possible, the heating boiler should be operated for a time with all condensate returning from the system being wasted to a drain. This will remove impurities from the piping system which, if not removed early, will eventually enter the boiler and cause problems. In some instances, more than one cleaning will be required to obtain stable water line.

# 8 SERIES BOILER INSTALLATION AND OPERATING INSTRUCTIONS

Figure No. 10 – Head-Feet of Water

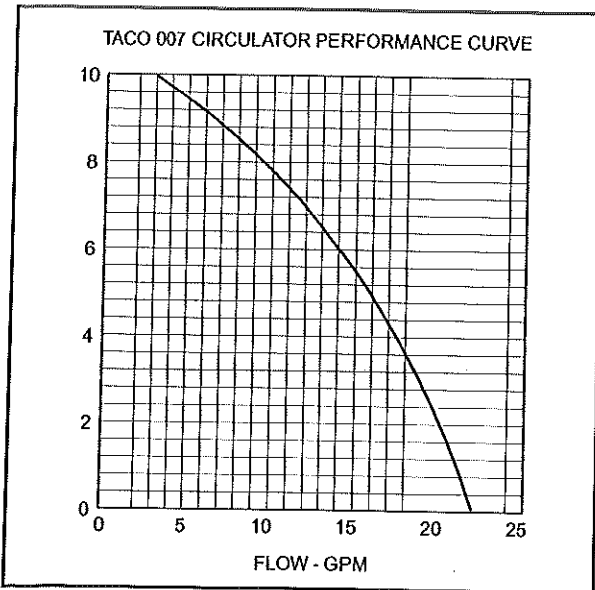

Figure No. 11 – Head-Feet of Water

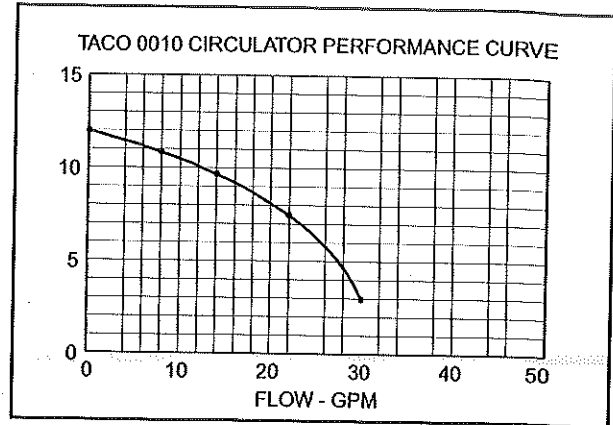

Figure No. 12 – Tankless Heater

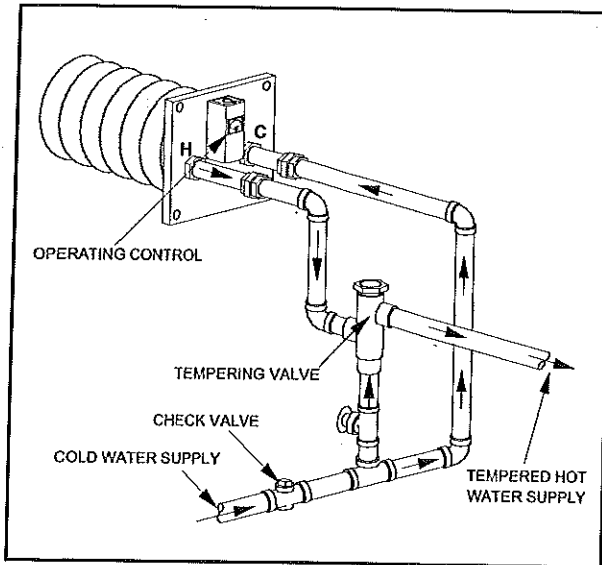

Figure No. 13 – Safety/Relief Valve Installation

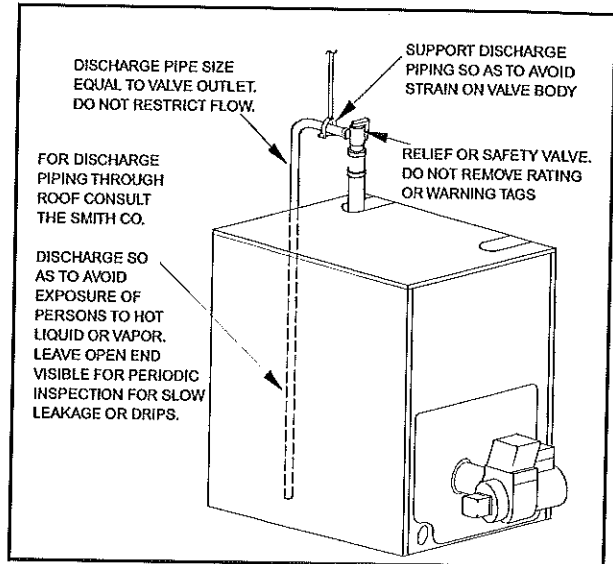

Table 1

DOMESTIC HOT WATER SUPPLY STEAM BOILER			
No. of Sections	Firing Rate	Intermittent Draw (GPM)	Continuous Draw (GPM)
3	Low	2.50	1.75
	High	2.50	2.00
4	Low	3.30	2.50
	High	3.50	2.90
5	Low	3.50	3.30
	High	3.50	3.50
6	Low	3.50	3.50
	High	3.50	3.50

Table 2

DOMESTIC HOT WATER SUPPLY WATER BOILER			
No. of Sections	Firing Rate	Intermittent Draw (GPM)	Continuous Draw (GPM)
3	Low	2.50	1.75
	High	2.50	2.00
4	Low	3.30	2.50
	High	3.30	2.90
5	Low	3.80	3.30
	High	4.50	3.90
6	Low	4.60	4.00
	High	5.00	4.90

40° to 140° temp. rise at 180° F. boiler water.

# 8 SERIES BOILER INSTALLATION AND OPERATING INSTRUCTIONS

Figure No. 14 – Steam Wiring Cables

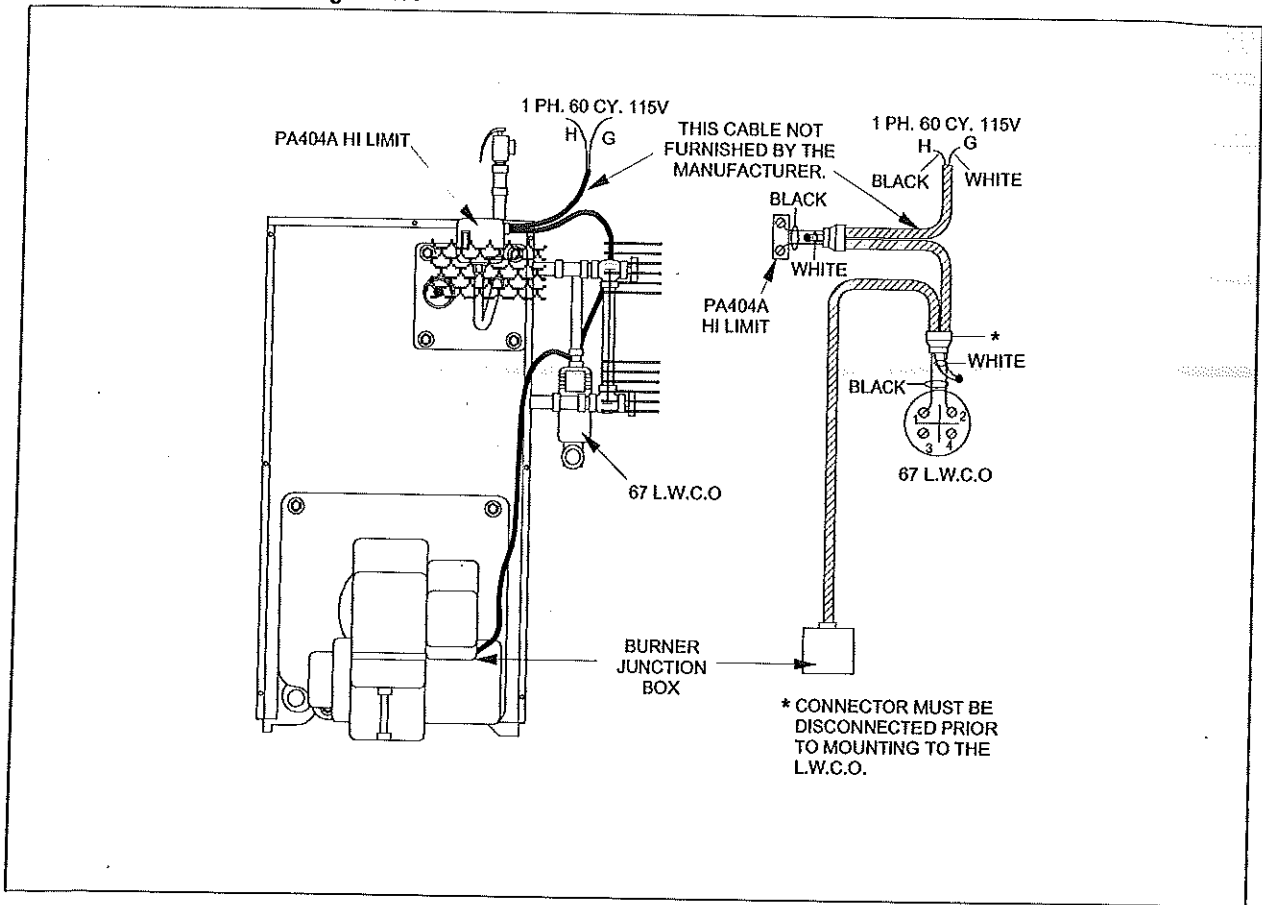

## WARNING

Any appliance that burns natural gas, propane gas, fuel oil, wood or coal is capable of producing carbon monoxide (CO).

Carbon Monoxide (CO) is a gas which is odorless, colorless and tasteless but is very toxic.

If your Smith boiler is not working properly, or is not vented properly, dangerous levels of CO may accumulate. CO is lighter than air and thus may travel throughout the building. **BRIEF EXPOSURE TO HIGH CONCENTRATIONS OF CO, OR PROLONGED EXPOSURE TO LESSER AMOUNTS OF CO MAY RESULT IN CARBON MONOXIDE POISONING.**

**EXPOSURE CAN BE FATAL AND EXPOSURE TO HIGH CONCENTRATIONS MAY RESULT IN THE SUDDEN ONSET OF SYMPTOMS INCLUDING UNCONSCIOUSNESS.**

Symptoms of CO poisoning include the following:

dizziness	vision problems	shortness of breath
headaches	loss of muscle control	unclear thinking
nausea	weakness	unconsciousness

The symptoms of CO poisoning are often confused with those of influenza, and the highest incidence of poisoning occurs at the onset of cold weather or during flu season. A victim may not experience any symptoms, only one symptom, or a few symptoms. Suspect the presence of carbon monoxide if symptoms tend to disappear when you leave your home.

The following signs may indicate the presence of carbon monoxide:

- Hot gases from appliance, venting system, pipes or chimney, escaping into the living space.
- Flames coming out around the appliance.
- Yellow colored flames in the appliance.
- Stale or smelly air.
- The presence of soot or carbon in or around the appliance.
- Very high unexplained humidity inside the building.

If any of the symptoms of CO poisoning occur, or if any of the signs of carbon monoxide are present, **VACATE THE PREMISES IMMEDIATELY AND CONTACT A QUALIFIED HEATING SERVICE COMPANY OR THE GAS COMPANY OR THE FIRE DEPARTMENT.**

To reduce the risk of CO poisoning, have your heating system "tuned up" by a licensed heating contractor or the gas company - preferably before each heating season. Also have the service company check your chimney or vent pipes for blockage.

Your home should also be adequately ventilated, particularly if you have insulated your home.

**ONLY QUALIFIED, LICENSED SERVICE CONTRACTORS SHOULD PERFORM WORK ON YOUR SMITH BOILER!**

## WARNING

Install, operate and maintain unit in accordance with manufacturer's instructions to avoid exposure to fuel substances or substances from incomplete combustion which can cause death or serious illness. The State of California has determined that these substances may cause cancer, birth defects, or other reproductive harm. Also, install and service this product to avoid exposure to airborne particles of glasswool fibers and/or ceramic fibers known to the State of California to cause cancer through inhalation.

**Smith**  
CAST IRON BOILERS

WESTCAST, INC.  
260 NORTH ELM STREET WESTFIELD, MA 01085  
TEL. (413) 562-9631 FAX (413) 562-3799