

City of Portland, Maine - Building or Use Permit Application
 389 Congress Street, 04101 Tel: (207) 874-8703, Fax: (207) 874-8716

Permit No: 06-1218	Issue Date: JANUARY 30 2007	CBL: F009001
-----------------------	--------------------------------	-----------------

Location of Construction: 40 ARCADIA ST	Owner Name: CORMIER JEFFREY S	Owner Address: 40 ARCADIA ST	Phone: 9002 8 2 500
Business Name:	Contractor Name: Dominic DiBiase	Contractor Address: 52 Constitution Drive Westbrook	Phone: 2077975408
Lessee/Buyer's Name	Phone:	Permit Type: HVAC	Zone: G1SS1MRE3

Past Use: Duplex	Proposed Use: Duplex- install a direct vent rimaai on the 1st flr & Second Flr	Permit Fee: \$60.00	Cost of Work: \$3,700.00	CEO District: 4
Proposed Project Description: install a direct vent rimaai on the 1st flr & Second Flr		FIRE DEPT: <input checked="" type="checkbox"/> Approved <input type="checkbox"/> Denied	INSPECTION: Use Group: <i>HVAC</i> Type: <i>8/23/06</i>	

Permit Taken By: Idobson	Date Applied For: 08/18/2006	Signature: <i>Greg Cass</i>	Signature: <i>Greg Cass</i>	Date: 8/23/06
1. This permit application does not preclude the Applicant(s) from meeting applicable State and Federal Rules.		Action: <input type="checkbox"/> Approved <input type="checkbox"/> Approved w/Conditions <input type="checkbox"/> Denied	Date:	

Zoning Approval

Special Zone or Reviews	Zoning Appeal	Historic Preservation
<input type="checkbox"/> Shoreland <input type="checkbox"/> Wetland <input type="checkbox"/> Flood Zone <input type="checkbox"/> Subdivision <input type="checkbox"/> Site Plan Maj <input type="checkbox"/> Minor <input type="checkbox"/> MM <input type="checkbox"/>	<input type="checkbox"/> Variance <input type="checkbox"/> Miscellaneous <input type="checkbox"/> Conditional Use <input type="checkbox"/> Interpretation <input type="checkbox"/> Approved <input type="checkbox"/> Denied	<input type="checkbox"/> Not in District or Landmark <input type="checkbox"/> Does Not Require Review <input type="checkbox"/> Requires Review <input type="checkbox"/> Approved <input type="checkbox"/> Approved w/Conditions <input type="checkbox"/> Denied
Date:	Date:	Date:

CERTIFICATION

I hereby certify that I am the owner of record of the named property, or that the proposed work is authorized by the owner of record and that I have been authorized by the owner to make this application as his authorized agent and I agree to conform to all applicable laws of this jurisdiction. In addition, if a permit for work described in the application is issued, I certify that the code official's authorized representative shall have the authority to enter all areas covered by such permit at any reasonable hour to enforce the provision of the code(s) applicable to such permit.

SIGNATURE OF APPLICANT _____ ADDRESS _____ DATE _____ PHONE _____

RESPONSIBLE PERSON IN CHARGE OF WORK TITLE _____ DATE _____ PHONE _____



APPLICATION FOR PERMIT HEATING OR POWER EQUIPMENT

FILL IN AND SIGN WITH INK

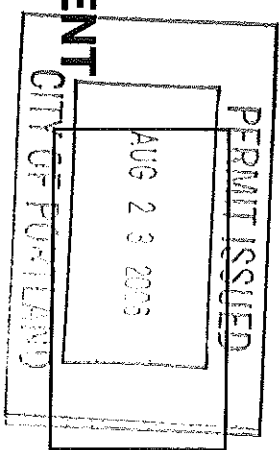

To the INSPECTOR OF BUILDINGS, PORTLAND, ME.

The undersigned hereby applies for a permit to install the following heating, cooking or power equipment in accordance with the Laws of Maine, the Building Code of the City of Portland, and the following specifications:

Location / CBL 40 Acadia St. 427-F.9 Use of Building Dwelling Date 8-18-08
Name and address of owner of appliance Adem Hill 40 Acadia St. Portland, Me.

Installer's name and address Dominic DiBisce
52 Constitution Dr. Telephone 797-5408
Westbrook, Me. 04092

Location of appliance:
 Basement Floor 1st & 2nd
 Attic Roof

Type of Fuel:
 Gas Oil Solid
 Gas Oil Solid

Appliance Name: Rinnai
U.L. Approved Yes No

Will appliance be installed in accordance with the manufacturer's installation instructions? Yes No

IF NO Explain: P

The Type of License of Installer:
 Master Plumber # _____
 Solid Fuel # _____
 Oil # _____
 Gas # PNT1253
 Other _____

Approved

See attached letter or requirement

Approved with Conditions

Fire: _____
Ele.: _____
Bldg.: _____
Signature of Installer: _____
Inspector's Signature: _____ Date Approved: _____

Type of Chimney:
 Masonry Lined
Factory built _____
 Metal
Factory Built U.L. Listing # _____
 Direct Vent
Type External U.L.# _____
Double Wall
Type of Fuel Tank
 Oil
 Gas

Size of Tank _____
Number of Tanks _____
Distance from Tank to Center of Flame _____ feet
Cost of Work: \$ 3766.00
Permit Fee: \$ 60

White - Inspection

Yellow - File

Pink - Applicant's

Gold - Assessor's Copy

City of Portland, Maine - Building or Use Permit

389 Congress Street, 04101 Tel: (207) 874-8703, Fax: (207) 874-8716

Permit No:	06-1218	Date Applied For:	08/18/2006	CBL:	427 F009001
------------	---------	-------------------	------------	------	-------------

Location of Construction:	40 ARCADIA ST	Owner Name:	CORMIER JEFFREY S	Owner Address:	40 ARCADIA ST	Phone:	
Business Name:		Contractor Name:	Dominic DiBiase	Contractor Address:	52 Constitution Drive Westbrook	Phone:	(207) 797-5408
Lessee/Buyer's Name		Phone:		Permit Type:	HVAC		

Proposed Use:	Duplex- install a direct vent rinnai on the 1st flr & Second Flr	Proposed Project Description:	install a direct vent rinnai on the 1st flr & Second Flr
---------------	--	-------------------------------	--

Dept: Building Status: Approved with Conditions Reviewer: Mike Nugent Approval Date: 08/23/2006
 Note: 1) The installation must comply with the State of Maine Gas Regulations. Ok to Issue:

Dept: Fire Status: Approved Reviewer: Cptm Greg Cass Approval Date: 08/22/2006
 Note: Ok to Issue:

Rinnai

RHFE-1004FA

ENERGYSAVER

Direct Vent Wall Furnace

Rinnai model number:

Natural Gas RHFE-1004FA-N Propane RHFE-1004FA-P

Gas Rate (Input):

	Btu/hr	Btu/hr
Low:	10,500	10,500
High:	38,400	36,500

Gas Rate (Output):

Low:	8,400	8,400
High:	30,700	29,200

Efficiency Rating:

	80.8%	81.8%
--	-------	-------

Gas Supply Pressure:

	WC	WC
Min:	5"	11.0"
Max:	10.5"	13.0"

Description:

Fan forced flue gas furnace

Connections:

Electrical - AC 120V 60Hz 47 watts
Gas - 1/2" FNPT

Combustion System:

Stainless steel Bunsen burner

Ignition System:

Continuous spark

Operating Buttons:

ON/OFF, Up/Down, Function-lock, Economy

Economy Mode:

Energy savings feature

Humidifier Tray:

Capacity - 7 pints (3000cc)

Weight:

Approx. 90 lbs

Clearance from Combustibles:

Side: 2"
Top: 10"
Front: 40"

Dimensions:

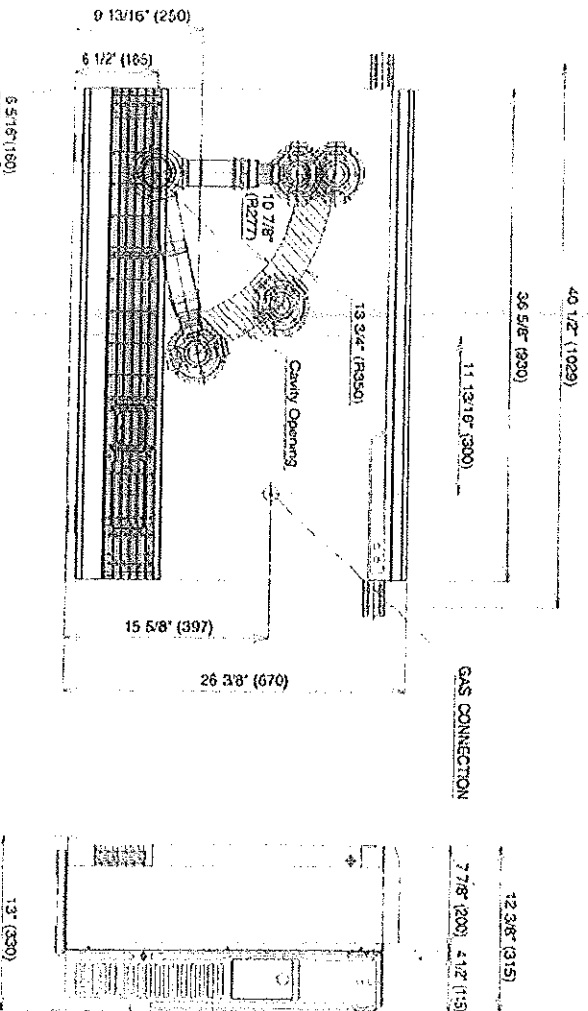

Rinnai
RHFE-1004FA

www.rinnai.us

RHFE-1004FA

Warm Air Outlet:
Fan CFM Output:

Operation:

Temperature Control:

Temperature Range:

Safety Devices:

Bottom front louvers

Low: 203.4

High: 360.6

Finger touch control buttons

Electronic thermostat HI-LOW/OFF, Up/Down switch 2°F increments

LOW=55°F 60°F~80°F HI=High Combustion

Flame failure – flame rod

Over heat – Bi-metal switch, thermal fuse, thermistor

Power failure - PCB

Power surge – 5 Amp fuse

Fan delay – Micro computer timer

Pre-purge – Combustion fan, pre-purge timer, spark sensor

Room over heat – Automatic cut off at 104°F after 10 minutes

Child Safety Lock

Control Panel:

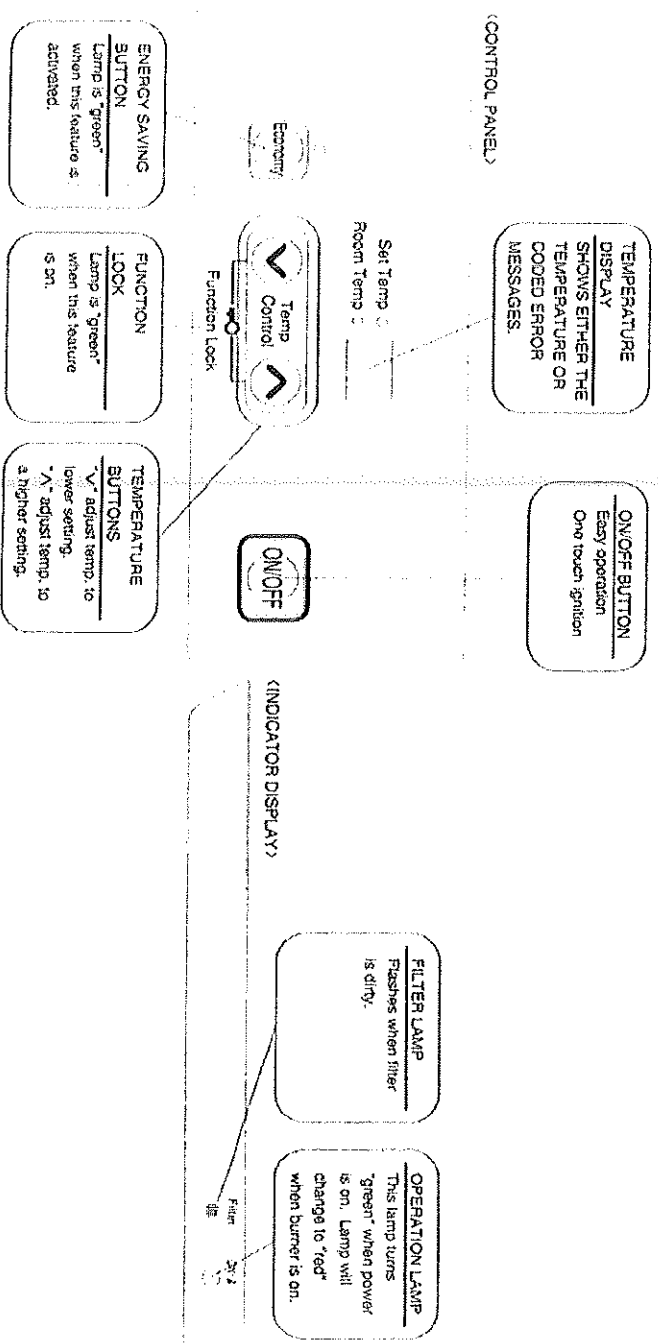

GAS CONNECTION

1. The gas supply line shall be gas-tight, sized and so installed as to provide a supply of gas sufficient to meet the maximum demand of the heater without loss of pressure.
2. A shut off valve (and appliance connector valve) should be installed in the upstream of the gas line to permit servicing.
3. Flexible pipe and any appliance connector valve used for gas piping shall be types approved by nationally recognized agencies.
4. Any compound used on the threaded joint of the gas piping shall be a type which resists the action of liquefied petroleum gas.
5. Supplied gas pressure must be within the limits shown in the specifications.

6. After completion of gas pipe connections, all joints including the heater must be checked for gas tightness by means of leak detector solution, soap and water, or an equivalent nonflammable solution, as applicable.

CAUTION: Since some leak test solutions, including soap and water, may cause corrosion or stress cracking, the piping shall be rinsed with water after testing, unless it has been determined that the leak test solution is noncorrosive.

7. The appliance and its appliance main gas valve must be disconnected from the gas supply piping system during any pressure testing of that system at test pressures in excess of 1/2 P.S.I. (3.5kPa).

The appliance must be isolated from the gas supply piping system by closing its individual manual shut off valve during any pressure testing of the gas supply system at test pressures equal to or less than 1/2 psig.

8. One 1/8" test plug is provided for testing of manifold pressure see schematic for location. (On page 43, item # 125)
At time of installation installer must supply a 1/8" N.P.T. plugged tapping, accessible for test manometer connection, immediately up stream of the gas supply connection to the appliance.

CANADIAN VENT REGULATIONS

CAN/CGA-B149.1-M91

A vent shall not terminate:

- (a) Directly above a paved sidewalk or paved driveway which is located between two single family dwellings and serves both dwellings;
- (b) less than 7 ft. (2.13m) above a paved sidewalk or a paved driveway located on public property;
- (c) within 6 ft. (1.8m) of a mechanical air supply inlet to any building;
- (d) above a meter/regulator assembly within 3 ft. (900mm) horizontally of the vertical centerline of the regulator;
- (e) within 6 ft. (1.8m) of any gas service regulator vent outlet;
- (f) less than 1 ft. (300mm) above grade level;
- (g) within the following distances of a window or door which can be opened in any building, any non-mechanical air supply inlet to any building or the combustion air inlet of any other appliance:
 - (i) 1 ft (300mm) for inputs up to and including 100,000 Btu/h (30kW),
 - (ii) 3 ft (900mm) for inputs exceeding 100,000 Btu/h (30kW); and
- (h) underneath a veranda, porch or deck, unless
 - (i) the veranda, porch or deck is fully open on a minimum of two sides beneath the floor, and
 - (ii) the distance between the top of the vent termination and the underside of the veranda, porch or deck is greater than 1 ft. (300mm).

FOR COMPLIANCE TO NFPA 54 OR Z223.1 U.S.A.

Vent terminal must be located at least 3 feet above any forced air Inlet location within 10 feet away.

Vent terminal must not be located over public walk ways or be detrimental to regulators and equipment where condensate could be a problem.

Vent terminal must be kept clear of snow at all times.

The bottom of the vent terminal and the air intake must be located at least 12 inches above grade.

The vent terminal of a direct vent appliance with an input of 50,000 Btu per hour or less shall be located at least 9 inches from any opening through which flue gases could enter a building, and such an appliance with an input over 50,000 Btu per hour shall require a 12 inches vent termination clearance. The bottom of the vent terminal and the air intake shall be located at least 12 inches above grade.

LOCATION / CLEARANCES

When positioning the heater the main points governing the location are:

1. Flueing
2. Warm air distribution

This heater is not designed to be built in.

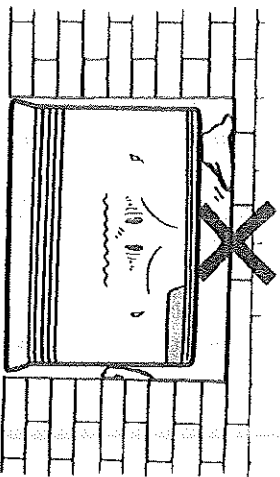

The flue terminal should be positioned away from flammable materials.

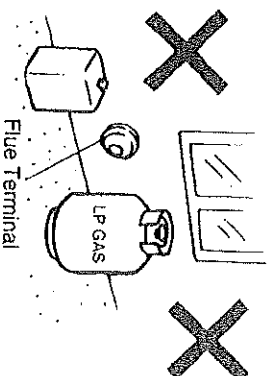

Do not flue into natural draught flues or fireplaces, this unit can only be used with one of the five types of Rinnai flue kits. Do not flue unit into other rooms. Flue terminal must be outside.

The flue is not designed to be positioned under floors, or below the level of the heater.

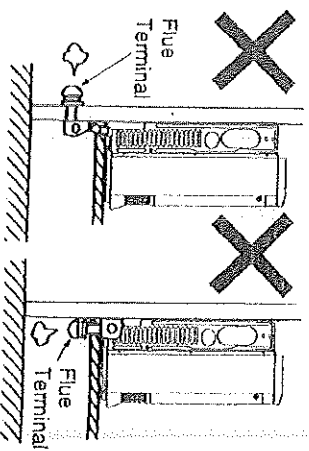

Flue may be positioned directly under opening windows, with a minimum clearance of 9" (230mm).

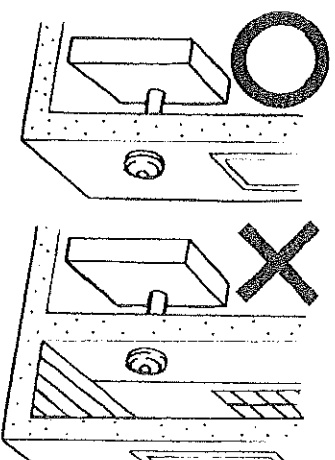

FLUE SIZES:

5 Flue lengths are available.

- S flue walls 3"~4 1/2" (75~115mm)
- A flue walls 4 1/2"~9 1/2" (115~240mm)
- B flue walls 9 1/2"~15 3/4" (240~400mm)
- C flue walls 15 3/4"~23 5/8" (400~600mm)
- D flue walls 23 5/8"~31 1/2" (600~800mm)

SNOW AREAS

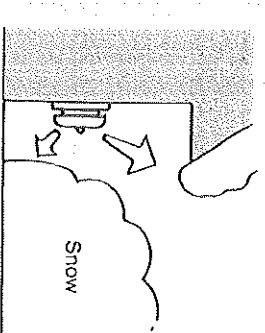

In areas subject to heavy snowfall, keep snow clear of flue terminal at all times.

STANDARD INSTALLATION OF FLUE MANIFOLD.

Diagram below shows minimum clearances and distances from obstructions.
Also check local regulations.

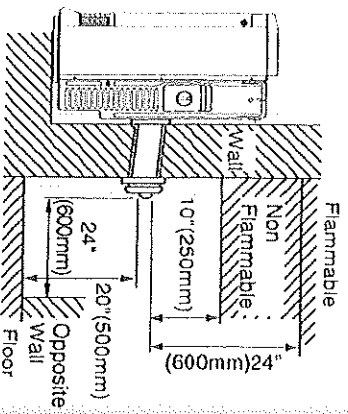

Side Clearances

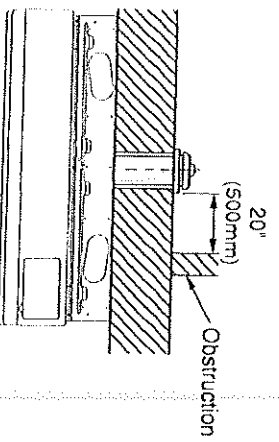

SLEEVE AND MANIFOLD INSTALLATION

METHOD FOR STANDARD WALLS

1. Disassemble Manifold from Sleeve.

The flue consists of 3 parts, sleeve, inside connectors and tube, outside terminal. (dis-assembly by pulling hard on outside terminal and inner connections, then pull sleeve off outer terminal.)

Note: Clearance to permit staples for terminal assembly is 0. Clearance for combustible for terminal assembly sleeve and flanges is 0.

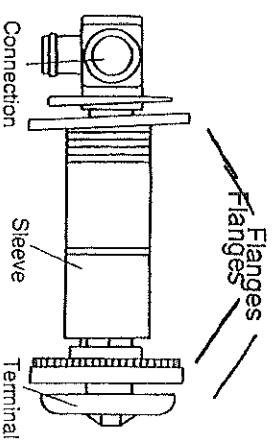

2. Adjustment of Sleeve Length.

Measure wall thickness through previously drilled 3 1/8" (80mm) hole.

End of sleeve should protrude 3/16"~3/8" (5~10mm) from outside wall. Adjust sleeve length to wall thickness plus 3/16"~3/8" (5~10mm). (Sleeve is threaded for adjustment.) Do not extend beyond red line.

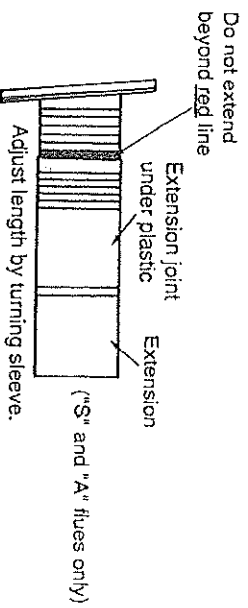

3. For S and A flue only.

Depending on flue set and wall thickness extension piece "C" may need to be removed.

Cut plastic, remove extension, then follow instruction 2. This applies to "S" and "A" flues only.

There is no extension on other flues, they can be fully adjusted by turning the threaded section.

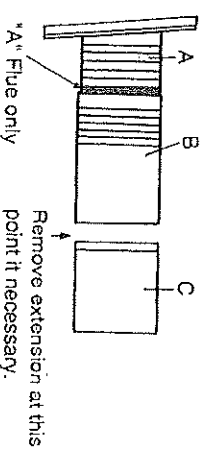

4. Fixing Sleeve.

Fix to the wall, using the 3 screws provided.

NOTE: The flange is marked "TOP", sleeve must be fitted with this mark **Up**. Check sleeve protrudes 3/16"~3/8" (5~10mm) on the outside.

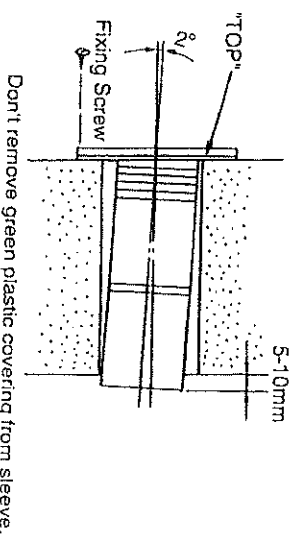

Don't remove green plastic covering from sleeve.

5. Check rubber seal is in place on terminal.

*For weather board walls, add spare rubber seal provided to compensate for weather board angle.

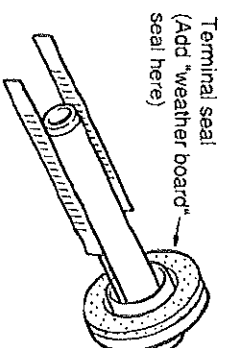

6. Installation of Terminal

From outside, insert terminal into sleeve with the "A" mark at the top. Left hand side fixing tie is marked "LEFT" (from inside).

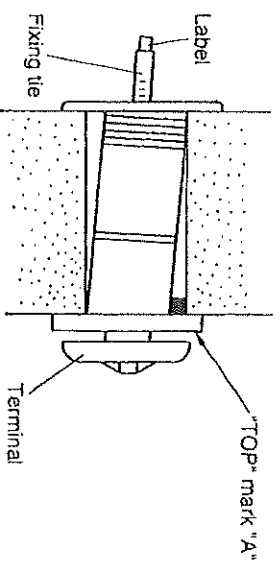

7. Attached Ties

Pull hard on left and right hand side ties, clip ties over lugs inside sleeve. You should be able to pull ties 2 or 3 slots past the starting point. Cut the ties, leaving about 3/4" (20mm) past the lugs. Bend ties so they are parallel with the wall.

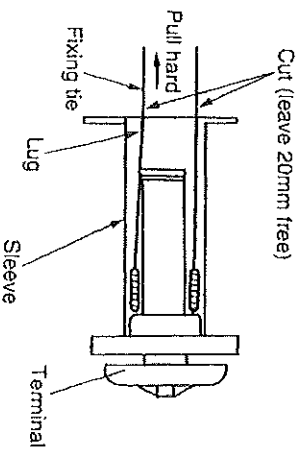

8. Insert Inner Connection Assembly.

Push assembly into the terminal tube, make sure "TOP" mark is uppermost. Fix with 3 screws provided.

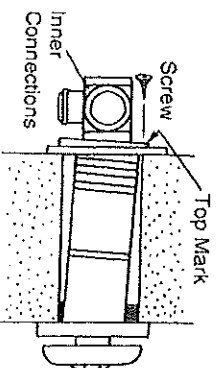

9. Manifold can still be turned after attaching.

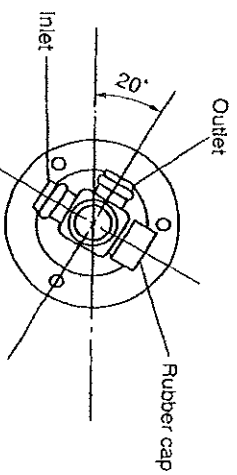

FITTING UNIT

1. Fix Flue Adapter to Flue Manifold with PIPE STOPPER S as shown below.

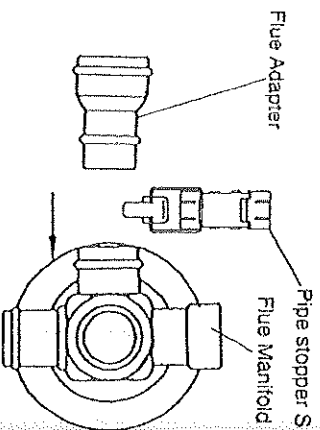

2. Fit Wall bracket as shown below.

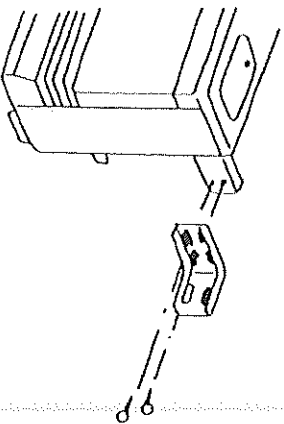

3. Fit Air Inlet Hose to heater. Fix Side Back Spacers with screws.

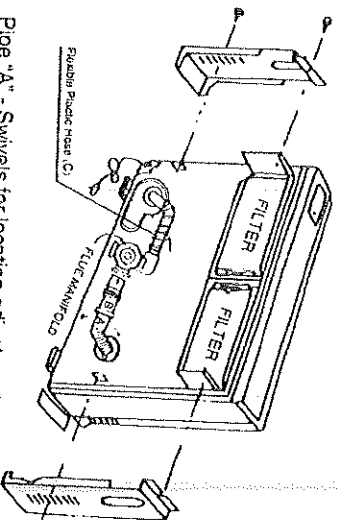

Pipe "A" - Swivels for location adjustment
 Pipe "B" - Telescopic-telescopes into pipe A and flue manifold
 Pipe "C" - Fits on manifold "Air Intake" pipe

Air Inlet Hose
 Connect Air Inlet Hose to Manifold Inlet.
 Do not kink the hose.

4. Secure with plastic tie as shown below.

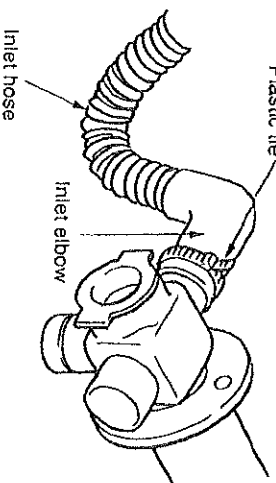

When servicing unit replace plastic tie with new one.
 (Available at local hardware store or contact local distributor.)

5. Connect Vent Sliding Tube with PIPE STOPPER S and E as shown below.

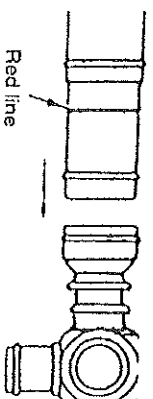
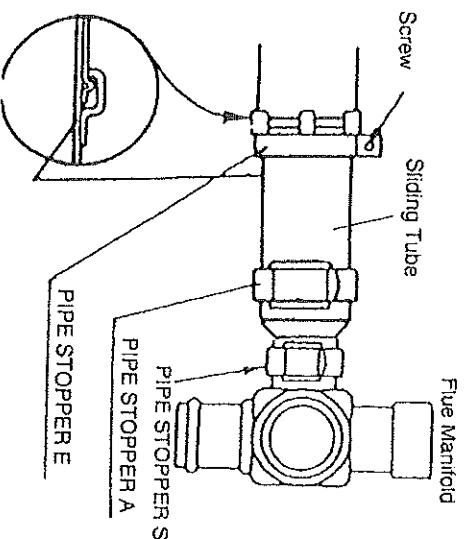

Sliding Tube should not be extended beyond the RED LINE.
 Red line should not be visible after sliding the tube back into the vent outlet.

6. Slide the insulation sleeve up to the flue manifold, slip the securing clip over the sleeve as shown.

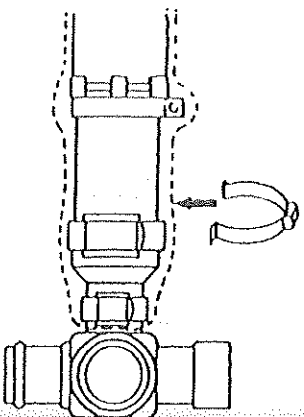

7. Fix Back Spacer, Top to heater. (3 screws in top back cover).

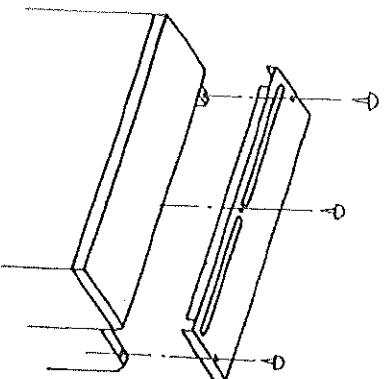

8. If necessary, the unit can be levelled using the adjustable legs under the front right and left hand side legs.

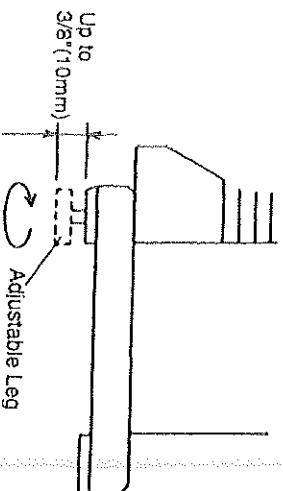

■ INSTRUCT CUSTOMER ON USE OF HEATER

When you are satisfied that the appliance is operating correctly, explain operation of heater to the customer.

Fault-Failure Procedure

If unable to get the heater to operate correctly, contact Flinnal directly or your Agent or Gas Utility.

Do not use electrical extension cords to connect unit to power supply. Keep the power cord away from the flue.

Some items are not covered under the unit's warranty. Example: annual maintenance, carbon on flame rods/igniter, dust, spider webs, improper conversions, etc.