

PERMIT ISSUED

City of Portland, Maine - Building or Use Permit Application
 389 Congress Street, 04101 Tel: (207) 874-8703, Fax: (207) 874-8716

Permit No:	03-0530	Issue Date:	MAY 28 2003	CBL:	403 C012001
------------	---------	-------------	-------------	------	-------------

Location of Construction:	31 Nevada Ave	Owner Name:	Huntley Elizabeth A &	Owner Address:	31 Nevada Ave	Phone:	797-2798
Business Name:		Contractor Name:	Risbara Bros Construction	Contractor Address:	197 US Route 1 Scarborough	Phone:	2078835528
Lessee/Buyer's Name:		Phone:		Permit Type:	Alterations - Dwellings	Zone:	R3

Past Use:	Single Family	Proposed Use:	Single Family: Replace two windows with a sliding door, build an 8' x 22' deck	Permit Fee:	\$44.00	Cost of Work:	\$0.00	CEO District:	2
Proposed Project Description:	Replace two windows with a sliding door, build an 8' x 22' deck			FIRE DEPT:	<input type="checkbox"/> Approved <input type="checkbox"/> Denied	INSPECTION:	Use Group: R3 Type: SB	Signature:	Risbara Bros 5/28/03

Permit Taken By:	Date Applied For:	Special Zone or Reviews	Zoning Appeal	Historic Preservation
kw/d	05/16/2003	<input type="checkbox"/> Shoreland <input type="checkbox"/> Wetland <input type="checkbox"/> Flood Zone <input type="checkbox"/> Subdivision <input type="checkbox"/> Site Plan Maj <input type="checkbox"/> Minor <input type="checkbox"/> MM <input type="checkbox"/> Date: 5/28/03	<input type="checkbox"/> Variance <input type="checkbox"/> Miscellaneous <input type="checkbox"/> Conditional Use <input type="checkbox"/> Interpretation <input type="checkbox"/> Approved <input type="checkbox"/> Denied Date:	<input checked="" type="checkbox"/> Not in District or Landmark <input type="checkbox"/> Does Not Require Review <input type="checkbox"/> Requires Review <input type="checkbox"/> Approved <input type="checkbox"/> Approved w/Conditions <input type="checkbox"/> Denied Date:

Zoning Approval

- This permit application does not preclude the Applicant(s) from meeting applicable State and Federal Rules.
- Building permits do not include plumbing, septic or electrical work.
- Building permits are void if work is not started within six (6) months of the date of issuance. False information may invalidate a building permit and stop all work..

CERTIFICATION

I hereby certify that I am the owner of record of the named property, or that the proposed work is authorized by the owner of record and that I have been authorized by the owner to make this application as his authorized agent and I agree to conform to all applicable laws of this jurisdiction. In addition, if a permit for work described in the application is issued, I certify that the code official's authorized representative shall have the authority to enter all areas covered by such permit at any reasonable hour to enforce the provision of the code(s) applicable to such permit.

SIGNATURE OF APPLICANT

ADDRESS

DATE

PHONE

RESPONSIBLE PERSON IN CHARGE OF WORK, TITLE

DATE

PHONE

City of Portland, Maine - Building or Use Permit

389 Congress Street, 04101 Tel: (207) 874-8703, Fax: (207) 874-8716

Permit No:	03-0530	Date Applied For:	05/16/2003	CBL:	403 C012001
------------	---------	-------------------	------------	------	-------------

Location of Construction:	31 Nevada Ave	Owner Name:	Hunley Elizabeth A &	Owner Address:	31 Nevada Ave	Phone:	() 797-2798
Business Name:		Contractor Name:	Risbara Bros Construction	Contractor Address:	197 US Route 1 Scarborough	Phone:	(207) 883-5528
Lessee/Buyer's Name		Phone:		Permit Type:	Alterations - Dwellings		

Proposed Use:	Single Family: Replace two windows with a sliding door, build an 8' x 22' deck	Proposed Project Description:	Replace two windows with a sliding door, build an 8' x 22' deck
---------------	--	-------------------------------	---

Dept: Zoning Status: Approved Reviewer: Jeanine Bourke Approval Date: 05/28/2003
 Note: Ok to Issue:

1) This property shall remain a single family dwelling. Any change of use shall require a separate permit application for review and approval.

Dept: Building Status: Approved with Conditions Reviewer: Jeanine Bourke Approval Date: 05/28/2003
 Note: Ok to Issue:

1) There are no stairs shown on the plans from the new deck, if installed, will need to submit details

2) Application approval based upon information provided by applicant. Any deviation from approved plans requires separate review and approval prior to work.

03-0530

All Purpose Building Permit Application

If you or the property owner owes real estate or personal property taxes or user charges on any property within the City, payment arrangements must be made before permits of any kind are accepted.

Location/Address of Construction: 31 NWINDA ST.	
Total Square Footage of Proposed Structure 176 sq'	Square Footage of Lot UNKNOWN
Tax Assessor's Chart, Block & Lot Chart# 403 Block# C Lot# 012	Owner: Ken & Elizabeth Huntley
Lessee/Buyer's Name (if Applicable) N/A	Applicant name, address & telephone: RISHA BROS. CONST CO P.O. Box 485 Seabrook, ME 603-5518
Current use: Single Family Dwelling.	Cost Of Work: \$ 3,000.00 Fee: \$ 440.00
If the location is currently vacant, what was prior use: _____	
Approximately how long has it been vacant: _____	
Proposed use: _____	
Project description: THE OUT 2 WINDOWS INSTAL A SLIDER, BULD A 8'x22' P.T. DEK.	
Contractor's name, address & telephone: P.O. Box 485 Seabrook, ME. 603-5528	
Who should we contact when the permit is ready: _____	
Mailing address: P.O. Box 485	

We will contact you by phone when the permit is ready. You must come in and pick up the permit and review the requirements before starting any work with a Plan Reviewer. A stop work order will be issued and a \$100.00 fee if any work starts before the permit is picked up. PHONE: **603-5528**

IF THE REQUIRED INFORMATION IS NOT INCLUDED IN THE SUBMISSIONS THE PERMIT WILL BE AUTOMATICALLY DENIED AT THE DISCRETION OF THE BUILDING/PLANNING DEPARTMENT, WE MAY REQUIRE ADDITIONAL INFORMATION IN ORDER TO APPROVE THIS PERMIT.

I hereby certify that I am the Owner of record of the named property, or that the owner of record authorizes the proposed work and that I have been authorized by the owner to make this application as his/her authorized agent. I agree to conform to all applicable laws of this jurisdiction. In addition, if a permit for work described in this application is issued, I certify that the Code Official's original signature is a true and correct copy of the original signature. I agree to accept the provisions of the codes applicable to this permit.

Signature of applicant: *Ken & Elizabeth Huntley* Date: 5-16-05

**DEPT. OF BUILDING INSPECTION
CITY OF PORTLAND, ME**

This is NOT a permit, you may not commence ANY work until the permit is issued. If you are in a Historic District you may be subject to additional permitting and fees with the Planning Department on the 4th floor of City Hall

100' PROPERTY LINE

Key: Lindem Hunter
31 NAVADA ST.
DORLAND, MARIJE

R3 Zone
Side 8' Req 15' Shown

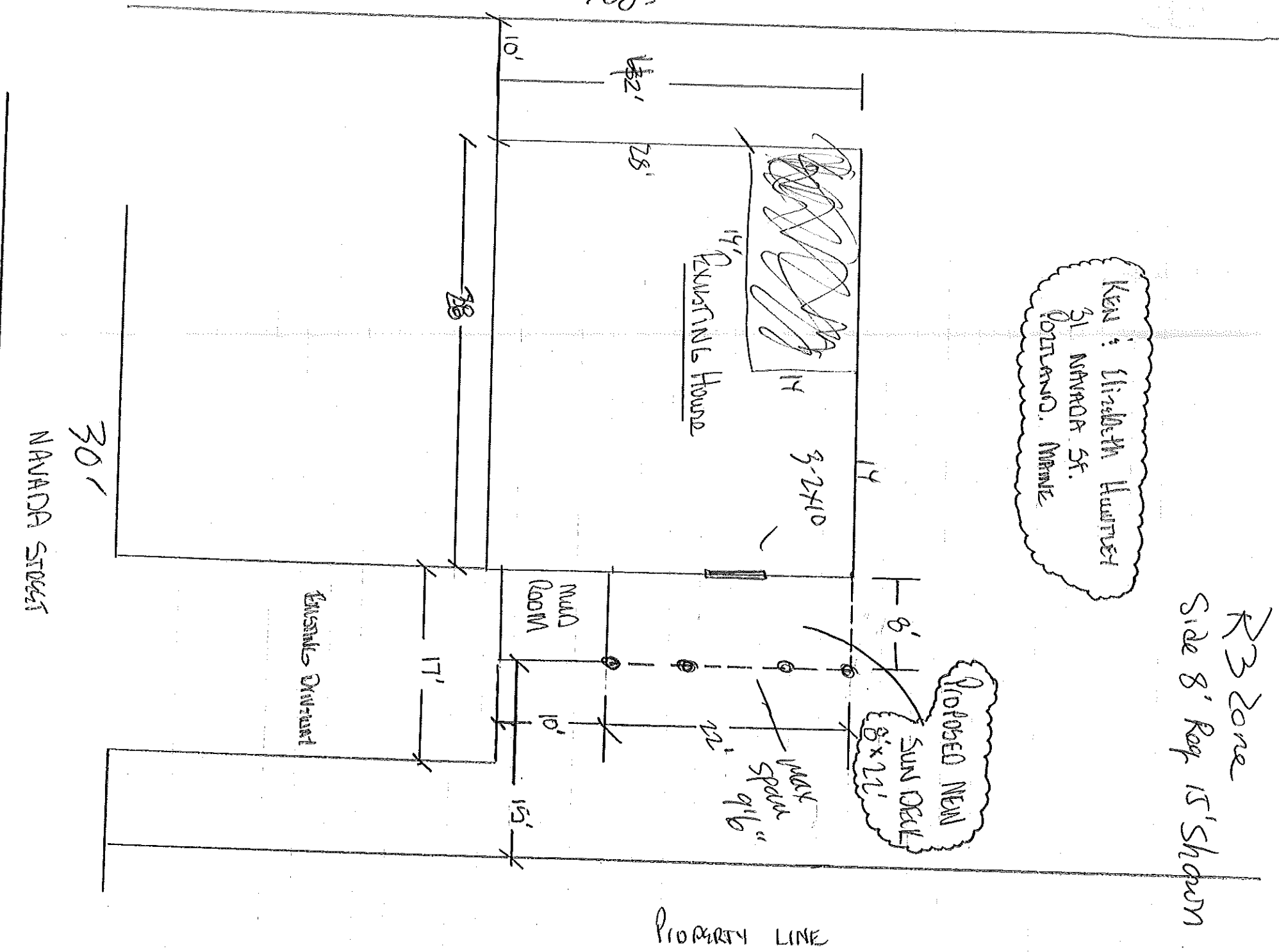

PROPERTY LINE

Sun Deck Design

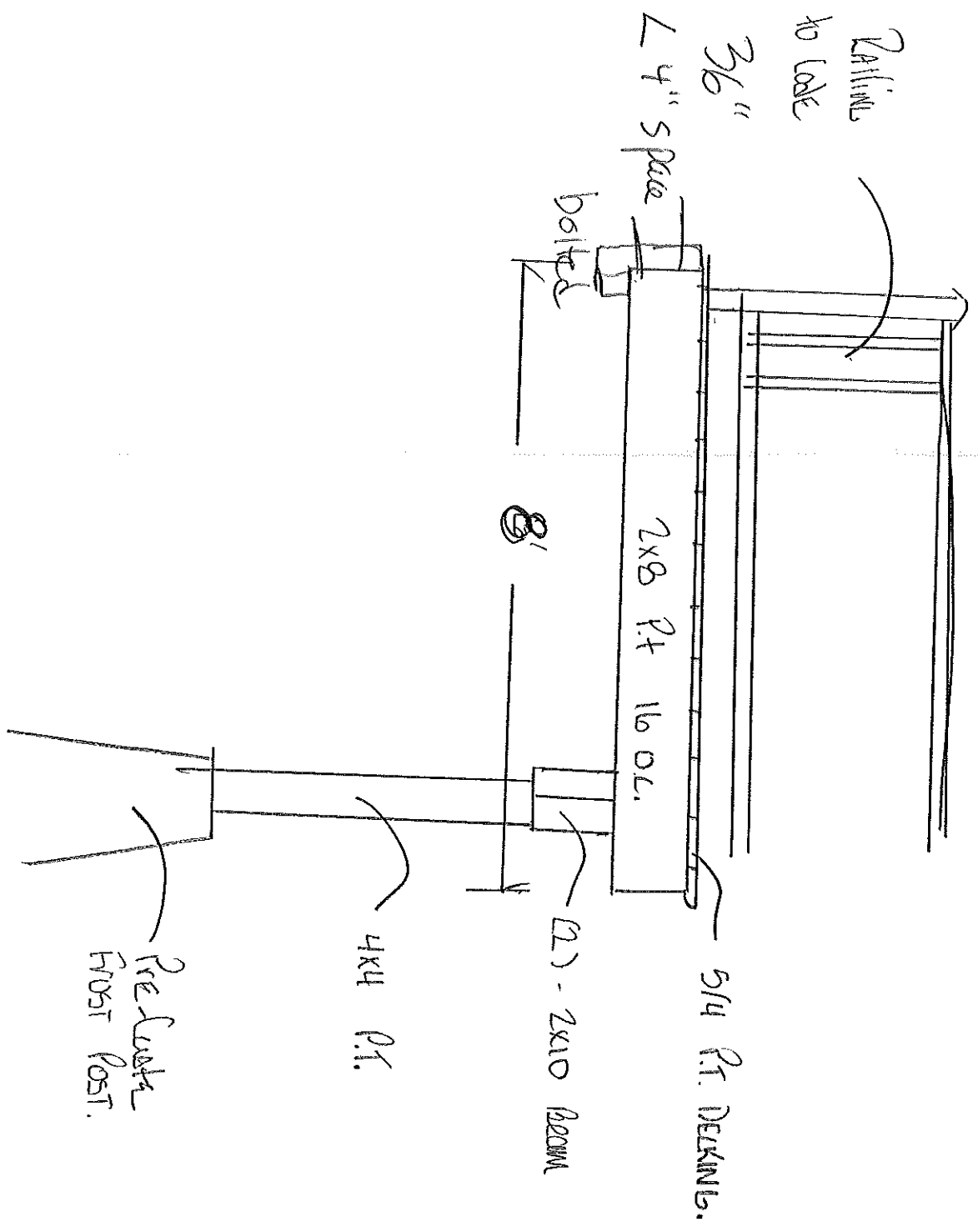

60x100

R3 zone

Descriptor/Area

A: FA/TF/B
980 sqft

B: EP
80 sqft

> 1060

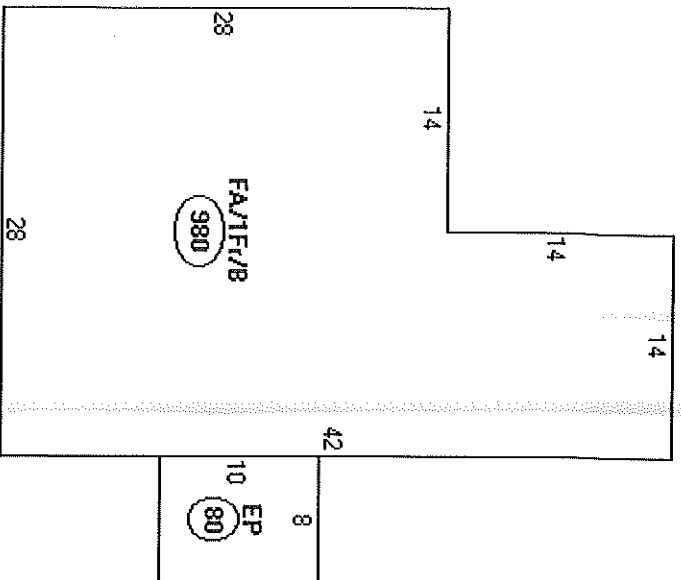

6000 ft x 25%

1500

New 76

OK

1060

~~1236~~

This page contains a detailed description of the Parcel ID you selected. Press the **New Search** button at the bottom of the screen to submit a new query.

Current Owner Information

R-3

Card Number 1 of 1
 Parcel ID 403 C012001
 Location 31 NEVADA AVE
 Land Use ~~TWO FAMILY~~ *one Family*
 Owner Address HUNTLEY ELIZABETH A & KENNETH HUNTLEY JTS
 31 NEVADA AVE
 PORTLAND ME 04103

Book/Page 15518/078
 Legal 403-C-12-13
 NEVADA AVE 29-31
 6000 SF

Valuation Information

Land \$31,400 Building \$54,600 Total \$86,000

Property Information

Year Built 1942	Style Ranch	Story Height 1	Sq. Ft. 1225	Total Acres 0.138
Bedrooms 2	Full Baths 1	Half Baths	Total Rooms 5	Attic Part Finsh
				Basement Full

Outbuildings

Type	Quantity	Year Built	Size	Grade	Condition
------	----------	------------	------	-------	-----------

Sales Information

Date	Type	Price	Book/Page
12/01/2002	LAND + BLDING		15518-78
07/31/2001	LAND + BLDING		15578-238
05/16/1994	LAND + BLDING	\$84,000	11489-032

Picture and Sketch

[Picture](#)

[Sketch](#)

[Click here to view Tax Roll Information.](#)

Any information concerning tax payments should be directed to the Treasury office at 874-8490 or e-mailed.

New Search!

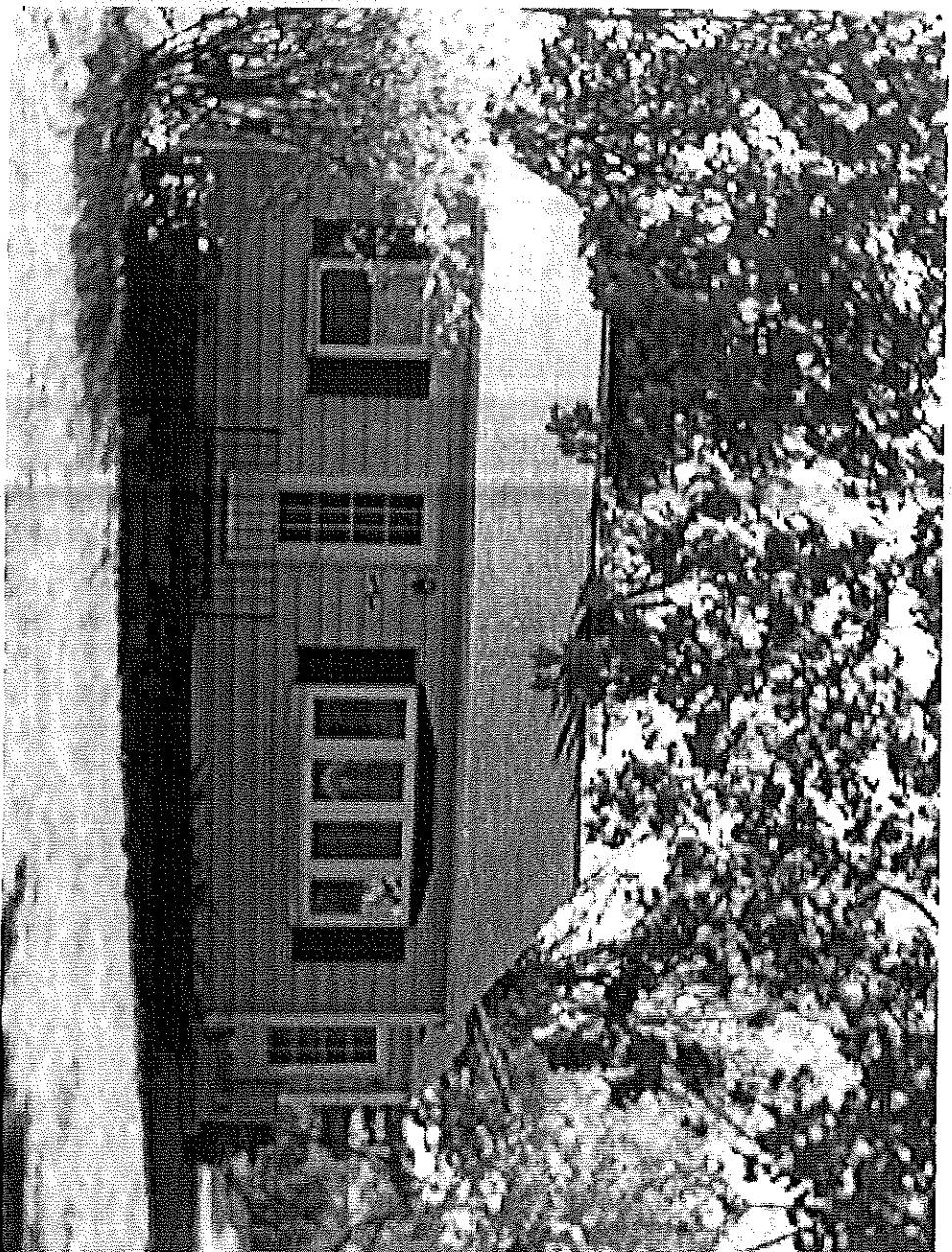

DISPLAY THIS CARD ON PRINCIPAL FRONTAGE OF WORK CITY OF PORTLAND

Please Read Application And Notes, If Any, Attached

BUILDING INSPECTION PERMIT

PERMIT ISSUED

Permit Number: 030530

MAY 28 2003

This is to certify that Hunley Elizabeth A & Risha

Bro Co

has permission to Replace two windows with a

ing door

uild an

22' de

At 31 Nevada Ave

403 C012001

CITY OF PORTLAND

provided that the person or persons, firm or corporation accepting this permit shall comply with all of the provisions of the Statutes of Maine and of the ordinances of the City of Portland regulating the construction, maintenance and use of buildings and structures, and of the application on file in this department.

Apply to Public Works for street line and grade if nature of work requires such information.

Notification inspection must be made and written permit procured before this building or structure is occupied or closed-in. A NOTICE IS REQUIRED.

A certificate of occupancy must be procured by owner before this building or part thereof is occupied.

OTHER REQUIRED APPROVALS

Fire Dept. _____

Health Dept. _____

Appeal Board _____

Other _____

Department Name

PENALTY FOR REMOVING THIS CARD

Samuel P. Strubbe
Director of Building & Inspection Services

BUILDING PERMIT INSPECTION PROCEDURES

Please call 874-8703 or ~~874-8693~~ to schedule your inspections as agreed upon

Permits expire in 6 months, if the project is not started or ceases for 6 months.

The Owner or their designee is required to notify the inspections office for the following inspections and provide adequate notice. Notice must be called in 48-72 hours in advance in order to schedule an inspection:

By initializing at each inspection time, you are agreeing that you understand the inspection/procedure and additional fees from a "Stop Work Order" and "Stop Work Order Release" will be incurred if the procedure is not followed as stated below.

Pre-construction Meeting: Must be scheduled with your inspection team upon receipt of this permit. Jay Reynolds, Development Review Coordinator at 874-8632 must also be contacted at this time, before any site work begins on any project other than single family additions or alterations.

Footing/Building Location Inspection: Prior to pouring concrete

Re-Bar Schedule Inspection: Prior to pouring concrete

Foundation Inspection: Prior to placing ANY backfill

Framing/Rough Plumbing/Electrical: Prior to any insulating or drywalling

Final/Certificate of Occupancy: Prior to any occupancy of the structure or use. ~~NOTE: There is a \$75.00 fee per inspection at this point.~~

Certificate of Occupancy is not required for certain projects. Your inspector can advise you if your project requires a Certificate of Occupancy. All projects DO require a final inspection

If any of the inspections do not occur, the project cannot go on to the next phase, REGARDLESS OF THE NOTICE OR CIRCUMSTANCES.

CERTIFICATE OF OCCUPANCIES MUST BE ISSUED AND PAID FOR, BEFORE THE SPACE MAY BE OCCUPIED

[Signature]
Signature of applicant/designee
Date 5/29/03
[Signature]
Signature of Inspections Official
Date 5/29/03

CBL: 403-0-12 Building Permit #: 03-0530

PLEASE CALL 874-8703 OR 874-8693 TO SCHEDULE YOUR
INSPECTIONS AS AGREED UPON

Permits expire in 6 months, if the project is not started or ceases for 6 months.

The Owner or their designee is required to notify the inspections office for the following inspections and provide adequate notice. Notice must be called in 48-72 hours in advance in order to schedule an inspection.

By initializing at each inspection time, you are agreeing that you understand the inspection procedure and additional fees from a "Stop Work Order" and "Stop Work Order Release" will be incurred if the procedure is not followed as stated below.

A Pre-construction Meeting will take place upon receipt of your building permit.

Footing/Building Location Inspection: Prior to pouring concrete

Re-Bar Schedule Inspection: Prior to pouring concrete

Foundation Inspection: Prior to placing ANY backfill

Framing/Rough Plumbing/Electrical: Prior to any insulating or drywalling

Final/Certificate of Occupancy: Prior to any occupancy of the structure or use. NOTE: There is a \$75.00 fee per inspection at this point.

Certificate of Occupancy is not required for certain projects. Your inspector can advise you if your project requires a Certificate of Occupancy. All projects DO require a final inspection.
 If any of the inspections do not occur, the project cannot go on to the next phase, REGARDLESS OF THE NOTICE OR CIRCUMSTANCES.

CERTIFICATE OF OCCUPANCIES MUST BE ISSUED AND PAID FOR BEFORE THE SPACE MAY BE OCCUPIED

Richard Barrios 9-25-06
Signature of Applicant/Designee Date

Paul G. [Signature] 9-25-06
Signature of Inspections Official Date

CBL NO3 E012 Building Permit #: 061037