

BUILDING PERMIT INSPECTION PROCEDURES

Please call 874-8703 or 874-8693 to schedule your inspections as agreed upon

Permits expire in 6 months, if the project is not started or ceases for 6 months.

The Owner or their designee is required to notify the inspections office for the following inspections and provide adequate notice. Notice must be called in 48-72 hours in advance in order to schedule an inspection:

By initializing at each inspection time, you are agreeing that you understand the inspection procedure and additional fees from a "Stop Work Order" and "Stop Work Order Release" will be incurred if the procedure is not followed as stated below.

Pre-construction Meeting: Must be scheduled with your inspection team upon receipt of this permit. Jay Reynolds, Development Review Coordinator at 874-8632 must also be contacted at this time, before any site work begins on any project other than single family additions or alterations.

JR Footing/Building Location Inspection: Prior to pouring concrete

LA Re-Bar Schedule Inspection: Prior to pouring concrete

UA Foundation Inspection: Prior to placing ANY backfill

OA Framing/Rough Plumbing/Electrical: Prior to any insulating or drywalling

JR Final/Certificate of Occupancy: Prior to any occupancy of the structure or use. NOTE: There is a \$75.00 fee per inspection at this point.

Certificate of Occupancy is not required for certain projects. Your inspector can advise you if your project requires a Certificate of Occupancy. All projects DO require a final inspection

 If any of the inspections do not occur, the project cannot go on to the next phase, REGARDLESS OF THE NOTICE OR CIRCUMSTANCES.

 CERTIFICATE OF OCCUPANCIES MUST BE ISSUED AN PAID FOR, BEFORE THE SPACE MAY BE OCCUPIED

[Signature] 1/30/02
Signature of applicant/designee Date

[Signature] 1/30/02
Signature of Inspections Official Date

CBL: 321-A-2 Building Permit #: 02-0025



CITY OF PORTLAND

January 31, 2002

Mr. Bernie Clark
Bernie's Auto Repair
522 Riverside Street
Portland, ME 04103

RE: Bernie's Auto Repair, 522 Riverside Street
ID# 1999-0167, CBL #321-A-002

Dear Mr. Clark:

We are in receipt of your amended site plan, which was submitted to address overflow parking for your project located at 522 Riverside Street. The amended plan includes the pavement of a curbed parking area in the rear of the building, the relocation of the dumpster pad and additional fencing. The following will have to be addressed prior to approval of the amended site plan.

- (a) Submit in writing the use of the entire site. Why is there such always a large amount of vehicles on-site? It appears that there are currently more than seventeen (17) vehicles parked on your site. Are seventeen (17) overflow parking spaces going to be adequate for storage? A condition will be placed on the amended site plan that the storage of vehicles will be limited to the number of parking spaces shown at the rear of the site. If seventeen (17) spaces are not adequate, then let's address this now instead of going through this exercise again.

For approval of the amended site plan, the City will require the following items. A plan is enclosed for your reference.

- (b) Curb will be required around the islands along Riverside Street, as shown on the enclosed plan.
- (c) Guardrails will be required along the edge of all parking areas, as shown on the enclosed plan.
- (d) As mentioned above, the storage of vehicles at the rear of the site will be limited to the number of parking spaces shown on the amended plan. A note shall be added to the plan stating this.
- (e) A plan shall be revised and submitted with (b), (c), and (d) shown on the plan.
- (f) A performance guarantee in the amount of pavement, curbing, fencing and guardrails shall be submitted to the City, which will be held until all work required for the amended site plan is completed.

1/9/02
I Roy Clark do hereby give
permission to Custom Fabrication
to install a Sign of his design at
my location, 522 Riverside St.
Portland, Me.

A handwritten signature in cursive script, appearing to read "Roy Clark". The signature is written in dark ink and is positioned below the main text of the document.

Application ID Number: 2-0025

Department: [Redacted] Zoning: [Redacted] Status: Approved with Conditions Reviewer: Marge Schmuckal

Comments: 522 Riverside St. Approval Date: 01/14/2002

Given On Date: 01/11/2002

OK to Issue Permit Name: Marge Schmuckal Date: 01/14/2002 Date 2: [Redacted]

Conditions Section

It is understood from our phone conversation that the sign to the highest part of the arch is 5 feet and that the entire sign will not be higher than 10 feet at the highest point.

Create Date: 01/10/2002 By: [Redacted] Update Date: 01/14/2002 By: mes

THIS IS NOT A PERMIT/CONSTRUCTION MAY NOT COMMENCE UNTIL THE PERMIT IS ISSUED

SIGNAGE APPLICATION

THIS IS NOT A PERMIT
CONSTRUCTION CANNOT NOT COMMENCE UNTIL THE PERMIT IS ISSUED

In the interest of processing your application in the quickest possible manner, please complete the information below for a Building or Use Permit.

If you or the property owner owes real estate or personal property taxes or user charges on any property within the City, payment arrangements must be made before permits of any kind are accepted.

Location/Address of Construction: <u>522 Riverside ST</u>		
Total Square Footage of Proposed Structure <u>35 sq ft</u>	Square Footage of Lot	
Tax Assessor's Chart, Block & Lot Number	Owner: <u>Bernie's Auto</u>	Telephone #: <u>878-0181</u>
Chart# <u>321</u> Block# <u>A</u> Lot# <u>002</u>		
Lessee/Buyer's Name (If Applicable)	Owner's/Purchaser/Lessee Address:	Total s.f. of signs <u>35 sq ft</u> 20 \$ <u>7</u> , plus \$30.00 TOTAL \$ <u>37.00</u>
Current use: <u>Commercial / Auto Repair</u>	Proposed use: <u>Same</u>	
Project description: <u>5'x7' Internally illuminated sign with pole cover</u>		
Applicants Name, Address & Telephone: <u>Bernie's Auto Repair</u> <u>522 Riverside ST</u> <u>878-0181</u>		
Contractor's Name, Address & Telephone: <u>Custom Fabrication</u> <u>34 Spear Rd Standish me 04084</u>		
Who shall we contact when the permit is ready: <u>John Langier</u>		
Telephone: <u>642-8998</u>		
If you would like it mailed, what mailing address should we use:		

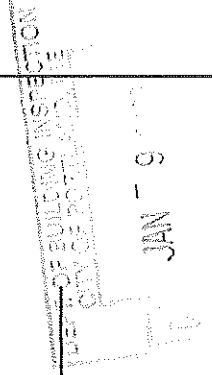

Rec'd By:

John
642-8998

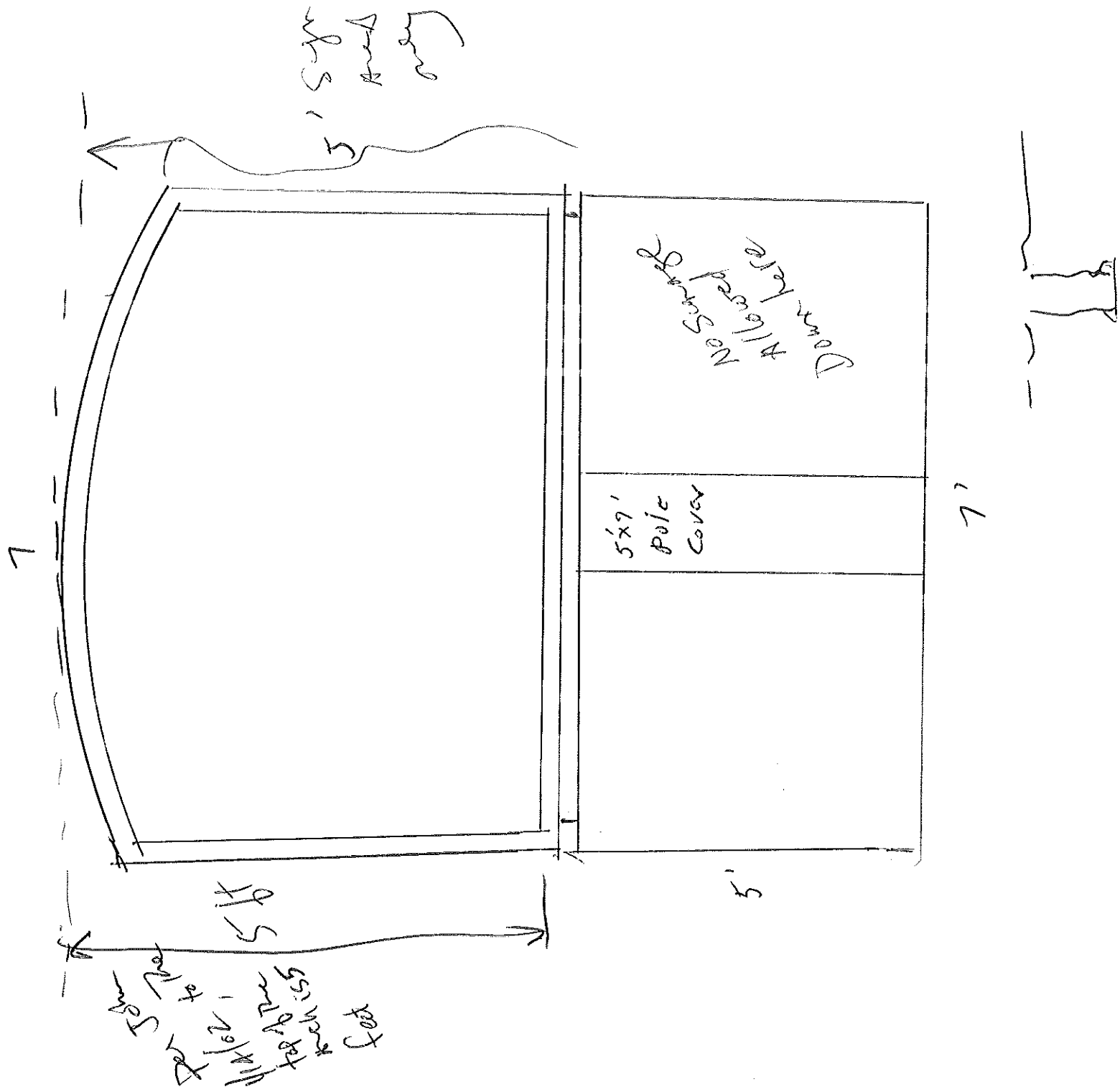

SIGNAGE PRE-APPLICATION

PLEASE ANSWER ALL QUESTIONS

ADDRESS: 522 Riverside St Portland, wa ZONE: I-M

OWNER: Bernie's Auto Repair

APPLICANT: Custom Fabrication John Langis

ASSESSOR NO. _____

PLEASE CIRCLE APPROPRIATE ANSWER

SINGLE TENANT LOT? YES NO MULTI-TENANT LOT? YES NO

FREESTANDING SIGN? (ex. Pole Sign) YES NO DIMENSIONS 5' x 7' HEIGHT 10'

MORE THAN ONE SIGN? YES NO DIMENSIONS _____ HEIGHT _____

SIGN ATTACHED TO BLDG.?: YES NO DIMENSIONS _____

MORE THAN ONE SIGN? YES NO DIMENSIONS _____

AWNING: YES NO IS AWNING BACKLIT? YES NO HEIGHT OFF SIDEWALK

IS THERE ANY MESSAGE, TRADEMARK OR SYMBOL ON IT?

LIST ALL EXISTING SIGNAGE AND THEIR DIMENSIONS:
None

*** TENANT BLDG. FRONTAGE (IN FEET): _____
*** REQUIRED INFORMATION

AREA FOR COMPUTATION

I-M

max size = 35' - 35' to sign

max height = 10' - 10' shown

min setback = 5' 5' set back per drawing

YOU SHALL PROVIDE:

A SITE SKETCH AND BUILDING SKETCH SHOWING EXACTLY WHERE EXISTING AND NEW SIGNAGE IS LOCATED MUST BE PROVIDED. SKETCHES AND/OR PICTURES OF PROPOSED ARE ALSO REQUIRED.

SIGNATURE OF APPLICANT: John Langis DATE: 1/9/02

The Law Office of Gary M. Proffman

482 Congress Street, Suite 300
Portland, ME 04101
(207) 773-3506
Fax (207) 773-3712

321-A-2

July 3, 2002

VIA FAX & U.S. MAILS

Alexander Jaegerman
Planning Division Director
City of Portland
389 Congress Street
Portland, Maine 04101

Re: **Bernie's Auto Repair**
522 Riverside Street
ID No. 1999-0167, CBL #321-A-002

Dear Alex:

I had the opportunity to speak with Bernie with regard to the above-entitled matter and it appears as though your committee has environmental problems with the "fill" that Bernie has suggested for the ravine that abuts the parking area. I am sure that your associates will tell you from their being out on the premises, Bernie has made significant strides on the property pursuant to all of your requests. In addition, we are in the process of getting a letter indicating that the fill that Bernie has proposed is actually good fill and should not present any environmental problem for the City. I would also like to note that there is a major amount of trash that is being dumped in that ravine by the business on the other side of the ravine. Bernie has told me that he does not want to get anyone in trouble, however, if you look at the garbage, you will see that it is not coming from Bernie's Auto Repair. I would suggest that your associates take another look at who is doing the "dumping" inappropriate garbage down that ravine.

In any event, it appears as though most everything is going in the right direction and that the remaining issue will be this above-mentioned "fill" dispute. I should have a letter from a representative of DEP and/or someone from the Environmental Protection Agency with regard to the adequacy of the "fill" in the immediate future. I believe that this will put your associates fears to rest. Perhaps, they could send me some type of documentation as to why granite is not good fill!



STATE OF MAINE
DEPARTMENT OF ENVIRONMENTAL PROTECTION

ANGUS S. KING, JR.
GOVERNOR

MARTHA KIRKPATRICK
COMMISSIONER

July 8, 2002

Roy B. Clark
Bernie's Auto Repair
522 Riverside Street
Portland, ME 04103

Dear Mr. Clark:

321-A-2

This letter is a follow up to my June 26th meeting with you at your auto repair facility at 522 Riverside Street in Portland. As you know, the purpose of my visit was to ensure that the fill material used in the project conforms to the Department's Solid Waste Regulations. It appears that a significant quantity of fill material has been placed on your property. Since I was only able to observe the exposed embankment, I cannot be certain that all of the fill is inert. Most of the fill material that I observed during my visit would, however, constitute inert fill as defined in CMR 06-096 Chapter 400 §1.RRR and would therefore be exempt from the Department's Solid Waste Regulations. I did see a few pieces of demolition wood, asphalt pavement, and other materials in the fill, but not of a type or quantity that would require removal.

You should also keep in mind that I am only able to comment on the fill material used and in the context of the Department's Solid Waste Regulations. I strongly recommend that you contact someone in the Department's Bureau of Land and Water Quality, and contact the City of Portland Code Enforcement Office to make sure that you are in compliance with other applicable regulations. Will Cook would be a good contact person in the Department's Bureau of Land and Water Quality. He can be reached at 822-6325. If you have any questions, please feel free to contact me at 822-6344.

Sincerely,

Eric P. Hamlin
Bureau of Remediation and Waste Management
Division of Solid Waste Management

AUGUSTA
15 STATE HOUSE STATION
AUGUSTA, MAINE 04333-0017
(207) 287-7688
RAY BLDG., HOSPITAL ST.

BANGOR
186 HOGAN ROAD
BANGOR, MAINE 04401
(207) 941-4576 FAX: (207) 941-4584

PORTLAND
312 CANCO ROAD
PORTLAND, MAINE 04103
(207) 822-6300 FAX: (207) 822-6303

PRESQUE ISLE
1235 CENTRAL DRIVE, SKYWAY PARK
PRESQUE ISLE, MAINE 04769-2004
(207) 764-0477 FAX: (207) 764-1507