



# PORTLAND MAINE

*Strengthening a Remarkable City, Building a Community for Life • [www.portlandmaine.gov](http://www.portlandmaine.gov)*

Jeff levine, AICP, Director  
Director of Planning and Urban Development

Tammy Munson  
Director, Inspections Division

## **Electronic Signature and Fee Payment Confirmation**

*Notice: Your electronic signature is considered a legal signature per state law.*

By digitally signing the attached document(s), you are signifying your understanding this is a legal document and your electronic signature is considered a **legal signature** per Maine state law. You are also signifying your intent on paying your fees by the opportunities below.

I, the undersigned, intend and acknowledge that no permit application can be reviewed until payment of appropriate permit fees are **paid in full** to the Inspections Office, City of Portland Maine by method noted below:



Within 24-48 hours, once my complete permit application and corresponding paperwork has been electronically delivered, I intend to **call the Inspections Office** at 207-874-8703 and speak to an administrative representative and provide a credit/debit card over the phone.



Within 24-48 hours, once my permit application and corresponding paperwork has been electronically delivered, I intend to **hand deliver** a payment method to the Inspections Office, Room 315, Portland City Hall.



I intend to deliver a payment method through the U.S. Postal Service mail once my permit paperwork has been electronically delivered.

Applicant Signature:

Date: 5/13/14

I have provided digital copies and sent them on:

Date: 5/13/14

NOTE: All electronic paperwork must be delivered to [buildinginspections@portlandmaine.gov](mailto:buildinginspections@portlandmaine.gov) or by physical means ie; a thumb drive or CD to the office.

Room 315 - 389 Congress Street- Portland, Maine 04101 (207) 874-8703 - Fax: 874-8716 - TTY: 874-8936

# SUBSURFACE WASTEWATER DISPOSAL SYSTEM APPLICATION

Maine Department of Human Services  
Division of Health Engineering, 10 SHS  
(207) 287-5672 Fax: (207) 287-3165

<b>PROPERTY LOCATION</b>		<b>CAUTION: PERMIT REQUIRED - ATTACH IN SPACE BELOW</b>	
City, Town, or Plantation	Portland (Cliff Island)	The Subsurface Wastewater Disposal System shall not be installed until a Permit is attached HERE by the Local Plumbing Inspector. The Permit shall authorize the owner or installer to install the disposal system in accordance with this application and the Maine Subsurface Wastewater Disposal Rules.	
Street or Road	62, 68, & 77 Reamer's Road		
Subdivision, Lot #			
<b>OWNER/APPLICANT INFORMATION</b>		I have inspected the installation authorized above and found it to be in compliance with the Subsurface Wastewater Disposal Rules Application.	
Name (last, first, MI)	Bardel, Britton, and Sharp		
Mailing Address of Owner/Applicant	Howard, Robert C Box 35, Cliff Island, ME 04019		
Daytime Tel. #	207-766-2850		
OWNER OR APPLICANT STATEMENT I state and acknowledge that the information submitted is correct to the best of my knowledge and understand that any falsification is reason for the Department and/or Local Plumbing Inspector to deny a Permit.		CAUTION: INSPECTION REQUIRED I have inspected the installation authorized above and found it to be in compliance with the Subsurface Wastewater Disposal Rules Application.	
Signature of Owner or Applicant: <u>[Signature]</u> Date: <u>5/13/14</u>		(1st) date approved: _____ Local Plumbing Inspector Signature: <u>[Signature]</u> (2nd) date approved: _____	

PERMIT INFORMATION			
<b>TYPE OF APPLICATION</b> <input type="checkbox"/> 1. First Time System <input checked="" type="checkbox"/> 2. Replacement System Type replaced: <u>Overboard Disc.</u> Year installed: _____ <input type="checkbox"/> 3. Expanded System <input type="checkbox"/> a. <25% Expansion <input type="checkbox"/> b. >= 25% Expansion <input type="checkbox"/> 4. Experimental System <input type="checkbox"/> 5. Seasonal Conversion	<b>THIS APPLICATION REQUIRES</b> <input checked="" type="checkbox"/> 1. No Rule Variance <input type="checkbox"/> 2. First Time System Variance <input type="checkbox"/> a. Local Plumbing Inspector Approval <input type="checkbox"/> b. State & Local Plumbing Inspector <input type="checkbox"/> 3. Replacement System Variance <input type="checkbox"/> a. Local Plumbing Inspector Approval <input type="checkbox"/> b. State & Local Plumbing Inspector <input type="checkbox"/> 4. Minimum Lot Size Variance <input type="checkbox"/> 5. Seasonal Conversion Permit	<b>DISPOSAL SYSTEM COMPONENTS</b> <input checked="" type="checkbox"/> 1. Complete Non-engineered System <input type="checkbox"/> 2. Primitive System (graywater & alt. toilet) <input type="checkbox"/> 3. Alternative Toilet, specify: _____ <input type="checkbox"/> 4. Non-engineered Treatment Tank (only) <input type="checkbox"/> 5. Holding Tank, _____ gallons <input type="checkbox"/> 6. Non-engineered Disposal Field (only) <input type="checkbox"/> 7. Separated Laundry System <input type="checkbox"/> 8. Complete Engineered System (2000 gpd or more) <input type="checkbox"/> 9. Engineered Treatment Tank (only) <input type="checkbox"/> 10. Engineered Disposal Field (only) <input checked="" type="checkbox"/> 11. Pre-treatment, specify: <u>OxyPro or Equivalent</u> <input type="checkbox"/> 12. Miscellaneous Components	<b>DISPOSAL SYSTEM TO SERVE</b> <input type="checkbox"/> 1. Single Family Dwelling Unit, No. of Bedrooms: _____ <input type="checkbox"/> 2. Multiple Family Dwelling, No. of Units: _____ <input checked="" type="checkbox"/> 3. Other: <u>multiple dwellings (8 bedrooms)</u> (specify) Current Use <input checked="" type="checkbox"/> Seasonal <input type="checkbox"/> Year Round <input type="checkbox"/> Undeveloped
<b>SIZE OF PROPERTY</b> +-1.5 <input type="checkbox"/> SQ. FT. <input checked="" type="checkbox"/> ACRES	<b>TYPE OF WATER SUPPLY</b> <input checked="" type="checkbox"/> 1. Drilled Well <input type="checkbox"/> 2. Dug Well <input type="checkbox"/> 3. Private <input type="checkbox"/> 4. Public <input type="checkbox"/> 5. Other		
<b>SHORELAND ZONING</b> <input checked="" type="checkbox"/> Yes <input type="checkbox"/> No			

DESIGN DETAILS (SYSTEM LAYOUT SHOWN ON PAGE 3)			
<b>TREATMENT TANK</b> <input type="checkbox"/> 1. Concrete <input checked="" type="checkbox"/> a. Regular <input type="checkbox"/> b. Low Profile <input checked="" type="checkbox"/> 2. Plastic <input type="checkbox"/> 3. Other: _____ CAPACITY: <u>1,500</u> GAL	<b>DISPOSAL FIELD TYPE &amp; SIZE</b> <input type="checkbox"/> 1. Stone Bed <input type="checkbox"/> 2. Stone Trench <input checked="" type="checkbox"/> 3. Proprietary Device <input type="checkbox"/> a. cluster array <input type="checkbox"/> c. Linear <input checked="" type="checkbox"/> b. regular load <input type="checkbox"/> d. H-20 load <input type="checkbox"/> 4. Other: _____ SIZE: <u>720</u> <input type="checkbox"/> sq. ft. <input checked="" type="checkbox"/> lin. ft.	<b>GARBAGE DISPOSAL UNIT</b> <input checked="" type="checkbox"/> 1. No <input type="checkbox"/> 2. Yes <input type="checkbox"/> 3. Maybe If Yes of Maybe, specify one below: <input type="checkbox"/> a. multi-compartment tank <input type="checkbox"/> b. ___ tanks in series <input type="checkbox"/> c. increase in tank capacity <input type="checkbox"/> d. Filter on Tank Outlet	<b>DESIGN FLOW</b> <u>764</u> gallons per day BASED ON: <input checked="" type="checkbox"/> 1. Table 4A (dwelling unit(s)) <input type="checkbox"/> 2. Table 4C (other facilities) SHOW CALCULATIONS --- for other facilities ---
<b>SOIL DATA &amp; DESIGN CLASS</b> PROFILE <u>2</u> / <u>AIII</u> / _____ at Observation Hole # <u>TP-1</u> Depth <u>20</u> " of Most Limiting Soil Factor Bedrock	<b>DISPOSAL FIELD SIZING</b> <input type="checkbox"/> <input type="checkbox"/> 2. Medium—2.6 sq. ft. / gpd <input checked="" type="checkbox"/> 3. Medium—Large 3.3 sq. ft. / gpd <input type="checkbox"/> 4. Large—4.1 sq. ft. / gpd <input type="checkbox"/> 5. Extra Large—5.0 sq. ft. / gpd	<b>EFFLUENT/EJECTOR PUMP</b> <input type="checkbox"/> 1. Not Required <input type="checkbox"/> 2. May Be Required <input checked="" type="checkbox"/> 3. Required Specify only for engineered systems: DOSE: _____ gallons	<input type="checkbox"/> 3. Section 4G (meter readings) ATTACH WATER METER DATA LATITUDE AND LONGITUDE at center of disposal area Lat. <u>N43</u> d <u>42</u> m <u>17.32</u> s Lon. <u>W70</u> d <u>06</u> m <u>02.64</u> s if g.p.s. state margin of error: <u>20'</u>

SITE EVALUATOR STATEMENT		
I certify that on <u>8-18-09</u> (date) I completed a site evaluation on this property and state that the data reported are accurate and that the proposed system is in compliance with the State of Maine Subsurface Wastewater Disposal Rules (10-144A CMR 241).		
<u>[Signature]</u> Site Evaluator Signature	<u>034</u> SE #	<u>12/31/13</u> Date
Richard A. Sweet Site Evaluator Name Printed	797-2110 Telephone Number	dick@sweetassociates.com Email Address
Note: Changes to or deviations from the design should be confirmed with the Site Evaluator.		

# SUBSURFACE WASTEWATER DISPOSAL SYSTEM APPLICATION

Maine Department of Human Services  
Division of Health Engineering, Station 10  
(207) 287-5672 Fax: (207) 287-3165

Town, City, Plantation  
**Portland (Cliff Island)**

Street, Road, Subdivision  
**62, 68, & 77 Reamer's Road**

Owner or Applicant Name  
**Bardel, Britton, and Sharp**

## SUBSURFACE WASTEWATER DISPOSAL PLAN

Scale: 1" = 20' ft

Existing Grade Elevations	
-37"	-39"
-43"	-39"
FIELD CORNERS	

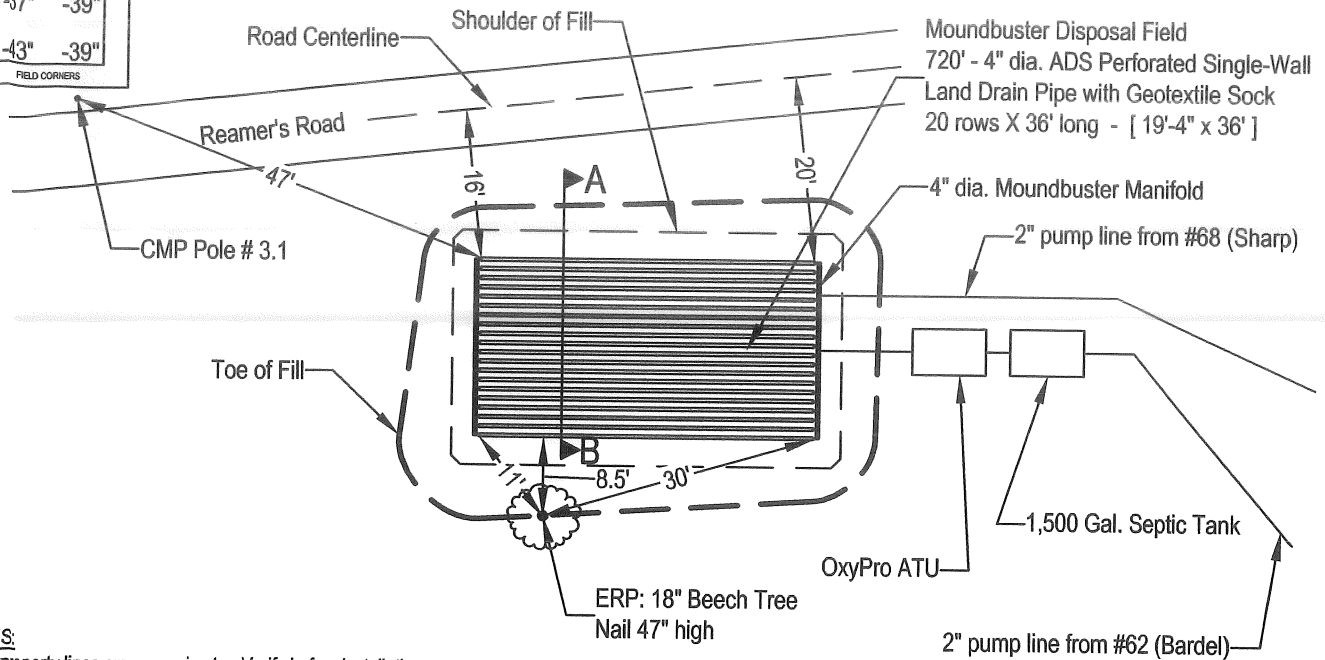

**NOTES:**

1. All property lines are approximate. Verify before installation.
2. A septic easement is required prior to obtaining approval from Local Plumbing Inspector.
3. Scarify all ground to be filled.
4. A 2" dia. pressure line shall connect to both pump stations.
4. Line connections into Moundbuster manifold must not be opposite drain lines.

**BACKFILL REQUIREMENTS**

Depth of Backfill (upslope) 10-12"  
Depth of Backfill (downslope) 16-12"

**CONSTRUCTION ELEVATIONS**

Finished Grade Elevation (at Row 1) -27"  
Top of Proprietary Device (at Row 1) -35"  
Bottom of Disposal Field (at Row 1) -39"

**ELEVATION REFERENCE POINT**

Location & Description: 18" Beech Tree Nail 47" high

Reference Elevation is 0.0" or: \_\_\_\_\_

NOTE: SCARIFY ALL GROUND SURFACE TO BE FILLED. USE SPECIFIED MOUNDBUSTER FILL. REMAINING FILL: LOAMY SAND (no clay)

**DISPOSAL FIELD CROSS SECTION**

APPROXIMATE ABOVE GRADE FILL REQUIRED  
27 cubic yards of LOAM  
40 cubic yards of SAND  
Volume of chambers not considered

Scales:

Vertical: 1" = 5'  
Horizontal: 1" = 5'

ROW #	1	2	3	4	5	6	7	8	9	10	11	12	13	14	15	16	17	18	19	20
TOP	-35"	-35"	-35"	-35"	-35"	-35"	-35"	-35"	-35"	-35"	-35"	-35"	-35"	-35"	-35"	-35"	-35"	-35"	-35"	-35"
BOTTOM	-39"	-39"	-39"	-39"	-39"	-39"	-39"	-39"	-39"	-39"	-39"	-39"	-39"	-39"	-39"	-39"	-39"	-39"	-39"	-39"

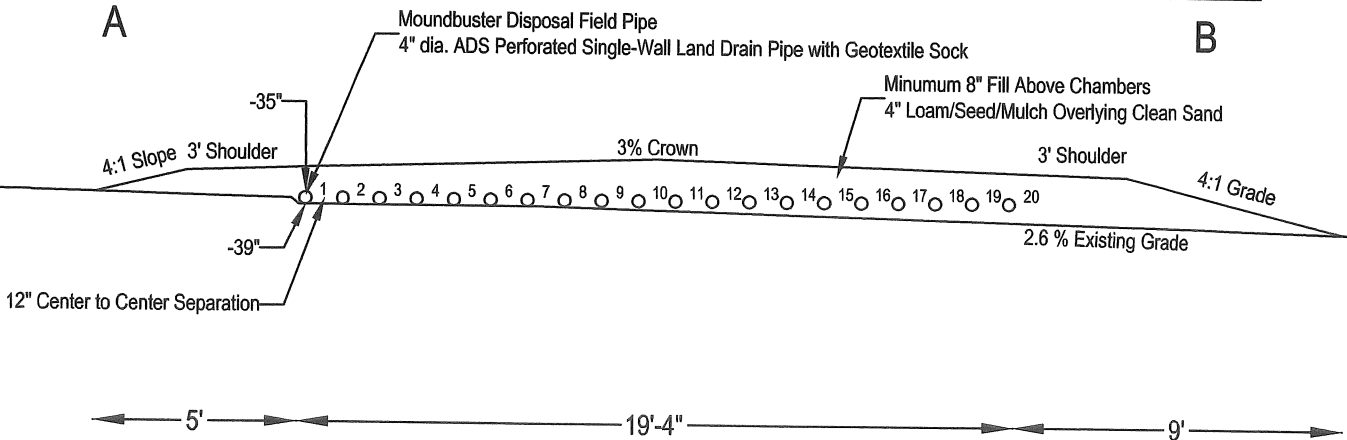

*Richard O'Connell*  
Site Evaluator Signature

034  
SE #

12/31/13  
Date





**SEPTIC EASEMENT AGREEMENT, JUNE 2015**

**WHEREAS** the undersigned owners of parcels on Cliff Island, Maine:

**Marcia and Larry Sharp, owning land designated on current Portland tax rolls as No. 54- 58 Reamer's Road (formerly numbered #68) ;**

**Penelope and William Bardel, owning land designated on current Portland tax rolls as No. 62 Reamer's Road; and**

**Florence K. Britton, owning land designated on current Portland tax rolls as No. 68 Reamer's Road (formerly numbered #77),**

**wish to install a Subsurface Wastewater Disposal system ("the system"), to serve parcels No. 54-58 and No. 62; and**

**WHEREAS** there is no plumbing on Parcel No. 68; and

**WHEREAS** William and Penelope Bardel on or about October 1, 2009 submitted a Permit Application, HHE-200, for installation of the proposed system on behalf of all of the undersigned, said application containing on page 2 thereof a map (copy attached) showing each of these parcels in relation to the proposed system; and

**WHEREAS** the center of the disposal field for the proposed system will be located at Lat. N43 d42 m17.32 s; Lon W70 d06 m2.64s; and the disposal area itself therefore situated partly on parcel No. 68, and partially on parcel No. 62, again as shown on the aforementioned map; and

**WHEREAS** it will be necessary to lay pipe from one pump station (former chlorinator) on parcel No. 54-58 to the disposal field, and another from a second pump station (former chlorinator) on parcel No. 62, said pipes to run across portions of each of parcels 54-58, 62, and parcel 68, to reach the aforementioned disposal field,

**NOW THEREFORE,** each of the undersigned grants to each of the others undersigned, and to their heirs, successors and assigns, a right of easement to lay and maintain lines of pipe for carriage of

septic fluid over and through their respective parcels to connect to the  
aforementioned disposal field; and

FURTHER grants to each of the other undersigneds the right to enter  
upon any of parcels 54-58, 62 and/or 68 for the purpose of servicing,  
maintaining, repairing or replacing any parts of the system requiring  
such attention at any time in the future; and

FURTHER agrees each to record this Septic Easement Agreement  
with the deed (-s) to their respective parcel as a condition precedent  
to a permit being issued by the Local Plumbing Inspector for  
installation of the system.

IN WITNESS WHEREOF we have each signed as below

*Marcia K Sharp*

Marcia K Sharp  
Parcel 54-58 (formerly #68 on map)  
Date:

State of Maine  
County of Cumberland

The foregoing instrument was acknowledged before me this 18<sup>th</sup> day of June, 2015,  
at Yarmouth, ME, by Marcia K. Sharp to be his/her free  
act and deed.

Signature of Notary Public *[Signature]*  
Name of Notary Public Elizabeth L. Rogers

SEAL  
Notary Public, State of Maine  
My commission expires: July 13, 2017

*[Handwritten Signature]*

Larry D Sharp  
Parcel 54-58 (formerly #68 on map)  
Date:

State of Maine  
County of Cumberland

The foregoing instrument was acknowledged before me this 18<sup>th</sup> day of June, 2015,  
at Yarmouth, ME, by Larry D. Sharp to be his/her free  
act and deed.

Signature of Notary Public *[Signature]*  
Name of Notary Public Elizabeth L. Rogers

SEAL  
Notary Public, State of Maine  
My commission expires: July 13, 2017

Penelope K. Bardel  
Penelope K. Bardel

Penelope K Bardel  
Parcel 62  
Date:

State of Connecticut  
County of Litchfield

The foregoing instrument was acknowledged before me this 11<sup>th</sup> day of June, 2015,  
at Washington Dept., by Penelope K Bardel to be his/her free  
act and deed.

Signature of Notary Public *[Signature]*  
Name of Notary Public Debra L. Swift NOTARY PUBLIC

SEAL  
Notary Public, State of Connecticut  
My commission expires: 4/30/2016  
My Commission Expires  
April 30, 2016

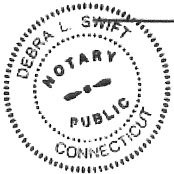

William G. Bardel  
William G. Bardel

Doc#: 28842 Bk:32362 Pg: 341

William G. Bardel  
Parcel 62  
Date:

State of Connecticut  
County of Hitchcock

The foregoing instrument was acknowledged before me this 11<sup>th</sup> day of June, 2015,  
at Washington Depot by William G. Bardel to be his/her free  
act and deed.

Signature of Notary Public [Signature]  
Name of Notary Public Debra L. Swift

SEAL  
Notary Public, State of Connecticut  
My commission expires: My Commission Expires April 30, 2016

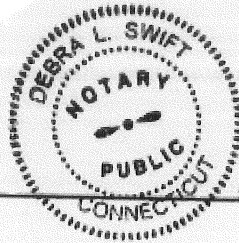

Florence K Britton  
Parcel 68 (formerly #77 on map)  
Date:

State of \_\_\_\_\_  
County of \_\_\_\_\_

The foregoing instrument was acknowledged before me this \_\_\_\_\_ day of \_\_\_\_\_, 20\_\_\_\_,  
at \_\_\_\_\_, by \_\_\_\_\_ to be his/her free  
act and deed.

Signature of Notary Public \_\_\_\_\_  
Name of Notary Public \_\_\_\_\_

SEAL  
Notary Public, State of \_\_\_\_\_  
My commission expires: \_\_\_\_\_

### SUBSURFACE WASTEWATER DISPOSAL SYSTEM APPLICATION

Town, City, Parish <b>Portland (Cliff Island)</b>	Street, Road, Subdivision <b>#62, #68, &amp; #77 Reamer's Road</b>	Public Department of Health Services Division of Health Engineering, Section 40 (202) 281-5870 Fax: (202) 281-3165
Owner or Applicant Name <b>Penelope Bardel</b>		

**SITE PLAN**

Scale 1" = 60' R.

**SITE LOCATION PLAN**

**SOIL PROFILE DESCRIPTION AND CLASSIFICATION**  
(Location of Observation Holes Shown Above)

Observation Hole # TB-1  Test Pit  Boring

Depth of organic horizon above mineral soil

Texture	Consistency	Color	Mottling
0			
6			
12	Sandy loam	Frable	Reddish Brown
18			
24			
30			
36			
42			
48			

Depth below mineral soil surface (inches)

Soil Profile	Classification	Shade	Limiting Factor	Groundwater
<u>2</u>	<u>All</u>	<u>2</u>	<u>20"</u>	<input type="checkbox"/>
	Condition	Percent	Depth	<input type="checkbox"/> Restrictive Layer
				<input checked="" type="checkbox"/> Bedrock

Observation Hole # \_\_\_\_\_  Test Pit  Boring

Depth of organic horizon above mineral soil

Texture	Consistency	Color	Mottling
0			
6			
12			
18			
24			
30			
36			
42			
48			

Depth below mineral soil surface (inches)

Soil Profile	Classification	Shade	Limiting Factor	Groundwater
				<input type="checkbox"/>
	Condition	Percent	Depth	<input type="checkbox"/> Restrictive Layer
				<input type="checkbox"/> Bedrock

*Richard Chant*  
Site Evaluator Signature

034  
SB #

09/24/09  
Date

Page 2 of 3  
HHE-200 Rev. 10/02

William G. Bardel

Parcel 62

Date:

State of \_\_\_\_\_  
County of \_\_\_\_\_

The foregoing instrument was acknowledged before me this \_\_\_\_\_ day of \_\_\_\_\_, 20\_\_\_\_,  
at \_\_\_\_\_, by \_\_\_\_\_, to be his/her free  
act and deed.

Signature of Notary Public \_\_\_\_\_  
Name of Notary Public \_\_\_\_\_

SEAL  
Notary Public, State of \_\_\_\_\_  
My commission expires: \_\_\_\_\_

*Florence K. Britton*

Florence K Britton

Parcel 68 (formerly #77 on map)

Date: *June 13, 2015*

State of \_\_\_\_\_  
County of \_\_\_\_\_

The foregoing instrument was acknowledged before me this \_\_\_\_\_ day of \_\_\_\_\_, 20\_\_\_\_,  
at \_\_\_\_\_, by \_\_\_\_\_, to be his/her free  
act and deed.

Signature of Notary Public \_\_\_\_\_  
Name of Notary Public \_\_\_\_\_

SEAL  
Notary Public, State of \_\_\_\_\_  
My commission expires: \_\_\_\_\_

PLEASE SEE  
NOTARY ATTACHMENT

CALIFORNIA ALL-PURPOSE ACKNOWLEDGMENT

CIVIL CODE § 1189

A notary public or other officer completing this certificate verifies only the identity of the individual who signed the document to which this certificate is attached, and not the truthfulness, accuracy, or validity of that document.

State of California )
County of SAN MATEO )
On 6/13/15 before me, STEVEN A. WAGNER, NOTARY PUBLIC,
Date Here Insert Name and Title of the Officer
personally appeared FLORENCE K. BREZINA
Name(s) of Signer(s)

who proved to me on the basis of satisfactory evidence to be the person(s) whose name(s) is/are subscribed to the within instrument and acknowledged to me that he/she/they executed the same in his/her/their authorized capacity(ies), and that by his/her/their signature(s) on the instrument the person(s), or the entity upon behalf of which the person(s) acted, executed the instrument.

I certify under PENALTY OF PERJURY under the laws of the State of California that the foregoing paragraph is true and correct.

WITNESS my hand and official seal.

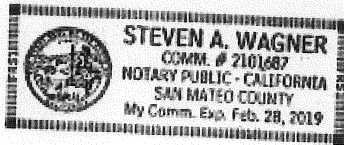

Signature [Handwritten Signature]
Signature of Notary Public

Place Notary Seal Above

OPTIONAL

Though this section is optional, completing this information can deter alteration of the document or fraudulent reattachment of this form to an unintended document.

Description of Attached Document AGREEMENT
Title or Type of Document: SETBACK INSTRUMENT Document Date: 6/13/15
Number of Pages: 4 Signer(s) Other Than Named Above:

Capacity(ies) Claimed by Signer(s)
Signer's Name:
[ ] Corporate Officer - Title(s):
[ ] Partner - [ ] Limited [ ] General
[ ] Individual [ ] Attorney in Fact
[ ] Trustee [ ] Guardian or Conservator
[ ] Other:
Signer Is Representing:



