

19 WINDOW HORIZONTAL MULLION DETAIL  
6"=1'-0"

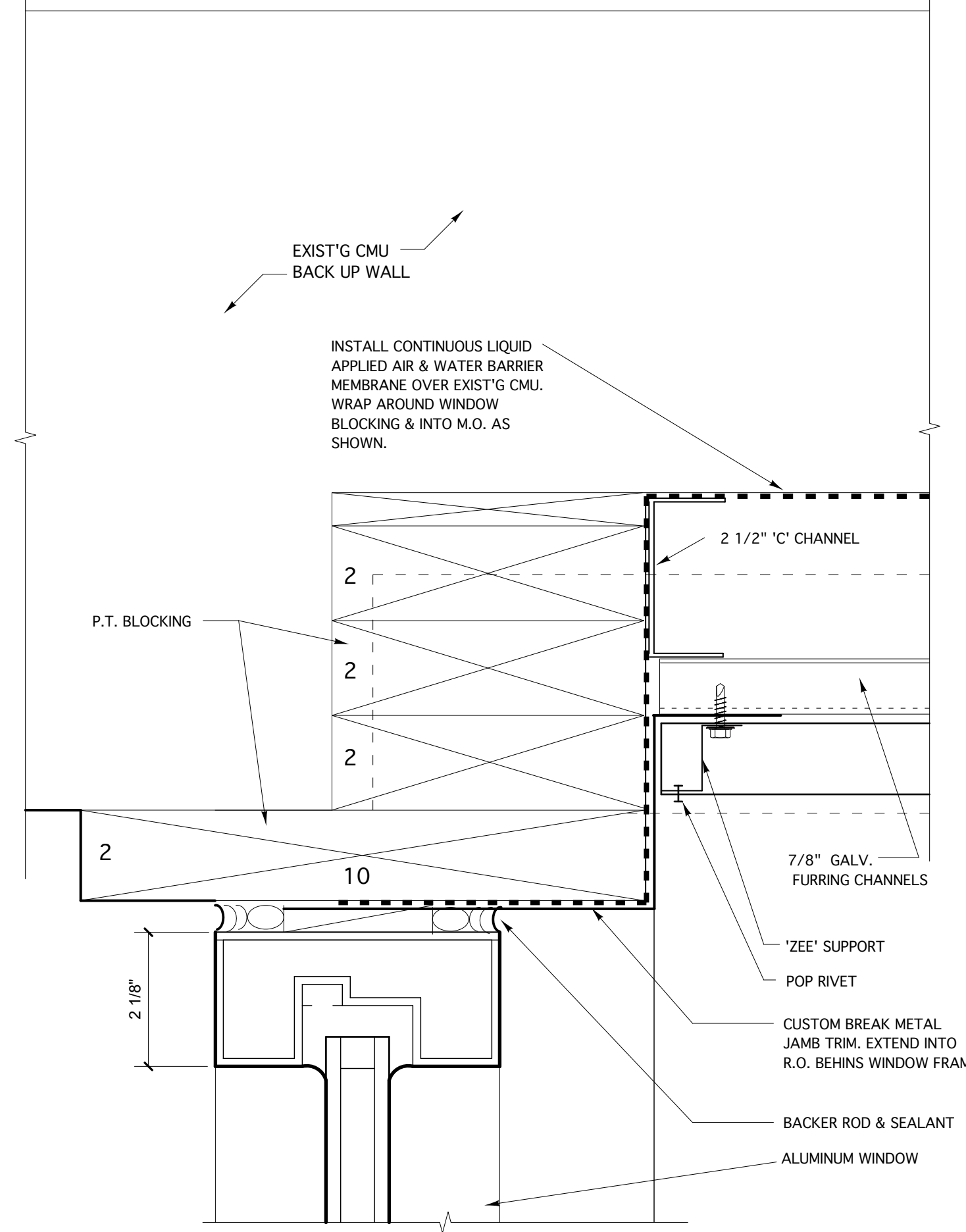

17 WINDOW JAMB DETAIL  
6"=1'-0"

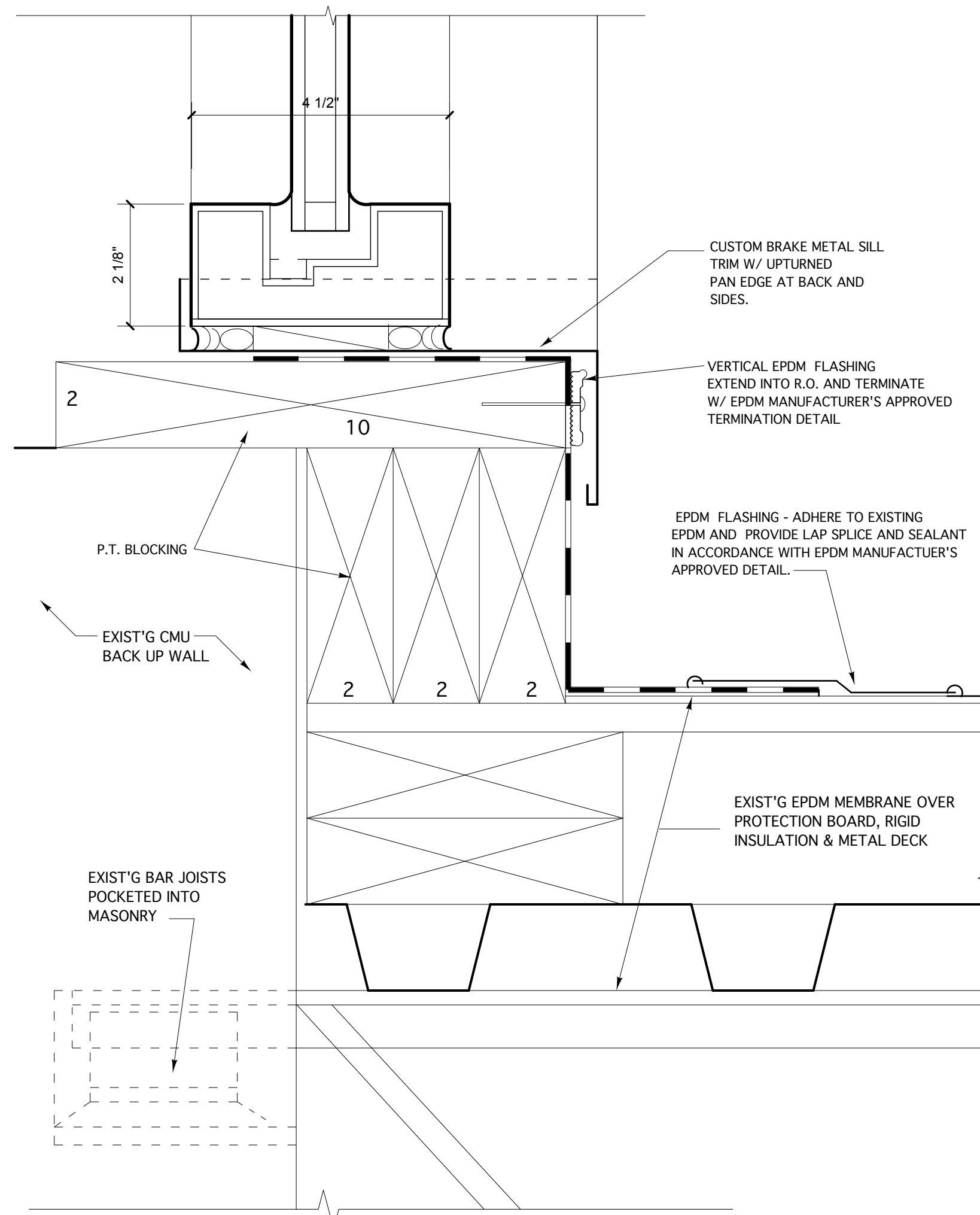

18 WINDOW SILL DETAIL  
6"=1'-0"

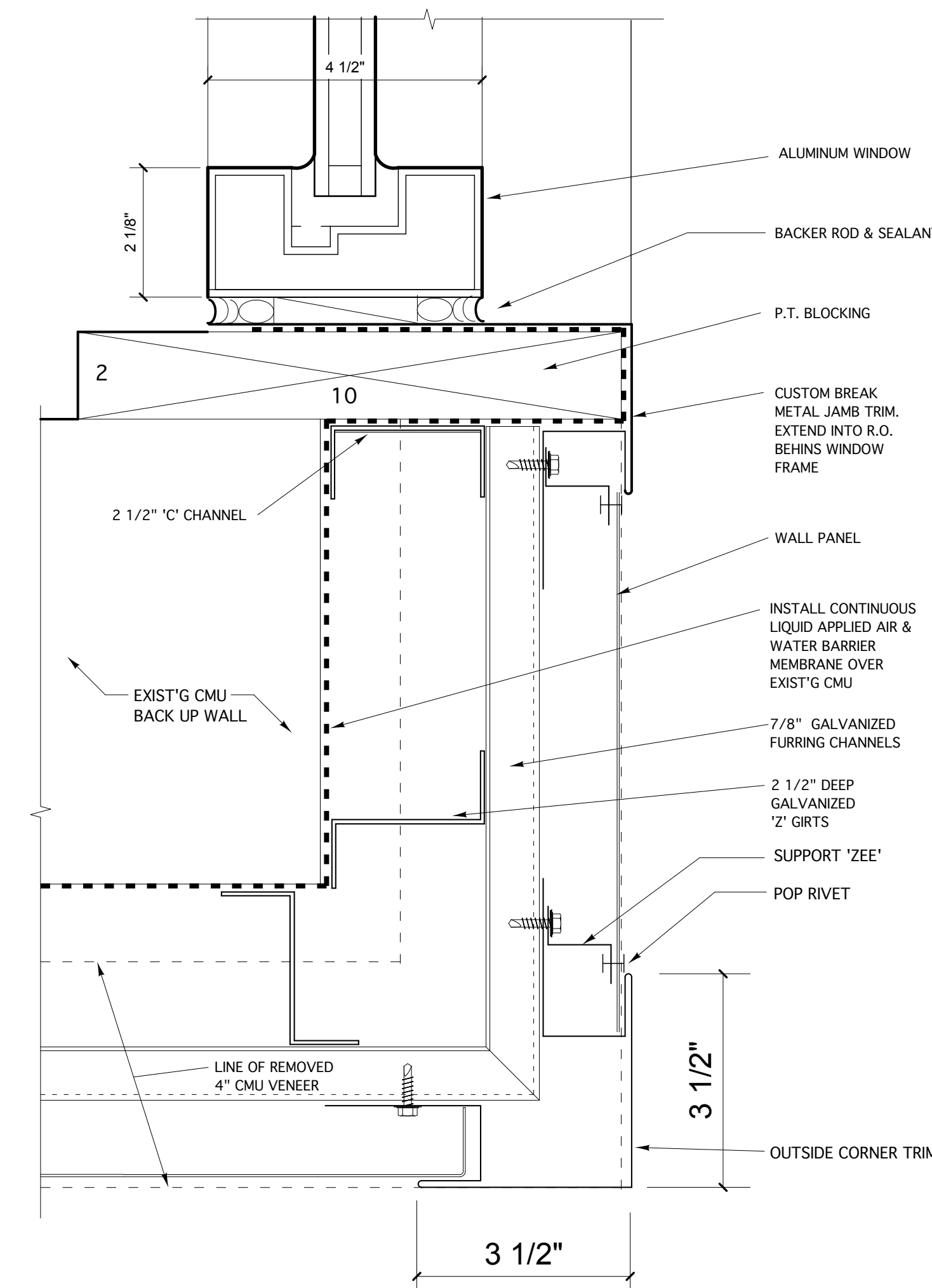

16 WINDOW JAMB DETAIL  
6"=1'-0"

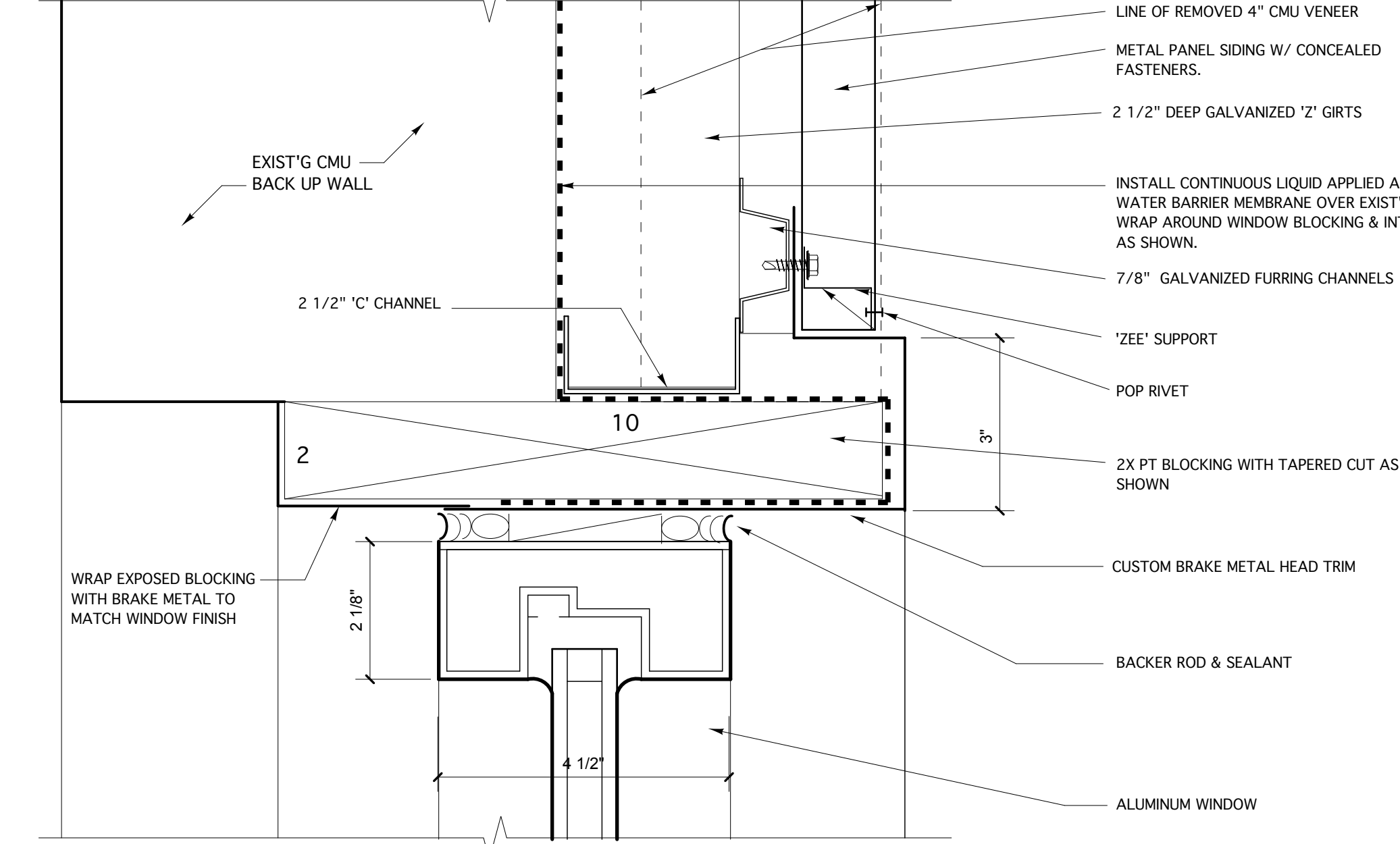

15 WINDOW HEAD DETAIL  
6"=1'-0"

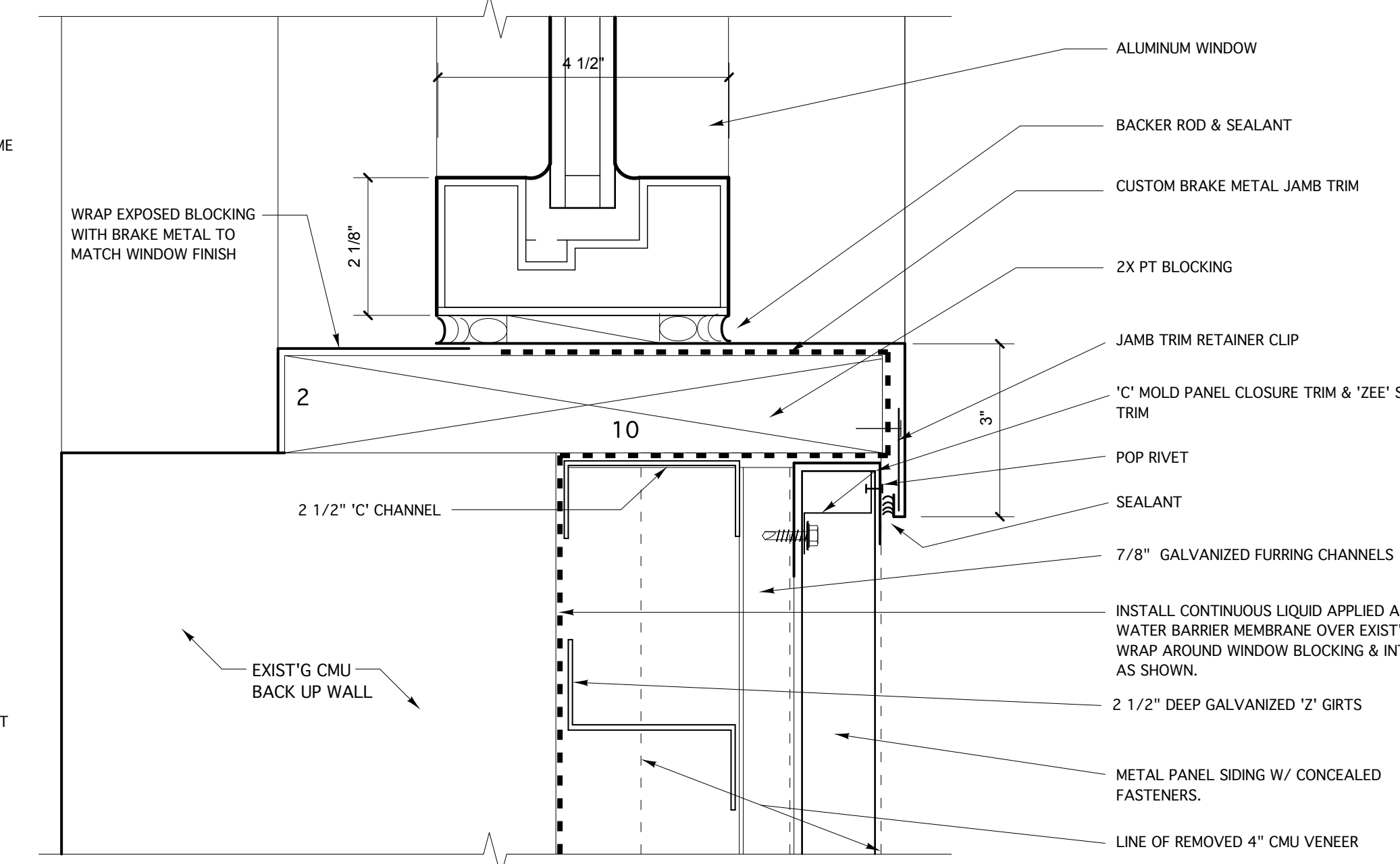

14 WINDOW JAMB DETAIL  
6"=1'-0"

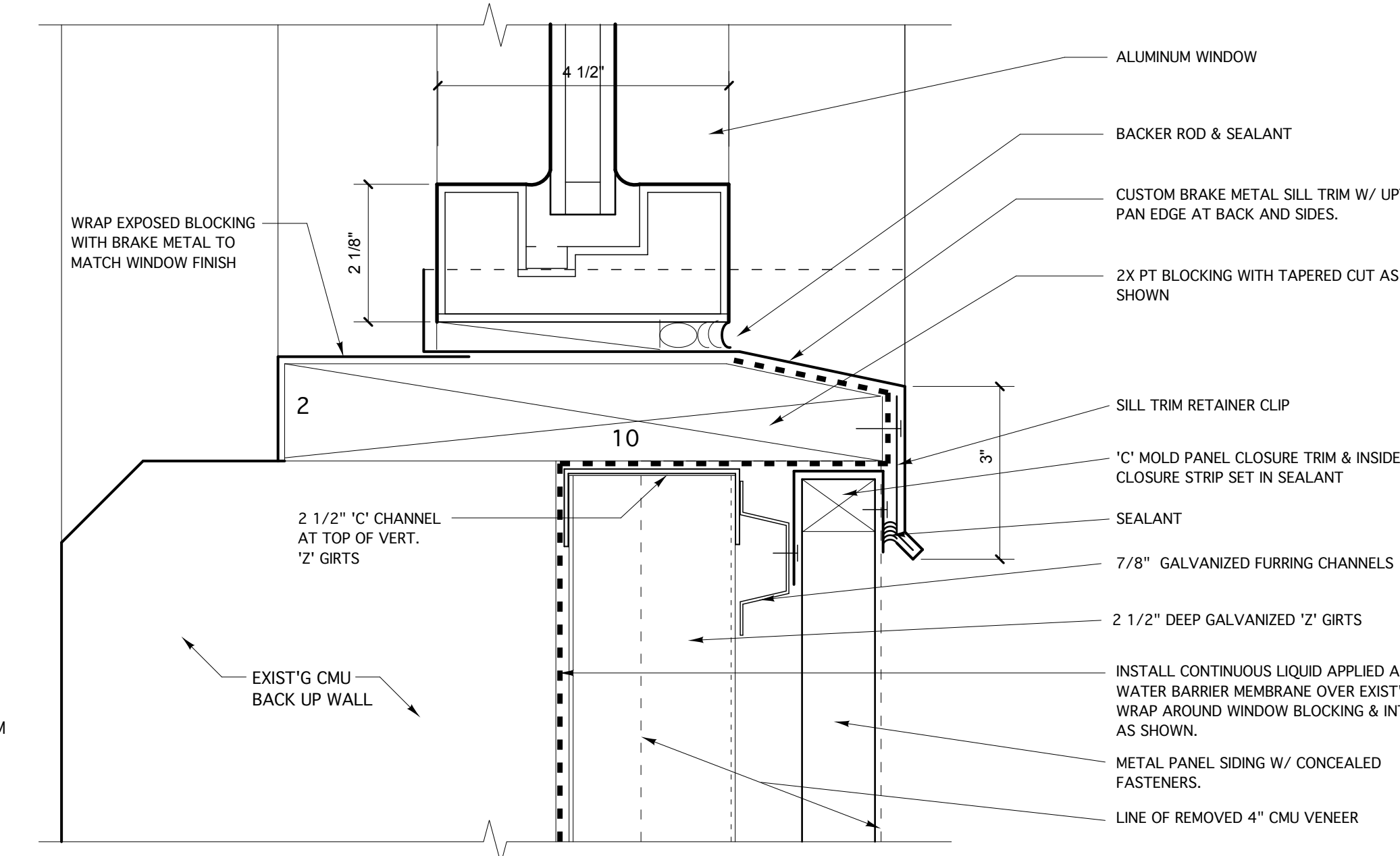

13 WINDOW SILL DETAIL  
6"=1'-0"

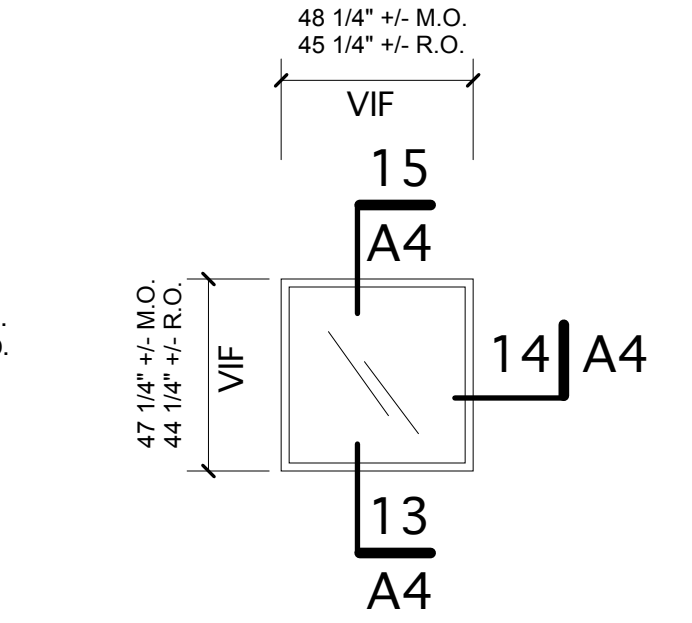

1 FIXED FRAME UNIT  
13 Units Req'd

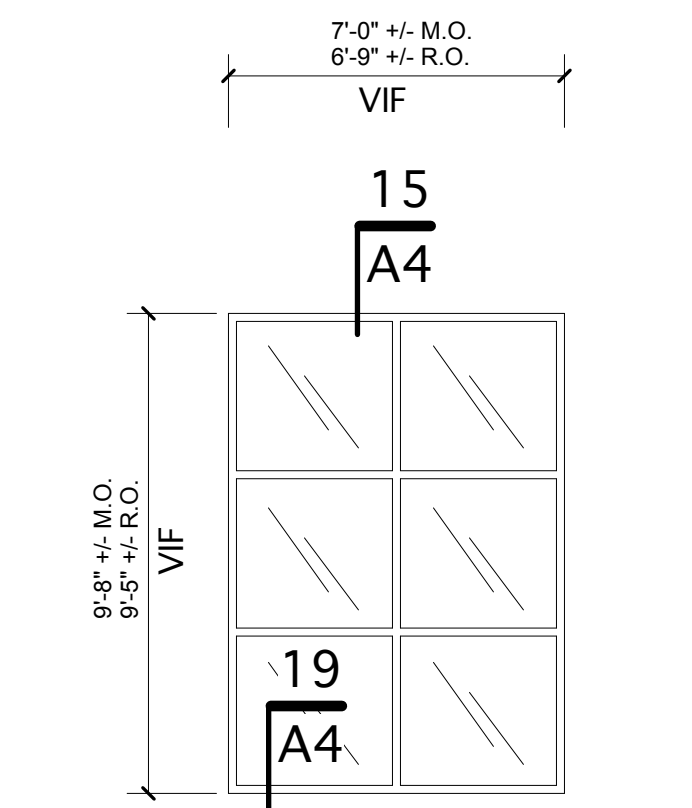

16 FIXED FRAME UNIT  
16 Units Req'd

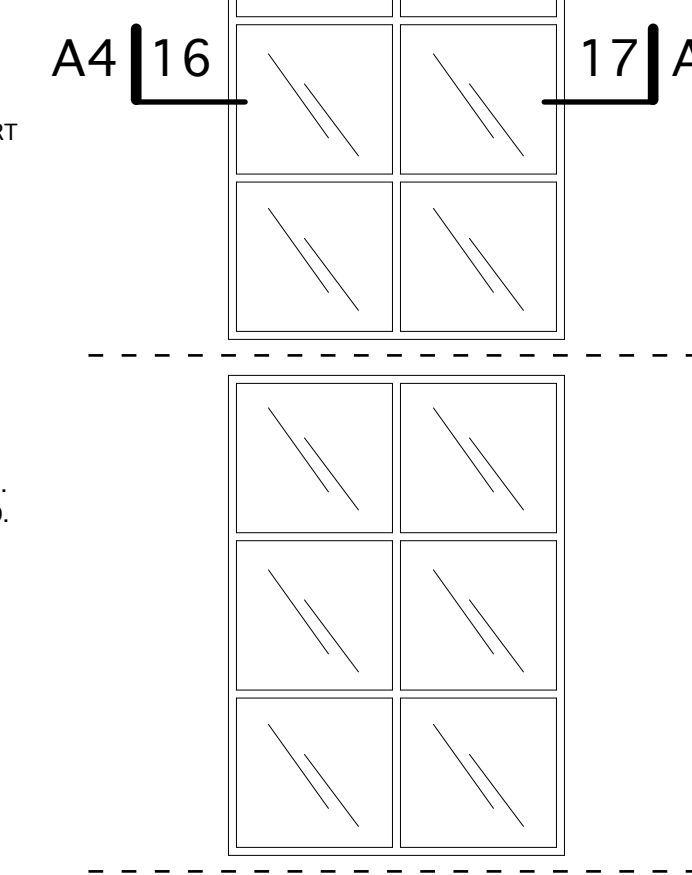

17 FIXED FRAME UNIT  
17 Units Req'd

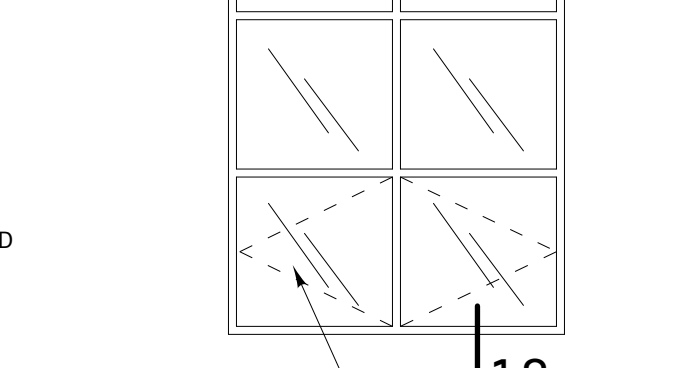

18 FIXED FRAME UNIT  
18 Units Req'd

2 FIXED FRAME UNIT  
(Mulled in Field)  
4 Units Req'd

INTENT IS TO MATCH DIMENSIONS AND MULLION SPACING OF EXISTING

WINDOW TYPES  
1/4"=1'-0"