

Will Conway

From: Shields, Myron <mshields@DuramaxMarine.com>
Sent: Thursday, May 07, 2015 5:52 AM
To: Ian MacDonald
Cc: Will Conway; James Gauthier
Subject: RE: NEOCH Keel Coolers - DEP
Attachments: DuraCooler Installation 12-20-2012 (S).pdf; DURACooler brochure 07-16-2007 (S).pdf

Hi Ian,

I spoke to management and we have zero history and or any documented complaints concerning the DEP. The keel coolers are an engineered product. All hand brazed together, vibration and pressure checked prior to delivery to a customer.

The 90-10 copper –nickel material is designed to allow efficient thermal heat transfer and to resist water flow erosion and biological growth.

These are typically installed on every type of vessel that you can imagine throughout the world. As far as a thermal threat, I don't see how these would affect the Casco Bay harbor with cold water pretty much year round and tidal flow.

A potential leak would only be a concern in my mind if these were mounted on a vessel and not protected as we show in the brochure. Mounting them in water on a structure such as a pier with protection would be safe I believe.

Please let me know if you need other information or have additional questions.

Please see attached brochures for general cooler notes.

Regards

Myron

Myron Shields (USCG Retired)
Duramax Marine LLC
Sales Manager/Government Sales-East Coast
Office: 207-676-1181 Fax: 207-676-1181
Mobile: 440-364-7981
mshields@duramaxmarine.com
www.duramaxmarine.com

From: Ian MacDonald [mailto:imacdonald@allied-eng.com]
Sent: Wednesday, May 06, 2015 8:06 AM
To: Shields, Myron
Cc: Will Conway; James Gauthier
Subject: NEOCH Keel Coolers - DEP

Hello,

Has Duramax ever had to deal with DEP environmental issues relating to keel coolers?

DuraCooler® Keel Cooler

- ▷ Streamlined Header Design for Improved Efficiency
- ▷ One Piece 90/10 Copper-Nickel Construction
- ▷ Superior Heat Transfer

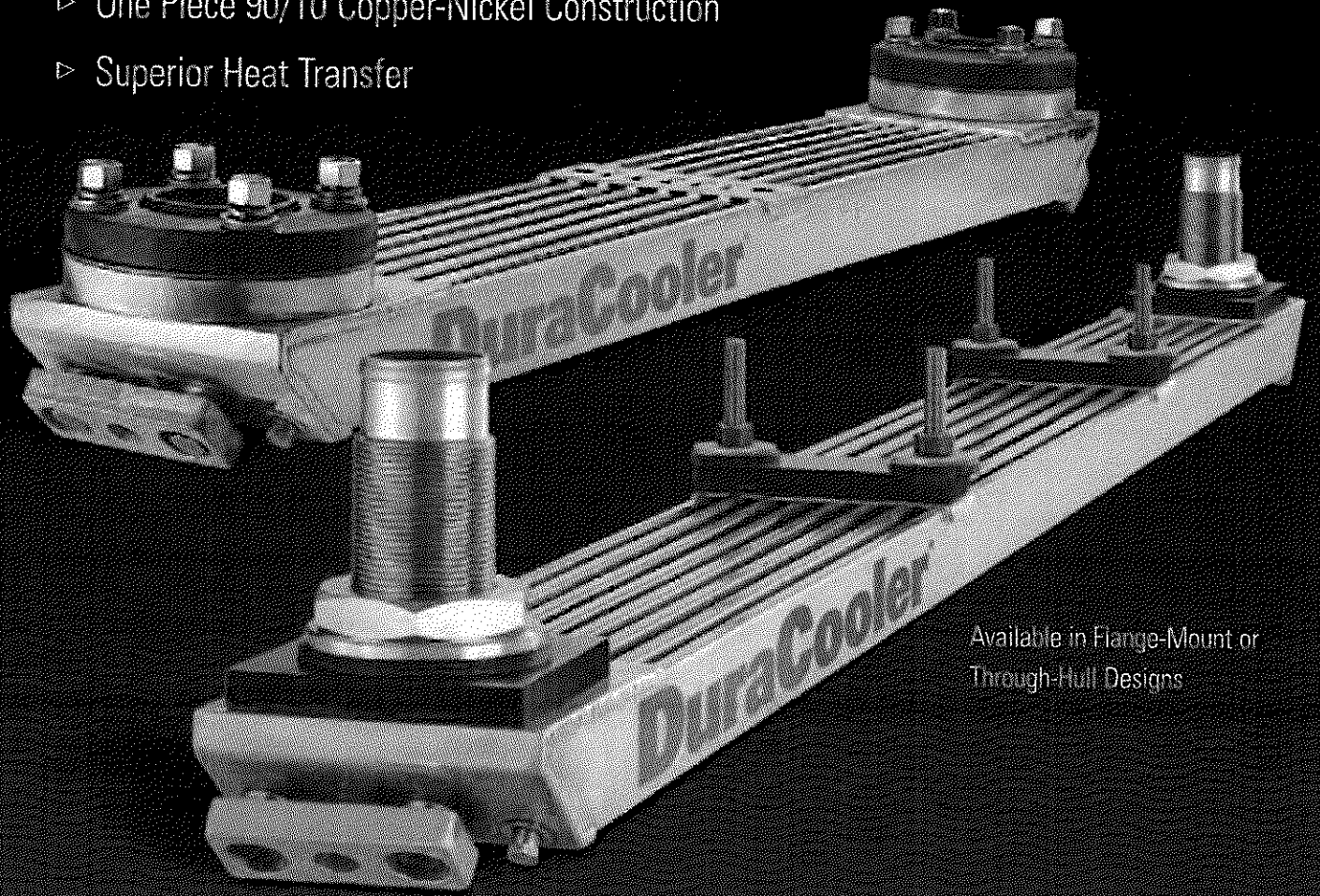

Available in Flange-Mount or
Through-Hull Designs

PRODUCT INFORMATION AND SELECTION GUIDE

DURAMAX MARINE®

DuraCoolers® With Streamlined Header Design Significantly Increases Heat Transfer Efficiency.

Duramax Marine® conducted extensive research to identify opportunities to improve the operational efficiency of the traditional square-header keel cooler.

Through finite element computer studies, we discovered the traditional square-header keel cooler design caused certain inefficiencies. Full-scale tests were conducted to determine internal and external flow patterns, system pressure loss and heat transfer characteristics for different heat exchanger geometries.

It was discovered that the outside tubes of the keel cooler have the greater potential for heat rejection per lineal foot but due to internal geometry this potential was not being realized.

(See test results on next page.)

Advantages of the DuraCooler® streamlined header design.

- Enhanced interior and exterior flow patterns
- Reduced pressure drop
- Increased heat transfer efficiency
- Greatly increased heat rejection in outside tubes
- Provides better fuel efficiency due to less drag
- Deflects debris away from cooler

DuraCooler® applications.

The DuraCooler® is engineered to cool main and auxiliary diesel engines for wooden, steel and fiberglass hulled applications. It is used around the world on tugs, push boats, offshore supply vessels (OSV), crew boats, fishing vessels, pilot boats, research vessels, ferries, and many other vessel types.

All DuraCoolers® are custom engineered to meet the specific cooling requirements of the engine manufacture and the operating conditions of the vessel.



Full-Scale Tested DuraCooler® Design improves flow patterns.

Overall heat transfer in the DuraCooler® increased by 17%.

The patented streamlined header design enhances interior coolant and exterior seawater flow patterns while reducing system pressure drop within the keel cooler unit.

This translates into improved heat transfer efficiency.

▶ **Coolant flow distribution to the outside tubes increased 35%**

▶ **Heat rejection in the outer tubes increased 45%**

NOTE: Study conducted by Flow Simulations Inc. on a SC-48-96 and equivalent size square-head unit.

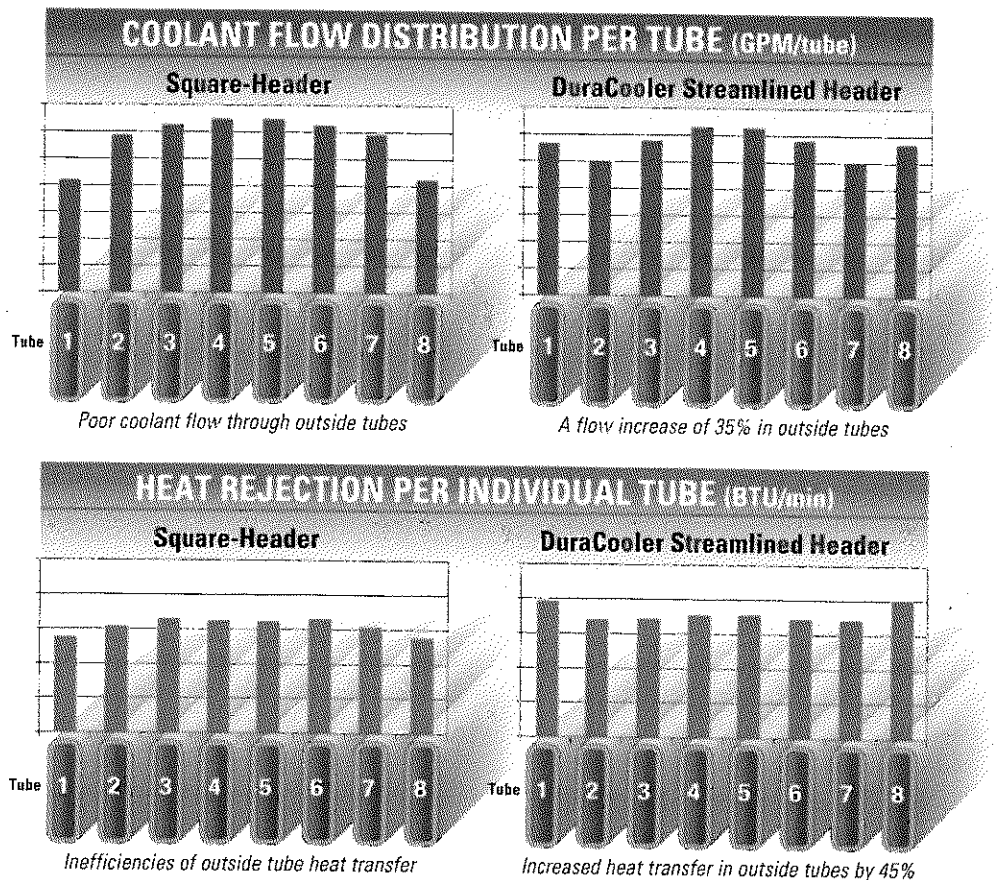

Smaller footprint reduces cooling system costs.

The DuraCooler® streamlined design, with increased coolant flow to the outside tubes, reduces the footprint versus the original square head design. It can be easily retrofitted to cool auxiliary engines and other heat sources.

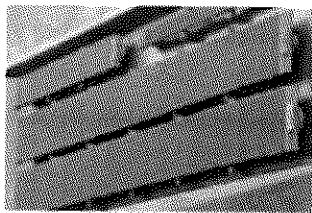

Trust Duramax Marine®. The heat exchange specialists.

For over 40 years, Duramax Marine® has been designing and manufacturing innovative heat exchange products for the commercial marine industry. A 800,000 gallon keel cooler test facility was constructed capable of testing full size keel coolers under various real world conditions — allowing us to optimize our keel cooler design and improved product.

Duramax Marine® has developed an exclusive computerized actual full-scale keel cooler sizing system based on test results. Our proprietary sizing system provides you with a correctly sized keel cooler for the intended application, reducing the risk of overheating.

So, have confidence knowing that you are working with a dedicated group of heat exchange professionals.

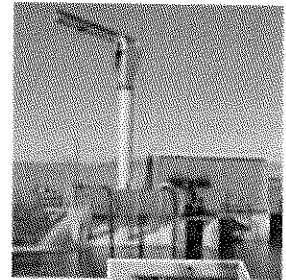

Through-Hull Nozzle Design

Manufactured for extreme durability and long life.

1 Nozzle design

Nozzle size and diameter is manufactured to fit your specific application.

2 Gaskets strategically sized and positioned

Designed to provide stand off from the hull, allowing water to pass the hull side of the DuraCooler® tubes with minimum interruption.

3 Streamlined header design

Significantly increases heat transfer efficiency over square-head design.

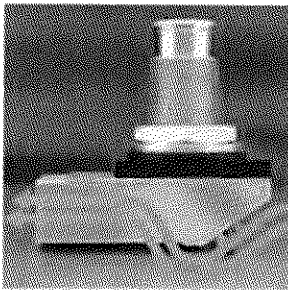

4 Two-piece header design

Allows for brazing on inside and outside of the header which, in turn, increases the integrity and reduces the chance of leakage.

Heavy-gauge material for headers

↳ Provides exceptional strength and durability.

Premium-grade silver solder

↳ Provides maximum strength, flexibility and leak resistance at all cooler joints.

↳ Every DuraCooler® is pressure and vibration tested to verify joint integrity.

5 Patented flow port

Exclusive, patented design of internal coolant flow port increases cooling performance of outside tubes.

6 Anodes mounted on beveled edge of header

Results in less stand-off distance from hull, less drag, better fuel efficiency. Also, they are less likely to be damaged by debris.

7 Rigid one-piece construction

Allows for easier installation and removal.

8 90/10 Copper-Nickel tubing

↳ High-strength material has excellent anti-fouling and heat transfer properties.

It also resists water-flow erosion.

↳ All tubes come in wall thickness of 0.062 inches.

Tubes come in three different sizes:

↳ #2 Tubes: 0.343" wide x 1.500" high.

↳ #3 Tubes: 0.500" wide x 1.687" high.

↳ #4 Tubes: 0.500" wide x 2.500" high.

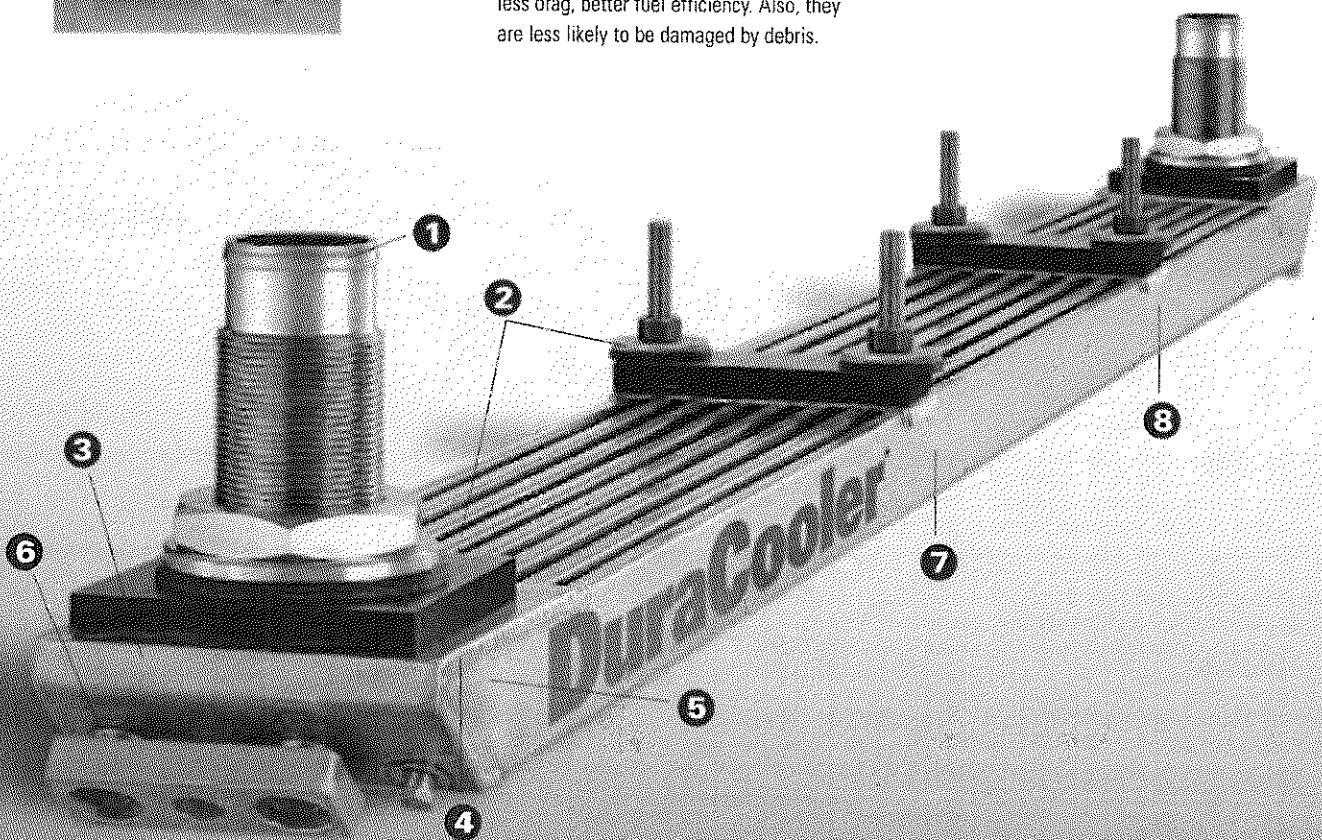
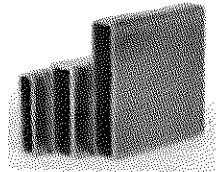

Flange-Mount Design

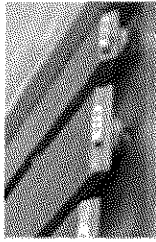

For non-through-hull applications.

With this DuraCooler® design there is no need for through-hull penetration. The flange-mount hardware is located outside the vessel where it is easy to access. This design is recommended when the inside area of the hull is tight or equipment makes the internal fittings on a standard through-hull inaccessible. The DuraCooler® Flange-Mount design and construction delivers the same optimum heat transfer as the Through-Hull design and can be custom fitted to your specific application.

No cofferdam or seachest saves space and money

Since fittings are outside the hull there is no need for a cofferdam or seachest, saving valuable space and installation costs.

Perfect for double hull designs

Standard through-hull nozzles may not be long enough to penetrate both hulls. The DuraCooler® Flange-Mount is ideal for this application.

1 Flange-mounted connection

Flange-mounted connection is obtained by means of a copper-nickel flange affixed to the DuraCooler® header coupled to a mild ASTM steel mating flange, supplied with the cooler.

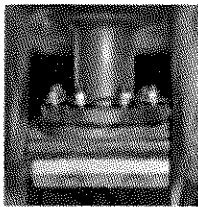

2 Streamlined header design

Significantly increases heat transfer efficiency over square-head design.

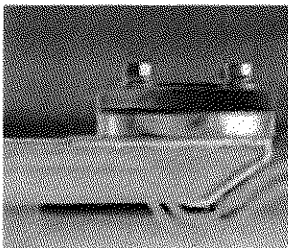

3 Two-piece header design

Allows for brazing on inside and outside of the header which, in turn, increases the integrity and reduces the chance of leakage.

Heavy-gauge material for headers

▸ Provides exceptional strength and durability.

Premium-grade silver solder

▸ Provides maximum strength, flexibility and leak resistance at all cooler joints.

▸ Every DuraCooler® is pressure and vibration tested to verify joint integrity.

4 Patented flow port

Exclusive, patented design of internal coolant flow port increases cooling performance of outside tubes.

5 Anodes mounted on beveled edge of header

Results in less stand-off distance from hull, less drag, better fuel efficiency. Also, they are less likely to be damaged by debris.

6 Rigid one-piece construction

Allows for easier installation and removal.

7 90/10 Copper-Nickel tubing

▸ High-strength material has excellent anti-fouling and heat transfer properties.

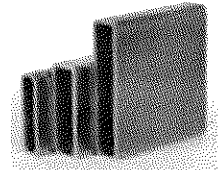

It also resists water-flow erosion.

▸ All tubes come in wall thickness of 0.062 inches.

Tubes come in three different sizes:

▸ #2 Tubes: 0.343" wide x 1.500" high.

▸ #3 Tubes: 0.500" wide x 1.687" high.

▸ #4 Tubes: 0.500" wide x 2.500" high.

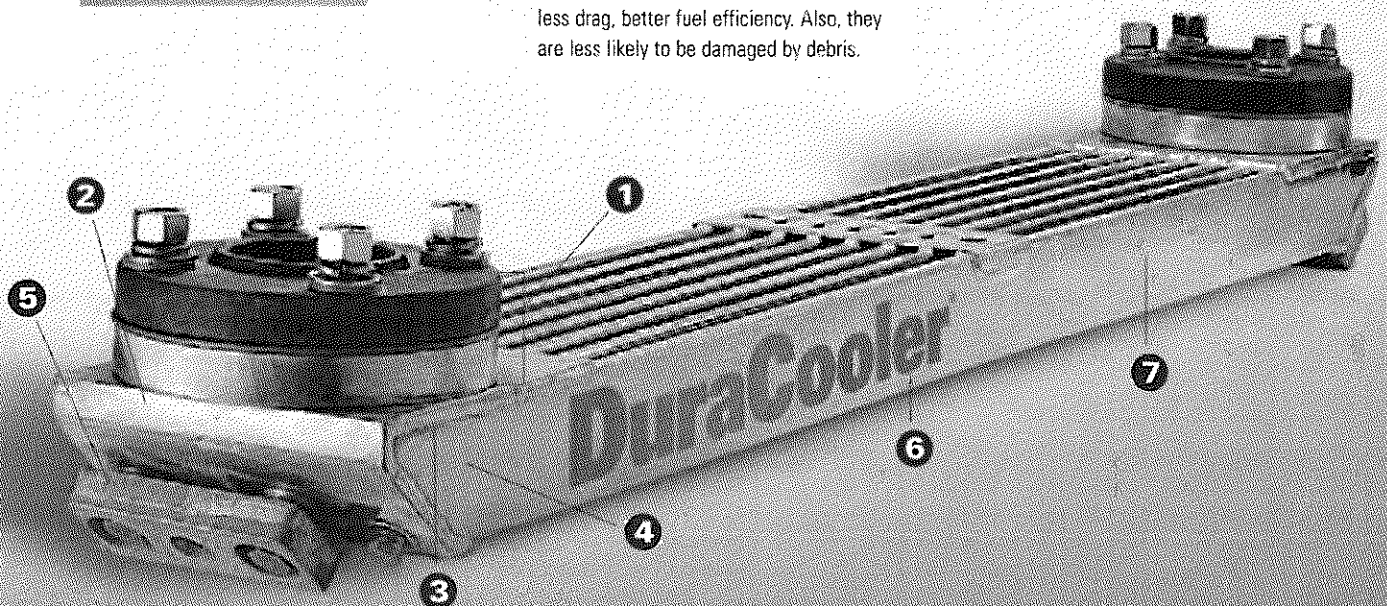

Mounting configurations and internal plumbing, engineered and built to fit your exact needs.

The DuraCooler® is custom-sized and manufactured to meet your engine specifications, along with space and operational requirements. The cooler can be engineered to cool main and auxiliary diesels, as well as other heat sources that include: generators, winches, compressors, thrusters, air conditioning units, and gears. It is also available to match your specific internal plumbing configurations.

Plumbing options

Single Pass Design.

Designed to accommodate internal plumbing with nozzles on the opposite ends of the cooler, for quick and easy installation. Nozzles are available in various lengths and diameters.

Double Pass Design.

Designed to accommodate internal plumbing that requires nozzles on same end of the cooler. This configuration allows the internal plumbing to be more centrally located. Nozzles are available in various lengths and diameters.

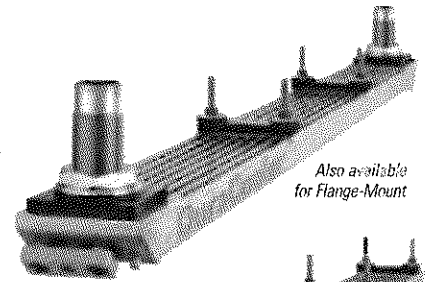

Also available for Flange-Mount

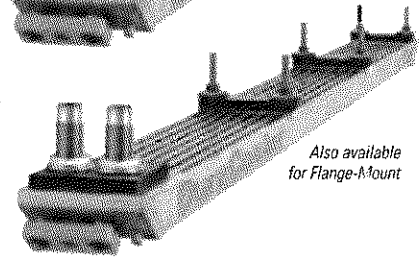

Also available for Flange-Mount

Mounting options: Through-hull

Our standard through-hull system's sturdy one-piece construction makes it quick and easy to install. The standard Through-Hull DuraCooler® is manufactured with robust copper-nickel nozzles and the DuraCooler® assembly system is designed to isolate the cooler from the hull, minimizing the effects of galvanic corrosion.

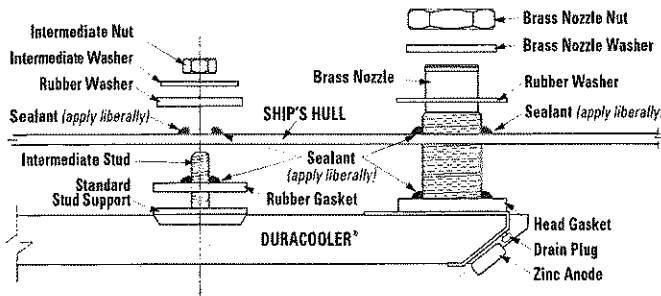

H-Series bracket mounting for through-hull (optional).

DuraCoolers are typically manufactured with through-hull mounting studs (as shown above). The optional H-bracket mounting system eliminates the need for through-hull penetration and the fabrication of cofferdams. The H-bracket extends beyond the sides of the cooler and is permanently affixed to the cooler using silver solder. Studs are welded to the hull and the cooler is attached with fasteners to the H-bracket.

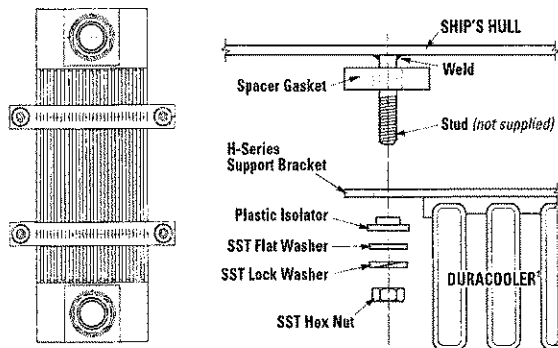

Mounting options: Flange-mount

For flange-mount configurations, a schedule 80 pipe is welded to the steel pipe flange supplied with the DuraCooler® unit. The DuraCooler® flange is bolted to the steel flange, using the supplied hardware. The pipe is extended through the hull and is welded to the hull on both sides. Mounting gaskets and plastic isolating washers isolate the cooler from the hull to minimize galvanic corrosion.

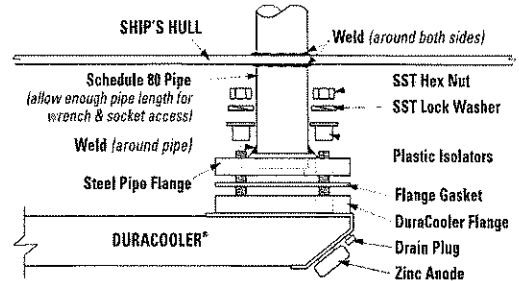

H-Series bracket mounting for flange-mount (standard).

All Flange-mount DuraCoolers come standard with the H-bracket mounting system. The H-bracket is made from heavy gauge copper-nickel and is permanently attached to the DuraCooler®. To mount the flanged DuraCooler® using the H-bracket, "L" shaped support angles are welded to the hull. The Flange-Mount DuraCooler® can then be secured to these small angled pieces, eliminating through-hull penetration.

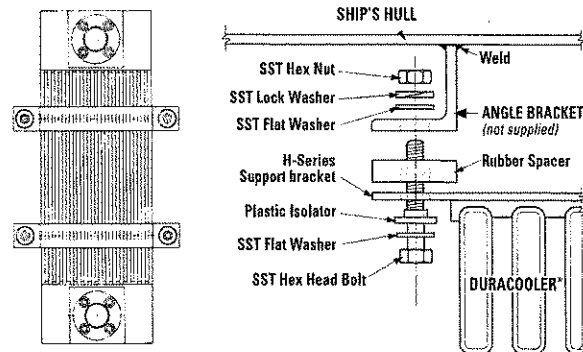

Installation location is flexible depending on the vessel's hull design and operating conditions.

Side-mounting.

On shallow-draft vessels, the DuraCooler® can be mounted on the side of the hull or beside the skeg to take advantage of additional water current created by the propeller. Side mounting also protects the cooler if you run aground.

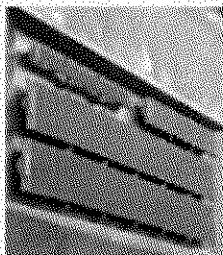

Mounting near propeller.

Mounting the DuraCooler® near the propeller takes advantage of the slipstream created by the propeller during heavy towing situations.



Recessing the DuraCooler®

Recessing the DuraCooler® reduces the drag on the vessel, streamlines the installation and protects the cooler from damage. On fast moving or planing hull vessels, the DuraCooler® is normally recessed-mounted alongside the keel.

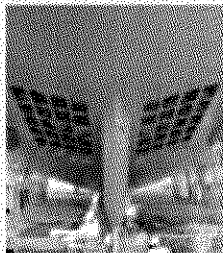

Protecting with fairing blocks.

When externally mounting the cooler, fairing blocks and side plates are used for protection from damage. Our engineers can offer assistance in the proper engineering and placement of protective fairing blocks around the DuraCooler®.

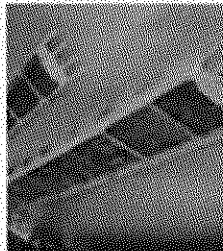

DuraCooler® can be bent to accommodate hull curvature.

If there is a circumstance where the mounting area on your hull is not flat or cannot be made flat, it is possible to bend or twist the DuraCooler®. We can provide this service for you, or our engineers can instruct you on how you can do it yourself. Contact Duramax Marine® for more information.

Cofferdam classification requirements.

For a Through-Hull DuraCooler®, a seachest or cofferdam is required by A.B.S. It should be constructed to meet A.B.S., Coast Guard or other agency regulations. Alternatively, the Flange-Mount DuraCooler® has no through-hull penetrations and therefore does not require the use of a cofferdam or seachest.

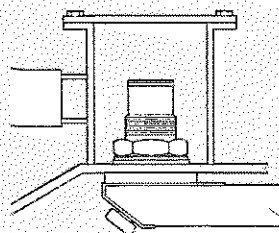

The DuraCooler® is custom-sized for your vessel.

To correctly size a DuraCooler® for your specific application, we consider your vessel's external operating conditions, main engine information, generator and other factors used to determine your engine specifications and operational requirements.

The following information is required to correctly engineer and size your DuraCooler® Heat Exchange System:

▶ VESSEL OPERATING CONDITIONS

Minimum Vessel Speed at Full Power _____ (knots/mph)
 Maximum Ambient Sea Water Temperature _____ (C°/F°)
 Maximum Hull Speed _____ (knots/mph)
 Glycol in Coolant _____ (%)

▶ HULL CONSTRUCTION

Steel Fiberglass Wood Aluminum

▶ MAIN ENGINE

Manufacturer _____
 Model No. and Year _____
 HP@RPM of Engine _____

▶ GEARS (Cooled by a DuraCooler®)

Twin Disc/ZF® Reintjes®
 Other _____
 Model No. and Year _____
 Reintjes® Gear (provide water pump flow GPM) _____
 System Pressure Drop Requirements _____

▶ CIRCUITS COOLED

Jacket Water After Cooler Combined Circuit

▶ FOR LOW TEMP CIRCUITS (After Cooler, Combined, LTA)

Specify low temp to cooler _____
 OR Specify low temp from cooler _____

▶ GENERATOR

Manufacturer _____
 Model No. and Year _____
 KW@RPM of Engine _____

▶ OTHER HEAT SOURCES (Pump, Thruster, Etc.)

Manufacturer _____
 Model No. and Year _____

▶ DURACOOLER® DESIGN PREFERRED (check one)

Through-Hull Flange-Mount
 Preferred Inlet/Outlet Location: (check one)
 Same End (double pass) Opposite Ends (single pass)

▶ SPACE AVAILABLE (on hull)

Maximum Length _____ Maximum Width _____

For More Information or a Quotation, contact your Duramax Marine® DuraCooler® Expert. Call 440-834-5400. Or visit DuramaxMarine.com.

INNOVATION.
EXPERIENCE.
RESULTS.

Duramax Marine® is committed to providing excellence in every product we manufacture. Our Johnson Cutless® marine and industrial bearings, heat exchangers, impact protection systems and sealing systems are known worldwide for their engineered quality and dependable performance. Please contact the factory for information on any of the following Duramax Marine® products:



JOHNSON CUTLESS® WATER-LUBRICATED BEARING SYSTEMS

Johnson Cutless® Sleeve and Flanged Bearings
DX 490 Rudder Bushings



DURAMAX® ADVANCED WATER-LUBRICATED BEARING SYSTEMS

Johnson® Demountable Stave Bearings
ROMOR® I Stave Bearings and Segmental Housings
ROMOR® C- Partial Arc Bearings
DMX® Polymer Alloy Bearings
Industrial Pump Bearing Systems



DURAMAX® HEAT EXCHANGE SYSTEMS

DuraCooler® Keel Coolers
Duramax® Demountable Keel Coolers
Duramax® BoxCoolers



DURAMAX® IMPACT PROTECTION SYSTEMS

Johnson® Commercial Dock Bumpers, Fenders & Tow Knees
Weatherstrip Door Gaskets, Window Channel and Hatch Cover Gaskets
LINERITE® Composite Batterboard Systems



DURAMAX® SHAFT SEALING SYSTEMS

Duramax® Shaft Seal Systems
Johnson® Heavy-Duty Air Seal Stuffing Boxes
Duramax® Ultra-X® High Performance Compression Packing
Johnson® Strong Boy Stern Castings and Stuffing Boxes

© 2007 Duramax Marine®
17590 Great Lakes Parkway
Hiram, Ohio 44234 U.S.A.
PHONE 440.834.5400
FAX 800.497.9283 USA & Canada
or 440.834.4950
info@DuramaxMarine.com
www.DuramaxMarine.com

DURAMAX MARINE

