

**CONSTRUCTION NOTES**

1. ALL WORK SHALL CONFORM TO THE APPLICABLE CODES AND ORDINANCES.
2. CONTRACTOR SHALL VISIT THE SITE AND FAMILIARIZE HIM OR HERSELF WITH ALL CONDITIONS AFFECTING THE PROPOSED WORK AND SHALL MAKE PROVISION AS TO THE COST THEREOF. CONTRACTOR SHALL BE RESPONSIBLE FOR FAMILIARIZING HIM OR HERSELF WITH ALL CONTRACT DOCUMENTS, FIELD CONDITIONS AND DIMENSIONS AND CONFIRMING THAT THE WORK MAY BE ACCOMPLISHED AS SHOWN PRIOR TO PROCEEDING WITH CONSTRUCTION. ANY DISCREPANCIES SHALL BE BROUGHT TO THE ATTENTION OF THE ENGINEER PRIOR TO THE COMMENCEMENT OF WORK.
3. CONTRACTOR SHALL NOTIFY ENGINEER OF ALL PRODUCTS OR ITEMS NOTED AS "EXISTING" WHICH ARE NOT FOUND IN THE FIELD.
4. INSTALL ALL EQUIPMENT AND MATERIALS IN ACCORDANCE WITH MANUFACTURER'S RECOMMENDATIONS AND OWNER'S REQUIREMENTS UNLESS SPECIFICALLY OTHERWISE INDICATED OR WHERE LOCAL CODES OR REGULATIONS TAKE PRECEDENCE.
5. CONTRACTOR SHALL VERIFY ALL DIMENSIONS AND CONDITIONS IN THE FIELD PRIOR TO FABRICATION AND ERECTION OF ANY MATERIAL. ANY UNUSUAL CONDITIONS SHALL BE REPORTED TO THE ATTENTION OF THE ENGINEER.
6. CONTRACTOR SHALL CLEAN AND REMOVE DEBRIS AND SEDIMENT DEPOSITED ON PUBLIC STREETS, SIDEWALKS, ADJACENT AREAS, OR OTHER PUBLIC WAYS DUE TO CONSTRUCTION.
7. CONTRACTOR SHALL INCORPORATE PROVISIONS AS NECESSARY IN CONSTRUCTION TO PROTECT EXISTING STRUCTURES, PHYSICAL FEATURES, AND MAINTAIN SITE STABILITY DURING CONSTRUCTION. CONTRACTOR SHALL RESTORE ALL AREAS TO ORIGINAL CONDITION AND AS DIRECTED BY DESIGN DRAWINGS.
8. SITE CONTRACTOR SHALL OBTAIN ALL REQUIRED PERMITS PRIOR TO CONSTRUCTION.
9. ALL EROSION AND SEDIMENT CONTROL MEASURES SHALL BE INSTALLED IN ACCORDANCE WITH "MAINE EROSION AND SEDIMENTATION CONTROL HANDBOOK FOR CONSTRUCTION, BEST MANAGEMENT PRACTICES" PUBLISHED BY THE CONSUMER AND COLLECTOR DISTRICT AND MAINE DEPARTMENT OF ENVIRONMENTAL PROTECTION, MARCH 1991 OR LATEST EDITION. IT SHALL BE THE RESPONSIBILITY OF THE CONTRACTOR TO POSSESS A COPY OF THE EROSION CONTROL PLAN AT ALL TIMES.
10. THE CONTRACTOR IS HEREBY CAUTIONED THAT ALL SITE FEATURES SHOWN HEREON ARE BASED ON FIELD OBSERVATIONS BY THE SURVEYOR AND BY INFORMATION PROVIDED BY UTILITY COMPANIES. THE INFORMATION IS NOT TO BE RELIED ON AS BEING EXACT OR COMPLETE. THE CONTRACTOR SHALL CONTACT DIG SAFE (811) AT LEAST THREE (3) BUT NOT MORE THAN THIRTY (30) DAYS PRIOR TO COMMENCEMENT OF EXCAVATION OR DEMOLITION TO VERIFY HORIZONTAL AND VERTICAL LOCATION OF ALL UTILITIES.
11. CONTRACTOR SHALL BE AWARE THAT DIG SAFE ONLY NOTIFIES ITS "MEMBER" UTILITIES ABOUT THE DIG. WHEN NOTIFIED, DIG SAFE WILL ADVISE CONTRACTOR OF MEMBER UTILITIES IN THE AREA. CONTRACTOR IS RESPONSIBLE FOR IDENTIFYING AND CONTACTING NON-MEMBER UTILITIES DIRECTLY. NON-MEMBER UTILITIES MAY INCLUDE TOWN OR CITY WATER AND SEWER DISTRICTS AND SMALL LOCAL UTILITIES, AS WELL AS USG PUBLIC WORKS SYSTEMS.
12. CONTRACTOR SHALL BE RESPONSIBLE FOR COMPLIANCE WITH THE REQUIREMENTS OF 23 MRS 3360-A. IT SHALL BE THE RESPONSIBILITY OF THE CONTRACTOR TO COORDINATE WITH THE APPROPRIATE UTILITIES TO OBTAIN AUTHORIZATION PRIOR TO RELOCATION OF ANY EXISTING UTILITIES WHICH CONFLICT WITH THE PROPOSED IMPROVEMENTS SHOWN ON THESE PLANS. IF A UTILITY CONFLICT ARISES, THE CONTRACTOR SHALL IMMEDIATELY NOTIFY THE OWNER, THE MUNICIPALITY AND APPROPRIATE UTILITY COMPANY PRIOR TO PROCEEDING WITH ANY RELOCATION.
13. ALL PAVEMENT MARKINGS AND DIRECTIONAL SIGNAGE SHOWN ON THE PLAN SHALL CONFORM TO THE MANUAL OF UNIFORM TRAFFIC CONTROL DEVICES (MUTCD) STANDARDS.
14. ALL PAVEMENT JOINTS SHALL BE SAUCUT PRIOR TO PAVING TO PROVIDE A DURABLE AND UNIFORM JOINT.
15. NO HOLES, TRENCHES OR STRUCTURES SHALL BE LEFT OPEN OVERNIGHT IN ANY EXCAVATION ACCESSIBLE TO THE PUBLIC OR IN PUBLIC RIGHT-OF-WAY.
16. ALL WORK WITHIN THE PUBLIC RIGHT-OF-WAY SHALL REQUIRE PERMIT FROM THE TOWN OF NAPLES.
17. IMMEDIATELY UPON COMPLETION OF CUTS/FILLS, THE CONTRACTOR SHALL STABILIZE DISTURBED AREAS IN ACCORDANCE WITH EROSION CONTROL NOTES AND AS SPECIFIED ON PLANS.
18. THE CONTRACTOR SHALL BE FULLY AND SOLELY RESPONSIBLE FOR THE REMOVAL, REPLACEMENT AND RECTIFICATION OF ALL DAMAGED AND DEFECTIVE MATERIAL AND WORKMANSHIP IN CONNECTION WITH THE CONTRACT WORK. THE CONTRACTOR SHALL REPLACE OR REPAIR AS DIRECTED BY THE OWNER ALL SUCH DAMAGED OR DEFECTIVE MATERIALS WHICH APPEAR WITHIN A PERIOD OF ONE YEAR FROM THE DATE OF SUBSTANTIAL COMPLETION.
19. ALL WORK PERFORMED BY THE GENERAL CONTRACTOR AND/OR TRADE SUBCONTRACTOR SHALL CONFORM TO THE REQUIREMENTS OF LOCAL, STATE OR FEDERAL LAWS, AS WELL AS ANY OTHER GOVERNING REQUIREMENTS, WHETHER OR NOT SPECIFIED ON THE DRAWINGS.
20. WHERE THE TERMS "APPROVED EQUAL", "OTHER APPROVED", "EQUAL TO", "ACCEPTABLE" OR OTHER GENERAL QUALIFYING TERMS ARE USED IN THESE NOTES, IT SHALL BE UNDERSTOOD THAT REFERENCE IS MADE TO THE RULING AND JUDGMENT OF SEBAGO TECHNICS, INC.
21. THE GENERAL CONTRACTOR SHALL PROVIDE ALL NECESSARY PROTECTION FOR THE WORK UNTIL TURNED OVER TO THE OWNER.
22. THE GENERAL CONTRACTOR SHALL MAINTAIN A CURRENT AND COMPLETE SET OF CONSTRUCTION DRAWINGS ON SITE DURING ALL PHASES OF CONSTRUCTION FOR USE OF ALL TRADES.
23. THE CONTRACTOR SHALL TAKE FULL RESPONSIBILITY FOR ANY CHANGES AND DEVIATION OF APPROVED PLANS NOT AUTHORIZED BY THE ARCHITECT/ENGINEER AND/OR CLIENT/OWNER.
24. DETAILS ARE INTENDED TO SHOW END RESULT OF DESIGN. ANY MODIFICATION TO SUIT FIELD DIMENSION AND CONDITION SHALL BE SUBMITTED TO THE ENGINEER FOR REVIEW AND APPROVAL PRIOR TO ANY WORK.
25. BEFORE THE FINAL ACCEPTANCE OF THE PROJECT, THE CONTRACTOR SHALL REMOVE ALL EQUIPMENT AND MATERIALS, REPAIR OR REPLACE PRIVATE OR PUBLIC PROPERTY WHICH MAY HAVE BEEN DAMAGED OR DESTROYED DURING CONSTRUCTION, CLEAN THE AREAS WITHIN AND ADJACENT TO THE PROJECT WHICH HAVE BEEN OBSTRUCTED BY HIS/HER OPERATIONS, AND LEAVE THE PROJECT AREA NEAT AND PRESENTABLE.
26. ALL SUBSURFACE UTILITY LINES SHOWN HEREON ARE BASED SOLELY ON THE FIELD LOCATION OF VISIBLE STRUCTURES, SMH'S, CB'S, HYDRANTS, ETC. IN CONJUNCTION WITH DESIGN AND OR AS-BUILT PLANS SUPPLIED TO SEBAGO TECHNICS, INC. BY OTHERS. PRIOR TO ANY CONSTRUCTION, EXCAVATION, TEST BORINGS, DRILLINGS, ETC. DIG SAFE MUST BE NOTIFIED AND A SITE IDENTIFICATION NUMBER ALONG WITH A SAFE TO DIG DATE OBTAINED. THE SITE CONTRACTOR SHALL BE RESPONSIBLE FOR FIELD VERIFYING THE LOCATION, DEPTH AND MATERIAL OF ALL SUBSURFACE UTILITY LINES SHOWN HEREON AND ANY AND ALL OTHERS LOCATED ON SITE WITHIN THE CONSTRUCTION AREA.

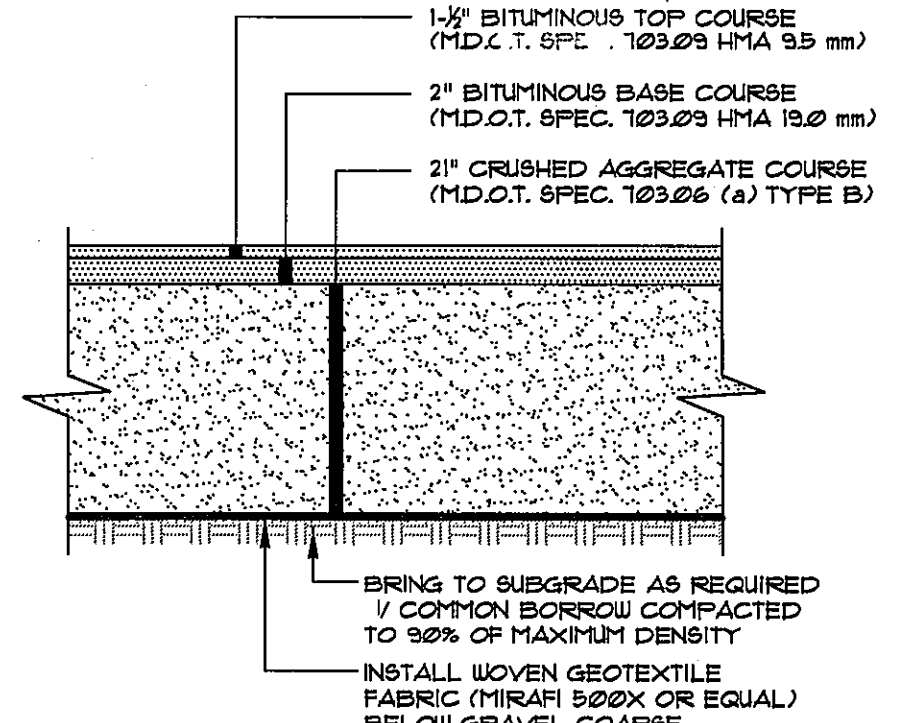

- NOTES:**
1. COMPACT GRAVEL COURSE TO 98% OF MAXIMUM DENSITY USING HEAVY ROLLER COMPACTION.
  2. CONTRACTOR SHALL SET GRADE STAKES MARKING SUBBASE AND FINISH GRADE ELEVATIONS FOR CONSTRUCTION REFERENCE.

**TYP. PAVED SECTION**  
NOT TO SCALE

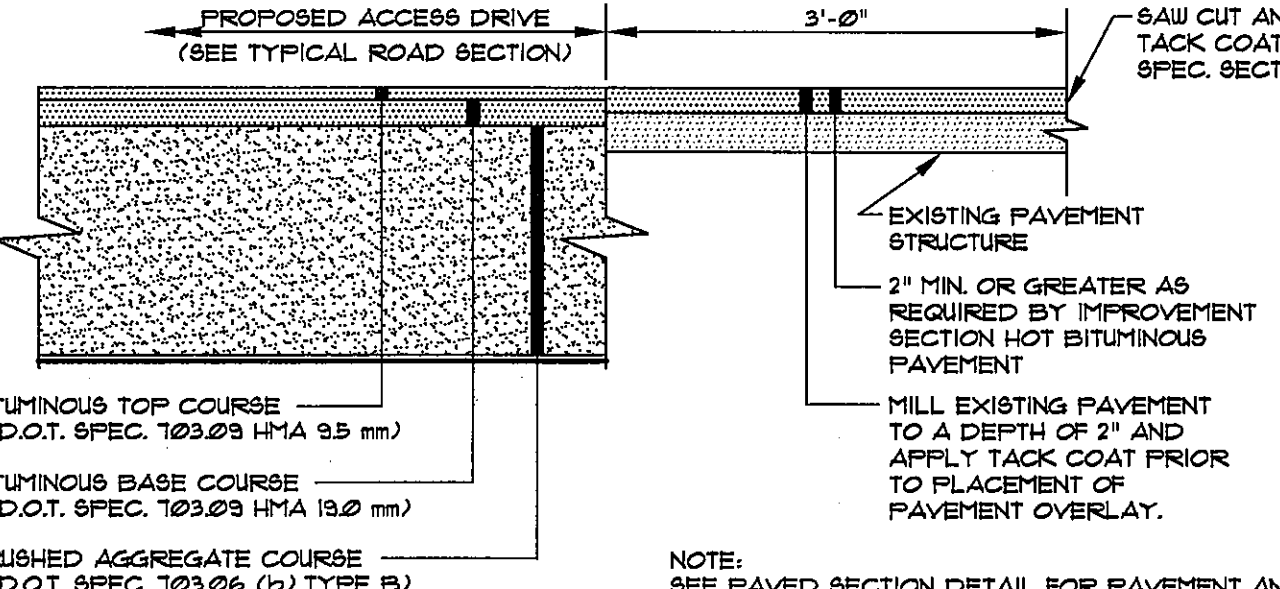

**TYPICAL PAVEMENT JOINT**  
NOT TO SCALE

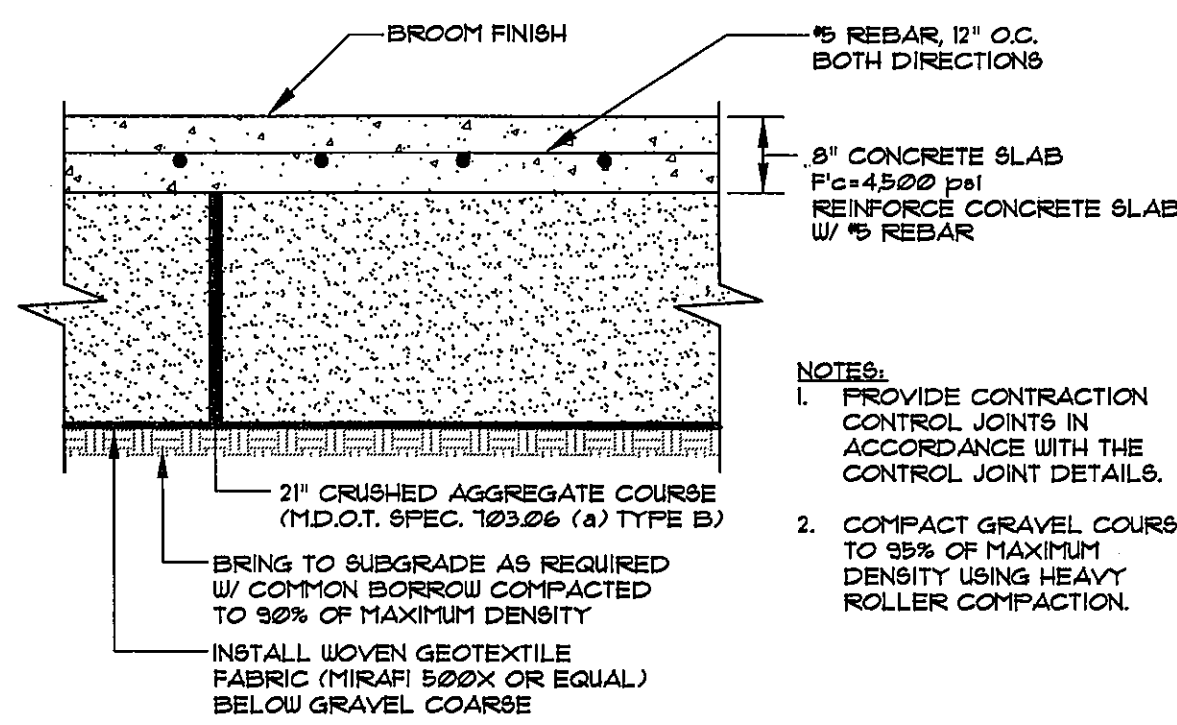

**TYPICAL CONCRETE SLAB**  
NOT TO SCALE

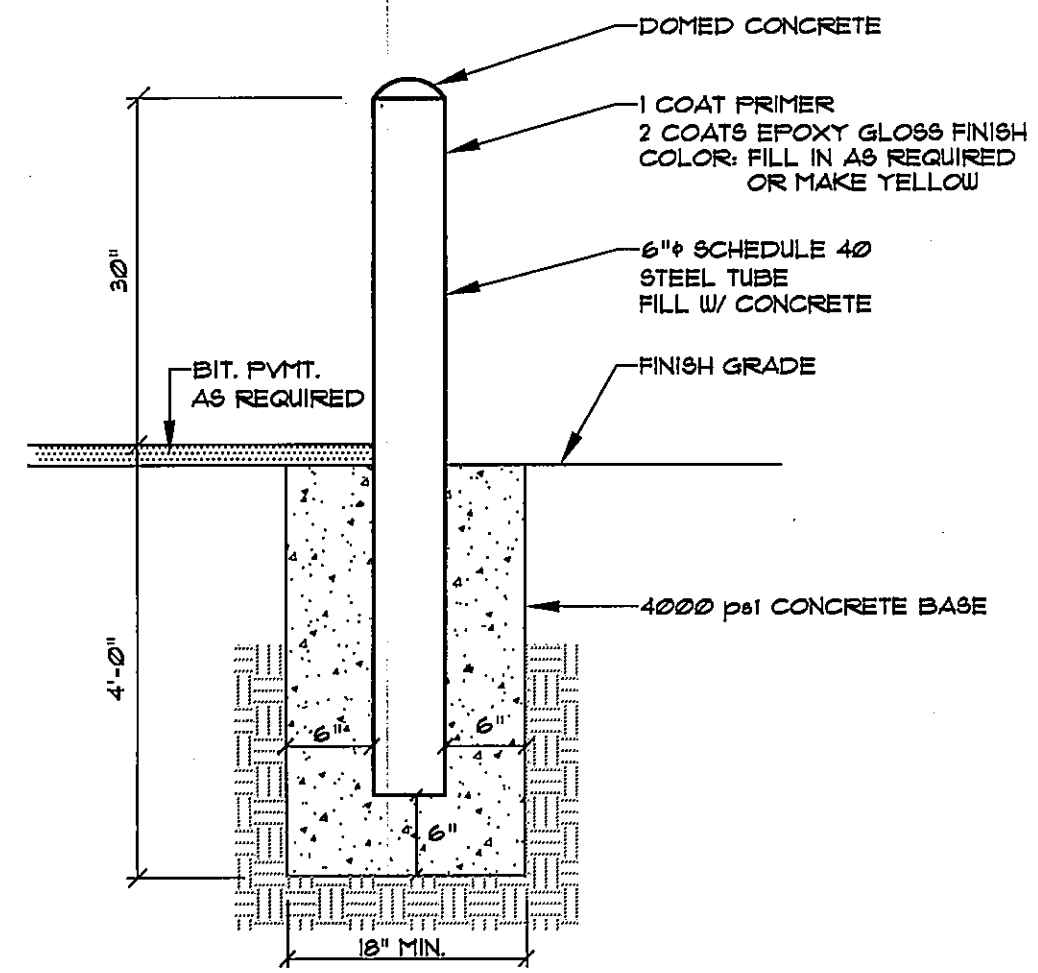

**METAL BOLLARD**  
NOT TO SCALE

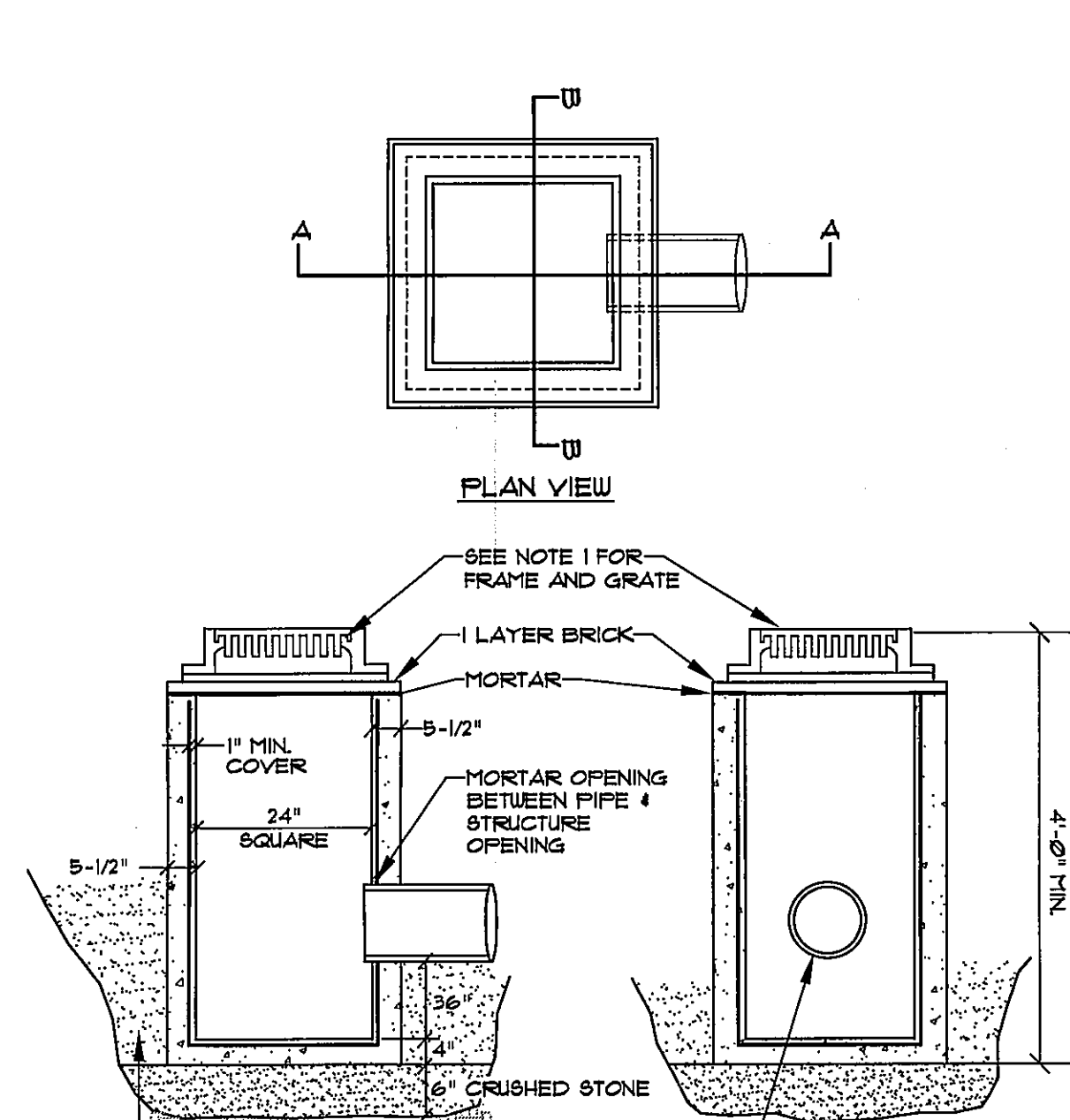

**TYP. TYPE "F" CATCH BASIN**  
NOT TO SCALE

- NOTES:**
1. FRAME SHALL BE FOR 24" SQUARE GRATE - LEBARON TYPE 1" SQUARE FRAME (LF 345) 4" FLANGE OR ETHERIDGE SQUARE FRAME 824G. GRATE SHALL BE 24"x24" CAST IRON.
  2. ENTIRE CATCH BASIN WITH EXCEPTION OF LEVELING BRICK FRAME AND GRATE TO BE PRECAST AS SINGLE PORTLAND CEMENT CONCRETE UNIT.

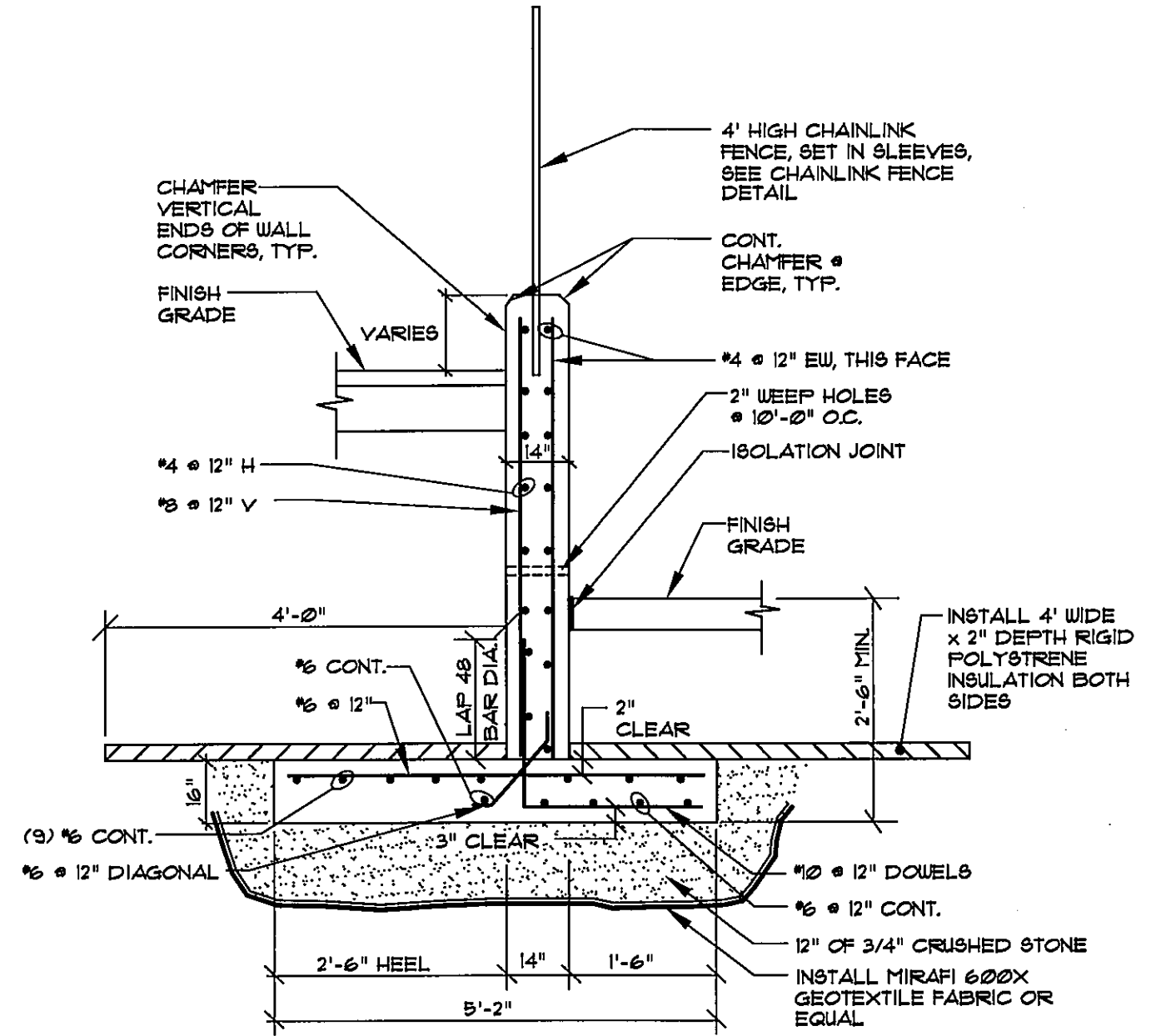

**TYP. RETAINING WALL REINFORCING DETAIL**  
NOT TO SCALE

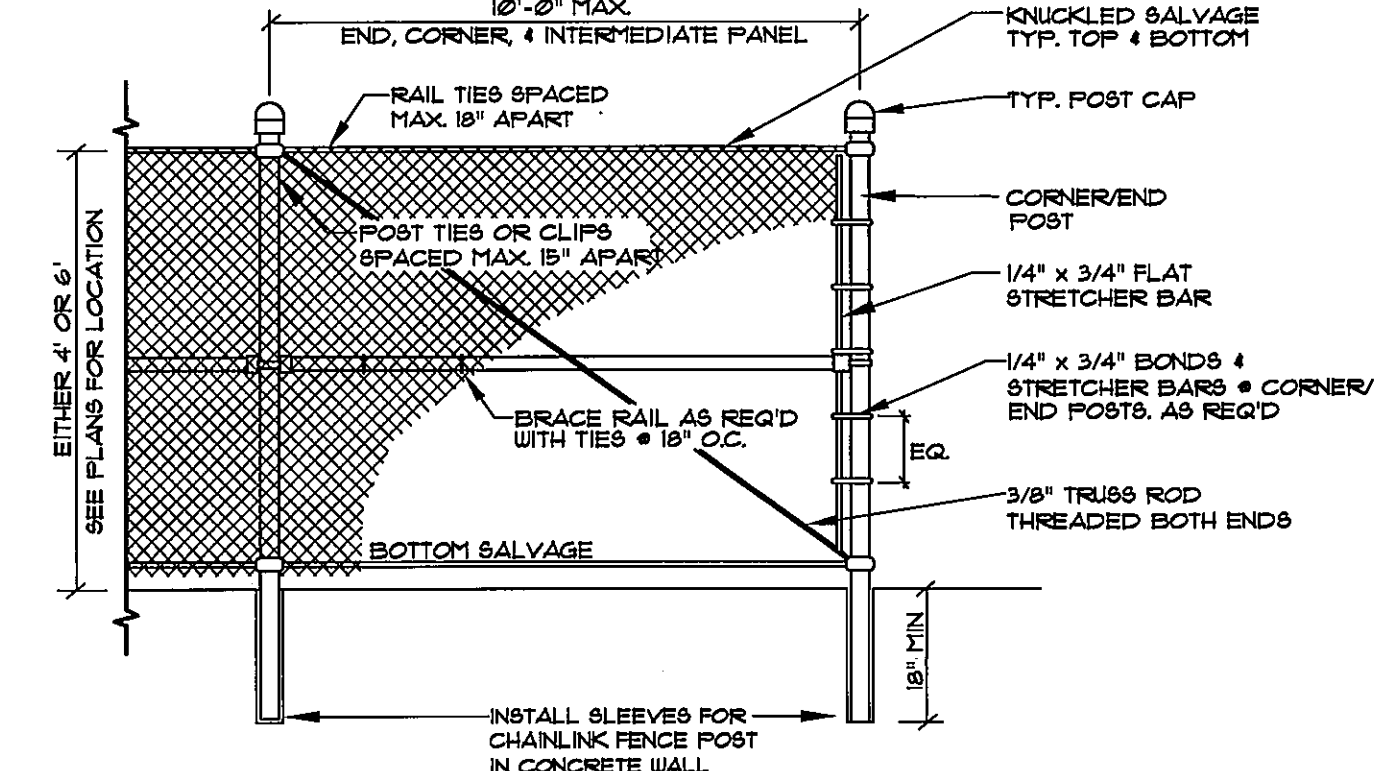

**TYPICAL CHAIN LINK FENCE**  
NOT TO SCALE

- NOTES:**
1. CORNER OR END POST: NOMINAL 3" O.D. GALVANIZED STEEL PIPE, MIN. 5.19 LB/LF.
  2. INTERMEDIATE POST: NOMINAL 2-1/2" O.D. GALVANIZED STEEL PIPE, MIN. 3.65 LB/LF.
  3. BRACES (TOP & BOTTOM): NOMINAL 1-5/8" O.D. GALVANIZED STEEL PIPE, MIN. 2.21 LB/LF.
  4. THE OUTSIDE OF THE FENCE FABRIC SHALL BE 3" INSIDE THE EDGE OF PAVEMENT.
  5. BRACE RAIL AND DIAGONAL BRACE ROD SHALL BE INSTALLED AT EACH 10' CORNER SECTION OF ENCLOSURE.
  6. CONCRETE SHALL HAVE MINIMUM COMPRESSIVE STRENGTH (f'c) OF 3000 PSI WITH 6% AIR ENTRAINMENT.
  7. SUBMIT SHOP DRAWINGS FOR OWNER'S/ENGINEER'S APPROVAL.
  8. FENCE FABRIC, POSTS, RAILS AND AFFURTEANCES SHALL BE VINYL CLAD; COLOR: BLACK.

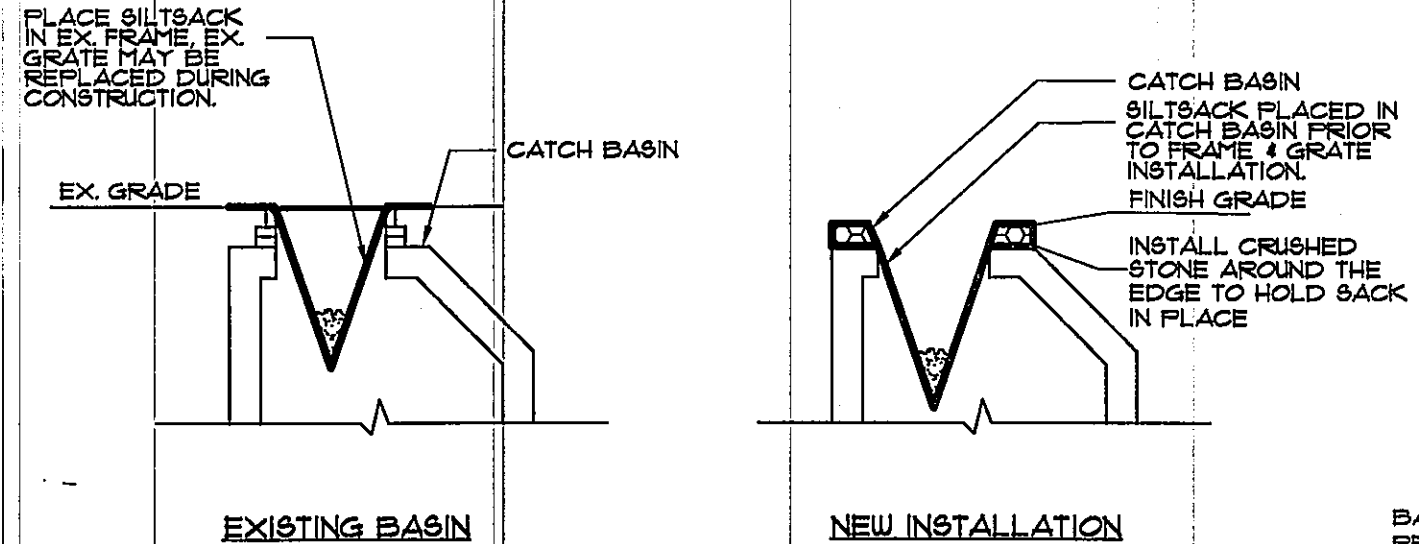

**CATCH BASIN PROTECTION DETAIL (FOR PAVED AREAS)**  
NOT TO SCALE

- NOTES:**
- PRIOR TO FINAL GRADING AND PAVING OPERATIONS BEGIN A CATCH BASIN INSERT (SUCH AS A SILT SACK OR A DANDY BAG) MUST BE INSTALLED IN EXISTING BASIN PER MANUFACTURER'S INSTRUCTIONS. HAY BALES SHOULD BE REMOVED ONCE INSERTS ARE INSTALLED.

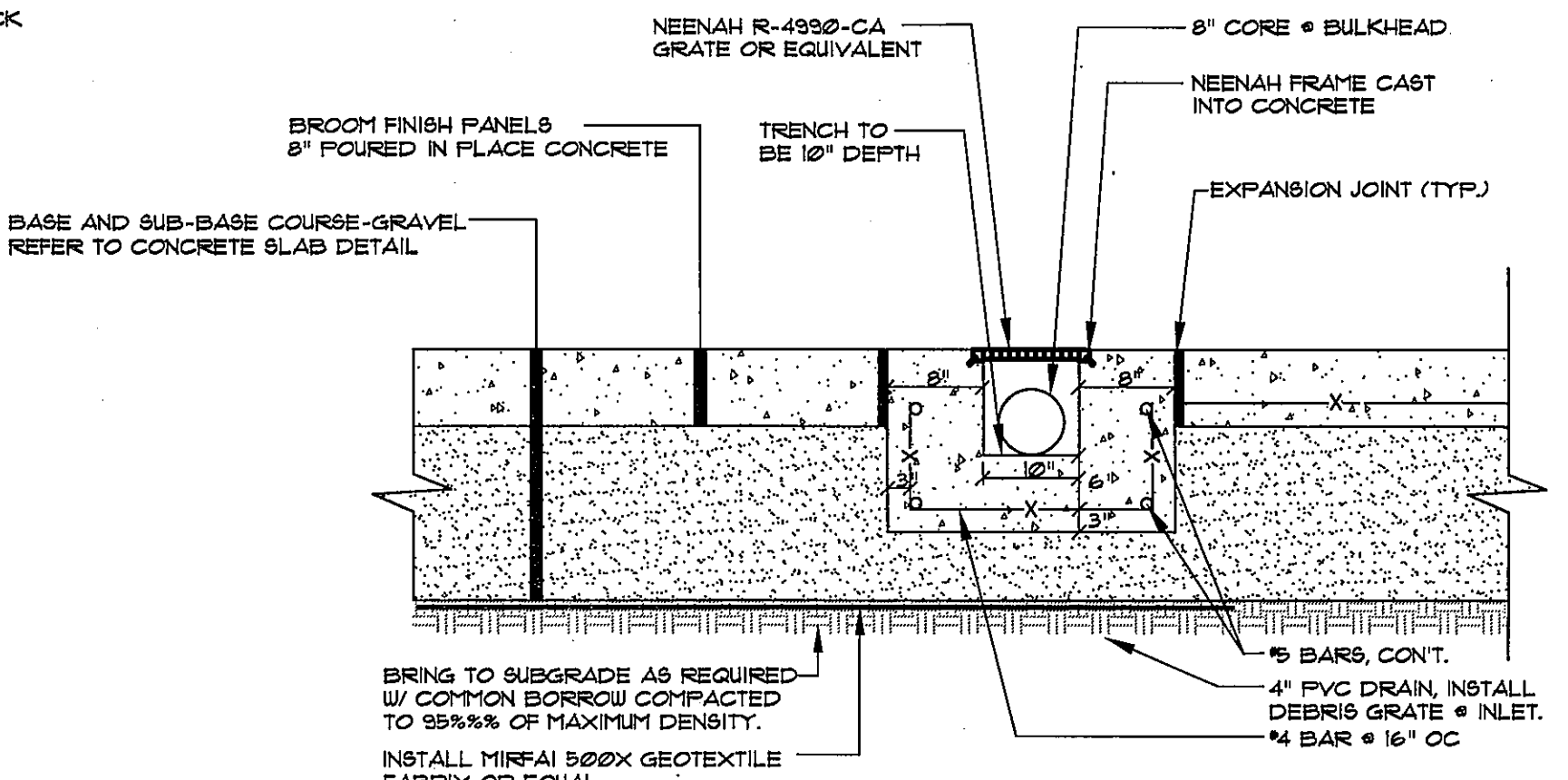

**TRENCH DRAIN CROSS SECTION**  
NOT TO SCALE

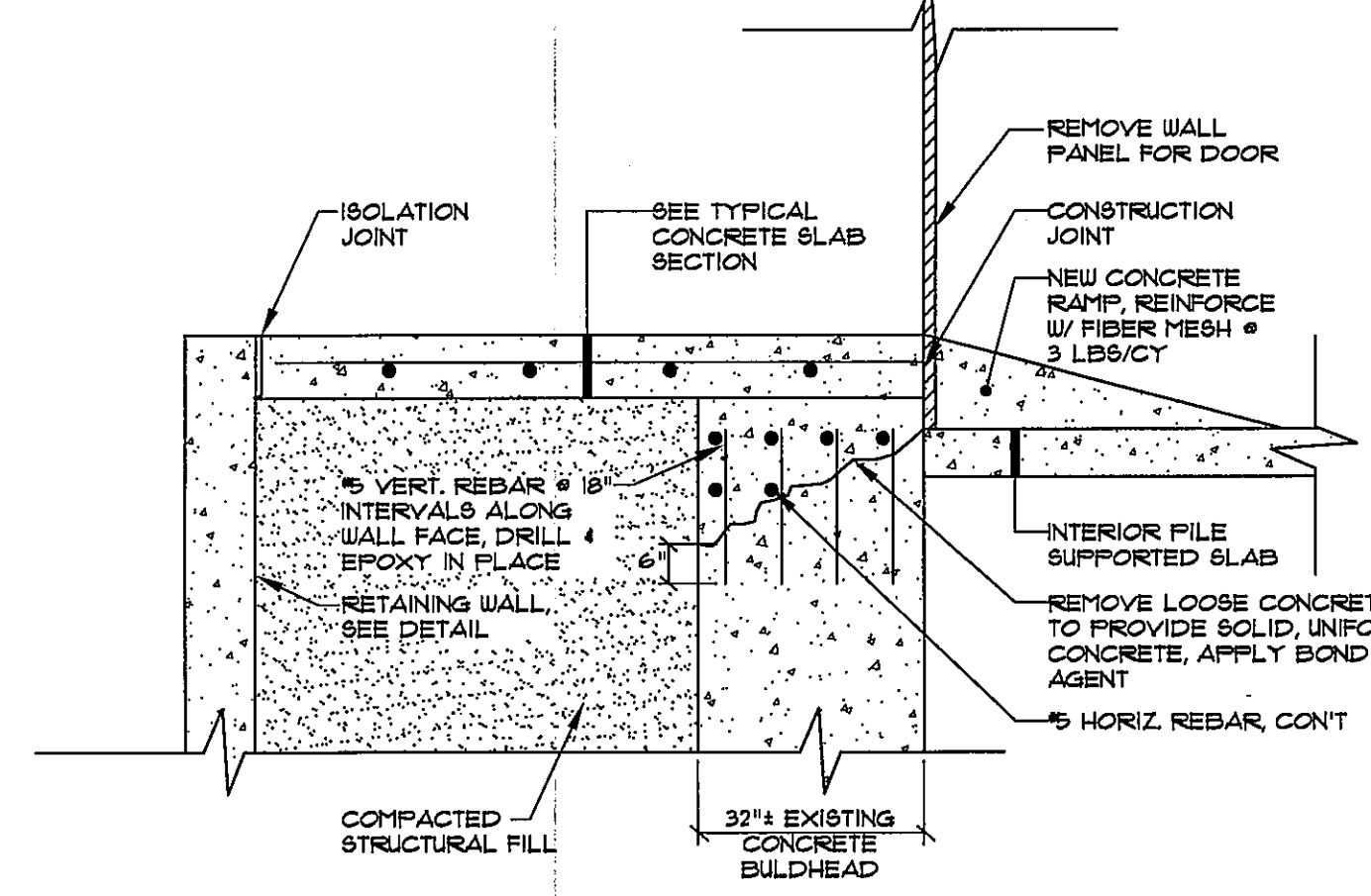

**LOADING DOCK WALL IMPROVEMENT**  
NOT TO SCALE

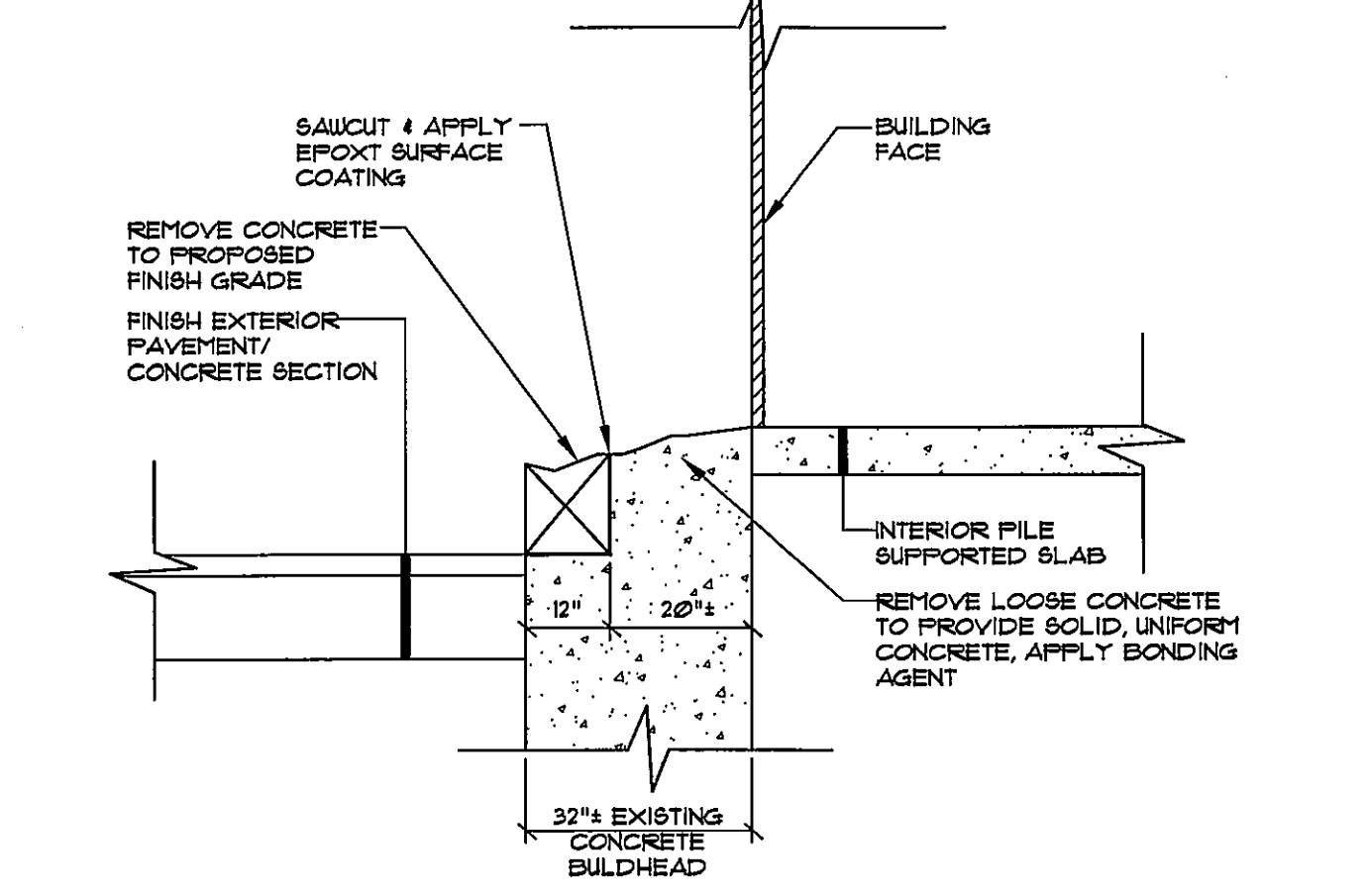

**LONGITUDINAL WALL SAW CUT**  
NOT TO SCALE

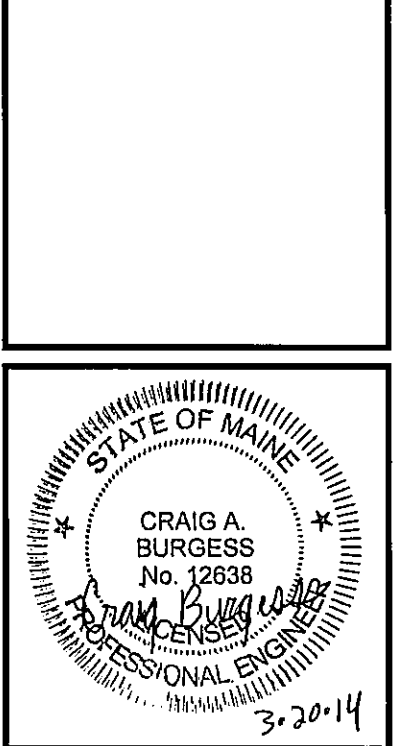

PROJECT NO.	13430
FIELD BOOK	
DESIGN	CHMD
DRAWN	CAB
DATE	03-20-14
STATUS	APPROVAL
BY	A OAM
REV.	

**SEBAGO TECHNICS**  
WWW.SEBAGOTECHNICS.COM  
76 John Roberts Rd., Suite 1A  
South Portland, ME 04106  
(603) 270-2800 FAX (603) 270-2808

**SITE DETAILS & NOTES**  
OF: MAINE STATE PIER PROCESSING FACILITY  
COMMERCIAL STREET  
PORTLAND, MAINE 04101  
FOR: SHUCKS MAINE LOBSTER  
150 MAIN STREET  
RICHMOND, ME 04357