

POWER-fin[®]

Installation & Operation Manual

Models: 502, 752, 1002, 1302,
1501, 1701, and 2001
Up To 5:1 Turndown



Lochinvar[®]
High Efficiency Water Heaters, Boilers and Pool Heaters

⚠ WARNING:

This manual supplies information for the installation, operation, and servicing of the appliance. It is strongly recommended that this manual and the Power-fin Service Manual be reviewed completely before proceeding with an installation. Perform steps in the order given. Failure to comply could result in severe personal injury, death, or substantial property damage.

Save this manual for future reference.

Contents

Hazard definitions	2
Please read before proceeding	3
Ratings	5
The Power-fin -- How it works	6
1. Determine unit location	9
2. Venting - Before You Begin	13
Condensing vent options: CAT II & IV	15
Non-Condensing vent options: CAT I	19
Common venting CAT I & II	21
CAT I, II, & IV general venting information	22
CAT IV specific venting information	22
CAT II & IV drain tee requirements	23
CAT I specific venting information	23
Vertical air inlet	24
Horizontal air inlet	25
Vertical vent termination clearances	27
Sidewall vent termination clearances	29
3. Gas connections	31
4. Water connections	35
5. Electrical connections	44
6. Condensate disposal	49
7. Start-up	50
8. Operating information	56
9. Domestic water heaters	68
10. Wiring diagram	77
11. Ladder diagram	78
Revision Notes	Back Cover

Hazard definitions

The following defined terms are used throughout this manual to bring attention to the presence of hazards of various risk levels or to important information concerning the life of the product.

⚠ DANGER

DANGER indicates an imminently hazardous situation which, if not avoided, will result in death or serious injury.

⚠ WARNING

WARNING indicates a potentially hazardous situation which, if not avoided, could result in death or serious injury.

⚠ CAUTION

CAUTION indicates a potentially hazardous situation which, if not avoided, may result in minor or moderate injury.

CAUTION

CAUTION used without the safety alert symbol indicates a potentially hazardous situation which, if not avoided, may result in property damage.

NOTICE

NOTICE indicates special instructions on installation, operation, or maintenance that are important but not related to personal injury or property damage.

Please read before proceeding

NOTICE

This is a gas appliance and should be installed by a licensed electrician and/or certified gas supplier. Service must be performed by a qualified service installer, service agency or the gas supplier.

⚠ WARNING

If the information in these instructions is not followed exactly, a fire or explosion may result causing property damage, personal injury, or death.

This appliance **MUST NOT** be installed in any location where gasoline or flammable vapors are likely to be present, unless the installation is such to eliminate the probable ignition of gasoline or flammable vapors.

What to do if you smell gas –

- Do not try to light any appliance.
- Do not touch any electric switch; do not use any phone in your building.
- Immediately call your gas supplier from a neighbors phone. Follow the gas supplier's instructions.
- If you cannot reach your gas supplier, call the fire department.

Installation and service must be performed by a qualified installer, service agency, or the gas supplier.

Warranty –

Factory warranty (shipped with unit) does not apply to units improperly installed or improperly operated.

Experience has shown that improper installation or system design, rather than faulty equipment, is the cause of most operating problems.

1. Excessive water hardness causing a lime/scale build-up in the copper tube is not the fault of the equipment and is not covered under the manufacturer's warranty (see *Water Treatment and Water Chemistry*).
2. Excessive pitting and erosion on the inside of the copper tube may be caused by too much water velocity through the tubes and is not covered by the manufacturer's warranty (see *Boiler Flow Rates and Temperature Rise for flow requirements*).

⚠ WARNING

Improper installation, adjustment, alteration, service or maintenance can cause injury or property damage. Refer to this manual for assistance or additional information, consult a qualified installer, service agency or the gas supplier.

Checking equipment –

Upon receiving equipment, check for signs of shipping damage. Pay particular attention to parts accompanying the appliances which may show signs of being hit or otherwise being mishandled. Verify total number of pieces shown on packing slip with those actually received. In case there is damage or a shortage, immediately notify the carrier.

Do not use this appliance if any part has been under water. The possible damage to a flooded appliance can be extensive and present numerous safety hazards. Any appliance that has been under water must be replaced.

⚠ Owner warning –

The information contained in this manual is intended for use by qualified professional installers, service technicians, or gas suppliers. **Consult your local expert for proper installation or service procedures.**

NOTICE

Consult and follow all local Building and Fire Regulations and other Safety Codes that apply to this installation. Consult local gas utility company to authorize and inspect all gas and flue connections.

A gas appliance that draws combustion air from the equipment room where it is installed must have a supply of fresh air circulating around it during burner operation for proper gas combustion and proper venting.

⚠ WARNING

Should overheating occur or the gas supply fail to shut off, do not turn off or disconnect the electrical supply to the pump. Instead, shut off the gas supply at a location external to the appliance.

Prevention of freezing –

Heat exchangers and headers damaged by freezing are not covered by warranty.

See Section 7, *Startup - Freeze Protection* for more information.

Please read before proceeding

⚠ WARNING

To minimize the possibility of serious personal injury, fire, or damage to your appliance, never violate the following safety rules:

1. Boilers and water heaters are heat producing appliances. To avoid damage or injury, do not store materials against the appliance or the vent-air intake system. Use proper care to avoid unnecessary contact (especially children) with the appliance and vent-air intake components.
2. Never cover your appliance, lean anything against it, store trash or debris near it, stand on it or in any way block the flow of fresh air to your appliance.
3. UNDER NO CIRCUMSTANCES must flammable materials such as gasoline or paint thinner be used or stored in the vicinity of this appliance, vent-air intake system or any location from which fumes could reach the appliance or vent-air intake system.

Codes –

The equipment shall be installed in accordance with those installation regulations in force in the local area where the installation is to be made. These shall be carefully followed in all cases. Authorities having jurisdiction shall be consulted before installations are made. In the absence of such requirements, the installation shall conform to the latest edition of the National Fuel Gas Code, ANSI Z223.1. Where required by the authority having jurisdiction, the installation must conform to American Society of Mechanical Engineers Safety Code for Controls and Safety Devices for Automatically Fired Boilers, ASME CSD-1. All boilers conform to the latest edition of the ASME Boiler and Pressure Vessel Code, Section IV. Where required by the authority having jurisdiction, the installation must comply with the Canadian Gas Association Code, CAN/CGA-B149.1 and/or B149.2 and/or local codes. This appliance meets the safe lighting performance criteria with the gas manifold and control assembly provided, as specified in the ANSI standards for gas-fired hot water boilers, ANSI Z21.13 and gas water heaters, ANSI Z21.10.3.

Ratings



 Power-fin I=B=R Rating					Other Specifications			
Model Number B = Boiler F = Water Heater Note: Change "N" to "L" for L.P. gas models.	Input MBH (Note 4)		Gross Output MBH (Note 1)	Net I=B=R Ratings Water, MBH (Note 2)	Appliance Water Content Gallons	Water Connections	Gas Connections	Air / Vent Sizes (Note 3)
	Min	Max						
P(B/F)N0502-M9	100	500	425	370	3.50	2.5"	1"	5" - 4"
P(B/F)N0752-M9	150	750	638	554	4.00	2.5"	1 1/4"	5" - 5"
P(B/F)N1002-M9	200	1000	850	739	4.50	2.5"	1 1/4"	6" - 6"
P(B/F)N1302-M9	260	1300	1105	961	5.00	2.5"	1 1/4"	6" - 8"
P(B/F)N0502-F9	N/A	500	425	370	3.50	2.5"	1"	5" - 7"
P(B/F)N0752-F9	N/A	750	638	554	4.00	2.5"	1 1/4"	5" - 9"
P(B/F)N1002-F9	N/A	1000	850	739	4.50	2.5"	1 1/4"	6" - 10"
P(B/F)N1302-F9	N/A	1300	1105	961	5.00	2.5"	1 1/4"	6" - 12"
P(B/F)N1501-M9	300	1500	1275	1109	5.50	2.5"	1 1/2"	6" - 6"
P(B/F)N1701-M9	340	1700	1445	1257	5.75	2.5"	1 1/2"	7" - 7"
P(B/F)N2001-M9	440	2000	1700	1478	6.13	2.5"	1 1/2"	8" - 8"
P(B/F)N1501-B9	900	1500	1260	1096	5.50	2.5"	1 1/2"	6" - 12"
P(B/F)N1701-B9	1020	1700	1428	1242	5.75	2.5"	1 1/2"	7" - 14"
P(B/F)N2001-B9	1200	2000	1680	1461	6.13	2.5"	1 1/2"	8" - 14"

NOTICE Maximum allowed working pressure is located on the rating plate.

Notes:

- The ratings are based on standard test procedures prescribed by the United States Department of Energy.
- Net I=B=R ratings are based on net installed radiation of sufficient quantity for the requirements of the building and nothing need be added for normal piping and pickup. Ratings are based on a piping and pickup allowance of 1.15.
- Power-fins require special gas venting. Use only the vent materials and methods specified in the Power-fin Installation and Operation Manual.
- The Power-fin is equipped for operation up to 2000 feet, and including up to 4000 feet, with no field adjustments. The appliance output ratings up to 4000 feet shall be reduced by 4% for each 1000 feet above sea level. For operation above 4000 feet, consult the factory.

The Power-fin - How it works...

1. Heat exchanger

The heat exchanger allows system water to flow through specially designed tubes for maximum heat transfer. The glass lined headers and copper finned tubing are encased in a jacket that contains the combustion process.

2. Heat exchanger access cover

The heat exchanger access cover is a stainless steel door which allows access for service, maintenance, and removal of the heat exchanger from inside the combustion chamber.

3. Blower

The blower pulls in air and gas through the venturi (see item 5) and injects the fuel/air mixture into the burner, where they burn inside the combustion chamber.

4. Gas valve

The gas valve allows the proper amount of gas to pass into the burner for combustion. The gas valve on the Power-fin works under a negative pressure so gas should only be pulled through the valve when the blower is in operation.

5. Venturi

The venturi attaches to the inlet (or suction) side of the blower and generates the negative pressure needed by the gas valve.

6. Flue sensor (not shown)

The flue sensor is mounted in the exhaust collar of the unit and monitors the flue gas temperature. If the temperature in the stack exceeds the maximum temperature the unit will shut down to prevent a hazardous condition. In Category I models the flue sensor helps to control the amount of modulation to prevent condensation in the stack.

7. Outlet temperature sensor

This sensor monitors the outlet water temperature. If selected as the controlling sensor, the appliance will maintain set point by adjusting the firing rate of the unit according to this sensor.

8. Inlet temperature sensor

This sensor monitors inlet water temperature. If selected as the controlling sensor, the appliance will maintain set point by adjusting the firing rate of the unit according to this sensor.

9. Temperature and pressure gauge

The temperature and pressure gauge monitors the outlet temperature of the appliance as well as the system water pressure.

10. Electronic display

The electronic display consists of 7 buttons and a dual line 32-character liquid crystal display used to monitor the operation of the heater as well as enter and view the programming of the main control board.

11. Burner (not shown)

The burner is made of a woven fabric over steel screen construction. The burner uses pre-mixed air and gas and provides a wide range of firing rates.

12. Water outlet (system supply)

The water outlet is a 2 1/2" pipe connection that supplies water to the system with connections for a flow switch (see #28), a relief valve (see #25), and a temperature and pressure gauge (boilers only) (see #9).

13. Water inlet (system return)

The water inlet is a 2 1/2" pipe connection that receives water from the system and delivers it to the heat exchanger.

14. Gas connection pipe

The gas pipe connection on this appliance is 1", 1 1/4", or 1 1/2" NPT. To deliver the correct amount of gas volume to the appliance it may be necessary to have a larger gas line reduced to 1 1/4" at the appliance. Please reference the National Fuel Gas Code charts for more details.

15. SMART SYSTEM Control Module

The SMART System Control Module is the main control for the appliance. This module contains the programming that operates the blower, gas valve, and pumps in addition to other programmable features.

16. Air intake

The air intake pipe allows fresh air to flow directly to the appliance. The air inlet is part of the filter box assembly where air filtration is accomplished with a standard filter.

17. Line voltage terminal strip

The line voltage terminal strip provides a location to connect all of the line voltage (120 VAC) contact points to the unit.

18. Low voltage connection board

The low voltage connection board provides a location to tie in all of the low voltage contacts to the appliance. This is where most of the external safety devices are connected to the unit such as the louver proving switch.

19. Condensate trap

The condensate trap is designed to prevent flue gases from escaping the appliance through the combustion chamber drain.

20. Access cover - front

The front access cover provides access to the gas train as well as the blower and other key components for service and maintenance.

21. Hot surface igniter (HSI)

The hot surface igniter is a device that is used to ignite the air/gas mixture as well as monitor the performance of the flame during operation. This device acts as a flame sense electrode.

22. Flame inspection window (sight glass) (not shown on Models 502 - 1302)

The flame inspection window is a quartz glass window that allows a visual inspection of the burner and flame during operation.

23. Gas shut off valve (downstream test cock)

The downstream test cock is provided in the gas train to ensure complete shut off of the gas to the burner in case of maintenance, inspection, or testing of the valve.

24. High limit sensor

Device that monitors the outlet water temperature to ensure safe operation. If the temperature exceeds its setting (field adjustable), it will break the control circuit, shutting the appliance down.

25. Relief valve

The relief valve is a safety device that ensures the maximum pressure of the appliance is not exceeded. Boilers operate on pressure only and are shipped from the factory at a rating of 50 PSI. Water heaters operate on temperature and pressure and are shipped standard as 150 PSI and 210°F (98.9°C).

26. Power switch

The power switch is used to engage and disengage power to the appliance on the 120 VAC circuit.

27. Air pressure switch

The air pressure switch is a safety device which ensures proper blower operation. The air pressure switch is wired in series with the low voltage control circuit in such a way that if the fan does not engage or shuts down prematurely the device will break the control circuit and the unit will shut down.

The Power-fin - How it works... *(continued)*

28. Flow switch

The flow switch is a safety device that ensures flow through the heat exchanger during operation. This appliance is low mass and should never be operated without flow. The flow switch makes contact when flow is detected and allows the unit to operate. If flow is discontinued during operation for any reason the flow switch will break the control circuit and the unit will shut down.

29. Drain port(s)

Location from which the heat exchanger can be drained.

30. Ventilation fan

Provides air circulation around the controls inside the unit.

31. Manual shutoff valve

Manual valve used to isolate the unit from the gas supply.

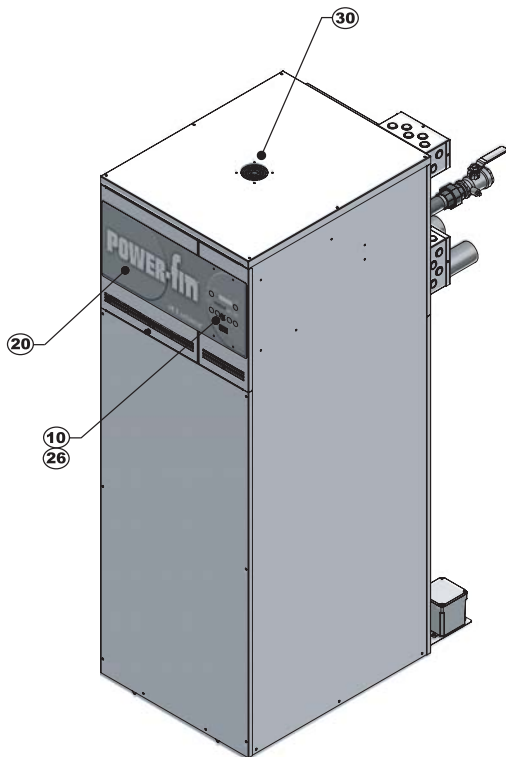

Models 502 - 1302 Front View

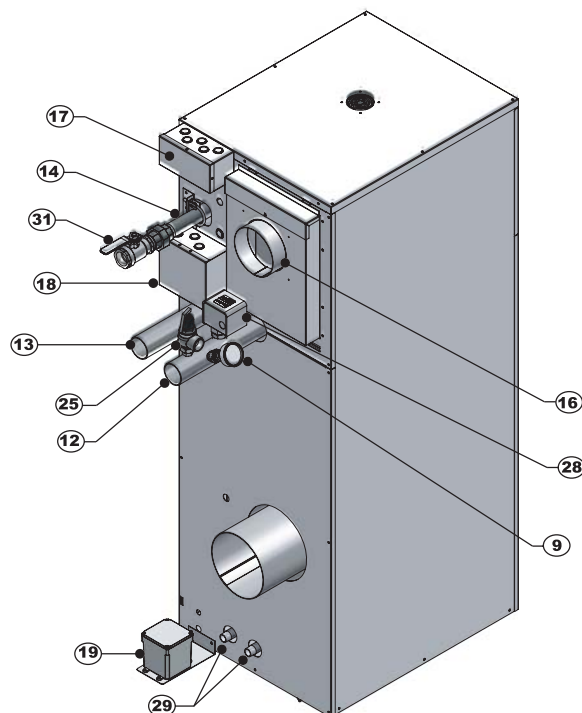

Models 502 - 1302 Rear View

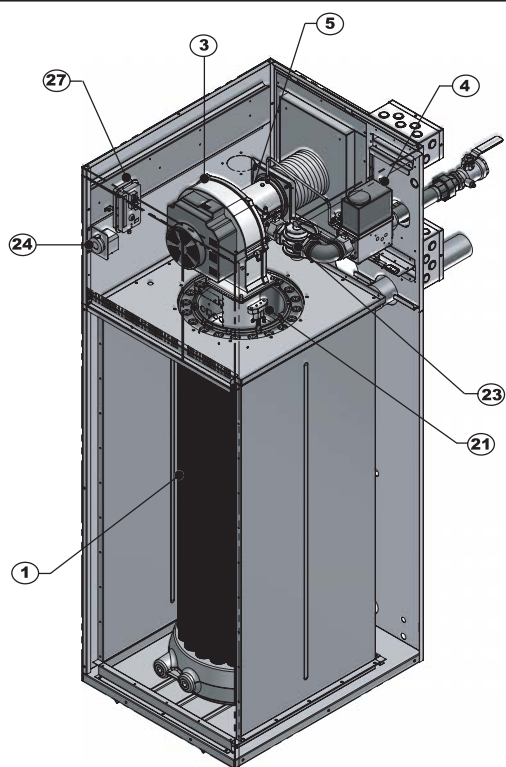

Models 502 - 1302 Right Side (inside unit) - M9

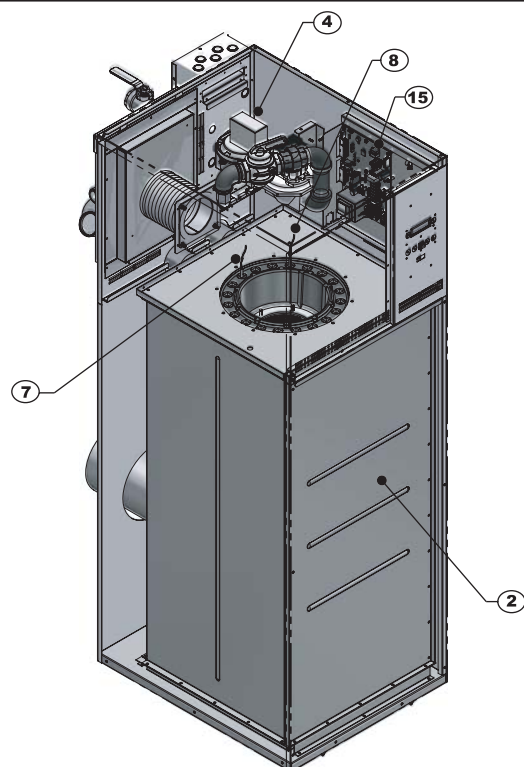

Models 502 - 1302 Left Side (inside unit) - F9

The Power-fin - How it works...

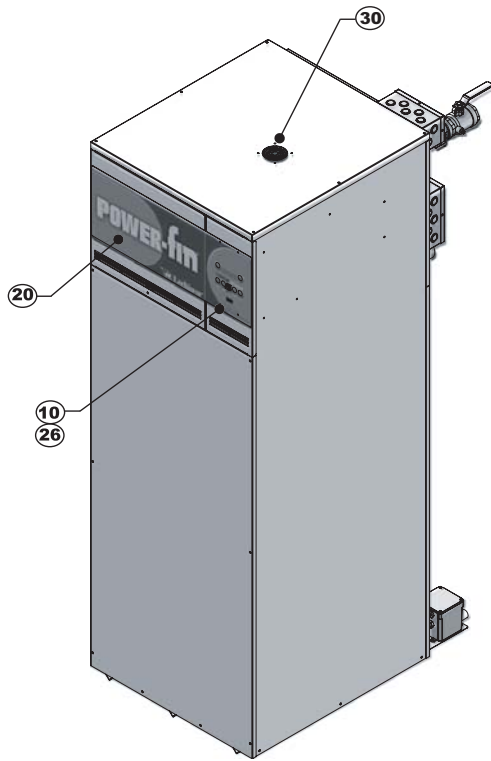

Models 1501 - 2001 Front View

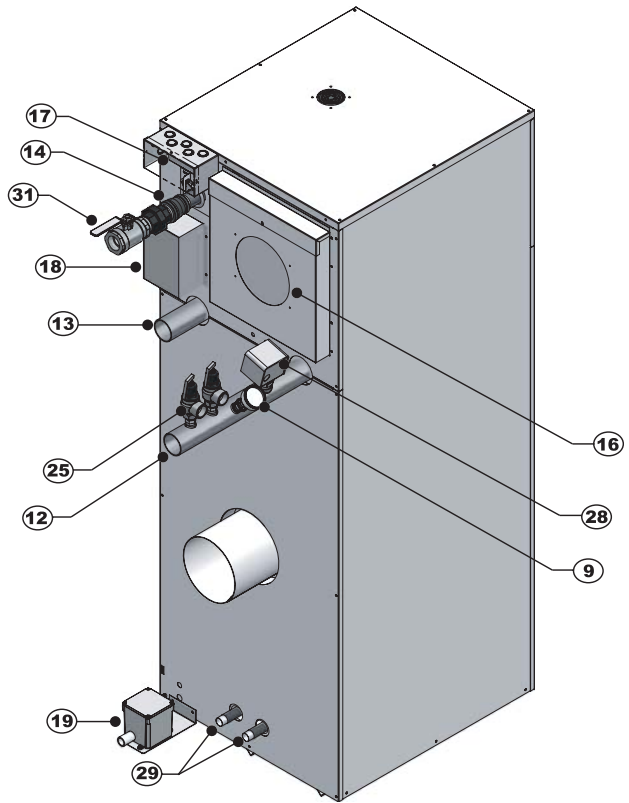

Models 1501 - 2001 Rear View

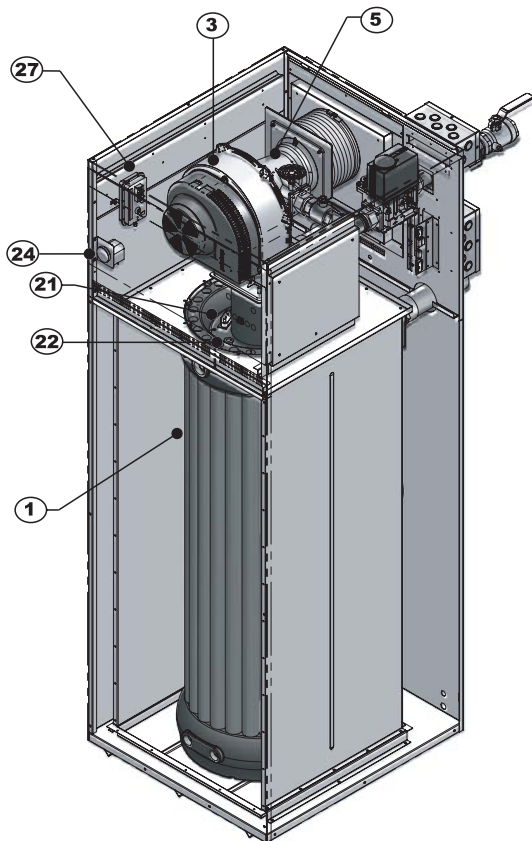

Models 1501 - 2001 Right Side (inside unit)

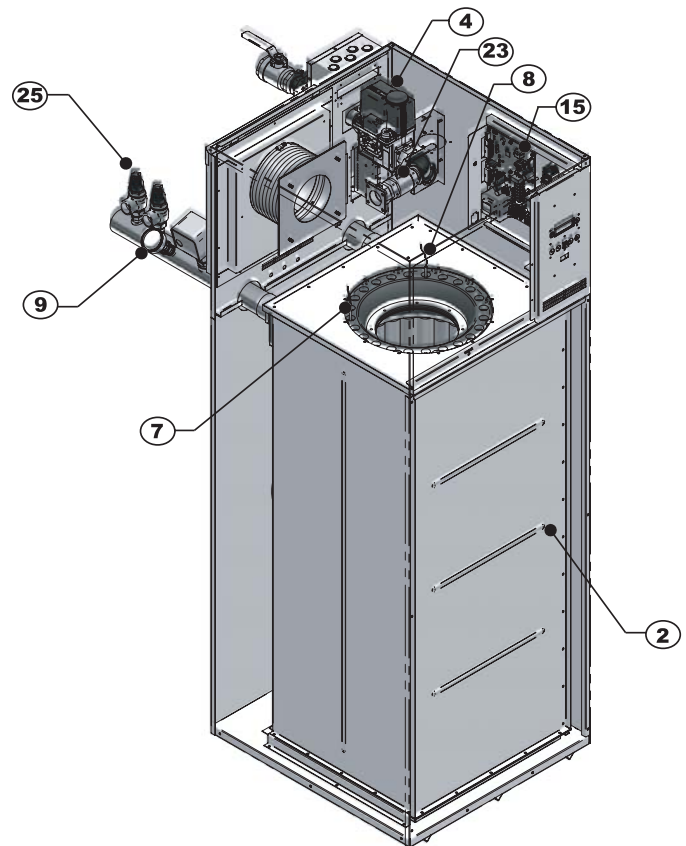

Models 1501 - 2001 Left Side (inside unit)

1 Determine unit location

Location of unit

1. Locate the appliance so that if water connections should leak, water damage will not occur. When such locations cannot be avoided, it is recommended that a suitable drain pan, adequately drained, be installed under the unit. The pan must not restrict combustion airflow. Under no circumstances is the manufacturer to be held responsible for water damage in connection with this unit, or any of its components.
2. The appliance must be installed so that the ignition system components are protected from water (dripping, spraying, rain, etc.) during appliance operation and service (circulator replacement, control replacement, etc.).
3. Appliances located in a residential garage and in adjacent spaces that open to the garage and are not part of the living space of a dwelling unit must be installed so that all burners and burner ignition devices have a minimum clearance of not less than 18" (46 cm) above the floor. The appliance must be located or protected so that it is not subject to physical damage by a moving vehicle.
4. DO NOT install this appliance in any location where gasoline or flammable vapors are likely to be present.
5. The appliance must be installed on a level floor. Combustible floor locations may be used. Maintain required clearances from combustible surfaces.
6. The appliance must not be installed on carpet.
7. The appliance must be installed indoors where it is protected from exposure to wind, rain, and weather.
8. This appliance may condense the products of combustion when operating at water temperatures below 140°F (60°C). Ensure that the appliance is located near an acceptable drain where condensate that may form in the venting system may be properly collected and disposed.
9. Access to rear of appliance MUST be maintained.

Recommended service clearances

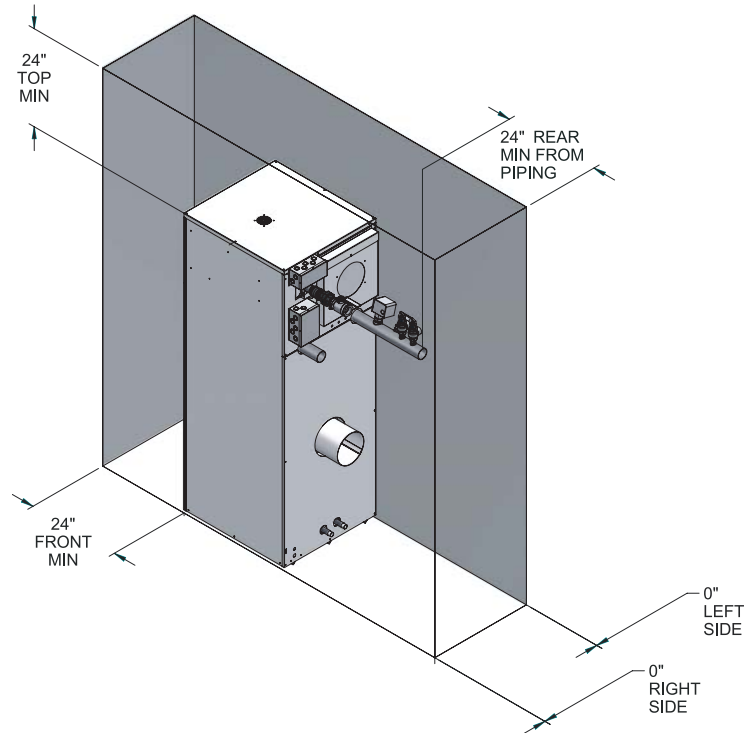

Figure 1-1_Recommended Service Clearances

TABLE - 1A CLEARANCES FROM COMBUSTIBLE CONSTRUCTION	
Location	Clearances
Right Side	0"
Rear	6" (15cm) (Minimum 24" (0.61m) suggested for service to pump and components)
Left Side	0"
Front - Alcove*	(Minimum 24" (0.61m) suggested for service)
Top	6" (15cm) (Minimum 24" (0.61m) suggested for service)
Flue	2" (51mm)
Hot Water Pipes	1" (25.4mm)

*An Alcove is a closet without a door.

NOTICE Clearances from combustible construction are noted on the appliance rating plate.

1 Determine unit location

Maintain minimum specified clearances for adequate operation. All installations must allow sufficient space for servicing the vent connections, water pipe connections, piping and other auxiliary equipment, as well as the appliance. The clearance labels on each appliance note the same service and combustible clearance requirements as shown above.

Multiple appliances may be installed in a modular boiler or water heater installation. Multiple appliances may be installed side by side with no clearance between adjacent appliances because this appliance is approved for zero clearance from combustible surfaces and no service access is required from the sides.

Consult the *Venting* section of this manual for specific installation instructions for the appropriate type of venting system that you will be using. Direct Vent and DirectAire venting systems require installation with Category IV flue pipe, sealed air inlet pipe, and air inlet caps, which must meet the manufacturer's specifications.

Combustion and ventilation air requirements for appliances drawing air from the equipment room

Provisions for combustion and ventilation air must be in accordance with Air for Combustion and Ventilation, of the latest edition of the National Fuel Gas Code, ANSI Z223.1, in Canada, the latest edition of CGA Standard B149 Installation Code for Gas Burning Appliances and Equipment, or applicable provisions of the local building codes.

The equipment room MUST be provided with properly sized openings to assure adequate combustion air and proper ventilation.

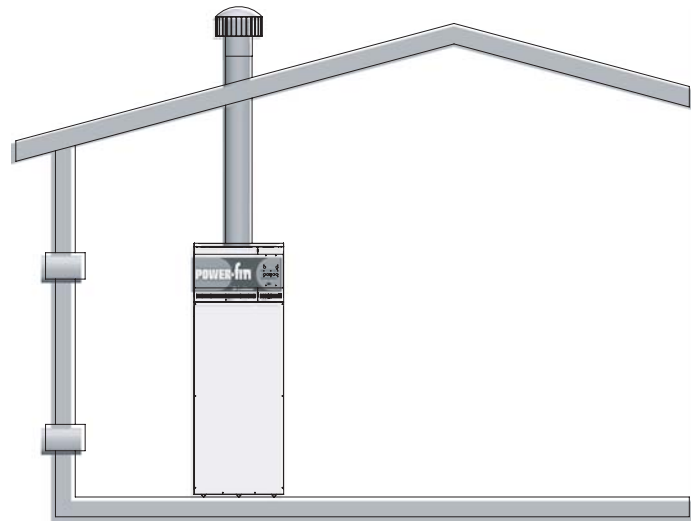

Figure 1-2_Combustion Air Direct from Outside

1. If air is taken directly from outside the building with no duct, provide two permanent openings to the equipment room (see FIG. 1-2):
 - (a) Combustion air opening, with a minimum free area of one square inch per 4000 Btu/hr input (5.5 cm² per kW). This opening must be located within 12" (30 cm) of the bottom of the enclosure.
 - (b) Ventilation air opening, with a minimum free area of one square inch per 4000 Btu/hr input (5.5 cm² per kW). This opening must be located within 12" (30 cm) of the top of the enclosure.

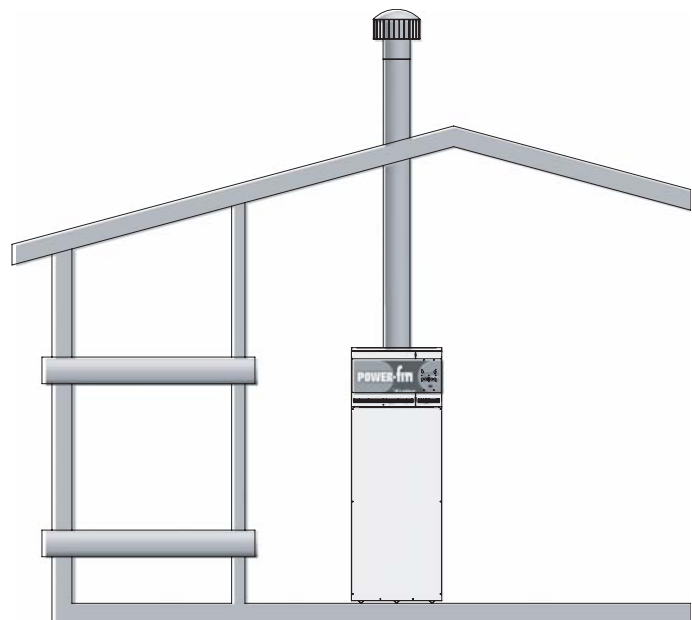

Figure 1-3_Combustion Air Through Ducts

1 Determine unit location *(continued)*

- If combustion and ventilation air is taken from the outdoors using a duct to deliver the air to the equipment room, each of the two openings should be sized based on a minimum free area of one square inch per 2000 Btu/hr (11 cm² per kW) of input (see FIG. 1-3).

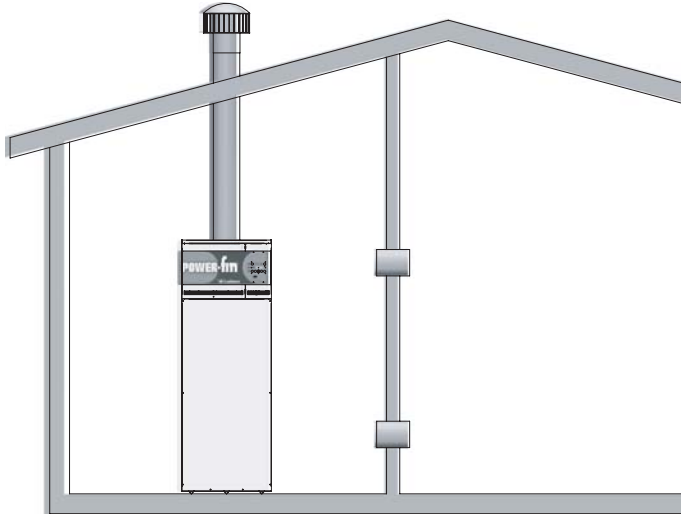

Figure 1-4_Combustion Air from Interior Space

- If air is taken from another interior space, each of the two openings specified above should have a net free area of one square inch for each 1000 Btu/hr (22 cm² per kW) of input, but not less than 100 square inches (645 cm²) (see FIG. 1-4).

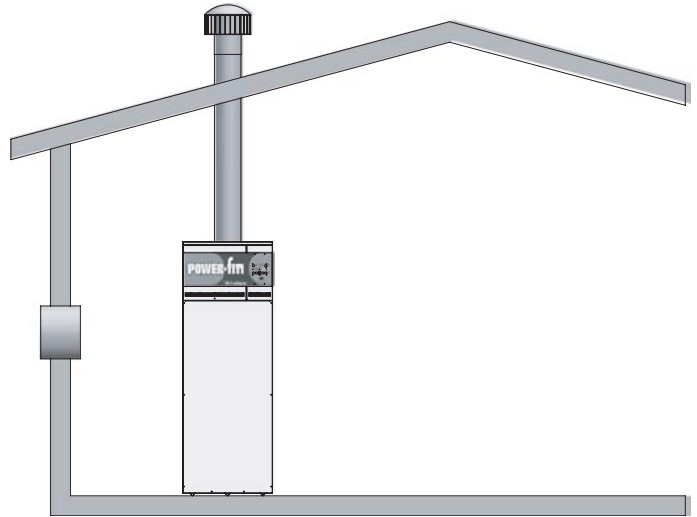

Figure 1-5_Combustion Air from Outside - Single Opening

- If a single combustion air opening is provided to bring combustion air in directly from the outdoors, the opening must be sized based on a minimum free area of one square inch per 3000 Btu/hr (7 cm² per kW). This opening must be located within 12" (30 cm) of the top of the enclosure (see FIG. 1-5).

TABLE - 1B MINIMUM RECOMMENDED COMBUSTION AIR SUPPLY TO EQUIPMENT ROOM							
Model Number	*Outside Air from 2 Openings Directly from Outdoors		*Outside Air from 1 Opening Directly from Outdoors, in ²	Inside Air from 2 Ducts Delivered from Outdoors		Inside Air from 2 Ducts Delivered from Interior Space	
	Top Opening, in ²	Bottom Opening, in ²		Top Opening, in ²	Bottom Opening, in ²	Top Opening, in ²	Bottom Opening, in ²
502	125 (807 cm ²)	125 (807 cm ²)	167 (1077 cm ²)	250 (1613 cm ²)	250 (1613 cm ²)	500 (3226 cm ²)	500 (3226 cm ²)
752	188 (1213 cm ²)	188 (1213 cm ²)	250 (1613 cm ²)	375 (2420 cm ²)	375 (2420 cm ²)	750 (4839 cm ²)	750 (4839 cm ²)
1002	250 (1613 cm ²)	250 (1613 cm ²)	333 (2149 cm ²)	500 (3226 cm ²)	500 (3226 cm ²)	1000 (6452 cm ²)	1000 (6452 cm ²)
1302	325 (2097 cm ²)	325 (2097 cm ²)	433 (2794 cm ²)	650 (4194 cm ²)	650 (4194 cm ²)	1300 (8388 cm ²)	1300 (8388 cm ²)
1501	375 (2420 cm ²)	375 (2420 cm ²)	500 (3226 cm ²)	750 (4839 cm ²)	750 (4839 cm ²)	1500 (9678 cm ²)	1500 (9678 cm ²)
1701	425 (2742 cm ²)	425 (2742 cm ²)	567 (3658 cm ²)	850 (5484 cm ²)	850 (5484 cm ²)	1700 (10968 cm ²)	1700 (10968 cm ²)
2001	500 (3226 cm ²)	500 (3226 cm ²)	667 (4303 cm ²)	1000 (6452 cm ²)	1000 (6452 cm ²)	2000 (12904 cm ²)	2000 (12904 cm ²)

*Outside air openings shall directly communicate with the outdoors. When combustion air is drawn from the outside through a duct, the net free area of each of the two openings must have twice (2 times) the free area required for Outside Air/2 Openings. The above requirements are for the boiler only; additional gas fired appliances in the equipment room will require an increase in the net free area to supply adequate combustion air for all appliances.

1 Determine unit location

Combustion air requirements are based on the latest edition of the National Fuel Gas Code, ANSI Z223.1; in Canada refer to the latest edition of CGA Standard CAN B149.1 or B149.2. Check all local code requirements for combustion air.

All dimensions based on net free area in square inches. Metal louvers or screens reduce the free area of a combustion air opening a minimum of approximately 25%. Check with louver manufacturers for exact net free area of louvers. Where two openings are provided, one must be within 12" (30cm) of the ceiling and one must be within 12" (30cm) of the floor of the equipment room. Each opening must have net free area as specified in the chart on page 11 (Table 1B). Single openings shall commence within 12" (30cm) of the ceiling.

CAUTION

Under no circumstances should the equipment room ever be under negative pressure. Particular care should be taken where exhaust fans, attic fans, clothes dryers, compressors, air handling units, etc., may take away air from the unit.

The combustion air supply must be completely free of any flammable vapors that may ignite or chemical fumes which may be corrosive to the appliance. Common corrosive chemical fumes which must be avoided are fluorocarbons and other halogenated compounds, most commonly present as refrigerants or solvents, such as Freon, trichlorethylene, perchlorethylene, chlorine, etc. These chemicals, when burned, form acids which quickly attack the heat exchanger finned tubes, headers, flue collectors, and the vent system.

The result is improper combustion and a non-warrantable, premature appliance failure.

EXHAUST FANS: Any fan or equipment which exhausts air from the equipment room may deplete the combustion air supply and/or cause a downdraft in the venting system. Spillage of flue products from the venting system into an occupied living space can cause a very hazardous condition that must be immediately corrected. If a fan is used to supply combustion air to the equipment room, the installer must make sure that it does not cause drafts which could lead to nuisance operational problems with the appliance.

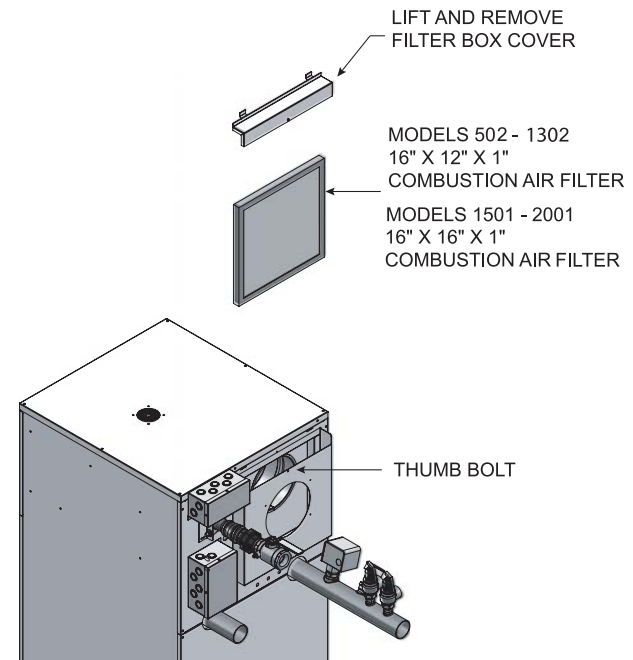

Figure 1-6 Filter Access

Combustion air filter

This unit has a standard air filter located at the combustion air inlet as shown above in FIG. 1-6. This air filter is provided to help ensure clean air is used for the combustion process. Check this filter every month and replace when it becomes dirty. The filter size on Models 502 -1302 is 16" x 12" x 1" (40.6cm x 30.5cm x 2.5cm) and for Models 1501 - 2001 it's 16" x 16" x 1" (40.6cm x 40.6cm x 2.5cm). You can find these commercially available filters at any home center or HVAC supply store. Follow the steps below when replacing the combustion air filter:

1. Locate the combustion air filter box mounted on the rear of the appliance.
2. Locate the flat thumb bolt at the top of the air filter box and turn it a 1/4 turn counterclockwise to align it with the slot in the air filter box.
3. Lift and remove the air filter box cover to gain access to the air filter.
4. Slide the air filter out the top of the air filter box.
5. Inspect the air filter for dirt and debris, replace if necessary.
6. Replace the air filter and the air filter box cover. Turn the thumb bolt clockwise a 1/4 turn to secure the air filter box cover to the air filter box.

NOTICE

During construction the air filter should be checked more frequently to ensure it does not become clogged with combustion dirt and debris.

CAUTION

Sustained operation of an appliance with a clogged burner may result in nuisance operational problems, bad combustion, and non-warrantable component failures.

2 Venting

BEFORE YOU BEGIN

Identify your appliance's vent system:

This manual covers venting requirements for CAT II/IV and CAT I models. Be sure to correctly identify the type of vent system your appliance requires before proceeding.

Category II/IV Models: See page 15

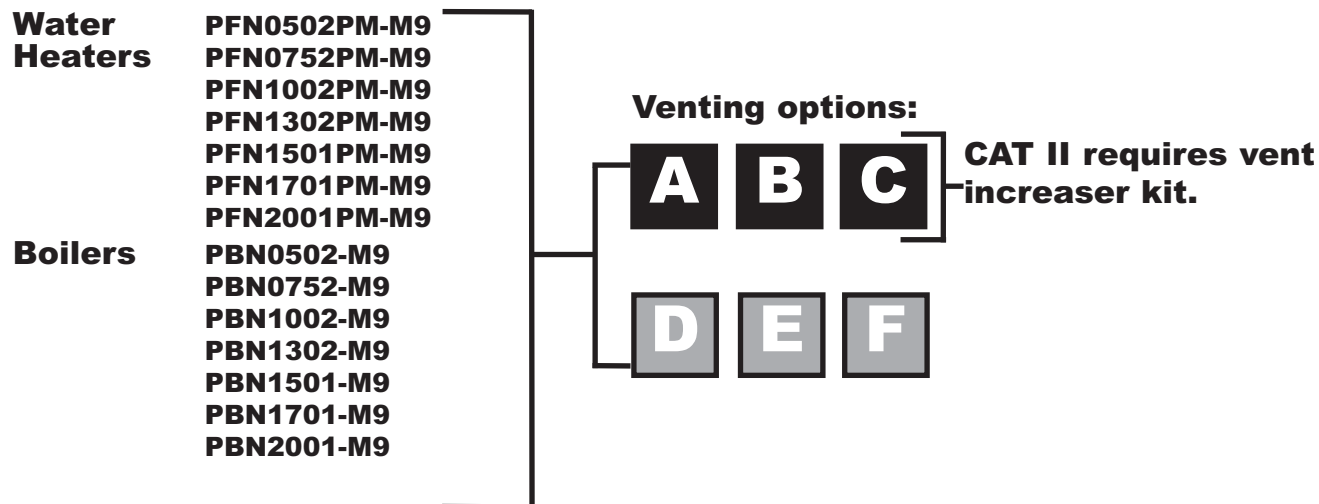

Category I Models: See page 19

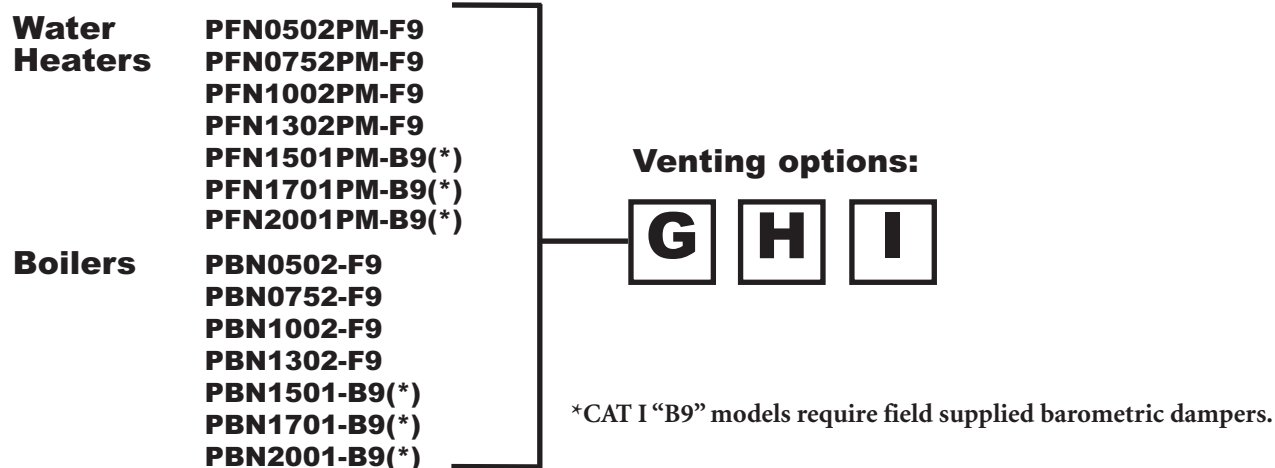

DANGER Failure to use correct venting materials can result in loss of life from flue gas spillage into working or living space.

Venting Category Definitions: (Reference National Fuel Gas Code ANSI Z223.1)

CAT IV: Positive pressure condensing

An appliance that operates with a positive vent static pressure with a vent gas temperature that may cause excessive condensate production in the vent.

CAT II: Negative pressure condensing

An appliance that operates with a non-positive vent static pressure with a vent gas temperature that may cause excessive condensate production in the vent.

CAT I: Negative pressure non-condensing

An appliance that operates with a non-positive vent static pressure with a vent gas temperature that avoids excessive condensate production in the vent.

2 Venting

Vent Materials:

Category II/IV Vent Material Suppliers:

Category II/IV flue pipe materials and vent adapters (see FIG. 2-1) can be obtained from the following manufacturers:

Heat-Fab Inc., Saf-T CI Vent with AL29-4C stainless steel

Protech Systems Inc., Fas N Seal Vent with AL29-4C stainless steel

Flex-L International Inc., StaR 34 Vent with AL29-4C stainless steel

Metal-Fab Inc., Corr/Guard Vent with AL29-4C stainless steel

Z-Flex, Z-Vent with AL29-4C stainless steel

Or other listed Category IV vent systems suitable for a condensing, positive pressure, gas fired appliance.

A Category IV flue **MUST** have all vent joints and seams sealed gastight and have provisions for a drain to properly collect and dispose of condensate that may occur in the venting system.

Category II/IV Vent Adapter "Field Supplied"

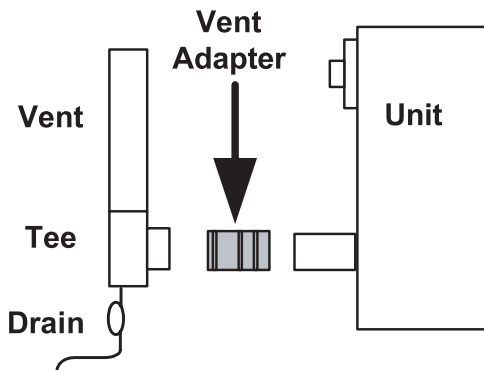

Figure 2-1_Category IV Vent Adapter

TABLE - 2A FLUE ADAPTER SIZES	
MODEL	FLUE ADAPTER SIZE
PB/FN0502-M9	4"
PB/FN0752-M9	5"
PB/FN1002-M9	6"
PB/FN1302-M9	8"
PB/FN1501-M9	6"
PB/FN1701-M9	7"
PB/FN2001-M9	8"

Category II In increaser Kit "Must be purchased from manufacturer"

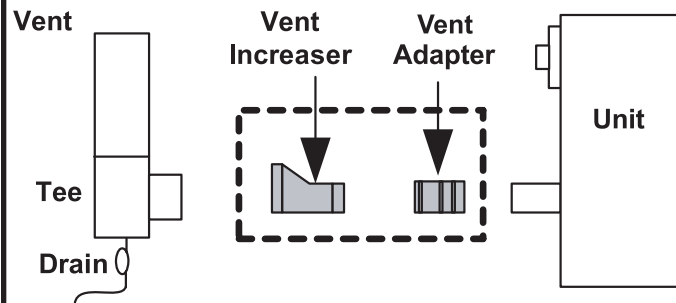

Figure 2-2_Category IV to II Conversion Kit

TABLE - 2B CATEGORY IV TO CATEGORY II CONVERSION KITS		
MODEL	FLUE SIZE	KIT NUMBER
PB/FN0502-M9	4" to 7"	KIT3131
PB/FN0752-M9	5" to 9"	KIT3132
PB/FN1002-M9	6" to 10"	KIT3133
PB/FN1302-M9	8" to 12"	KIT3134
PB/FN1501-M9	6" to 8"	KIT3106
PB/FN1701-M9	7" to 9"	KIT3107
PB/FN2001-M9	8" to 10"	KIT3108

Category I Vent Material Suppliers:

Category I venting materials are readily available from your local plumbing/HVAC supply houses.

2 Venting *(continued)*

Condensing Vent Options: CAT II & IV

(CAT II vent options A, B, & C requires an adapter kit - see page 14)

A

Vertical vent with combustion air from equipment room - see page 16.

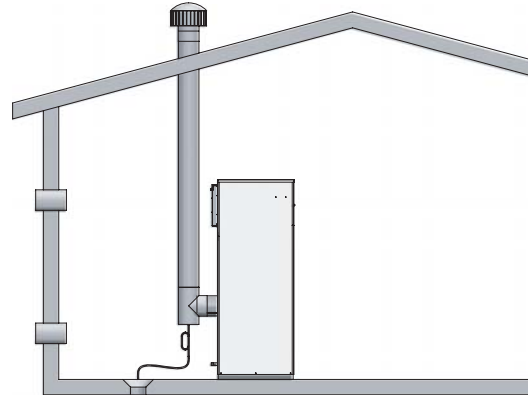

CAT II/IV

CAT II requires an adapter kit.

See page 14.

D

Sidewall termination with combustion air from equipment room - see page 17.

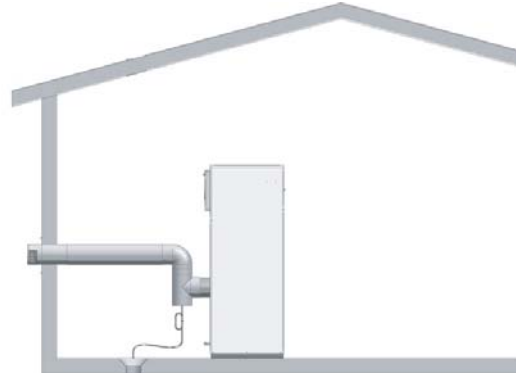

CAT IV

B

Vertical Direct Vent installation with rooftop combustion air inlet - see page 16.

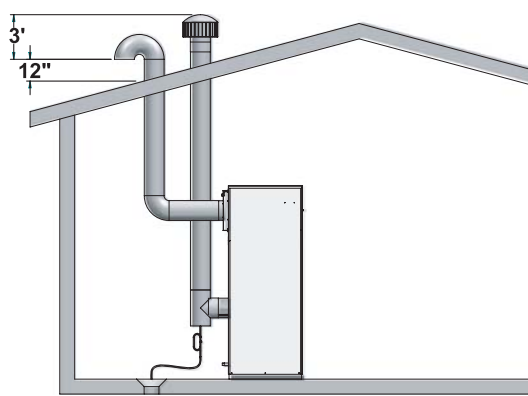

CAT II/IV

CAT II requires an adapter kit.

See page 14.

E

Horizontal Direct Vent installation with sidewall combustion air inlet - see page 18.

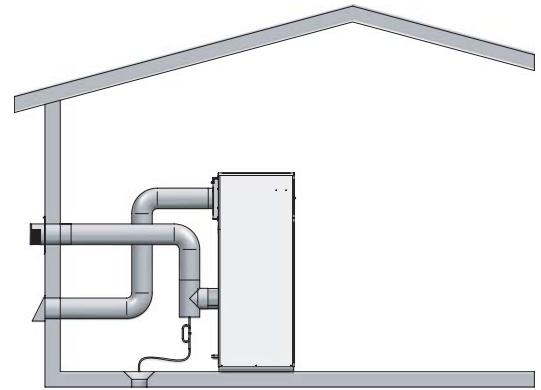

CAT IV

C

Vertical DirectAire installation with sidewall combustion air inlet - see page 17.

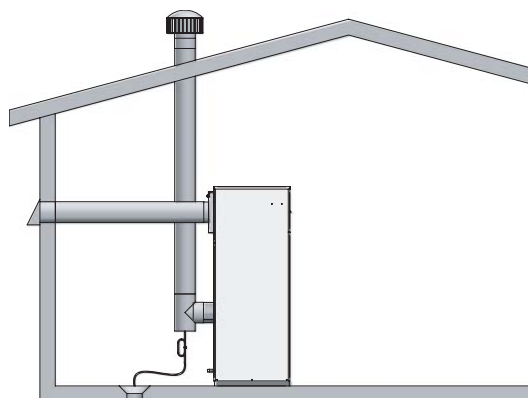

CAT II/IV

CAT II requires an adapter kit.

See page 14.

F

Horizontal DirectAire installation with vertical combustion air inlet - see page 18.

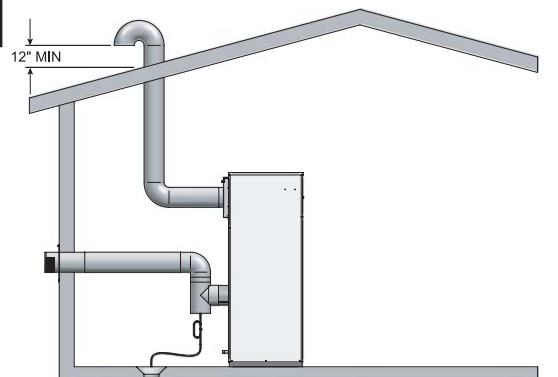

CAT IV

2 Venting

Condensing vent options: CAT II & IV (CAT II vent options A, B, & C requires an adapter kit - see page 14)



CAT II/IV

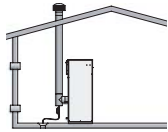

CAT II requires an adapter kit. See page 14.

Vertical vent with combustion air from equipment room - see page 15.

The flue outlet terminates on the rooftop.

The termination point for the flue products must follow the vertical vent termination clearance requirements on pages 27 and 28. These units can be identified by the Category IV and the control number M9 as noted on the unit's rating plate.

The flue from this Category IV appliance must have all vent joints and seams sealed gastight. A Category IV vent system has specific vent material and installation requirements.

The flue products in the vent system may be cooled below their dew point and form condensate in the flue. The materials used for a Category IV vent must be resistant to any corrosive damage from flue gas condensate. The flue from a Category IV vent system must have a condensate drain with provisions to properly collect and dispose of any condensate that may occur in the venting system.

Follow all requirements in the *General Venting* and *Category IV General Venting* sections for proper installation and for venting flue products to the outdoors with a vertical termination (see pages 22 and 23).

TABLE - 2C VENT TERMINATION SIZES					
MODEL	CAT II VENT SIZE	CAT IV VENT SIZE	MODEL	CAT II VENT SIZE	CAT IV VENT SIZE
PB/FN0502-M9	7"	4"	PB/FN1501-M9	8"	6"
PB/FN0752-M9	9"	5"	PB/FN1701-M9	9"	7"
PB/FN1002-M9	10"	6"	PB/FN2001-M9	10"	8"
PB/FN1302-M9	12"	8"	--	--	--



CAT II/IV

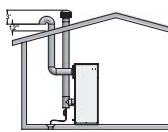

CAT II requires an adapter kit. See page 14.

Vertical direct vent installation with rooftop combustion air inlet - see page 15.

The Vertical Direct Vent system is installed with a Category IV flue and a separate combustion air pipe to the outdoors. The flue outlet and combustion air intake must both terminate on the rooftop.

The termination point for the flue products must follow the vertical vent termination clearance requirements on pages 27 and 28. These units can be identified by the Category IV and the control number M9 as noted on the unit's rating plate.

The optional Direct Vent system requires the installation of specific venting materials that are purchased locally.

Follow all requirements in the *General Venting* and *Category IV General Venting* sections for proper installation and for venting flue products to the outdoors with a vertical termination (see pages 22 and 23).

The Vertical Direct Vent system requires the installation of an additional pipe to supply combustion air from outdoors directly to the appliance. Follow all requirements under the *Combustion Air Inlet* section on pages 25 and 26.

TABLE - 2D AIR & VENT TERMINATION SIZES									
MODEL	CAT II		CAT IV		MODEL	CAT II		CAT IV	
	AIR SIZE	VENT SIZE	AIR SIZE	VENT SIZE		AIR SIZE	VENT SIZE	AIR SIZE	VENT SIZE
PB/FN0502-M9	5"	7"	5"	4"	PB/FN1501-M9	6"	8"	6"	6"
PB/FN0752-M9	5"	9"	5"	5"	PB/FN1701-M9	7"	9"	7"	7"
PB/FN1002-M9	6"	10"	6"	6"	PB/FN2001-M9	8"	10"	8"	8"
PB/FN1302-M9	6"	12"	6"	8"	--	--	--	--	--

2 Venting *(continued)*

Condensing vent options: CAT II & IV

(CAT II vent options A, B, & C requires an adapter kit - see page 14)



CAT II/IV

DirectAir Vertical installation with sidewall combustion air inlet - see page 15.

The DirectAir Vertical with a Sidewall Combustion Air Vent system terminates the flue at the rooftop and air inlet at the sidewall. The flue outlet and combustion air intake terminate in different pressure zones.

The optional DirectAir vent system requires the installation of specific venting materials that are purchased locally.

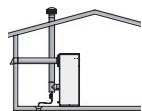

The termination point for the flue products must follow the vertical vent termination clearance requirements on pages 27 and 28. These units can be identified by the Category IV and the control number M9 as noted on the unit's rating plate.

CAT II requires an adapter kit.

See page 14.

Follow all requirements in the *General Venting* and *Category IV General Venting* sections for proper installation and for venting flue products to the outdoors with a vertical termination (see pages 22 and 23).

The DirectAir Vertical system requires the installation of an additional pipe to supply combustion air from outdoors directly to the appliance. Follow all requirements under the *Combustion Air Inlet* section on pages 25 and 26.

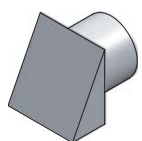

Air Inlet Cap

Sidewall combustion air inlet: The air inlet cap for the sidewall air inlet must be purchased from the appliance manufacturer.

The part numbers for the required sidewall air inlet cap kit are listed by model. Each kit includes the special combustion air inlet cap for installation on an exterior sidewall. The sidewall air inlet cap supplied in the kit is sized to provide combustion air for a single appliance only.

**TABLE - 2E
AIR INLET CAP TERMINATIONS**

MODEL	CAT II		CAT IV		CAT IV KIT NUMBER	MODEL	CAT II		CAT IV		CAT IV KIT NUMBER
	AIR SIZE	VENT SIZE	AIR SIZE	VENT SIZE			AIR SIZE	VENT SIZE	AIR SIZE	VENT SIZE	
PB/FN0502-M9	5"	7"	5"	4"	SAK3003	PB/FN1501-M9	6"	8"	6"	6"	SAK3004
PB/FN0752-M9	5"	9"	5"	5"	SAK3003	PB/FN1701-M9	7"	9"	7"	7"	SAK3005
PB/FN1002-M9	6"	10"	6"	6"	SAK3004	PB/FN2001-M9	8"	10"	8"	8"	SAK3006
PB/FN1302-M9	6"	12"	6"	8"	SAK3004	--	--	--	--	--	--



CAT IV

Sidewall termination with combustion air from equipment room - see page 15.

The connection from the appliance flue outlet to the sidewall vent cap **MUST** be made with listed Category IV vent materials and accessories. The installer must supply suitable vent pipe material. The sidewall vent cap must be purchased from the appliance manufacturer.



The sidewall vent cap kit includes the wall penetration assembly and the discharge screen assembly. All required Category IV vent pipe and fittings must be purchased locally.

The termination point for the flue products must follow the sidewall vent termination clearance requirements on pages 29 and 30. These units can be identified by the Category IV and the control number M9 as noted on the unit's rating plate.

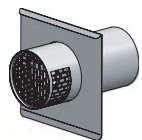

Vent Cap

Follow all requirements in the *General Venting* and *Category IV General Venting* sections for proper installation and for venting flue products to the outdoors with a sidewall termination (see pages 22 and 23).

**TABLE - 2F
FLUE VENT TERMINATION SIZES**

MODEL	CAT IV VENT SIZE	CAT IV KIT	MODEL	CAT IV VENT SIZE	CAT IV KIT
PB/FN0502-M9	4"	SVK3069	PB/FN1501-M9	6"	SVK3018
PB/FN0752-M9	5"	SVK3070	PB/FN1701-M9	7"	SVK3019
PB/FN1002-M9	6"	SVK3018	PB/FN2001-M9	8"	SVK3068
PB/FN1302-M9	8"	SVK3068	--	--	--

2 Venting

Condensing vent options: CAT IV



Horizontal direct vent installation with sidewall combustion air inlet - see page 15.

The horizontal direct vent system is installed with a Category IV flue and a separate combustion air pipe to the outdoors. The flue outlet and combustion air intake must both terminate on the same sidewall.

The connection from the appliance flue outlet to the sidewall vent cap MUST be made with listed Category IV vent materials and accessories. The installer must supply suitable vent pipe material. The horizontal direct vent must be purchased from the appliance manufacturer.

The termination point for the flue products must follow the sidewall vent termination clearance requirements on pages 29 and 30. These units can be identified by the Category IV and the control number M9 as noted on the unit's rating plate.

The horizontal direct vent kit includes the wall penetration assembly and the discharge screen assembly for the flue and a combustion air inlet cap. All required vent pipe and fittings must be purchased locally.

Follow all requirements in the General Venting and Category IV General Venting sections for proper installation and for venting flue products to the outdoors with a sidewall termination (see pages 22 and 23).

The horizontal direct vent system requires the installation of an additional pipe to supply combustion air from outdoors directly to the appliance. Follow all requirements under the *Combustion Air Inlet* section on pages 25 and 26.

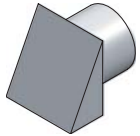
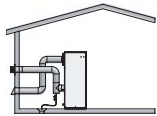

Air Inlet Cap

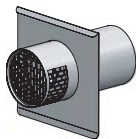

Vent Cap

TABLE - 2G SIDEWALL AIR AND VENT TERMINATION SIZES							
MODEL	CAT IV		CAT IV KIT	MODEL	CAT IV		CAT IV KIT
	AIR SIZE	VENT SIZE			AIR SIZE	VENT SIZE	
PB/FN0502-M9	5"	4"	HDK3052	PB/FN1501-M9	6"	6"	HDK3049
PB/FN0752-M9	5"	5"	HDK3053	PB/FN1701-M9	7"	7"	HDK3050
PB/FN1002-M9	6"	6"	HDK3049	PB/FN2001-M9	8"	8"	HDK3051
PB/FN1302-M9	6"	8"	HDK3054	--	--	--	--



Horizontal DirectAire installation with vertical or sidewall combustion air - page 15.

The Horizontal DirectAire vent system terminates the flue at the sidewall and air inlet at either the rooftop or a sidewall opposite the vent termination. The flue outlet and combustion air intake terminate in different pressure zones.

The connection from the appliance flue outlet to the sidewall vent cap MUST be made with listed Category IV vent materials and accessories. The installer must supply suitable vent pipe material. The Horizontal DirectAire vent cap must be purchased from the appliance manufacturer.

The termination point for the flue products must follow the sidewall vent termination clearance requirements on pages 29 and 30. These units can be identified by the Category IV and the control number M9 as noted on the unit's rating plate.

The Horizontal DirectAire vent system with a vertical air inlet requires a sidewall vent kit. The Horizontal DirectAire vent system with a sidewall air inlet requires a horizontal direct vent kit. All required vent pipe and fittings must be purchased locally.

Follow all requirements in the *General Venting* and *Category IV General Venting* sections for proper installation and for venting flue products to the outdoors with a sidewall termination (see pages 22 and 23).

The Horizontal DirectAire vent system requires the installation of an additional pipe to supply combustion air from outdoors directly to the appliance. Follow all requirements under the *Combustion Air Inlet* section on pages 24 and 25.

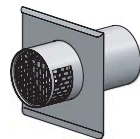
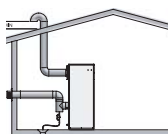

Vent Cap

TABLE - 2H SIDEWALL VENT TERMINATION SIZES							
MODEL	CAT IV		CAT IV KIT	MODEL	CAT IV		CAT IV KIT
	AIR SIZE	VENT SIZE			AIR SIZE	VENT SIZE	
PB/FN0502-M9	5"	4"	SVK3069	PB/FN1501-M9	6"	6"	SVK3018
PB/FN0752-M9	5"	5"	SVK3070	PB/FN1701-M9	7"	7"	SVK3019
PB/FN1002-M9	6"	6"	SVK3018	PB/FN2001-M9	8"	8"	SVK3068
PB/FN1302-M9	6"	8"	SVK3068	--	--	--	--

2 Venting *(continued)*

Non-Condensing Vent Options: CAT I

G

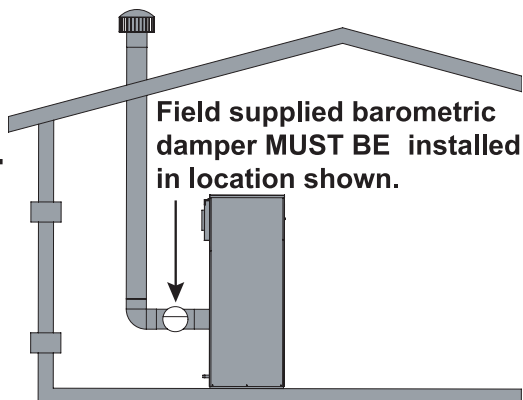

CAT I - B9

Vertical negative draft venting system - see pages 20 and 21.

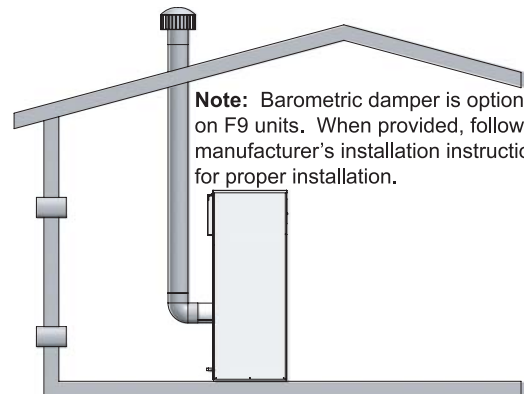

CAT I - F9

Vertical negative draft venting system - see page 20.

H

INCORRECT INSTALLATIONS

On B9 Models DO NOT install barometric damper in either of these locations.

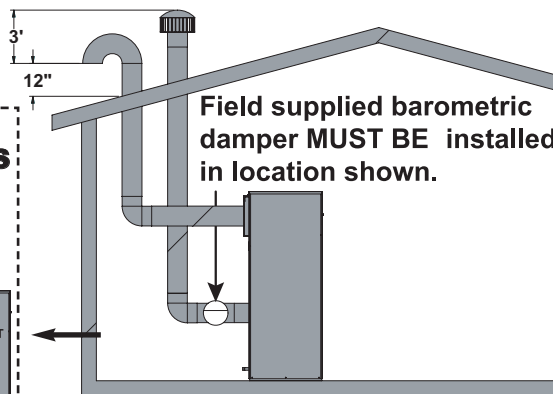
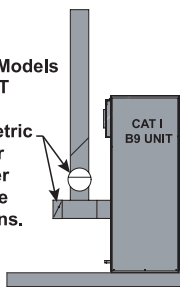

CAT I - B9

DirectAire vertical venting with vertical air inlet - see pages 20 and 21.

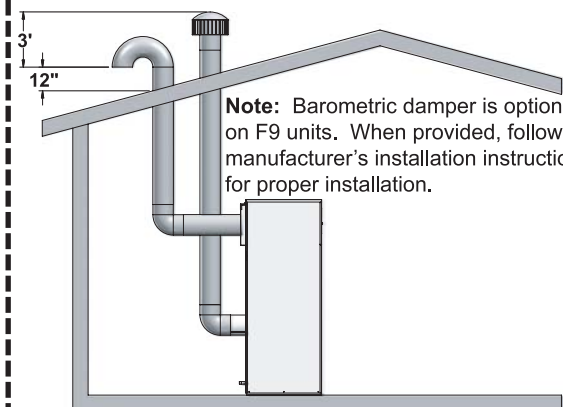

CAT I - F9

DirectAire vertical venting with vertical air inlet - see page 20.

I

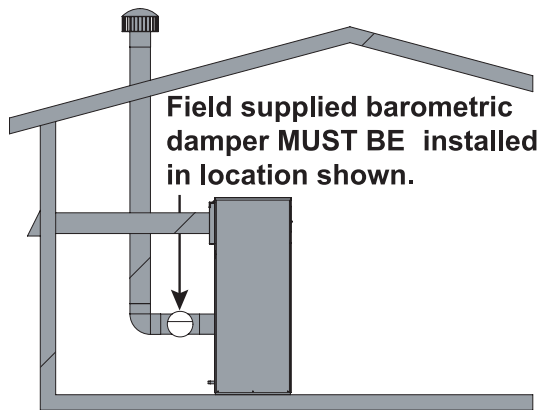

CAT I - B9

DirectAire vertical venting with sidewall inlet - see pages 20 and 21.

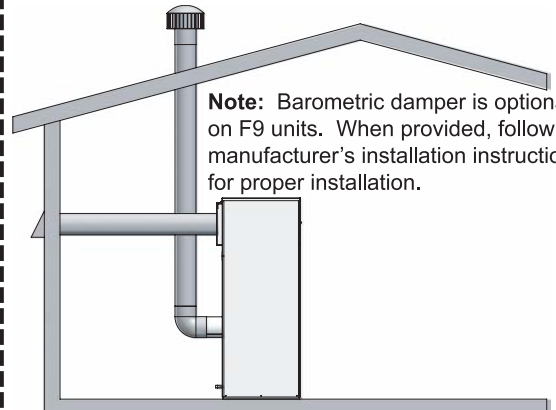

CAT I - F9

DirectAire vertical venting with sidewall inlet - see page 20.

2 Venting

Non-Condensing vent options: CAT I



CAT I

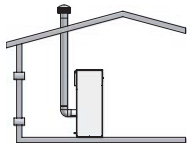

Vertical negative draft venting system - see page 19.

Units that may be vented with a Category I, Type “B” vent material operate with limited burner modulation. These units can be identified by the Category I and the control number F9 or B9 as noted on the unit’s rating plate. These are the only units that can be vented with standard double-wall vent material. See the *General Venting* and the *Negative Draft General Venting* on pages 21 and 22. The flue must terminate at the rooftop and follow the clearance requirements on pages 27 and 28. Combustion air is supplied from the equipment room. The installation of the vent must conform to the latest edition of the National Fuel Gas Code, ANSI Z223.1, in Canada, the latest edition of CGA Standard B149 Installation Code for Gas Burning Appliances and Equipment.

TABLE - 2I FIELD PROVIDED TERMINATIONS			
MODEL	VENT SIZES	MODEL	VENT SIZES
PB/FN0502-F9	7"	PB/FN1501-B9	12"
PB/FN0752-F9	9"	PB/FN1701-B9	14"
PB/FN1002-F9	10"	PB/FN2001-B9	14"
PB/FN1302-F9	12"	--	--



CAT I

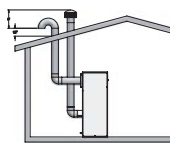

DirectAire vertical venting with vertical air inlet - see page 19.

Units that may be vented with a Category I, Type “B” vent material operate with limited burner modulation. These units can be identified by the Category I and the control number F9 or B9 as noted on the unit’s rating plate. These are the only units that can be vented with standard double-wall vent material. See the *General Venting* and the *Negative Draft General Venting* sections on pages 21 and 22. The flue must terminate at the rooftop and follow the clearance requirements on pages 27 and 28. Combustion air is supplied vertically from the rooftop. The installation of the vent must conform to the latest edition of the National Fuel Gas Code, ANSI Z223.1, in Canada, the latest edition of CGA Standard B149 Installation Code for Gas Burning Appliances and Equipment.

TABLE - 2J FIELD PROVIDED TERMINATIONS					
MODEL	AIR SIZES	VENT SIZES	MODEL	AIR SIZES	VENT SIZES
PB/FN0502-F9	5"	7"	PB/FN1501-B9	6"	12"
PB/FN0752-F9	5"	9"	PB/FN1701-B9	7"	14"
PB/FN1002-F9	6"	10"	PB/FN2001-B9	8"	14"
PB/FN1302-F9	6"	12"	--	--	--



CAT I

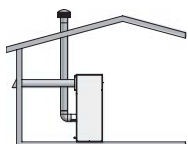

DirectAire vertical with sidewall air inlet - see page 19.

Units that may be vented with a Category I, Type “B” vent material operate with limited burner modulation. These units can be identified by the Category I and the control number F9 or B9 as noted on the unit’s rating plate. These are the only units that can be vented with standard double-wall vent material. See the *General Venting* and the *Negative Draft General Venting* sections on pages 21 and 22. The flue must terminate at the rooftop and follow the clearance requirements on pages 27 and 28. Combustion air is supplied horizontally from the outside. The installation of the vent must conform to the latest edition of the National Fuel Gas Code, ANSI Z223.1, in Canada, the latest edition of CGA Standard B149 Installation Code for Gas Burning Appliances and Equipment.

TABLE - 2K AIR INLET CAP							
MODEL	AIR SIZES	VENT SIZES	KIT NUMBER	MODEL	AIR SIZES	VENT SIZES	KIT NUMBER
PB/FN0502-F9	5"	7"	SAK3003	PB/FN1501-B9	6"	12"	SAK3004
PB/FN0752-F9	5"	9"	SAK3003	PB/FN1701-B9	7"	14"	SAK3005
PB/FN1002-F9	6"	10"	SAK3004	PB/FN2001-B9	8"	14"	SAK3006
PB/FN1302-F9	6"	12"	SAK3004	--	--	--	--

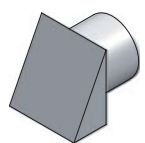

Air Inlet Cap

2 Venting *(continued)*

Common Venting CAT II:

Flues of multiple Power-fins may be combined by incorporating a vent increaser to change the Category IV appliance to a Category II vent system which can be common vented using an engineered vent system. The increaser kit must be provided by the manufacturer and the combined engineered vent system must be designed to ensure that flue products will be properly exhausted from the building at all times. **Failure to use the correct vent increaser or a properly sized vent system may result in a hazardous condition where flue gases spill into an occupied living space.** Consult a vent designer to determine the diameter of the common vent pipe required for combined vent installation. It is recommended that all vent joints and seams are sealed gastight. This vent system has specific vent material and installation requirements.

Common Venting CAT I - Venting options: G, H, & I (F9 / B9)

Common venting of multiple negative draft appliances requires that you **MUST** install a barometric damper on each unit to regulate draft. Install per the requirements of the latest edition of the National Fuel Gas Code, ANSI Z223.1 and/or CAN/CGA-B149 Installation Code.

Common Venting systems may be too large when an existing unit is removed. At the time of removal of an existing appliance, follow the steps below with each appliance remaining connected to the common venting system placed in operation, while other appliances remaining connected to the common venting system are not in operation:

- a. Seal any unused opening in the common venting system.
- b. Visually inspect the venting system for proper size and horizontal pitch and determine there is no blockage or restriction, leakage, corrosion, and other unsafe condition.
- c. Insofar as is practical, close all building doors and windows and all doors between the space in which the appliances remaining connected to the common venting system are located and other spaces of the building. Turn on clothes dryers and any other appliances not connected to the common venting system. Turn on any exhaust fans, such as range hoods and bathroom exhausts, so they will operate at maximum speed. Do not operate a summer exhaust fan. Close fireplace dampers.
- d. Place in operation the appliance being inspected. Follow the lighting (operating) instructions in this manual (see page 53). Adjust thermostat so appliance will operate continuously.
- e. Test for spillage at the draft hood / relief opening after five (5) minutes of main burner operation. Use the flame of a match or candle, or smoke from a cigarette, cigar, or pipe.
- f. After it has been determined that each appliance remaining connected to the common venting system vents properly when tested as above, return doors, windows, exhaust fans, fireplace dampers, and other gas burning appliances to their previous conditions of use.
- g. Any improper operation of the common venting system should be corrected so that the installation conforms to the latest edition of the National Fuel Gas Code, ANSI Z223.1, in Canada, the latest edition of CGA Standard B149 Installation Code for Gas Burning Appliances and Equipment.

When resizing any portion of the common venting system, the common venting system should be resized to approach the minimum size as determined using the appropriate tables in the latest edition of the National Fuel Gas Code, ANSI Z223.1, in Canada, the edition of CGA Standard B149 Installation Code for Gas Burning Appliances and Equipment.

B9 Barometric Damper CAT I - Venting options: G, H, & I (Required for B9)

Category I B9 units require a field supplied barometric damper to be installed at the rear of the unit. The damper should be installed directly after the flue collar prior to going vertical with the flue pipe as shown in the figures on page 19. The damper position indicator should be visible after its installation. The damper should be sized appropriately for the flue pipe. 1501 B9 models require a 12" damper. 1701 and 2001 B9 models require a 14" damper. When using barometric dampers, make-up air must be supplied to the room in order for them to function. Follow the manufacturer's recommendations on damper installation and operation.

Note: Barometric dampers may also be required on 502, 752, 1002, and 1302 "F9" models for use in high draft areas and are required when common venting multiple negative draft Category I appliances (see Common Venting CAT I section).

2 Venting

CAT I, II, & IV General venting information-Vent options: All Categories

Vent installation for connection to gas vents or chimneys must be in accordance with “Venting of Equipment”, of the latest edition of the National Fuel Gas Code, ANSI Z223.1, in Canada, the latest edition of CAN/CGA Standard B149 Installation Code for Gas Burning Appliances and Equipment or applicable provisions of the local building codes.

All venting applications where combustion air is drawn from the equipment room must have adequate combustion and ventilation air supplied to the equipment room in accordance with the latest edition of CAN/CGA Standard B149 Installation Code for Gas Burning Appliances and Equipment or applicable provisions of the local building codes.

The distance of the vent terminal from adjacent buildings, windows that open and building openings MUST comply with the minimum clearances stated in this manual and the latest edition of the National Fuel Gas Code, ANSI Z223.1, in Canada, the latest edition of CAN/CGA Standard B149 Installation Code for Gas Burning Appliances and Equipment.

The vent connection is made directly to the flue outlet opening on the rear of the unit. The connection from the appliance vent to the stack must be made as direct as possible with no reduction in diameter.

NOTICE

Examine the venting system at least once a year. Check all joints and vent pipe connections for tightness. Also check for corrosion or deterioration. Immediately correct any problems observed in the venting system.

CAT IV Specific venting information: Vent Options A, B, C, D, E, & F

A Category IV venting system operates with a positive pressure in the vent. This positive pressure is generated by the internal combustion air blower which operates the combustion process and also exhausts the flue products from the building. The Category IV flue from this appliance cannot be combined with the vent from any other appliance. **The Category IV flue from this appliance must be a dedicated stack, there is one exception however. The Category IV flues from multiple Power-fin appliances may only be combined when using an engineered vent system incorporating an induced draft fan to ensure that flue products will be properly exhausted from the building at all times. Failure to use a properly sized induced draft fan on a combined Category IV vent installation may result in a hazardous condition where flue gases spill into an occupied living space.** Consult the induced draft fan manufacturer to size the induced draft fan and to determine the diameter of the common vent pipe required for a combined vent installation. The flue from this Category IV appliance must have all vent joints and seams sealed gastight. A Category IV vent system has specific vent material and installation requirements.

The flue products in the vent system may be cooled below their dew point and form condensate in the flue. The flue materials used for a Category IV vent must be resistant to any corrosive damage from flue gas condensate. The flue from a Category IV vent system must have a condensate drain with provisions to properly collect and dispose of any condensate that may occur in the venting system.

The connection from the appliance vent to the stack or vent termination outside the building must be made with listed Category IV vent material and must be as direct as possible. The Category IV vent and accessories such as firestop spacers, thimbles, caps, etc., must be installed in accordance with the vent manufacturer’s instructions. The vent connector and firestop must provide correct spacing to combustible surfaces and seal to the vent connector on the upper and lower sides of each floor or ceiling through which the vent connector passes.

Any vent materials specified must be listed by a nationally recognized test agency for use as a Category IV vent material.

The venting system must be planned so as to avoid possible contact with concealed plumbing or electrical wiring inside walls, floors, or ceilings. Locate the appliance as close as possible to a chimney or gas vent.

Horizontal portions of the venting system shall be supported to prevent sagging. Horizontal runs should slope upwards not less than a 1/4 inch per foot from the drain tee installed in the flue to the vertical portion of the flue or to the vent terminal on sidewall venting installations. This ensures proper removal of any condensate that may form in the flue. Follow the installation instructions from the vent material manufacturer.

2 Venting *(continued)*

CAT IV Specific venting information *(continued)*: Vent options A, B, C, D, E, & F

Do not use an existing chimney as a raceway if another appliance or fireplace is vented through the chimney. The weight of the venting system must not rest on the unit. Adequate support of the venting system must be provided in compliance with local codes and other applicable codes. All connections should be secured and sealed per the vent manufacturer's specifications.

Vent connectors serving appliances vented by natural draft shall not be connected to any portion of the Category IV positive pressure vent system used by this appliance. Connection of a negative draft flue into the positive pressure stack from this appliance may cause flue products to be discharged into an occupied living space causing serious health injury.

When a Category IV vent system is disconnected for any reason, the flue must be reassembled and resealed according to the vent manufacturer's instructions.

The flue may terminate either vertically at the rooftop or horizontally on a sidewall. Refer to the specific vent termination sections for information about recommended vent termination location and clearances.

Length of flue pipe

The installed length of the Category IV flue from the appliance to the point of termination, outside of the building, must not exceed a maximum of 50 equivalent feet (15.2m) in length. Subtract 5 feet (1.5m) of equivalent length for each 90° elbow installed in the vent. Subtract 2 1/2 feet (0.7m) of equivalent length for each 45° elbow installed in the vent.

CAT II/IV Drain Tee Requirements: Vent options A, B, C, D, E, & F

Drain tee installation

A drain tee must be installed in the Category II & IV vent pipe to collect and dispose of any condensate that may occur in the vent system. The drain tee should be installed at the point where the flue turns vertical for a rooftop termination or as one of the first fittings in a horizontal flue connector that will terminate on a sidewall. Ensure that horizontal portions of the vent are properly sloped to allow condensate to be evacuated at the drain tee. Plastic drain tubing, sized per the vent manufacturer's instructions, shall be provided as a drain line from the tee. The drain tubing must have a trap provided by a 10" (25.4cm) diameter circular trap loop in the drain tubing. Prime the trap loop by pouring a small quantity of water into the drain hose before assembly to the vent. Secure the trap loop in position with nylon wire ties. Use caution not to collapse or restrict the condensate neutralization system or a suitable drain for disposal of condensate that may occur in the Category IV vent system. Ensure that the drain from the condensate tee is not exposed to freezing temperatures. See Section 7, *Startup - Freeze Protection* for more information.

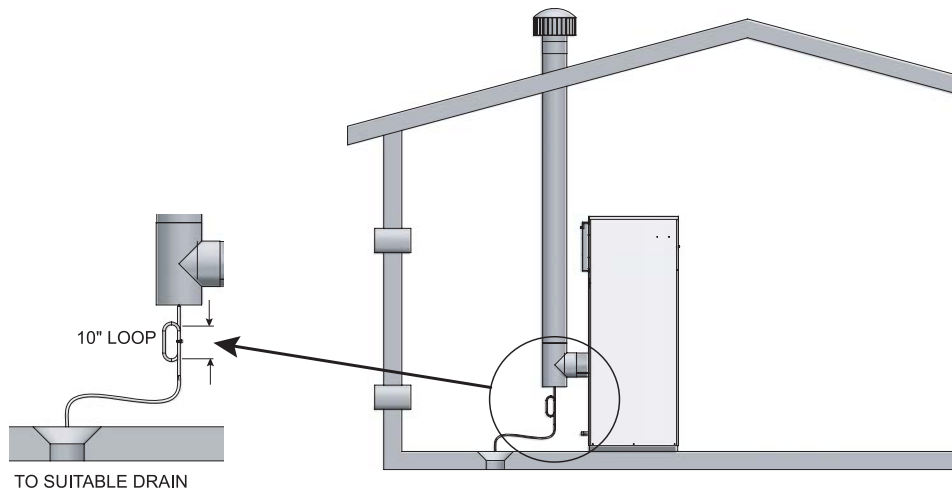

Figure 2-3_Drain Tee Installation

CAT I Specific venting information:

Follow all requirements set forth in the latest edition of the National Fuel Gas Code, ANSI Z223.1, in Canada, the latest edition of the CAN/CGA Standard B149 Installation Code for Gas Burning Appliances and Equipment or applicable provisions of the local building codes.

2 Venting

Vertical Air Inlet: Vent options B, F, & H

Vertical combustion air inlet

The air inlet cap for the vertical rooftop air inlet is assembled from components purchased locally. The air inlet cap consists of two 90° elbows installed at the point of termination for the air inlet pipe. The first 90° elbow is installed on the rooftop at the highest vertical point of the air inlet pipe and turned horizontal, the second 90° elbow is installed on the horizontal outlet of the first elbow and turned down.

A 90° elbow and a 90° street elbow may be used to make this assembly. If a straight piece of pipe is used between the two elbows, it should not exceed 6 inches (152mm) in length. The termination elbow on the air inlet must be located a minimum of 12 inches (0.30m) above the roof or above normal levels of snow accumulation.

Location of a vertical air inlet cap

Incorrect installation and/or location of the air inlet cap can allow the discharge of flue products to be drawn into the combustion process on the heater. This can result in incomplete combustion and potentially hazardous levels of carbon monoxide in the flue products. This will cause operational problems with the heater and possible spillage of flue products that can cause personal injury, death, or property damage.

The point of termination for the combustion air inlet cap MUST be at least 3 feet (0.91m) below the point of flue gas termination (vent cap) if it is located within a 10 foot (3.05m) radius of the flue outlet. Use care to ensure that the 90° elbow assembly is properly installed on the air inlet pipe.

The combustion air inlet cap must not be installed closer than 10 feet (3.05m) from an inside corner of an L-shaped structure.

The termination point of the combustion air inlet cap must be installed at least one foot (0.30m) above the rooftop and above normal snow levels.

The combustion air cap assembly used MUST adequately protect the combustion air inlet from wind and weather.

Combustion air supplied from outdoors must be free of contaminants (see *Combustion and Ventilation Air*, page 10). To prevent recirculation of flue products into the combustion air inlet, follow all instructions in this section.

The combustion air inlet caps for multiple appliance installations must maintain the minimum 3 foot (0.91m) clearance below the closest vertical flue outlet if within 10 feet (3.05m).

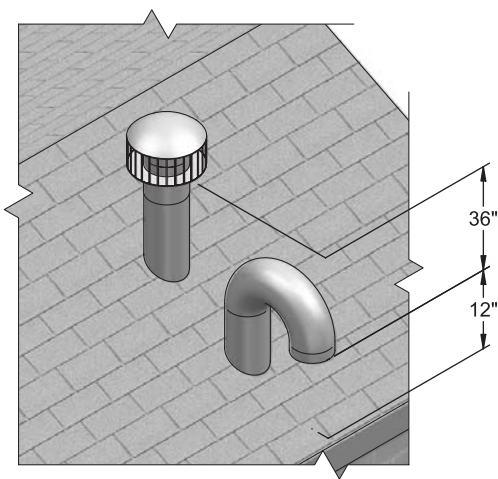

Figure 2-4_Vertical Air Inlet Clearances

2 Venting *(continued)*

Horizontal Air Inlet: Vent options C, E, F, & I

Sidewall combustion air inlet

The sidewall termination caps for both the flue products and combustion air must be purchased from the appliance manufacturer.

The part numbers for the required sidewall termination kit are listed under each designated table. Each kit includes both the special combustion air inlet cap and the sidewall flue cap for installation on an exterior sidewall. The sidewall air inlet cap supplied in the kit is sized to provide combustion air for a single appliance only.

Location of a sidewall air inlet cap

Incorrect installation and/or location of the air inlet cap can allow the discharge of flue products to be drawn into the combustion process on the heater. This can result in incomplete combustion and potentially hazardous levels of carbon monoxide in the flue products. This will cause operational problems with the heater and possible spillage of flue products that can cause personal injury, death, or property damage.

The termination point of the sidewall air inlet must be installed a minimum of 12 inches (0.30m) above ground level and above normal levels of snow accumulation.

The point of termination for the sidewall combustion air inlet cap **MUST** be located a minimum of 3 feet (0.91m) horizontally and 12 inches (0.30m) below the point of flue gas termination (vent cap) if it is located within a 10 foot (3.05m) radius of the flue outlet.

The combustion air inlet caps for multiple appliance installations must maintain the same minimum clearance from the closest vent cap installed within a 10 foot radius of the point of flue gas termination as specified in single appliance installations.

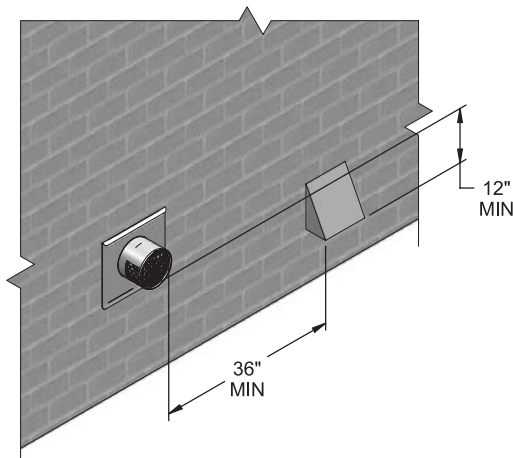

Figure 2-5_Horizontal Air Inlet Clearances

The combustion air inlet cap must not be installed closer than 10 feet (3.05m) from an inside corner of an L-shaped structure.

The combustion air cap assembly used **MUST** adequately protect the combustion air inlet from wind and weather.

Combustion air supplied from outdoors must be free of contaminants (see *Combustion and Ventilation Air*, page 10). To prevent recirculation of flue products into the combustion air inlet, follow all instructions in this section.

Multiple horizontal or vertical direct vent installations

The combustion air inlet caps for multiple appliance installations must maintain the same minimum clearance from the closest vent cap installed within a 10 foot radius of the point of flue gas termination as specified in single appliance installations. Multiple flue outlet caps may be installed side by side and multiple air inlet caps may be installed side by side, but the minimum clearance of a 3 feet (0.91m) horizontal radius and 12 inches (0.30m) below the closest flue outlet to the air inlet cap must be maintained. All clearance and installation requirements in this section and the applicable portions of the *Category IV General Venting* section must be maintained on multiple appliance installations.

2 Venting

Length of air inlet pipe for both vertical and horizontal -Vent options: All Categories

The maximum installed length of the air inlet pipe from the appliance to the air inlet cap is 50 equivalent feet (15.2m) in length. Subtract 5 feet (1.52m) of equivalent length for each 90° elbow installed in the air inlet pipe. Subtract 2 1/2 feet (0.7m) of equivalent length for each 45° elbow installed in the air inlet pipe.

Air inlet pipe materials:

The air inlet pipe(s) must be sealed. Choose acceptable combustion air inlet pipe materials from the following list:

PVC, CPVC or ABS

Dryer Vent or Sealed Flexible Duct (not recommended for rooftop air inlet)

Galvanized steel vent pipe with joints and seams sealed as specified in this section.

Type “B” double-wall vent with joints and seams sealed as specified in this section.

*Plastic pipe may require an adapter (not provided) to transition between the air inlet connection on the appliance and the plastic air inlet pipe.

⚠ WARNING

Using vent or air intake materials other than those specified, failure to properly seal all seams and joints or failure to follow vent pipe manufacturer's instructions can result in personal injury, death or property damage. Mixing of venting materials will void the warranty and certification of the appliance.

NOTICE

The use of double-wall vent or insulated material for the combustion air inlet pipe is recommended in cold climates to prevent the condensation of airborne moisture in the incoming combustion air.

Sealing of Type “B” double-wall vent material or galvanized vent pipe material used for air inlet piping on a sidewall or vertical rooftop Combustion Air Supply System:

- Seal all joints and seams of the air inlet pipe using either Aluminum Foil Duct Tape meeting UL Standard 723 or 181A-P or a high quality UL Listed silicone sealant such as those manufactured by Dow Corning or General Electric.
- Do not install seams of vent pipe on the bottom of horizontal runs.
- Secure all joints with a minimum of three sheet metal screws or pop rivets. Apply Aluminum Foil Duct Tape or silicone sealant to all screws or rivets installed in the vent pipe.
- Ensure that the air inlet pipes are properly supported.

The PVC, CPVC, or ABS air inlet pipe should be cleaned and sealed with the pipe manufacturer's recommended solvents and standard commercial pipe cement for the material used. The PVC, CPVC, ABS, Dryer Vent or Flex Duct air inlet pipe should use a silicone sealant to ensure a proper seal at the appliance connection and the air inlet cap connection. Dryer vent or flex duct should use a screw type clamp to seal the vent to the appliance air inlet and the air inlet cap. Proper sealing of the air inlet pipe ensures that combustion air will be free of contaminants and supplied in proper volume.

When a sidewall or vertical rooftop combustion air supply system is disconnected for any reason, the air inlet pipe must be resealed to ensure that combustion air will be free of contaminants and supplied in proper volume.

⚠ DANGER

Failure to properly seal all joints and seams as required in the air inlet piping may result in flue gas recirculation, spillage of flue products and carbon monoxide emissions causing severe personal injury or death.

Combined combustion air inlet points

The air inlet pipes from multiple appliances can be combined to a single common connection if the common air inlet pipe has a cross sectional area equal to or larger than the total area of all air inlet pipes connected to the common air inlet pipe. [Example: two 8" (20.3cm) air inlet pipes (50.3 in²(324.5cm²) area each) have a total area of 100.6 in² (645.2cm²) requires a 12 inch (30.5cm) (113.1in²area) (729.7cm²) common air inlet pipe.] The air inlet point for multiple boiler air inlets must be provided with an exterior opening which has a free area equal to or greater than the total area of all air inlet pipes connected to the common air inlet. This exterior opening for combustion air must connect directly to the outdoors. The total length of the combined air inlet pipe must not exceed a maximum of 50 equivalent feet (15.2m). You must deduct the restriction in area provided by any screens, grills, or louvers installed in the common air inlet point. These are common on the sidewall air inlet openings and some rooftop terminations. Screens, grills, or louvers installed in the common air inlet can reduce the free area of the opening from 25% to 75% based on the materials used.

2 Venting *(continued)*

Vertical Vent Termination Clearances - Venting options: A, B, C, G, H & I

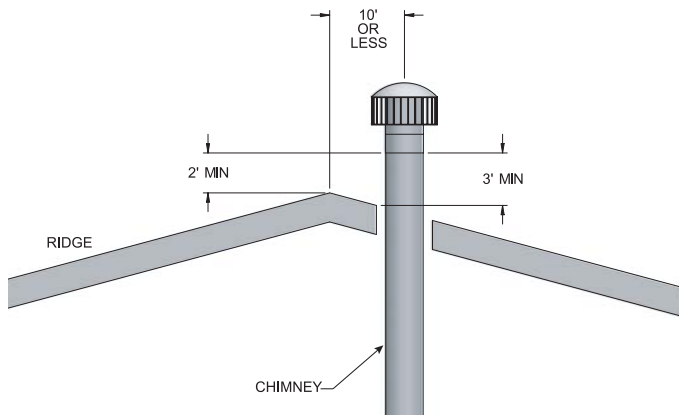

Figure 2-6_Vent Termination from Peaked Roof - 10 ft. or Less From Ridge

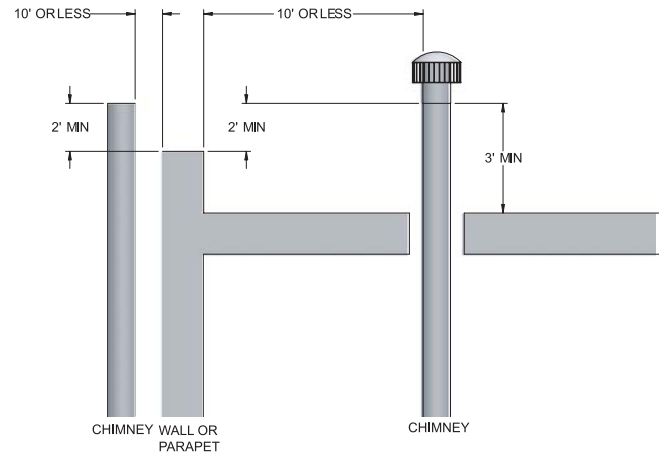

Figure 2-8_Vent Termination from Flat Roof - 10 ft. or Less From Parapet Wall

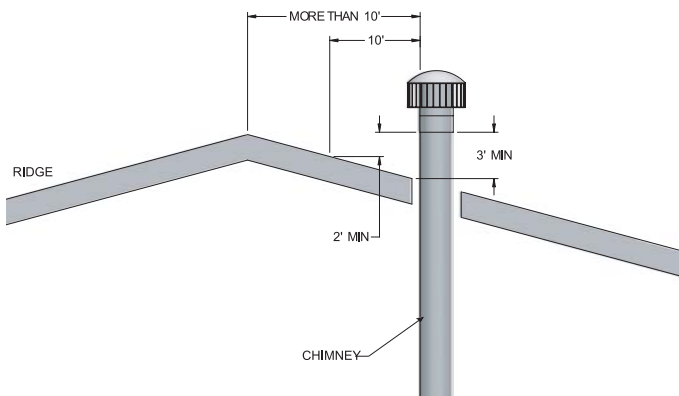

Figure 2-7_Vent Termination from Peaked Roof - 10 ft. or More From Ridge

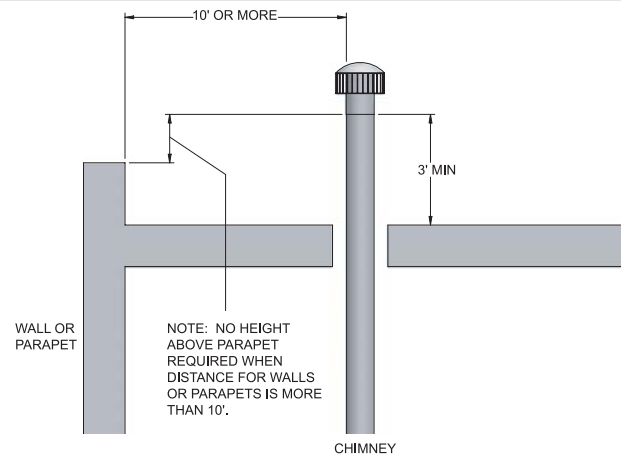

Figure 2-9_Vent Termination from Flat Roof - 10 ft. or More From Parapet Wall

The vent terminal should be vertical and exhaust outside the building at least 2 feet (0.61m) above the highest point of the roof within a 10 foot (3.05m) radius of the termination.

The vertical termination must be a minimum of 3 feet (0.91m) above the point of exit.

A vertical termination less than 10 feet (3.05m) from a parapet wall must be a minimum of 2 feet (0.61m) higher than the parapet wall.

The vent cap should have a minimum clearance of 4 feet (1.22m) horizontally from and in no case above or below, unless a 4 foot (1.22m) horizontal distance is maintained from electric meters, gas meters, regulators, and relief equipment.

The venting system shall terminate at least 3 feet (0.9m) above any forced air inlet within 10 feet (3.05m).

The venting system shall terminate at least 4 feet (1.2m) below, 4 feet (1.2m) horizontally from, or 1 foot (30cm) above any door, window, or gravity air inlet into any building.

Do not terminate the vent in a window well, stairwell, alcove, courtyard, or other recessed area. The vent cannot terminate below grade. The bottom of the vent terminal shall be located at least 12 inches (30cm) above the roof or above normal snow levels.

To avoid a blocked flue condition, keep the vent cap clear of snow, ice, leaves, debris, etc.

2 Venting

Vertical Vent Termination Clearances - Venting options: A, B, C, G, H & I

Flue gases from this appliance may contain large amounts of water vapor that will form a white plume in winter. Plume could obstruct window view.

Flue gas condensate can freeze on exterior surfaces or on the vent cap. Frozen condensate on the vent cap can result in a blocked flue condition. Flue gas condensate can cause discoloration of exterior building surfaces. Adjacent brick or masonry surfaces should be protected with a rust resistant sheet metal plate.

The manufacturer shall NOT be held liable for any personal injury or property damage due to ice formation or dislodging of ice from the vent system or vent termination.

Masonry chimney installations

A standard masonry chimney must NOT be used to vent the products of combustion from the flue of a Category IV, positive pressure appliance. If a masonry chimney is to be used, the chimney MUST use a sealed, metallic, corrosion resistant liner system to vent flue products from this high efficiency appliance. Sealed, metallic, corrosion resistant liner systems (single-wall, double-wall, flexible or rigid metallic lines) must be rated for use with a high efficiency, Category IV, positive pressure vent system. Corrosion resistant chimney liner systems are typically made from a high grade of corrosion resistant stainless steel such as AL29-4C. The corrosion resistant liner must be properly sized and fully sealed throughout the entire length if the flue is contained within the masonry chimney. Both the top and the bottom of the masonry chimney must be capped and sealed to provide a dead air space around the sealed corrosion resistant metallic liner. Consult with local code officials to determine code requirements or the advisability of using a masonry chimney with a sealed corrosion resistant liner system.

⚠ CAUTION

Venting of a high efficiency Category IV appliance into a masonry chimney without a sealed stainless steel liner can result in operational and safety problems. Any breaks, leaks, or damage to the masonry flue/tile will allow spillage of the positive pressure flue products from the chimney. These flue products can easily escape into an occupied living space causing a health hazard. If there is any doubt about the condition of a masonry chimney, or its acceptability for use after insertion of a corrosion resistant liner system, consult with local code officials.

2 Venting *(continued)*

Sidewall Vent Termination Clearances - Venting options: D, E, & F

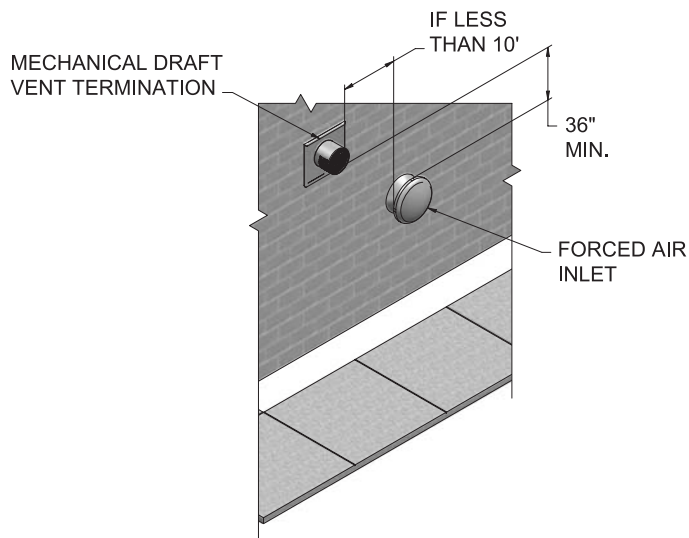

Figure 2-10_Vent to Forced Air Inlet

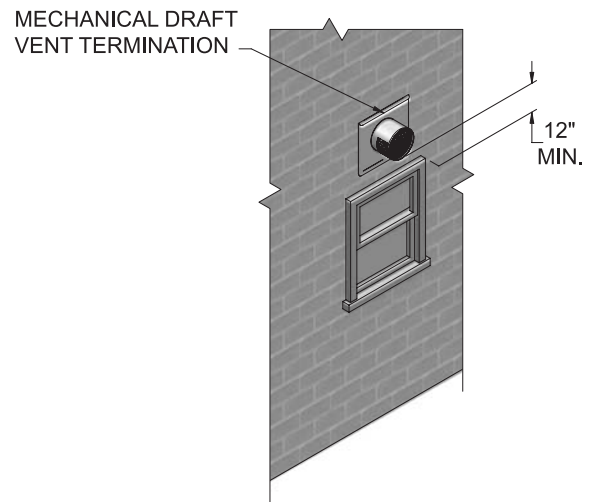

Figure 2-12_Vent Above Window

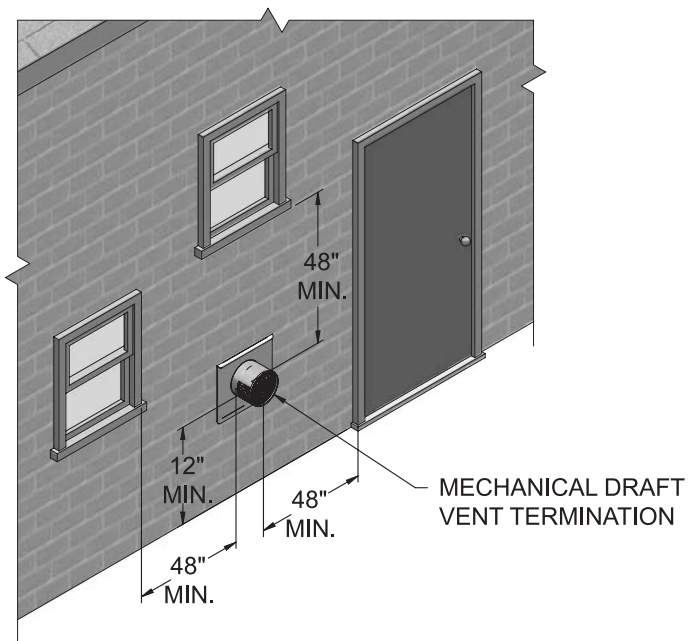

Figure 2-11_Vent to Doors and Windows

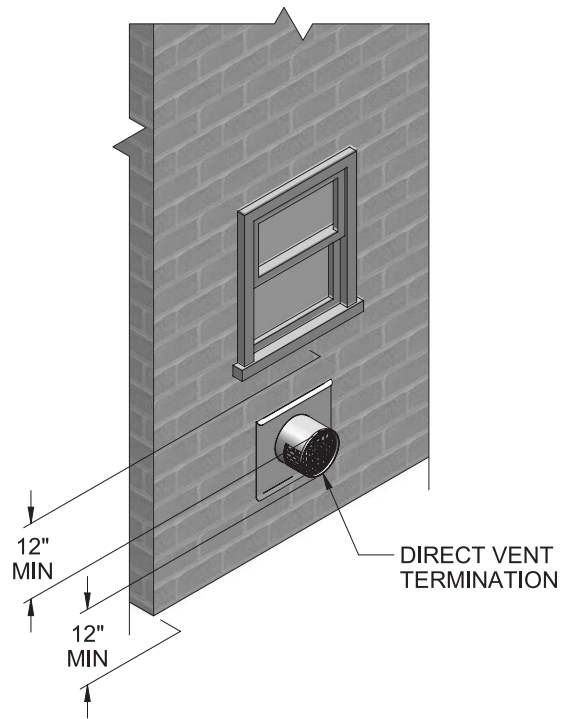

Figure 2-13_Direct Vent Clearance

2 Venting

Location of a sidewall vent termination - Venting options: D, E, & F

The vent cap shall terminate at least 3 feet (0.91m) above any forced air inlet within 10 feet (3.05m).

The vent shall terminate at least 4 feet (1.22m) below, 4 feet (1.22m) horizontally from or 1 foot (0.30m) above and 2 feet (0.60m) horizontally from any door, window, or gravity air inlet to the building.

The sidewall vent termination must be at least 8 feet (2.4m) horizontally from any combustion air intake located above the sidewall termination cap.

Do not terminate the vent in a window well, stairwell, alcove, courtyard, or other recessed area. The vent cap cannot terminate below grade.

The vent shall not terminate directly above a public walkway due to the normal formation of water vapor in the combustion process. Horizontal terminations must not be located over areas of pedestrian or vehicular traffic.

The vent system shall terminate at least 1 foot (0.30m) above grade, above normal snow levels and at least 7 feet (2.13m) above grade when located adjacent to public walkways.

The vent terminal shall not be installed closer than 3 feet (0.91m) from an inside corner of an L-shaped structure.

The vent cap should have a minimum clearance of 4 feet (1.22m) horizontally from and in no case above or below, unless a 4 foot (1.22m) horizontal distance is maintained from electric meters, gas meters, regulators, and relief equipment.

Flue gas condensate can freeze on exterior walls or on the vent cap. Frozen condensate on the vent cap can result in a blocked flue condition. Some discoloration to exterior building surfaces can be expected. Adjacent brick or masonry surfaces should be protected with a rust resistant sheet metal plate.

The sidewall vent system **MUST** use the sidewall vent cap kit provided by the appliance manufacturer for installation on a sidewall termination.

The sidewall vent cap **MUST** be purchased as a kit from the appliance manufacturer to ensure proper operation. Locally purchased or fabricated sidewall vent caps should not be used.

3 Gas connections

Gas supply

Verify that the appliance is supplied with the type of gas specified on the rating plate. This appliance is configured for operation up to 4000 feet altitude. Consult factory for installations above 4000 feet elevation.

Inlet gas pressure: Measured at the inlet pressure tap on the appliance gas manifold. The pressure tap is located upstream of the redundant gas valve and downstream of the field installed gas cock.

**TABLE 3A
INLET GAS PRESSURE**

MODEL	CODE	NATURAL		LP	
		Max. w.c.	Min. w.c.	Max. w.c.	Min. w.c.
502 - 1302	F9	10.5	4.2	13.0	11.0
502 - 1302	M9	14.0	4.0	13.0	11.0
1501 - 2001	B9	14.0	4.0	14.0	8.0
1501 - 2001	M9	14.0	4.0	14.0	8.0

Maximum inlet gas pressure must not exceed the value specified. Minimum value listed is for the purposes of input adjustment.

Gas pressure test

1. The appliance must be disconnected from the gas supply piping system during any pressure testing of that system at a test pressure in excess of 1/2 PSIG (3.5 kPa).
2. The appliance must be isolated from the gas supply piping system by closing a manual shutoff valve during any pressure testing of the gas supply piping system at test pressures equal to or less than 1/2 PSIG (3.5 kPa).
3. The appliance and its gas connection must be leak tested before placing it in operation.

Checking manifold gas pressure

Reference the Power-fin Service Manual for information regarding manifold gas pressure.

Gas connection

Safe operation of the appliance requires properly sized gas supply piping. See gas line sizing data:

1. Gas pipe size may be larger than appliance connection.
2. Installation of a union at the appliance gas line connection is required for ease of service and removal of the gas train.
3. If an additional manual shutoff valve is required by local codes, install the valve on the outside at the gas supply to the appliance as shown in FIG. 3-1.
4. A sediment trap (drip leg) **MUST** be provided in the inlet of the gas connection to the appliance, see FIG. 3-1.
5. Optional gas controls may require routing of bleeds and vents to the atmosphere, outside the building when required by local codes.

**TABLE - 3B
FITTINGS TO EQUIVALENT STRAIGHT PIPE**

Diameter Pipe (inches)	1 1/2	2	3	4	5
Equivalent length of Straight Pipe (feet)	4	5	10	14	20

NOTICE

If an inline high gas pressure regulator is used, it **MUST BE** of the lockup type and be located a minimum of 10 feet from the appliance. Failure to do so may result in insufficient gas volume supplied to the appliance.

3 Gas connections

TABLE - 3C
GAS PIPING SIZE CHART

Nominal Iron Pipe Size Inches	Length of Pipe in Straight Feet														Maximum Capacity of Pipe in Thousands of Btu/hr per hour for gas pressures of 14 Inches Water Column (0.5 PSIG) or less and a pressure drop of 0.5 Inch Water Column (Based on NAT GAS, 1025 Btu/hr per Cubic Foot of Gas and 0.60 Specific Gravity)
	10	20	30	40	50	60	70	80	90	100	125	150	175	200	
3/4	369	256	205	174	155	141	128	121	113	106	95	86	79	74	
1	697	477	384	328	292	267	246	256	210	200	179	164	149	138	
1 1/4	1,400	974	789	677	595	543	502	472	441	410	369	333	308	287	
1 1/2	2,150	1,500	1,210	1,020	923	830	769	707	666	636	564	513	472	441	
2	4,100	2,820	2,260	1,950	1,720	1,560	1,440	1,330	1,250	1,180	1,100	974	871	820	
2 1/2	6,460	4,460	3,610	3,100	2,720	2,460	2,310	2,100	2,000	1,900	1,700	1,540	1,400	1,300	
3	11,200	7,900	6,400	5,400	4,870	4,410	4,000	3,800	3,540	3,300	3,000	2,720	2,500	2,340	
4	23,500	16,100	13,100	11,100	10,000	9,000	8,300	7,690	7,380	6,870	6,150	5,640	5,130	4,720	

Gas piping

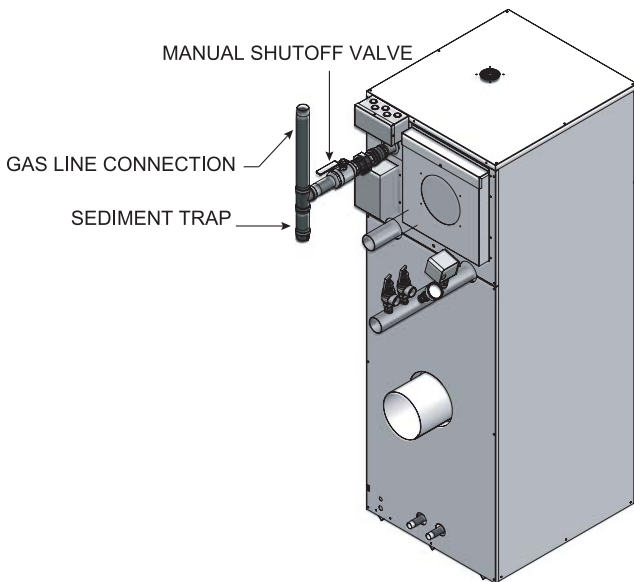

Figure 3-1_Gas Line Connection with Sediment Trap (Drip Leg) and Manual Main Gas Shutoff Valve

All gas connections must be made with pipe joint compound resistant to the action of liquefied petroleum and natural gas. All piping must comply with local codes and ordinances. Tubing installations must comply with approved standards and practices.

Install piping to control

1. The gas line should be a separate line direct from the meter unless the existing gas line is of sufficient capacity. Verify pipe size with your gas supplier.
2. Use new, properly threaded black iron pipe free from chips. If tubing is used, make sure the ends are square, deburred and clean. All tubing bends must be smooth and without deformation. Avoid flexible gas connections. Internal diameter of flexible gas lines may not provide appliance with proper volume of gas.
3. Run pipe or tubing to the unit's gas inlet. If tubing is used, obtain a tube to pipe coupling in order to connect the tubing to the unit's gas inlet.
4. Install a sediment trap in the supply line to the unit's gas inlet (see FIG. 3-1).
5. Remove seal over gas inlet to the appliance.
6. Apply a moderate amount of good quality pipe compound (DO NOT use Teflon tape) to pipe only, leaving two end threads bare.
7. Connect gas pipe to inlet of appliance. Use a wrench to support the gas manifold on the appliance.
8. For LP gas, consult your LP gas supplier for expert installation.

3 Gas connections *(continued)*

Checking gas supply pressure

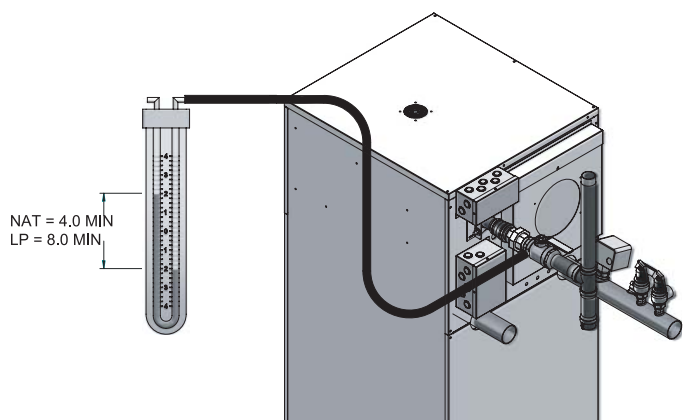

Figure 3-2_Gas Supply Pressure Measurement

1. Turn the main power switch to the “OFF” position.
2. Shut off the gas supply at the manual gas cock in the gas piping to the appliance. If fuel supply is LP gas, shut off gas supply at the tank.
3. Remove the 1/8" hex plug from the gas pressure test port located on the manual shutoff valve at the rear of the appliance. Install a fitting in the inlet pressure tapping suitable to connect to a manometer or magnahelic gauge. Range of scale should be 14 inches water column or greater to check inlet pressure.
4. Turn on gas supply at the field installed manual gas cock, turn on LP gas at tank if required.
5. Turn the power switch to the “ON” position.
6. Adjust the temperature set point on the display to call for heat.
7. Observe the gas supply pressure as the burner fires at 100% of rated input. Percent of burner input will be shown on the display of the SMART SYSTEM control module.
8. Ensure inlet pressure is within specified range. Minimum and maximum gas supply pressures are specified in the *Gas Supply* section of this manual.
9. If gas pressure is out of range, contact the gas utility, gas supplier, qualified installer or service agency to determine necessary steps to provide proper gas pressure to the control.
10. If gas supply pressure is within normal range, proceed to remove gas manometer and replace pressure tap fittings in the gas piping to the appliance.
11. Turn the power switch to the “OFF” position.
12. Shut off gas supply at the manual gas cock in the gas piping to the appliance. If fuel supply is LP gas, shut off gas supply at the tank.
13. Remove the manometer and related fittings from the gas pressure test port at the inlet gas supply connection to the appliance. Replace the 1/8" plug in the gas pressure test port and tighten.
14. Turn on the gas supply at the manual valve, turn on LP gas at the tank if required.
15. Turn the power switch to the “ON” position.
16. Adjust the temperature set point on the display of the SMART SYSTEM control module to the desired water temperature so the appliance will call for heat.
17. Check burner performance by cycling the system while you observe burner response. The burner should ignite promptly. Flame pattern should be stable, see “*Maintenance - Normal Flame Pattern*” in the Power-fin Service Manual. Turn system off and allow burner to cool, then cycle burner again to ensure proper ignition and flame characteristics.

NOTICE

If a pressure drop of more than 2" w.c. occurs between Standby (Static) Mode and Operating (Dynamic) Mode, a gas volume problem exists. Contact the gas utility, gas supplier, qualified installer, or service agency to determine the necessary steps to provide the proper gas volume to the appliance.

3 Gas connections

Gas train

NOTICE

The gas train and controls assembly provided on this unit have been tested under the applicable American National Standard to meet minimum safety and performance criteria such as safe lighting, combustion, and safety shutdown operation.

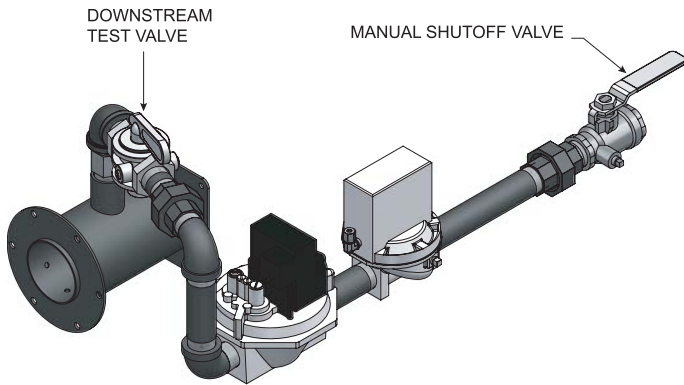

Figure 3-3_Gas Train Assembly F9

Venting of F9 gas train and optional pressure switches

The diaphragm type gas valve and optional gas pressure switches are provided with threaded termination points to be vented to the atmosphere, outside the building, if required by local codes. The gas pressure regulation function is provided by the ratio gas valve which does not require installation of a vent line. The diaphragm gas valve and optional gas pressure switches are installed in the upper chamber of the appliance. Threaded vent line connections from components requiring an external vent line are provided on the component. These vent line connection points may be accessed by removing the top jacket panels. Local codes may require the routing of these bleeds and vents to the atmosphere outside the building. Proper routing of vent lines to the atmosphere from the factory supplied termination points is the responsibility of the installing contractor.

M9 gas train

The combination gas valve on this appliance uses line (120 VAC) voltage for operation. The valve contains the safety shutoff and operating valves required on boilers and water heaters. The valve uses the negative pressure signal generated by the venturi to modulate the amount of gas, so that the proper mixture of air and gas is delivered to the burner throughout the full range of burner operation.

There are no serviceable parts on the combination gas valve.

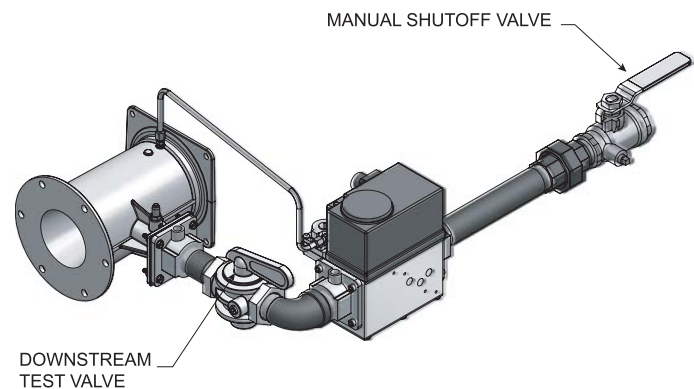

Figure 3-4_Gas Train Assembly M9/B9

4 Water connections

Inlet and outlet connections

For ease of service, install unions on the inlet and outlet of the appliance. The connection to the appliance marked “Water Inlet” on the header should be used for return from the system. The connection on the header marked “Hot Water Outlet” is to be connected to the supply side of the system. Minimum water pipe connections to this appliance are 2 1/2 inches (63.5mm) pipe. See the piping requirements in the heating boiler or water heater section of this manual for multiple appliance installations.

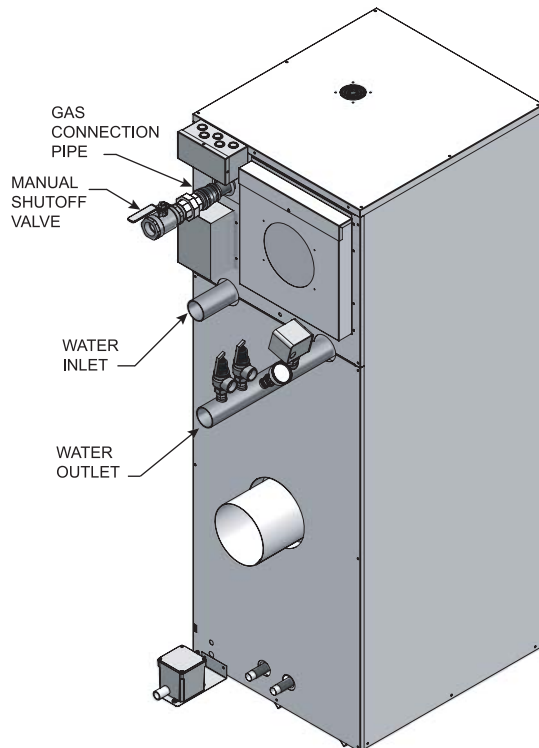

Figure 4-1_Water Connections

Heat exchanger

This appliance uses a finned copper tube heat exchanger to maximize the heat transfer process. The heat exchanger is mounted in the inner jacket on the front side of the appliance. The heat exchanger is composed of two circular, glass lined, and cast iron headers with either 20 or 24 (depending on the model) vertical finned copper tubes (FIG. 4-2). A series of “V” shaped baffles are installed between the individual tubes to control the movement of the flue products over the finned copper surface and increase heat transfer. Water enters the heat exchanger and makes four passes over the area exposed to direct heat from the burner. A circulating pump **MUST** be installed to ensure proper water flow over the heat transfer surfaces during burner operation. Water temperatures in the heat exchanger are determined by water flow.

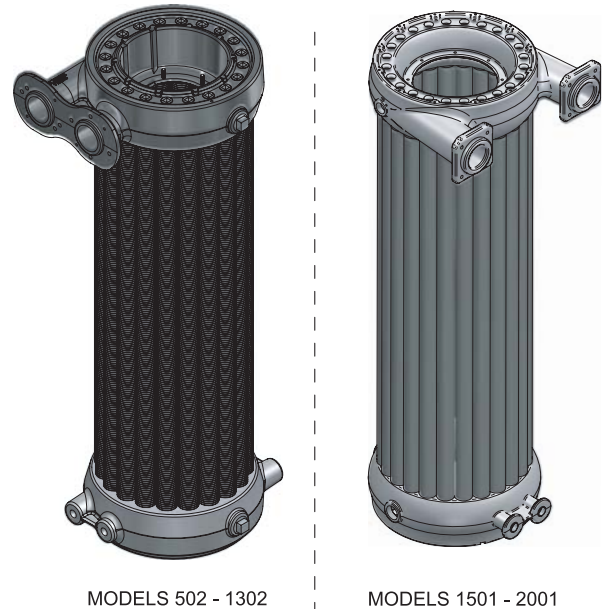

Figure 4-2_Heat Exchanger(s)

Initial set-up of maximum water flow

On initial start-up of the Power-fin, the maximum water flow to the heat exchanger must be checked and manually limited with a valve or bypass before normal operation begins.

Minimum water temperatures

A minimum return water temperature of 140°F (60°C) has been established to control condensate formation based on the Btu/hr output at rated burner input. Maintaining inlet water temperatures to the appliance equal to or higher than the specified minimum temperature ensures proper operation of the appliance and prevents condensate formation on the heat exchanger. An appliance allowed to sustain operation at water temperatures lower than the specified minimum temperature may not provide enough heat from the burner to maintain water temperature in the heat exchanger above the 140°F (60°C) dew point of flue products. Operation of the appliance at a temperature below the specified minimum set point will result in non-warrantable operational problems from the condensate formation on the primary heat exchanger (see the *Low Temperature Bypass Requirements* section on page 42 of this manual).

CAUTION

An appliance allowed to operate at return temperatures below the specified minimum setting may experience problems with the operating controls, safety switches, obstruction of the flue gas passages on the heat exchanger, incomplete combustion and possible flue gas spillage. Sustained operation at lower than specified water temperatures may cause hazardous conditions that may result in personal injury or non-warrantable damage to the appliance.

4 Water connections

Water flow switch

A water flow switch is factory installed in the outlet piping on all heating boilers and water heaters. The flow switch must prove water flow before a trial for ignition can begin. The flow switch requires a minimum flow of 26 GPM to make the flow switch and start burner operation. A water flow switch meets most code requirements for a low water cutoff device on boilers requiring forced circulation for operation. A fault message, **Flow Sw/LWCO** will be indicated in the Operator Interface on a low water flow condition as sensed by the flow switch.

Low water cutoff

If this boiler is installed above radiation level, a low water cutoff device must be installed at the time of boiler installation. An electronic low water cutoff is available as a factory supplied option on all models. The low water cutoff should be inspected every 6 months. A fault message, **Flow Sw/LWCO** will be indicated in the Operator Interface on a low water condition as sensed by the low water cutoff.

Relief valve

This unit is supplied with a relief valve(s) sized in accordance with ASME Boiler and Pressure Vessel Code, Section IV (“Heating Boilers”). The relief valve(s) is installed in the vertical position and mounted in the hot water outlet. No valve is to be placed between the relief valve and the unit. To prevent water damage, the discharge from the relief valve shall be piped to a suitable floor drain for disposal when relief occurs. No reducing couplings or other restrictions shall be installed in the discharge line. The discharge line shall allow complete drainage of the valve and line. Relief valves should be manually operated at least once a year.

CAUTION Avoid contact with hot discharge water.

Heating boiler installations

Piping of the boiler system

The drawings in this section show typical boiler piping installations, see FIG.’s 4-3 through 4-6. Before beginning the installation, consult local codes for specific plumbing requirements. The installation should provide unions and valves at the inlet and outlet of the boiler so it can be isolated for service. An air separation device must be supplied in the installation piping to eliminate trapped air in the system. Locate a system air vent at the highest point in the system. The system must also have a properly sized expansion tank installed. Typically, an air charged diaphragm-type expansion tank is used. The expansion tank must be installed close to the boiler and on the suction side of the system pump to ensure proper operation.

CAUTION The boiler system should not be operated at less than 12 PSIG.

Hot water piping must be supported by suitable hangers or floor stands, **NOT** by the boiler. Copper pipe systems will be subject to considerable expansion and contraction. Rigid pipe hangers could allow the pipe to slide in the hanger resulting in noise transmitted into the system. Padding is recommended on rigid hangers installed with a copper system. The boiler pressure relief valve must be piped to a suitable floor drain. See the *Relief Valve* section on this page.

CAUTION A leak in a boiler “system” will cause the “system” to intake fresh water constantly, which will cause the tubes to accumulate a lime/scale build up. This will cause a non-warrantable failure.

Water connections (heating boilers only)

All boilers have 2 1/2 inch copper pipe inlet and outlet connections. Installed piping to and from the boiler must be a minimum of 2 1/2 inch diameter.

CAUTION Field installed reducing bushings must not be used.

Any reduction in pipe size may decrease flow resulting in high water temperatures, boiler noise, flashing to steam, and non-warrantable heat exchanger damage.

The boiler may be installed with either a primary/secondary piping system or with full system flow provided to the boiler. It is important to guarantee that adequate flow is provided to properly dissipate heat from the boiler and also ensure that flow through the boiler does not exceed the maximum recommended flow rate of 75 GPM for Models 502 - 1302 and 90 GPM for Models 1501 - 2001 for a boiler equipped with a copper heat exchanger.

Boiler circulator requirements

This is a low mass, high efficiency hot water boiler which must have adequate flow for quiet, efficient operation. Pump selection is critical to achieve proper operation. A pump should be selected to achieve proper system design water temperature rise. A system pump may provide full flow through the boiler or a separate pump may be installed in a secondary loop to the boiler. Pipe diameter and length are critical to ensure proper flow through the boiler. A System Temperature Rise Chart (Table 4B on page 43) is provided to assist in proper pump selection. This table provides GPM and boiler head-loss at various temperature rises for each model based on Btu/hr input. Temperature rise is the difference in boiler inlet temperature and boiler outlet temperature while the boiler is firing at full rate.

Example: The boiler inlet temperature is 160°F (71.1°C) and the boiler outlet temperature is 180°F (82.2°C). This means that there is a 20°F (11.1°C) temperature rise across the boiler. The boiler temperature rise is visible in the Operator Interface on the boiler’s front control panel.

4 Water connections *(continued)*

Circulator pump specifications

1. Maximum operating pressure for the pump must exceed system operating pressure.
2. Maximum water temperature should not exceed the nameplate rating.
3. Cast iron circulators may be used for closed loop systems.
4. A properly sized expansion tank must be installed near the boiler and on the suction side of the pump.

Circulator pump operation (heating boilers only)

The boiler pump must run when the boiler is firing. Separate supply circuits can be provided or the two circuits (pump and controls) can be combined for connection to one circuit, properly sized for both.

Intermittent pump operation

An intermittent pump operation feature is provided. The boiler's circulating pump will cycle on at each call for heat, before the burner fires. The pump will continue to operate while the burner is firing. The pump will run for a minimum 30 second period after the temperature set point is satisfied. This timing is selectable from the Operator Interface. This timing will remove any of the residual heat from the combustion chamber before turning the pump off. See the wiring diagram in Section 10 of this manual.

Pump Maintenance: Inspect the pump every six (6) months and oil as necessary. Use SAE 30 non-detergent oil or lubricant specified by the pump manufacturer.

The boiler is recommended for installation in a primary/secondary piping system. This type of system uses a separate boiler circulating pump to supply flow to and from the boiler only. The secondary pump is sized based on the head loss of the boiler and related pipe and fittings in the secondary loop only.

A properly sized primary system pump provides adequate flow to carry the heated boiler water to radiation, air over coils, etc. The fittings that connect the boiler to the primary system should be installed a maximum of 12 inches (0.30m) (or 4 pipe diameters) apart to ensure connection at a point of zero pressure drop in the primary system. There should be a minimum of 10 pipe diameters of straight pipe before and after the boiler secondary loop connections to prevent turbulent flow at the secondary loop connections. The secondary loop piping to and from the boiler must have a fully ported ball valve installed in both the supply and return side piping. The ball valves must be fully ported having the same inside diameter as the installed piping. The ball valve in the piping supplying water to the boiler will only be used as a service valve. The ball valve installed in the discharge from the boiler back to the primary system will be used to adjust boiler flow and temperature rise to ensure proper performance.

The boiler primary piping system must have a circulator installed in the main system loop to carry the heated boiler water to the point of use in the main system.

Multiple boilers may also be installed with a primary/secondary manifold system. Multiple boilers should be connected to the common manifold in reverse return to assist in balancing flow to multiple boilers.

The installer must ensure that the boiler has adequate flow without excessive temperature rise. Low system flow can result in overheating of the boiler water which can cause short burner cycles, system noise, relief valve discharge and in extreme cases, a knocking flash to steam. These conditions indicate the need to increase boiler flow to and from the boiler. This is generally accomplished by either increasing the size of the boiler pump or by increasing the diameter of the piping that connects the boiler to the primary system. A larger diameter pipe reduces head loss and increases flow.

⚠ CAUTION

At no time should the system pressure be less than 12 PSIG.

Low system water volume

System run time is very important to the overall operating efficiency of the boiler. Short cycling of the boiler creates problems with condensation in the vent stack, condensation on the heat exchanger, system temperature spikes, and mechanical component failures. To prevent short cycling of the boiler, it is important to limit the boiler cycles to six or fewer per hour.

A buffer tank is an effective way to enhance a small system load and increase heating system efficiency (see FIG. 4-6 on page 41 of this manual). Buffer tanks add water volume to the system and act as a flywheel to absorb the additional Btu's provided by the boiler when only a single zone of a large system is calling for heat.

To calculate the proper buffer tank size for a multiple zone system:

$$\frac{(\text{Run Cycle})(\text{Output} - \text{Minimum System Load})}{$$

$$(\text{Temp. Rise})(8.33)(60 \text{ Min.})$$

PBN2001-B9 (1.7:1 Turndown)

Min. Load = 100,000 Btu/Hr

Min. Boiler Output = 850,000 Btu/Hr

Cycle Time = 10 Min

Temp. Rise = 38

$$(10)(850,000 - 100,000) / (38)(8.33)(60) = 395 \text{ Gallons}$$

4 Water connections

Figure 4-3_Primary/Secondary Piping of a Single Boiler

COMMON MANIFOLD SIZE (Min.) Models: 502, 752, 1002, & 1302		
Number of Units	GPM	Diameter (in.)
1	75	2 1/2

COMMON MANIFOLD SIZE (Min.) Models: 1501, 1701, & 2001		
Number of Units	GPM	Diameter (in.)
1	90	2 1/2

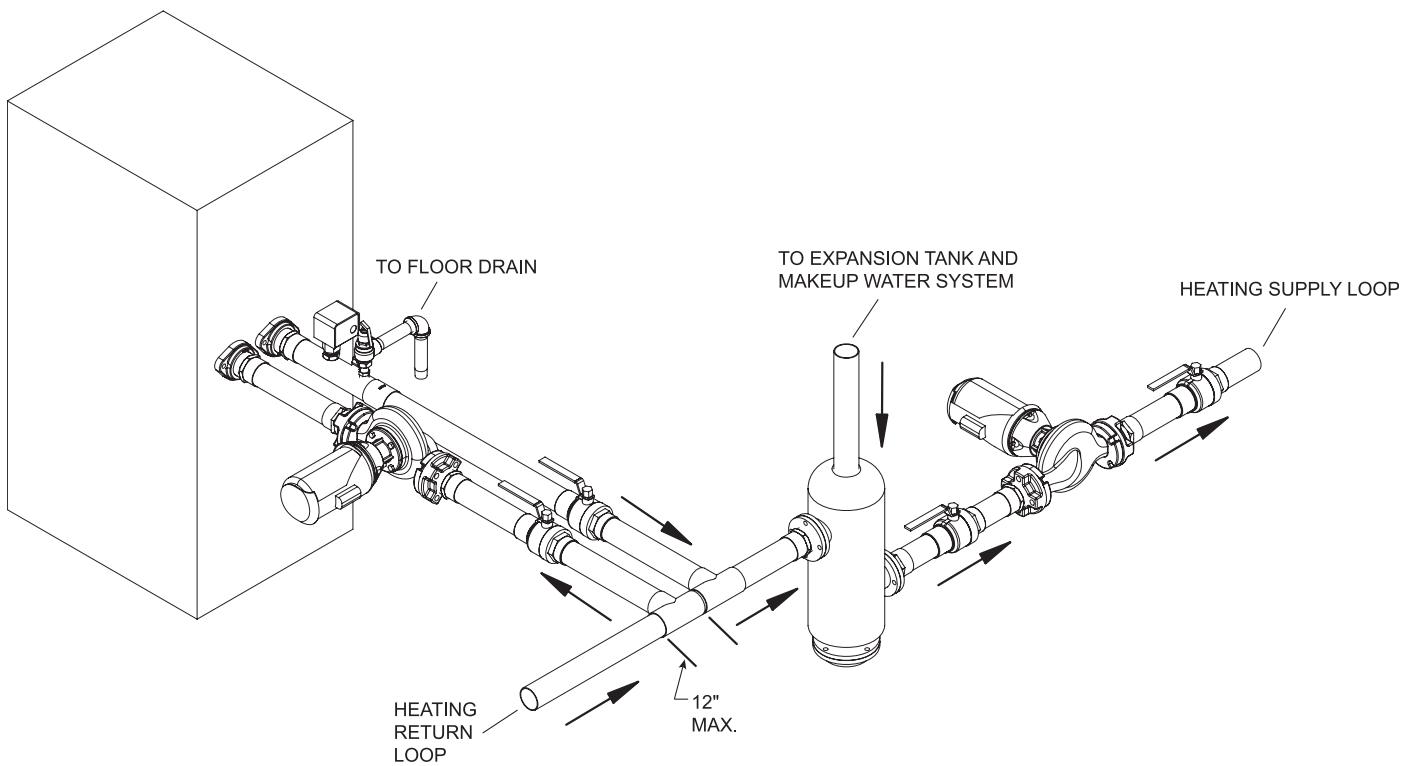

4 Water connections *(continued)*

Figure 4-4_Primary/Secondary Piping of Multiple Boilers

COMMON MANIFOLD SIZE (Min.) Models: 502, 752, 1002, & 1302		
Number of Units	GPM	Diameter (in.)
2	150	3 1/2
3	225	4
4	300	5
5	375	6
6	450	6
7	525	6
8	600	7

COMMON MANIFOLD SIZE (Min.) Models: 1501, 1701, & 2001		
Number of Units	GPM	Diameter (in.)
2	180	4
3	270	5
4	360	6
5	450	6
6	540	6
7	630	7
8	720	7

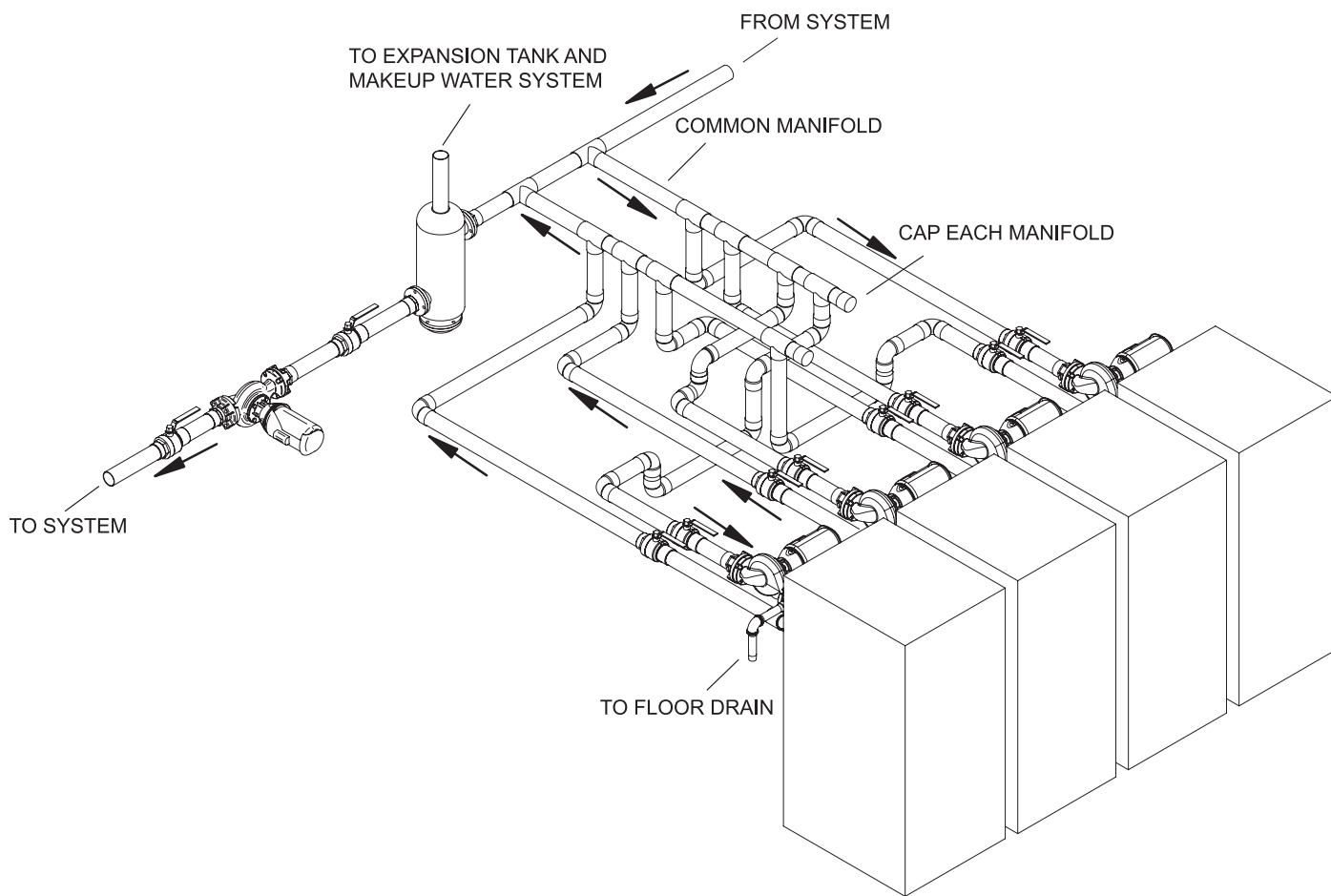

4 Water connections

Figure 4-5 Boiler with Low Temperature Bypass Piping - Using a Thermostatic Mixing Valve Required for Systems Operating at less than 140°F (60°C) Return Water Temperatures from the Heating Return Loop

COMMON MANIFOLD SIZE (Min.) Models: 502, 752, 1002, & 1302		
Number of Units	GPM	Diameter (in.)
1	75	2 1/2

COMMON MANIFOLD SIZE (Min.) Models: 1501, 1701, & 2001		
Number of Units	GPM	Diameter (in.)
1	90	2 1/2

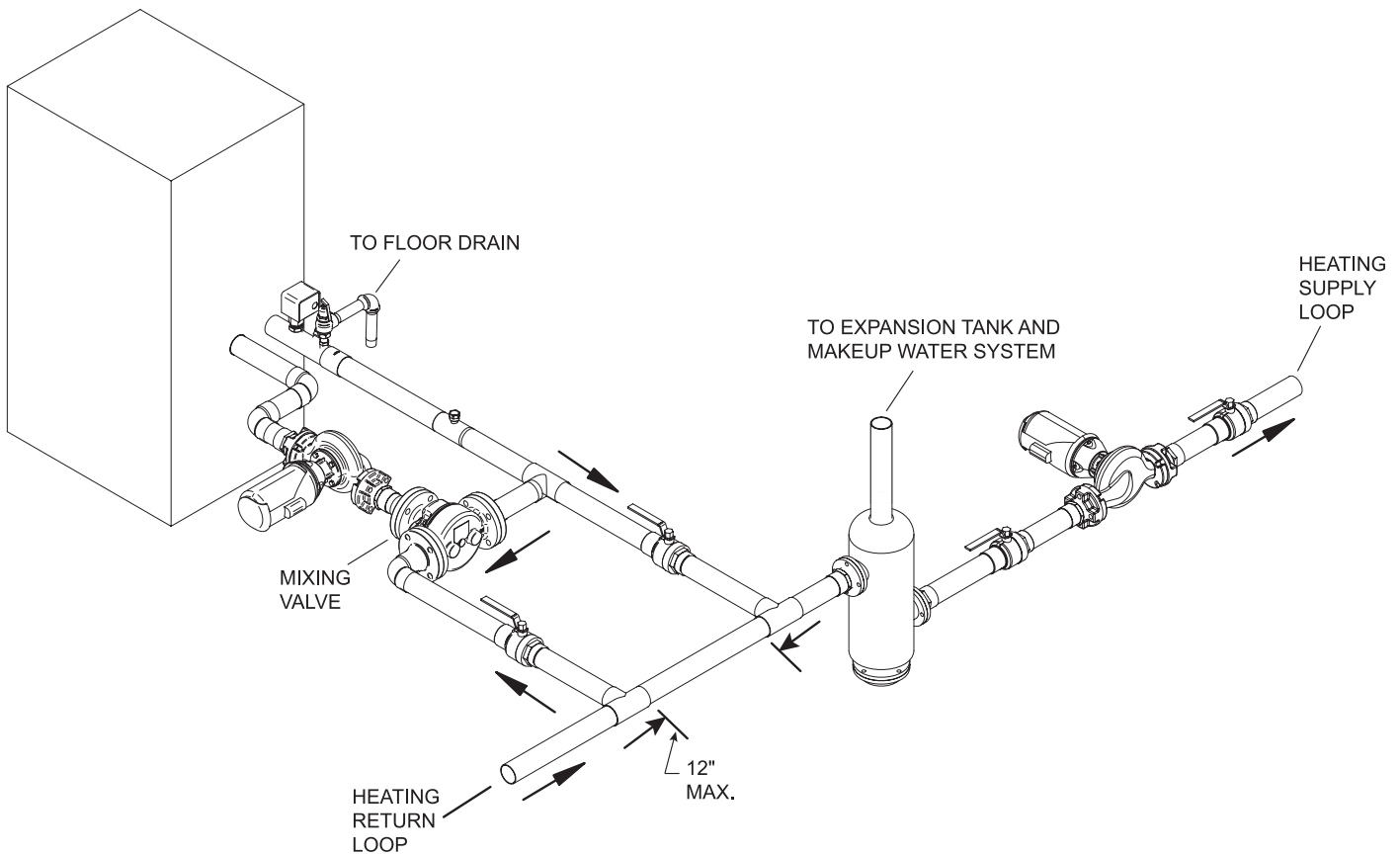

4 Water connections *(continued)*

Figure 4-6 Primary/Secondary Piping with Buffer Tank

COMMON MANIFOLD SIZE (Min.) Models: 502, 752, 1002, & 1302		
Number of Units	GPM	Diameter (in.)
2	150	3 1/2
3	225	4
4	300	5
5	375	6
6	450	6
7	525	6
8	600	7

COMMON MANIFOLD SIZE (Min.) Models: 1501, 1701, & 2001		
Number of Units	GPM	Diameter (in.)
2	180	4
3	270	5
4	360	6
5	450	6
6	540	6
7	630	7
8	720	7

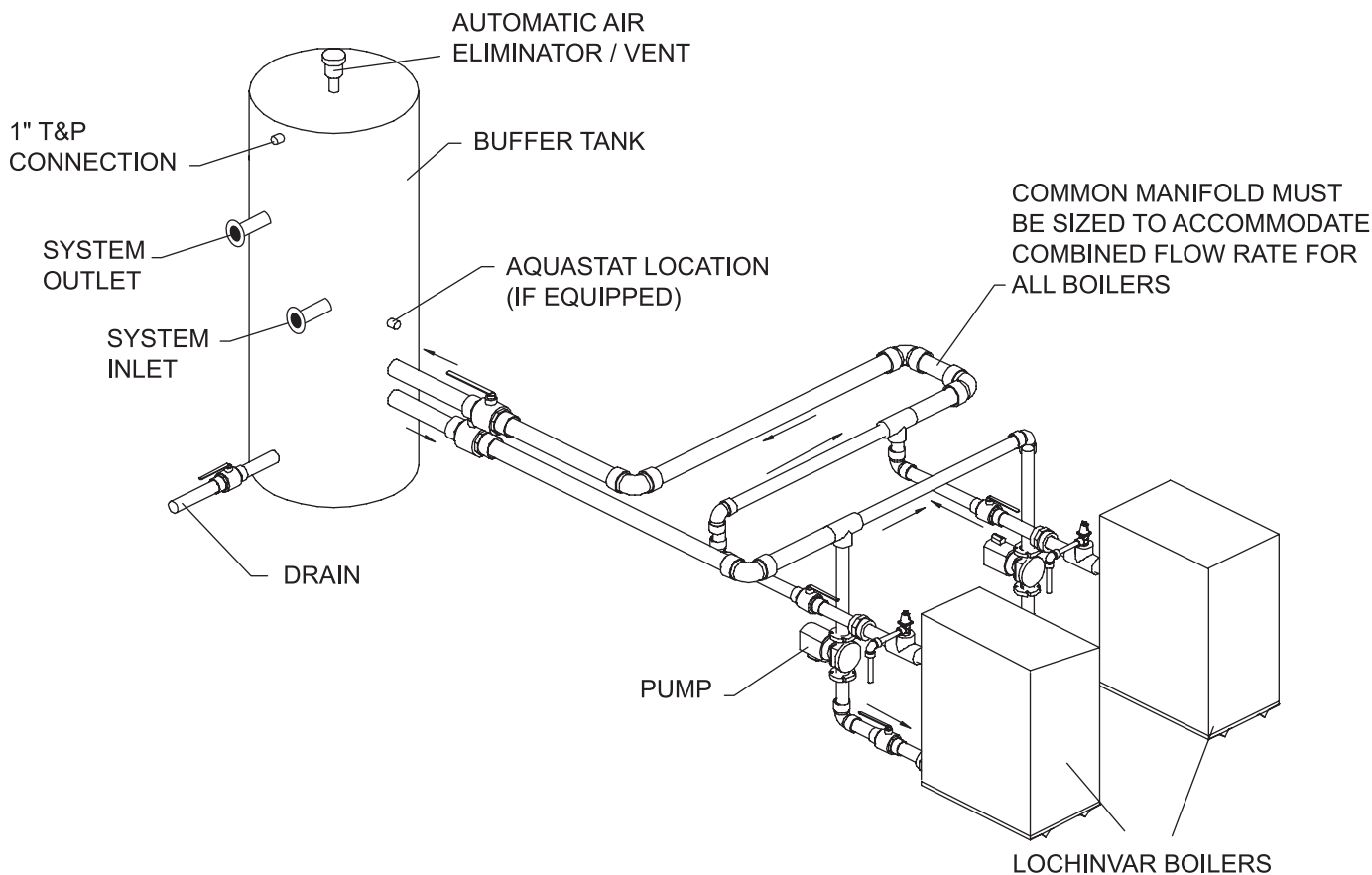

NOTICE The Inlet/Outlet System tappings are shown in the optional location on the side of the tank for pictorial purposes. The standard location for the system tappings is 180° from the recirculation tappings.

4 Water connections

Minimum boiler water temperatures

Inlet water temperatures below the specified minimum of 140°F (60°C) can excessively cool the products of combustion resulting in condensation on the heat exchanger. Condensation on the heat exchanger can cause operational problems, bad combustion, sooting, flue gas spillage and reduced service life of the related components. See the *Low Temperature Bypass Requirements* section for boiler system applications below the minimum specified temperature.

Low temperature bypass requirements

To prevent condensation problems, a boiler **MUST NOT** be operated (other than for brief periods during initial system startup) with an inlet water temperature of less than 140°F (60°C). If normal system return temperatures are less than the required 140°F (60°C) boiler inlet requirement, a method of low return water temperature protection **MUST BE** provided to protect the boiler.

For Example: *Night Setback* of the system loop water temperature, *Night Shutdown* and *Weekend Shutdown* of the entire boiler / heating system, and *Indoor / Outdoor Air Reset* of the system loop water temperature. If any of these Building Management System control functions are being utilized on the hydronic heating system, some type of low return water protection **MUST BE** provided.

If the boiler heating system will be used on a Water Source Heat Pump System, Radiant Floor Heating System, Snow Melting Heating System, etc., some type of low return water protection must be provided.

Condensation can cause operational problems, bad combustion, sooting, flue gas spillage and reduced service life of the vent system and related components.

To prevent the system return water temperature below 140°F (60°C) from entering the boiler inlet, an electrically actuated 3-way mixing valve is available, consult manufacturer for kit availability (see FIG. 4-5 on page 40). By using this valve, the SMART SYSTEM control will bypass outlet water back into the inlet of the boiler to maintain the inlet temperature above 140°F (60°C).

A fast acting, self contained mixing valve, set to 140°F (60°C), may also be used. The installation of this valve must be done as shown in FIG. 4-5. This arrangement will maintain the required flow through the boiler.

When a mixing valve is used, an optional system return sensor should be installed into the system return piping. This will allow the display of the actual system return temperature, and will also allow control of the system return temperature when the SMART SYSTEM control is programmed for inlet temperature control. As always, installation of the system supply sensor is strongly recommended as well. This will reduce the potential for short cycling of the boiler, and provide more responsive temperature regulation, even when the SMART SYSTEM control is programmed for inlet temperature control.

⚠ CAUTION

A boiler allowed to operate at set point temperatures below the specified minimum settings may experience operational problems with the operating controls and safety switches, obstruction of the flue gas passages on the heat exchanger, incomplete combustion and possible flue gas spillage. Operation at lower than specified water temperatures may cause hazardous conditions that result in non-warrantable damage to the appliance.

Three way valves in system

The installation of a three way valve on this boiler is not generally recommended because most piping methods allow the three way valve to vary flow to the boiler. This boiler is a low mass, high efficiency appliance which **requires a constant water flow rate for proper operation**. Low flow rates can result in overheating of the boiler water which can cause short burner cycles, system noise, relief valve discharge and in extreme cases, a knocking flash to steam. These conditions can cause operational problems and non-warrantable failures of the boiler.

Radiant floor and snow melt heating systems

This type of heating boiler application operates in a low temperature range which requires a boiler bypass as described under the *Low Temperature Bypass Requirements* section. A non-metallic rubber or plastic tubing installed in a radiant (in floor) system must have an oxygen barrier to prevent oxygen from entering the system through the walls of the installed tubing. Excessive oxygen absorption into the system will result in an accelerated rate of corrosion causing a sludge buildup. This excessive corrosion will also damage the boiler and system components. Sludge formed as the result of excessive oxygen in the system can restrict water flow resulting in a premature boiler failure. Any boiler damage due to excessive oxygenation is non-warrantable.

TABLE - 4A
MAXIMUM FLOW FOR HEATING BOILER

The maximum flow rate through the boiler with a copper heat exchanger must not exceed the following:

Model	Maximum Flow
502, 752, 1002, and 1302	75 GPM
1501, 1701, and 2001	90 GPM

If higher flow rates are required through the boiler, an optional Cupro-Nickel heat exchanger is available. Consult the factory for specific application requirements.

4 Water connections *(continued)*

TABLE - 4B
SYSTEM TEMPERATURE RISE CHART
 Temperature Rise and Head Loss Based on Boiler Output in Btu/hr

Btu/hr		30°F ΔT		35°F ΔT		40°F ΔT		45°F ΔT		50°F ΔT		55°F ΔT		60°F ΔT	
Input	Output	GPM	Ft/hd	GPM	Ft/hd	GPM	Ft/hd	GPM	Ft/hd	GPM	Ft/hd	GPM	Ft/hd	GPM	Ft/hd
500,000	435,000	29.0	0.9	24.9	0.7	21.8	0.5	19.3	0.4	17.4	0.3	15.8	0.2	14.5	0.1
750,000	652,500	43.5	2.1	37.3	1.8	32.6	1.3	29.0	1.0	26.1	0.8	23.7	0.7	21.8	0.6
1,000,000	870,000	58.0	4.8	49.7	3.3	43.5	2.4	38.7	2.0	34.8	1.6	31.6	1.2	29.0	1.1
1,300,000	1,131,000	75.4	9.8	64.7	6.9	56.6	4.6	50.3	3.6	45.3	2.9	41.1	2.2	37.7	1.9
1,500,000	1,275,000	87.9	9.8	75.3	7.7	65.9	6.3	58.6	5.2	52.9	4.2	47.9	3.3	43.9	2.7
1,700,000	1,445,000	99.6*	14.1	85.4	10.2	74.7	7.9	66.4	6.5	59.8	5.3	54.3	4.6	49.8	3.9
2,000,000	1,700,000	117.2*	20.2	100.4*	14.9	87.9	11.9	78.1	9.2	70.3	7.2	63.9	6.4	58.6	5.2

*Cupro-Nickel Heat Exchanger Required at Flows Above 75 GPM on Models 502 - 1302 and above 90 GPM on Models 1501 - 2001.

TABLE - 4C
BOILER TEMPERATURE RISE AT MAXIMUM FLOW
 Temperature Rise at Full Rate Fire, 75 and 90 GPM
 Maximum Flow

Model	Temperature Rise
502	11°F (6.1°C)
752	17°F (9.4°C)
1002	23°F (12.8°C)
1302	30°F (16.7°C)
1501	28°F (15.6°C)
1701	32°F (17.8°C)
2001	38°F (21.1°C)

Boiler bypass requirements

The installer must ensure that the boiler is supplied with adequate flow without excessive temperature rise. It is recommended that this boiler be installed with a bypass in the piping if the maximum recommended flow rate is exceeded. The bypass will help to ensure that the boiler can be supplied with adequate water flow. Flow rates exceeding the maximum recommended flow will result in erosion of the boiler tubes. A typical bypass with a valve as shown in FIG. 4-5 will allow control of boiler flow.

Temperature / pressure gauge

This boiler is equipped with a dial type temperature / pressure gauge. This gauge is factory installed in the outlet side of the boiler piping. The gauge has one scale to read system pressure and a separate scale to read water temperature in degrees Fahrenheit. The temperature / pressure gauge is provided to meet code requirements. Water temperatures can be more accurately monitored from the data provided in the digital display in the Operator Interface.

Typical heating boiler installations

General plumbing rules:

1. Check all local codes.
2. For serviceability of boiler, always install unions.
3. Always pipe pressure relief valve to an open drain.
4. Locate system air vents at highest point of system.
5. Expansion tank must be installed near the boiler and on the suction side of the system pump.
6. Support all water piping.

Installation with a chilled water system

Pipe refrigeration systems in parallel. Install duct coil downstream at cooling coil. Where the hot water heating boiler is connected to a heating coil located in the air handling units which may be exposed to refrigeration air circulation, the boiler piping system must be equipped with flow control valves or other automatic means to prevent gravity circulation of the boiler water during the cooling cycle.

The coil must be vented at the high point and hot water from the boiler must enter the coil at this point. Due to the fast heating capacity of the boiler, it is not necessary to provide a ductstat to delay circulator operation. Also, omit thermostat flow checks as the boiler is cold when heating thermostat is satisfied. This provides greater economy over maintaining standby heat.

5 Electrical connections

Boiler operating control module

The operating temperature control for the appliance is the SMART SYSTEM control module. It is located on the inside of the control panel, behind the front access door. Access to adjust the temperature set point and other user adjustable points is made through the Operator Interface located on the right front access door. The outlet sensor is placed in a bulbwell installed in the outlet side of the heat exchanger top header. The inlet sensor is located in a bulbwell on the inlet side of the heat exchanger top header.

The operating sensor, inlet or outlet, is selectable from the screen in the Operator Interface.

The exact temperature set point is based on your system's requirements. Set the control set point(s) to the desired operating water temperature.

The maximum temperature set point that can be programmed into the standard control module from the Operator Interface on a heating boiler is 220°F (104.4°C). The manual reset high limit control for a heating boiler is adjustable up to a fixed maximum setting of 230°F (110°C).

The maximum temperature set point for a water heater is 190°F (88°C). The auto reset high limit is fixed at 200°F (93°C), and the adjustable manual reset high limit has a maximum setting of 230°F (110°C).

A 120 VAC, 15 Amp, 1 ph, 60 Hz circuit is required for operation of the appliance controls.

The appliance, when installed, must be electrically grounded in accordance with the requirements of the authority having jurisdiction or in the absence of such requirements, with the latest edition of the National Electrical Code ANSI/NFPA No. 70. When the unit is installed in Canada, it must conform to the CAE C22.1, Canadian Electrical Code, Part I and/or local Electrical Codes. Multiple units connected in a Cascade must be grounded to the same ground connection.

1. All wiring between the appliance and field installed devices shall be made with type T wire [63°F (35°C) rise].
2. All line voltage wire exterior to the appliance must be enclosed in approved conduit or approved metal clad cable.
3. The circulating pump must run continuously when the appliance is being fired.
4. To avoid serious damage, DO NOT energize the appliance until the system is full of water. Ensure that all air is removed from the heat exchanger and piping before beginning initial operation. Serious damage may result if the appliance is operated without proper flow.
5. Provide the appliance with proper overload protection.

TABLE - 5A
AMP DRAW DATA

Model	Blower & Controls	Pump FLA*	Approximate Total Amps @ 120 VAC
502	6.7	8.8	15.5
752	6.7	8.8	15.5
1002	6.7	8.8	15.5
1302	6.7	8.8	15.5
1501	6.5	8.8	15.3
1701	6.5	8.8	15.3
2001	6.5	8.8	15.3
*Standard Pump Supplied with Water Heaters Only			

⚠ WARNING ELECTRICAL SHOCK HAZARD – For your safety, turn off electrical power supply before making any electrical connections to avoid possible electric shock hazard. Failure to do so can cause severe personal injury or death.

NOTICE Wiring must be N.E.C. Class 1.

If original wiring as supplied with the boiler must be replaced, use only type 105°C wire or equivalent.

Boiler must be electrically grounded as required by National Electrical Code ANSI/NFPA 70 – latest edition.

⚠ CAUTION Label all wires prior to disconnection when servicing controls. Wiring errors can cause improper and dangerous operation.

5 Electrical connections *(continued)*

Installation must comply with:

1. National Electrical Code and any other national, state, provincial, local codes, or regulations.
2. In Canada, CSA C22.1 Canadian Electrical Code Part 1, and any local codes.

Line voltage connections

1. Connect 120 VAC power wiring to the line voltage terminal strip in the junction box, as shown in FIG. 5-1.
2. Provide and install a fused disconnect or service switch (15 AMP recommended) as required by the code (see FIG. 5-1).
3. To activate a system pump, wire as shown in FIG. 5-1. If the motor is larger than 1 HP, you must install a contactor.
4. When connecting power to units which are to be cascaded, each unit must be connected to the same ground connection.

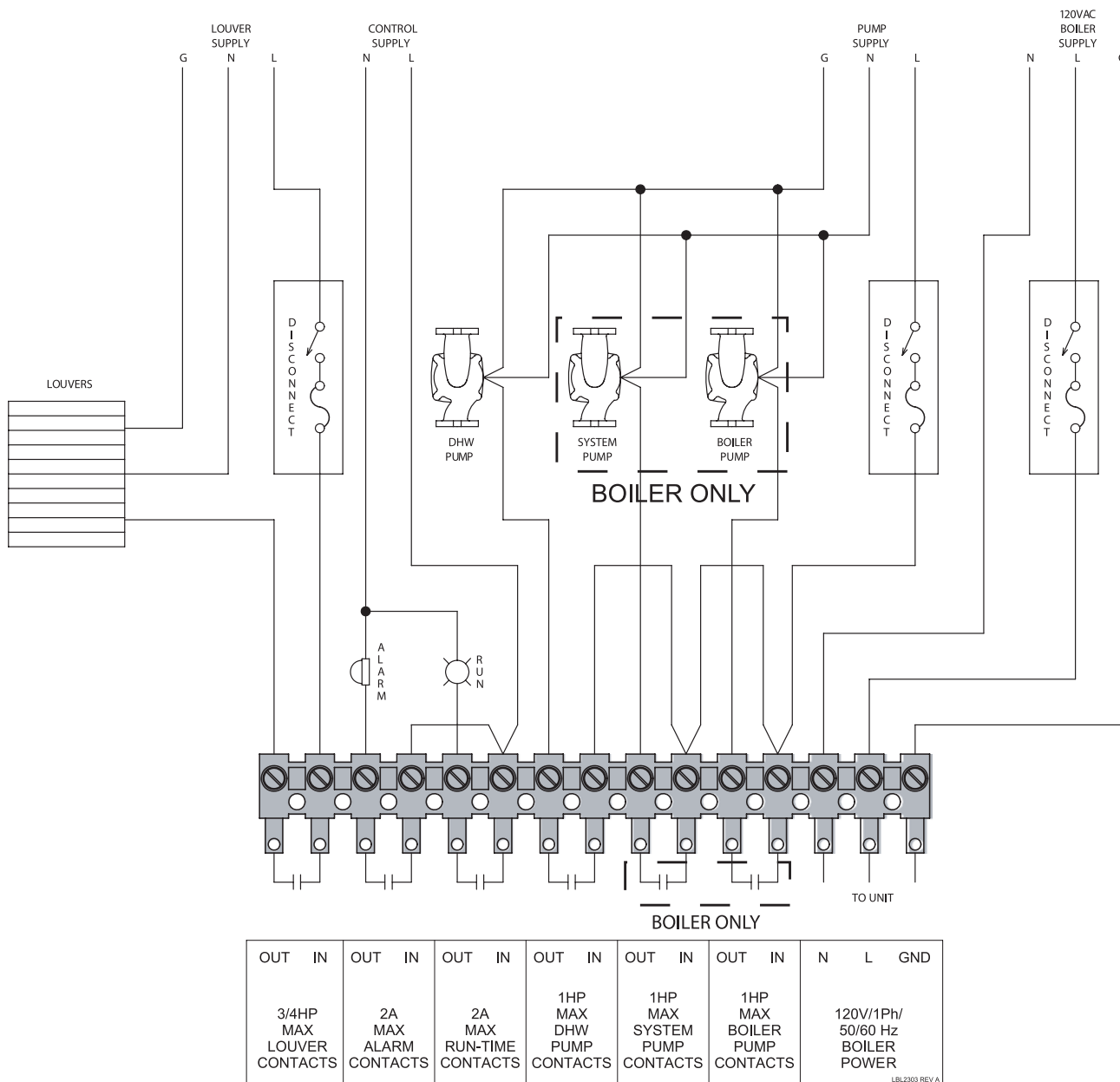

Figure 5-1 Line Voltage Field Wiring Connections

5 Electrical connections

Low voltage connections

1. Route all low voltage wires through the knockouts in the rear of the heater, as shown in FIG. 5-2.
2. Connect low voltage wiring to the low voltage connection board as shown in FIG. 5-4 on page 48 of this manual and the heater wiring diagram.

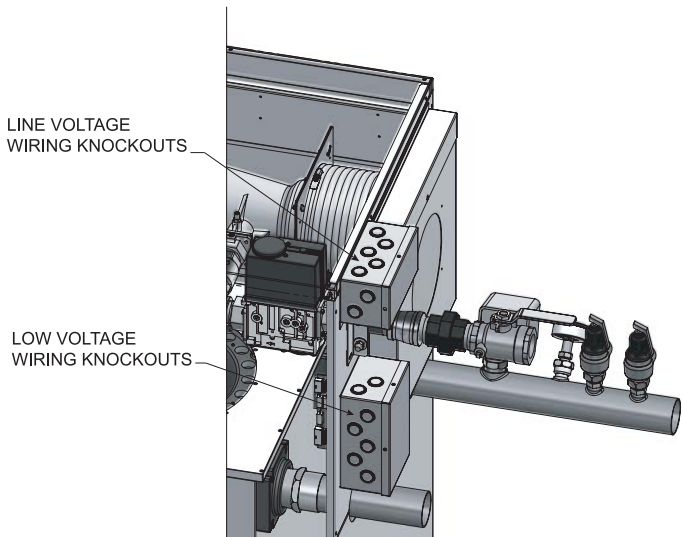

Figure 5-2_Routing Field Wiring

EMS or remote thermostat connection

An EMS, remote thermostat or other remote temperature control may be connected to the boiler (see FIG. 5-3). Follow the manufacturer's instructions supplied with the remote temperature control for proper installation and adjustment. Connection of a set of dry switching contacts or a remote on/off thermostat to the low voltage connection board will allow the unit to be switched on and off by making or breaking a 24 VAC control circuit. Remove the factory jumper between the enable terminals on the low voltage connection board and connect the remote temperature control in its place, see FIG. 5-4 on page 48.

Ensure that all wiring used to connect the switching contacts of the remote temperature controller to the connection board are a minimum of 18 gauge and have a maximum installed length of 300 feet (91.4m). Set the SMART SYSTEM control to a set point temperature slightly higher than the setting of the remote temperature control. This will ensure that the remote temperature controller functions as the operating control for the heater.

REMOTE ON/OFF
WIRE CONNECTION

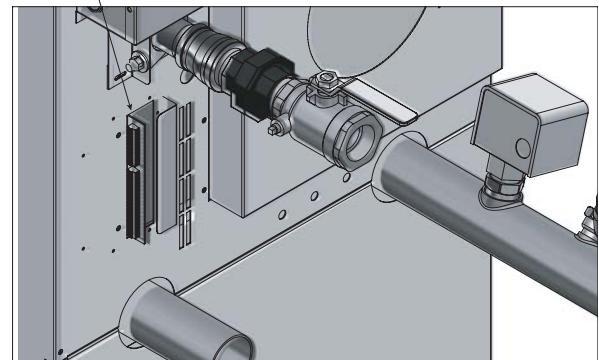

Figure 5-3_Remote ON/OFF Wire Connection

DHW (Domestic Hot Water) thermostat

1. Connect the DHW tank thermostat (FIG. 5-4) to the tank thermostat terminals on the connection board.

DHW tank sensor

If a tank sensor is used, it must be connected to the tank sensor terminals on the low voltage connection board. The correct Lochinvar sensor (TST2032) MUST BE USED.

5 Electrical connections *(continued)*

Louver proving switch

1. When the operation of a louver proving switch needs to be verified before the boiler fires, remove the jumper wire from these terminals and connect them to the normally open contacts on its proving switch (FIG. 5-4).

System supply sensor

1. By installing the system supply sensor into the supply of the primary loop, the temperature of the primary supply can be controlled. The SMART SYSTEM control automatically detects the presence of this sensor, and controls the boiler firing rate to maintain the system supply temperature to the set point (if the outlet sensor control is currently selected).
2. Connect these terminals to the system supply sensor (FIG. 5-4).

System return sensor

1. By installing the system return sensor into the return of the primary loop, the temperature of the primary return can be sensed when a 3-way valve or other device is installed ahead of the heater inlet. The SMART SYSTEM control automatically senses the presence of this sensor. If the inlet sensor is selected as the controlling sensor, the SMART SYSTEM control will adjust the firing rate to hold the system return temperature to the set point. It is strongly recommended that the system supply sensor be installed as well.
2. Connect these terminals to the system return sensor (FIG. 5-4).

Boiler Management System (BMS)

1. An external control may be connected to control either the firing rate or the set point of the appliance. Connect the 0 - 10 VDC terminals to the 0 - 10 VDC output of the external control. The SMART SYSTEM control can be programmed to use the enable output of the Boiler Management System, or use the voltage signal to enable the heater. Connect the enable terminals to the enable output of the BMS, when used.
2. Make sure the ground terminal is connected to the ground output terminal of the external control, and the 0 - 10 VDC terminal is connected to the 0 - 10 VDC terminal of the external control.

Runtime contacts

The SMART SYSTEM control closes a set of dry contacts whenever the burner is running. This is typically used by Building Management Systems to verify that the boiler is responding to a call for heat.

Alarm contacts

The SMART SYSTEM control closes another set of contacts whenever the heater is locked out or the power is turned off. This can be used to turn on an alarm, or signal a Building Management System that the boiler is down.

Wiring of the cascade

When wiring the heaters for Cascade operation, select one heater as the Leader heater. The remaining heaters will be designated as Members. See page 55 *Configuration of the Cascade* for a detailed explanation of this procedure.

On boilers, connect the system supply sensor and outdoor air sensor (if used) to the Leader boiler. The location of the system supply sensor should be downstream of the boiler connections in the main system loop (FIG.'s 4-3 and 4-6). The system supply sensor should be wired to the low voltage connection board at the terminals marked for the system supply sensor (see FIG. 5-4). The Leader control will use the water temperature at the system supply sensor to control the operation of the Cascade.

If outdoor air reset is desired, the outdoor air sensor should be wired to the low voltage connection board at the terminals marked for the outdoor air sensor (FIG. 5-4). If the outdoor air sensor is connected, the Leader control will calculate the water temperature set point based on the programmed reset curve parameters. If the outdoor air sensor is not connected, the Leader control will maintain the space heating (SH) set point that is programmed into the control.

If a Thermostat, Zone Control enable output, or Building Management System enable output are available, it should be wired to the low voltage connection board on the Leader boiler at the enable terminals. If the boilers are to run continuously, leave the jumper wire between the enable terminals. This will initiate a call for heat on the Cascade. Also, leave the jumpers on the enable terminals of all the Member heaters. This will allow them to run independently should the Leader heater fail.

On water heaters, connect the tank thermostat or BMS enable output to the low voltage connection board on the Leader heater, at the terminals marked for the tank thermostat. If a tank sensor is used, connect this sensor to the low voltage connection board on the Leader heater, at the terminals marked for the tank sensor.

Communication between the Leader heater and the Member heaters is accomplished by using shielded, 2-wire twisted pair communication cable. Connect one of the twisted pair wires to terminal A on each of the low voltage connection boards, and the other wire of the twisted pair to terminal B on each of the low voltage connection boards. Connect the shield wire to the shield ground terminal on all of the heaters. If more than two heaters are on the Cascade, daisy chain the wiring from the Cascade terminals on the second heater to the Cascade terminals on the third heater, then from the third to the fourth, and so on. The connections can be made in any order, regardless of the addresses of the heaters. Try to keep each cable as short as possible.

5 Electrical connections

Figure 5-4_Low Voltage Field Wiring Connections

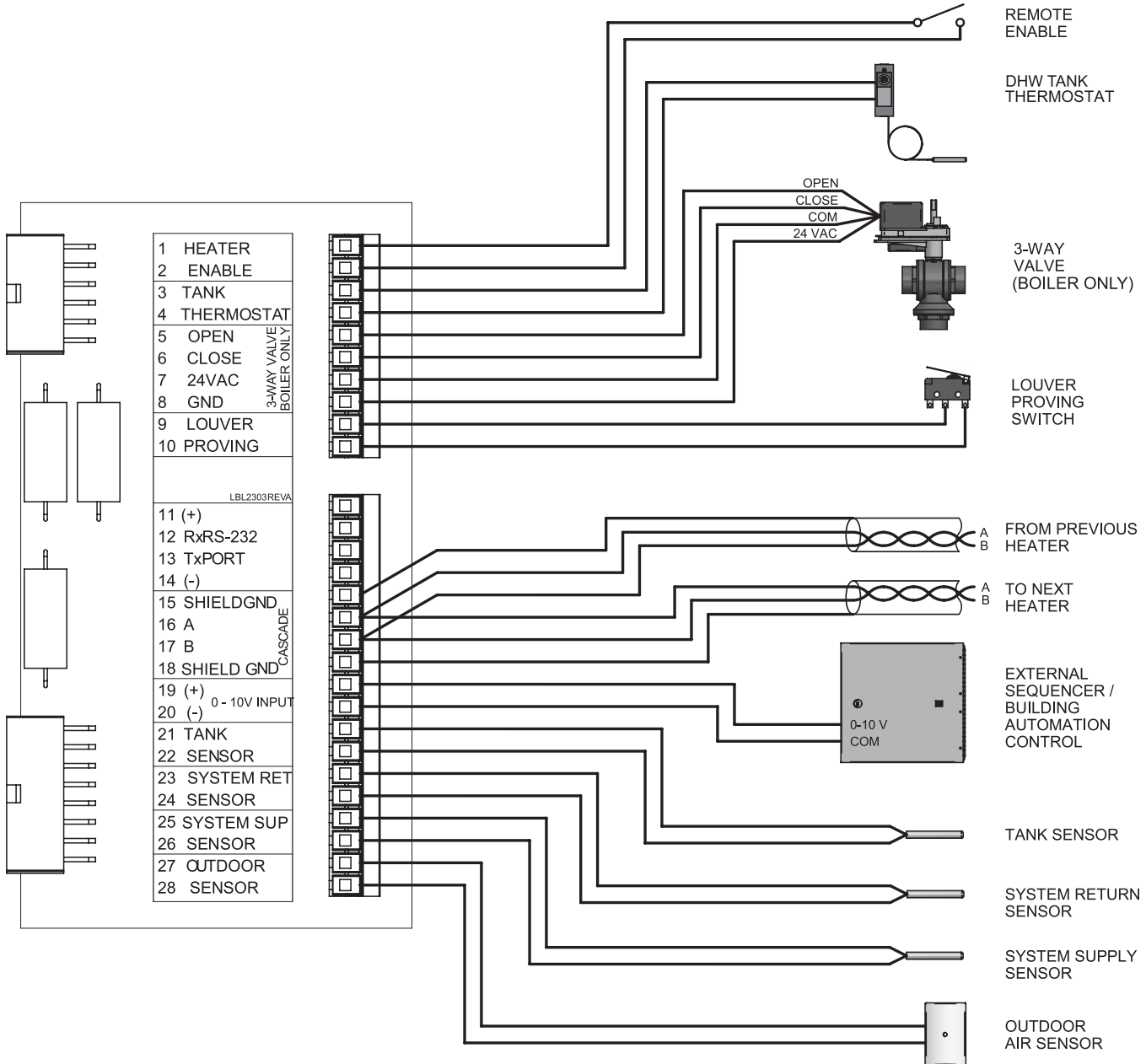

6 Condensate disposal

Condensate trap installation

1. Locate the condensate trap kit shipped loose with the appliance. The kit includes a sheet metal mounting base, two (2) nuts and the condensate trap.
2. Install the condensate trap mounting base on the rear of the appliance in the lower left-hand corner as depicted in FIG. 6-1. Use the pre-drilled holes on the appliance to secure the mounting base to the appliance.
3. Secure the condensate trap to the base using the two (2) nuts supplied with the kit. The trap should be oriented so that the barb connections are pointing toward the appliance (FIG. 6-1).
4. Use a level to ensure that the condensate trap is level on its base. Failure to keep the condensate trap level can result in the spillage of flue products from the condensate trap.
5. Locate the two hoses exiting the back of the appliance. Attach the larger hose on the appliance to the lower barb connection on the condensate trap. Secure the hose to the barb with a field supplied hose clamp (FIG. 6-1).
6. Attach the smaller hose on the unit to the upper barb connection on the condensate trap. Secure the hose to the barb connection with a field supplied hose clamp (FIG. 6-1).
7. Route the 3-pin wiring harness from the condensate trap to the matching connector on the lower back of the appliance as shown in FIG. 6-1. This is the blocked drain safety switch. This switch will shut the appliance off if the condensate trap becomes too full of liquid.
8. Remove the four (4) screws securing the top cover to the condensate trap and remove the cover (FIG. 6-1).
9. Locate the plastic ball inside the float tube. Verify there is nothing under the ball causing it to not seat properly (FIG. 6-1).
10. Fill with fresh water until the water begins to pour out of the drain.
11. Replace the cover.
12. Replace the four (4) screws removed in Step 8.
13. A 1/2" pipe connection is supplied on the condensate trap. Connect a suitable pipe or tube to this connection (see FIG. 6-1).

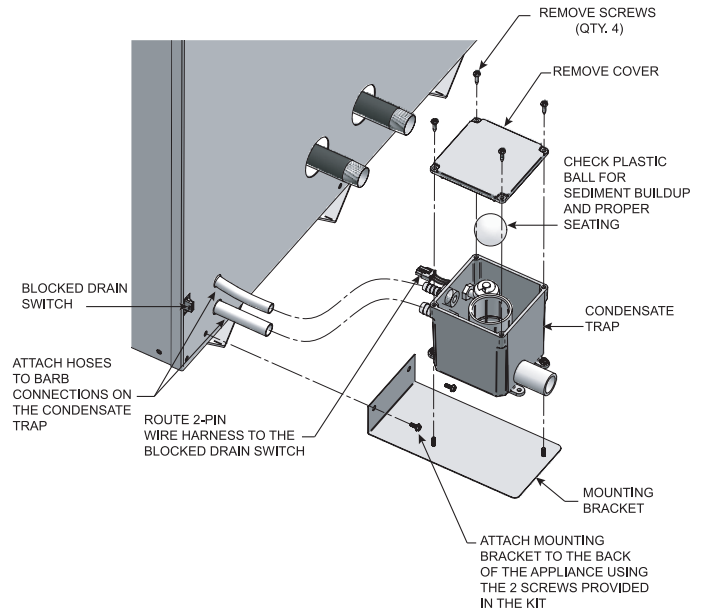

Figure 6-1_Install Condensate Trap

WARNING

Use a level to ensure that the condensate trap is level on its base. Failure to keep the condensate trap level can result in the spillage of flue products from the condensate trap.

Failure to follow this warning could result in product damage or improper operation, personal injury, or death.

NOTICE

Use materials approved by the authority having jurisdiction. In the absence of other authority, PVC and CPVC pipe must comply with ASTM D1785 or D2845. Cement and primer must comply with ASME D2564 or F493. For Canada use CSA or ULC certified PVC or CPVC pipe, fittings, and cement.

14. Slope the condensate line down and away from the appliance into a drain or condensate neutralizing filter. Do not expose the condensate line to freezing temperatures.

NOTICE

The condensate line must remain unobstructed, allowing free flow of condensate. If condensate is allowed to freeze in the line or if the line is obstructed in any other manner, the blocked drain safety switch will prevent the appliance from firing.

7 Start-up

Check/control water chemistry

⚠ CAUTION

Do not use petroleum-based cleaning or sealing compounds in the boiler system. Damage to elastomer seals and gaskets in the system could occur, resulting in substantial property damage.

Hardness less than 7 grains

1. Consult local water treatment companies for hard water areas (above 7 grains hardness).

Chlorine concentration less than 200 ppm

1. Do not fill boiler or operate with water containing chlorine in excess of 200 ppm.
2. Filling with chlorinated fresh water should be acceptable since drinking water chlorine levels are much lower.
3. Do not use the boiler to directly heat swimming pool or spa water.

Test/replace freeze protection fluid

1. For systems using freeze protection fluids, follow fluid manufacturer's instructions.
2. Freeze protection fluid must be replaced periodically due to degradation of inhibitors over time. Follow all fluid manufacturer's instructions.

Freeze protection (when used)

1. Determine freeze protection fluid quantity using system water content, following fluid manufacturer's instructions. Appliance water content is listed on page 5. Remember to include expansion tank water content.
2. Local codes may require a backflow preventer or actual disconnect from city water supply.
3. When using freeze protection fluid with automatic fill, install a water meter to monitor water makeup. Freeze protection fluid may leak before the water begins to leak, causing concentration to drop, reducing the freeze protection level.

Fill and test water system

1. Fill system only after ensuring the water meets the requirements of this manual.
2. Close manual and automatic air vents and boiler drain valve.
3. Fill to correct system pressure. Correct pressure will vary with each application.
 - a. The minimum cold water fill pressure should be 12 PSI.
 - b. Pressure will rise when boiler is turned on and system water temperature increases.

4. At initial fill and during boiler startup and testing, check system thoroughly for any leaks. Repair all leaks before proceeding further.

⚠ WARNING

Eliminate all system leaks. Continual fresh makeup water will reduce boiler life. Minerals can build up in the heat exchanger, reducing heat transfer, overheating the heat exchanger, and causing heat exchanger failure.

Purge air from water system

1. Purge air from system:
 - a. Connect a hose to the purge valve (see purge/drain valves, in the piping diagrams on pages 38 -41). Route the hose to an area where water can drain and be seen.
 - b. Close the boiler or system isolation valve between the purge valve and fill connection to the system.
 - c. Close zone isolation valves.
 - d. Open quick-fill valve on cold water makeup line.
 - e. Open purge valve.
 - f. One zone at a time, open the isolation valves. Allow water to run through the zone, pushing out the air. Run until no noticeable air flow is present. Close the zone isolation valves and proceed with the next zone. Follow this procedure until all zones are purged.
 - g. Close the quick-fill water valve and purge valve and remove the hose. Open all isolation valves. Watch that system pressure rises to correct cold-fill pressure.
 - h. After the system has operated for a while, eliminate any residual air by using the manual air vents located throughout the system.
 - i. If purge valves are not installed in the system, open the manual air vents in the system one at a time, beginning with the lowest floor. Close the vent when water squirts out. Repeat with remaining vents.
2. Open automatic air vent (diaphragm-type or bladder-type expansion tank systems only) one turn.
3. Open other vents:
 - a. Starting on the lowest floor, open air vents one at a time until water squirts out.
 - b. Repeat with remaining vents.
4. Refill to correct pressure.

7 Start-up *(continued)*

Check for gas leaks

⚠ WARNING Before starting the boiler, and during initial operation, smell near the floor and around the boiler for gas odorant or any unusual odor. Remove the front access panel and smell the interior of the boiler enclosure. Do not proceed with startup if there is any indication of a gas leak. Use an approved leak detection solution. Repair any leaks at once.

⚠ WARNING Propane boilers only – Your propane supplier mixes an odorant with the propane to make its presence detectable. In some instances, the odorant can fade, and the gas may no longer have an odor. Before startup (and periodically thereafter), have the propane supplier verify the correct odorant level in the gas.

Check thermostat circuit(s)

1. Disconnect the two external wires connected to the enable terminals on the connection board.
2. Connect a voltmeter across these two incoming wires. Close each thermostat, zone valve, and relay in the external circuit one at a time and check the voltmeter reading across the incoming wires.
3. There should NEVER be a voltage reading.
4. If a voltage does occur under any condition, check and correct the external wiring. (This is a common problem when using 3-wire zone valves.)
5. Once the external thermostat circuit wiring is checked and corrected if necessary, reconnect the external thermostat circuit wires to the connection board. Allow the boiler to cycle.

Inspect/fill condensate system

Inspect/check condensate lines and fittings

1. Inspect the condensate drain line, condensate PVC fittings and condensate trap.

Fill condensate trap with water

1. Remove the four (4) screws securing the top cover to the condensate trap and remove the cover (FIG. 7-1).
2. Locate the plastic ball inside the float tube. Verify there is nothing under the ball causing it to not seat properly.
3. Fill with fresh water until the water begins to pour out of the drain.
4. Replace the cover.
5. Replace the four (4) screws removed in Step 1.

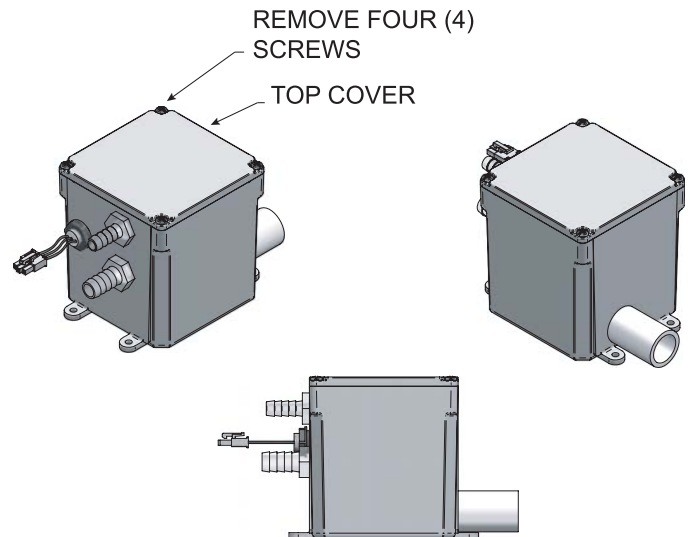

Figure 7-1_Condensate Trap

⚠ WARNING

The condensate trap (FIG. 7-1) must be filled with water during all times of boiler operation to avoid flue gas emission from the condensate drain line. Failure to fill the trap could result in severe personal injury or death.

7 Start-up

Check vent and air piping

1. Inspect vent piping and air piping for signs of deterioration from corrosion, physical damage or sagging. Verify air piping and vent piping are intact and correctly installed per this manual.

Placing the boiler in operation

Boiler operational checks

2. Turn the boiler main power switch to the "ON" position.
3. Verify operation of the SMART SYSTEM control module and Operator Interface.
4. Program the adjustable points from the Operator Interface.
5. Push the reset for the low water cutoff (if equipped).
6. Ensure that maximum flow to the boiler does not exceed 75 GPM on Models 502 - 1302 and 90 GPM on Models 1501- 2001. Verify by checking temperature rise while burner is firing at 100% of rated input.
7. Install a manometer on the gas supply to the boiler and verify minimum gas supply pressure as the burner fires at 100% of rated input.
8. Verify operation of safeties as necessary (low water cutoff, high limit, gas pressure, etc.,).
9. Verify that all adjustable points in the Operator Interface are set as required.

Boiler operation

10. Boiler should begin the start-up process for the sequence of operation.
11. The boiler will ignite at the proper ignition speed and will then modulate (B9/M9 models only) to meet the system demand.
12. Ensure that inlet water temperature does not fall below the specified minimum for the boiler.
13. Based on system demand, B9/M9 boilers may run for an extended period of time at a reduced rate of input to maximize efficiency.
14. As system demand is satisfied, the burner will cycle off and the combustion air blower will run for a post purge operation before the boiler shuts down.

Start the boiler

1. Read and follow the Operating instructions in FIG. 7-2, on page 53.

If boiler does not start correctly

1. Check for loose connections, blown fuse or service switch off?
2. Is external limit control (if used) open? Is boiler water temperature above 200°F (93.3°C)?
3. Is thermostat set below room temperature?
4. Is gas turned on at meter or boiler?
5. Is incoming gas pressure less than 4 inches water column?

If none of the above corrects the problem, refer to the Troubleshooting Section of the Power-fin Service Manual.

⚠ WARNING

The venting system must be installed so that it will prevent flue gas spillage and carbon monoxide emissions, which will result in severe personal injury or death.

7 Start-up *(continued)*

Figure 7-2_Operating Instructions

FOR YOUR SAFETY READ BEFORE OPERATING

WARNING: If you do not follow these instructions exactly, a fire or explosion may result causing property damage, personal injury, or loss of life.

- A. This appliance does not have a pilot. It is equipped with an ignition device which automatically lights the burner. Do not try to light the burner by hand.
- B. BEFORE OPERATING smell all around the appliance area for gas. Be sure to smell next to the floor because some gas is heavier than air and will settle on the floor.
- WHAT TO DO IF YOU SMELL GAS**
- Do not try to light any appliance.
 - Do not touch any electric switch; do not use any phone in your building.
- C. Use only your hand to turn the gas control knob. Never use tools. If the handle will not turn by hand, don't try to repair it, call a qualified service technician. Force or attempted repair may result in a fire or explosion.
- D. Do not use this appliance if any part has been under water. Immediately call a qualified service technician to inspect the appliance and to replace any part of the control system and any gas control which has been under water.
- Immediately call your gas supplier from a neighbor's phone. Follow the gas supplier's instructions.
- If you cannot reach your gas supplier, call the fire department.

OPERATING INSTRUCTIONS

1. **STOP!** Read the safety information above on this label.
2. Set the thermostat to lowest setting.
3. Turn off all electric power to the appliance.
4. This appliance is equipped with an ignition device which automatically lights the burner. Do not try to light the burner by hand.
5. Turn gas shutoff valve located on rear of unit clockwise to close valve. Handle will be perpendicular to pipe. Do not force.
6. Wait five (5) minutes to clear out any gas. If you then smell gas, **STOP!** Follow "B" in the safety information above this label. If you don't smell gas, go to next step.
7. Turn gas shutoff valve counterclockwise to open valve. Handle will be parallel to pipe.
8. Turn on all electric power to appliance.
9. Set thermostat to desired setting.
10. If the appliance will not operate, follow the instructions "To Turn Off Gas To Appliance" and call your service technician or gas supplier.

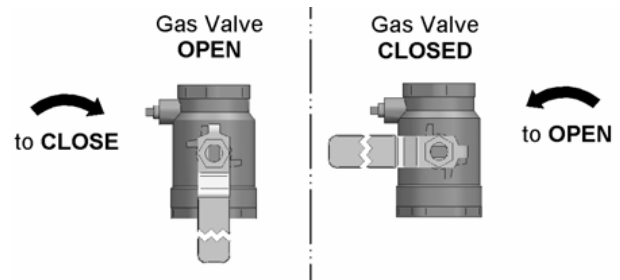

TO TURN OFF GAS TO APPLIANCE

1. Set the thermostat to lowest setting.
2. Turn off all electric power to the appliance if service is to be performed.
3. Turn gas shutoff valve located on rear of unit clockwise to close valve. Handle will be perpendicular to pipe. Do not force.
4. Install top cover.

LBL2740 REV A

7 Start-up

Set space heating operation (boiler only)

Determine controlling sensor

For space heating systems, the temperature control can be based on one of four sensors; the **inlet, outlet, system supply sensor, or system return sensor**. The SMART SYSTEM control is programmed at the factory to control the temperature of the outlet sensor. The control will automatically switch to the system supply sensor once it is connected. If it is desired to base the temperature control on the inlet sensor, the appropriate parameter must be changed in the control. See the Power-fin Service Manual for a detailed explanation of this procedure. The control will automatically switch to the system return sensor once it is connected. It is recommended that a system supply sensor be installed even when using the inlet sensor as the controlling sensor.

Verify space heat circulator mode

The Space Heating Mode controls both the system (primary) pump (if connected), and the boiler (secondary) pump. When the SMART SYSTEM control receives a space heating call for heat, it turns on the system pump. If the boiler is not heating an indirect DHW (Domestic Hot Water) tank, it also turns on the boiler pump. After the space heating call for heat ends, the system pump continues to run for a short period of time. If the boiler pump was running, it continues to run for a short period of time as well. These pump delays are factory set to 30 seconds. If different delays are desired, the appropriate parameters in the control must be changed. See the Power-fin Service Manual for a detailed explanation of this procedure.

Set space heating set point temperature

The UP and DOWN keys may be used during normal operation to adjust the space heating set point temperature (see FIG. 8-1 on page 62 of this manual). Once the desired temperature is displayed, press the ENTER/RESET key to save the new setting. If the ENTER/RESET key is not pressed, the new setting will be used for the current heating cycle only. The old setting will become active after the current heating cycle ends.

Set DHW operation

Verify DHW circulator mode (boiler only)

The DHW Mode is programmed to heat an indirect domestic hot water tank. When the tank thermostat or tank sensor calls for heat, the SMART SYSTEM control will turn on the DHW pump and turn off the boiler pump (if running). If the system pump is running, it will remain on. When the DHW call for heat ends, and there is no space heating call for heat, the DHW pump will continue to run for a period of time. This pump delay is set at the factory to 30 seconds. If a shorter or longer delay is desired, the appropriate parameter in the control must be changed. See the Power-fin Service Manual for a detailed explanation of this procedure. If there is an active space heating call for heat, then the boiler pump will be turned on and the DHW pump will be turned off.

Set outlet target temperature (boiler only)

When in the DHW Mode, the control will modulate to maintain the outlet temperature to a set point. This set point is set at the factory to 180°F (82.2°C). If a different set point is desired, the appropriate parameter in the control must be changed. See the Power-fin Service Manual for a detailed explanation of this procedure.

Set tank target temperature

If a tank sensor is used, the tank set point can be adjusted by pressing either the UP or DOWN key. A menu will appear on the LCD display. Press the DOWN key to select the tank set point, and press ENTER. Use the UP and DOWN keys to adjust the set point. Press the ENTER key again to save the new set point and return to the normal display.

7 Start-up *(continued)*

Set clock

The SMART SYSTEM control has a built-in clock that it uses for its night setback feature and for logging events. This clock must be set when the appliance is installed, and anytime the appliance has been powered off for more than one month. Use the following procedure to set the clock:

1. Press and hold the MENU key (FIG. 8-1) for at least 5 seconds.
2. The display changes to ready “ENTER MENU CODE”, with four (4) zeros below it.
3. Change the zeros to match the user code (factory set at “0704”). Use the UP and DOWN keys to increment or decrement the flashing digit, and the NEXT and PREVIOUS keys to select which digit flashes.
4. Press the ENTER key.
5. The display changes to read USER CODE for a few seconds, then displays a menu.
6. Press the ENTER key.
7. Press the UP key twice to display “A3 DATE AND TIME”.
8. Press the ENTER key once.
9. The date and time are displayed as “YY:MM:DD W hh:mm”, where:
 - mm: minutes
 - hh: hour (24 hour time; e.g., 2:00 PM = 14:00)
 - W: day of the week (1 = Sunday, 2 = Monday, 3 = Tuesday, etc.,)
 - YY: year
 - MM: month
 - DD: date

NOTICE

The internal clock does not adjust for Daylight Savings Time and therefore, will require a manual adjustment.

Use the UP and DOWN keys to increment or decrement the flashing number, and the NEXT and PREVIOUS keys to select which number flashes.

10. Press the ENTER key to save the setting.
11. Press the MENU key twice to exit the Programming Mode.

Configuration of the cascade

When installed in a Cascade system, the individual controls must be programmed for cascade operation. This is accomplished by accessing the control parameters.

Input the Installer code as described in the Power-fin Service Manual. Once the control parameters have been accessed, use the DOWN arrow key to select the H Control Mode parameters. Press the ENTER key to access these parameters. Use the UP arrow key to access parameter H4 Cascade. Press the ENTER key to access this parameter. Use the DOWN arrow key to select Enable. Press the ENTER key to program this into the control. Press the EXIT key, then press the DOWN key until I Cascade is selected.

Press the ENTER key to select the parameter I1 BLR Address. Press the ENTER key to access this parameter. Each unit in the Cascade system must be programmed with its own address. The unit designated as the Leader will have an address of 0. The remaining units in the Cascade will be Members and have addresses from 1 - 7. Use the UP and DOWN arrow keys to select the appropriate address. Press the ENTER key to program this into the control.

Press the MENU key twice to exit the control parameters. Repeat this procedure for all appliances in the Cascade, designating the Leader control and the Member controls.

8 Operating information

General

How the appliance operates

The Power-fin uses a copper finned tube heat exchanger to transfer heat from the flue products to the water. An electronic control module monitors various inputs to initiate a call for heat. The blower provides both primary and secondary air to the burner and forces the flue products out of the combustion chamber and into the vent system. The control module regulates the blower speed to control the firing rate of the unit. The modulating gas valve monitors the amount of combustion air being pulled into the blower and regulates the amount of gas supplied, which then mixes with the combustion air and is supplied to the burner.

NOTICE

If an inline high gas pressure regulator is used, it MUST BE of the lockup type and be located a minimum of 10 feet from the appliance. Failure to do so may result in insufficient gas volume supplied to the appliance.

NOTICE

If a pressure drop of more than 2" water column occurs between Standby (static) Mode and Operating (dynamic) Mode, a gas volume problem exists. Contact the gas utility, gas supplier, qualified installer, or service agency to determine the necessary steps to provide the proper gas volume to the appliance.

How the control module operates

The SMART SYSTEM control module receives input from appliance sensors and external devices. The control module activates and controls the blower and gas valve to regulate heat input and switches the boiler, Domestic Hot Water (DHW), and system pumps on and off as needed. The user programs the module to meet system needs by adjusting control parameters. These parameters set operating temperatures and appliance operating modes. Boiler operation can be based on boiler outlet water temperature, boiler inlet water temperature, system supply temperature, or system return temperature, depending on the parameter setting. Water heater operation can be based on a tank sensor or a tank thermostat.

Control inputs and outputs

Enable

This input tells the boiler to provide water for space heating.

Tank thermostat

This input tells the boiler to provide water for heating a domestic hot water tank.

0 - 10V input (set point or power)

The Power-fin can be controlled by a Building Management System (BMS) using a 0 - 10 VDC signal. The control can be configured by the installer to use this signal to either control set point or firing rate.

DHW priority (boiler only)

The SMART SYSTEM control module allows connection of a DHW thermostat or tank sensor to the low voltage connection board. When the DHW thermostat or tank sensor calls for heat, the module activates the DHW pump, shuts down the boiler pump, and immediately sets the target outlet water temperature to 180°F (82.2°C). This provides automatic priority heat allocation to the indirect water heater for maximum response and recovery. The DHW pump continues for 30 seconds after the heating cycle to deliver the most possible heat.

DHW / SH (space heating) cycling (boiler only)

If an indirect DHW call for heat is received while a space heating call is in progress, the control will start the DHW pump and shut the boiler pump off. The system pump will remain on. If the space heating call is still active while the DHW call is in operation, the control will wait for 30 minutes (time adjustable by installer) then it will switch back to the space heating demand. The control will switch back and forth until one of the heat demands end.

Programmable controlling sensor (boiler only)

The control module is programmed to use the outlet sensor as the control sensor by default. If a system supply sensor is connected, the control automatically uses it as the control sensor. The control sensor can be changed by the installer to the inlet sensor. In this case, if a system return sensor is installed, the control automatically uses it as the control sensor. If the inlet sensor is chosen as the controlling sensor, it is recommended that the system supply sensor be installed for the best system performance.

Anti-cycling (boiler only)

After the set point has been satisfied, the control will delay the next burner cycle for a set time period (time is adjustable by the installer). The time delay will be bypassed if the system return temperature drops too far during the delay.

Boiler, system, and DHW pump control

When a space heating call for heat starts and no DHW call is on, the system and boiler pumps are turned on. As long as the space heating call for heat is on, the system pump will remain on. If a DHW call for heat is on, the boiler pump will wait to turn on until just before the DHW pump turns off. After the space heating call for heat ends, both pumps will run for an additional period of time.

When a DHW call for heat starts, the DHW pump is turned on. If a space heating call for heat was on, the boiler pump will turn off a few seconds after the DHW pump turns on.

8 Operating information *(continued)*

Temperature control

Modulation

The Power-fin is capable of modulating its firing rate from a minimum of 20% (M9) or 60% (B9) to a maximum of 100%. The F9 model can only fire at 100%. The firing rate is dictated by the call for heat (i.e., space heating or domestic hot water), the heating load, ramp delay (if enabled), and various other temperature limitations.

Ramp delay (boiler only)

For systems with lower flow, the SMART SYSTEM can limit the firing rate (when enabled) when a space heating call for heat starts, or when switching from a DHW call for heat to a space heating call for heat. There are six (6) limits that can be programmed, as well as six (6) time intervals corresponding to each limit. The sixth limit will also limit the firing rate for the rest of the call for heat.

Gradient limiting

If during operation of the heater the outlet water temperature is rising too quickly, the control will reduce the firing rate to its lowest setting.

Outdoor air reset (boiler only)

With the outdoor air sensor connected, the control module will calculate the set point based on the programmed reset curve. The installer can change the slope of the reset curve by several adjustable parameters. The user can limit the maximum set point for the system using the space heating set point.

Boost function (boiler only)

If outdoor air reset is active, and a space heating demand has been active continuously for a set period of time (time adjustable by installer) and there has been no DHW demands, the control may be programmed to increase the set point by a fixed number of degrees (adjustable by installer). This process will repeat until the space heating demand ends, the set point reaches the programmed set point or a maximum of 20 increases has occurred. Once the system heat demand is satisfied, the set point will revert to the value determined by the reset curve.

Night setback

The controller may be programmed to reduce the space heating (boilers) and tank (water heaters) set points during a certain time each day. A start and stop time can be programmed for each day of the week.

Flame current support

To prevent nuisance shutdowns when the boiler is firing at minimum rates, the control will increase fan speed when the flame signal drops too low.

Protection features

Outlet temperature, flue temperature, and temperature rise limiting

The outlet temperature is monitored by the boiler outlet temperature sensor. When the outlet temperature exceeds 215°F (85°C) (boilers) or 185°F (85°C) (water heaters), the unit will reduce the fan speed. If the outlet water temperature exceeds 225°F (107°C) (boilers) or 195°F (90.6°C) (water heaters) the control will shut the unit down until it cools off.

The control module monitors the flue temperature by a sensor located in the flue exhaust. If the flue temperature exceeds 400°F (204°C) the control will reduce the maximum fan speed. If the flue temperature exceeds 450°F (232°C) the control will shut the unit down. The unit will restart automatically once the flue temperature drops 100°F (56°C) and the minimum off time has expired.

The control monitors the temperature difference between the inlet and the outlet sensor. If this difference exceeds 55°F (31°C) the control will reduce the fan speed. If the temperature difference exceeds 65°F (36°C) the control will shut the unit down. The unit will restart automatically once the temperature difference has dropped 10°F (6°C) and the minimum off time has expired.

Freeze protection

DO NOT install the appliance in a room likely to freeze.

The following integral feature of the SMART SYSTEM control module provides some protection for the appliance only -- not for the system.

- The SMART SYSTEM control module provides freeze-up protection as follows when the appliance water temperature drops below 45°F (7.2°C):
- Below 45°F (7.2°C), the appliance and system pumps operate constantly.
- Below 37°F (2.7°C), the appliance turns on.
- Appliance and pumps turn off if appliance water temperature rises above 45°F (7.2°C).

CAUTION

This feature of the SMART SYSTEM control module does not eliminate the possibility of freezing. The installer must still use recognized design, installation and maintenance practice to prevent freeze potential for the appliance and system.

High limit operations

When outlet temperature exceeds 230°F (110°C) (boilers) or 200°F (93°C) (water heaters), high limit action occurs. The appliance shuts down until the outlet water cools down and the RESET button on the Operator Interface is pressed.

8 Operating information

Low water cutoff protection

1. The SMART SYSTEM control module uses temperature sensing of both inlet and outlet areas of the heat exchanger. If the flow rate is too low or the outlet temperature too high, the control module modulates and shuts the appliance down. This along with the flow switch, ensures appliance shutdown in the event of low water or low flow conditions.
2. Some codes and jurisdiction may accept these integral features of the control in lieu of requiring an additional limit control or low water cutoff. Consult local jurisdiction to determine. Contact manufacturer for low water cutoff kit availability.

Monitor external limits

Connections are provided on the connection board for external limits such as a louver proving switch. The SMART SYSTEM will shut off the burner and inhibit relighting whenever any of these external limits open.

Run-time and alarm outputs

The appliance provides dry contacts for indicating when the appliance is running, and when it is unable to operate.

Run-time and cycle counting

The control uses two timers to monitor the total hours of burner operation. One timer monitors the time the appliance is firing under 50% of rate. The other timer monitors the time the appliance is firing over 50% rate.

The control uses four (4) ignition counters to monitor the amount of appliance cycles. The first counter counts all ignitions of the control. The second counter counts only ignition attempts that have failed. The third and fourth counters are the same as the first and second respectively, but can be reset by the installer.

Service reminder

The control can be programmed for service reminder notification. This notification will become active when either a set time frame has expired, or a set amount of running hours or cycles has expired (all adjustable by the installer). The display will alternate the standard text on the display screen with Service Due every 5 seconds. The service reminder notification can be reset by the installer.

Error logging

The control will hold in memory the last 10 error codes as well as the last 10 turn-off functions. The date and time of the occurrence will be recorded as well. Only the 10 most current occurrences will be held in memory.

Boiler temperature regulation

Operating temperature (target)

The SMART SYSTEM control module senses water temperature and regulates appliance firing and firing rate to achieve a target temperature. The target temperature can be set between 70°F (21°C) and 220°F (104°C) (boilers) or between 60°F (16°C) and 190°F (88°C) (water heaters).

- Target temperature is fixed when the outdoor sensor is not installed (boilers).
- Target temperature is calculated as described under “Outdoor Air Reset Operation” and “Boost Function” when the outdoor sensor is connected (boilers).

Outdoor reset operation, if used (boilers only)

Target temperature with outdoor reset

This feature improves the system’s efficiency as the outdoor temperature warms up.

See the Power-fin Service Manual to change the settings.

Reset curve

The reset curve looks at outdoor air temperature and adjusts the set point.

Cascade

When multiple appliances are installed, they can be wired together in a cascade sequence. A maximum of eight appliances can be controlled from a single control. In this application one appliance would be designated as the Leader control and all others would be designated as Member controls. The set point or firing rate can be controlled by the 0 - 10V input as well.

Once the Leader appliance receives a call for heat from a BMS, tank sensor, or external thermostat, the control will determine what the set point will be. A fixed temperature set point can be programmed into the control. See page 54 of this manual to program the set point.

On boilers, if the water temperature at the system sensor is less than the set point + the turn-off offset - the off-on differential, then the control will initiate a call for heat on the Cascade (see the Power-fin Service Manual for an explanation of the offset and differential). The Leader will energize the lead appliance on the Cascade. For a new startup this will be the Leader appliance.

On water heaters, if the water temperature at the tank sensor is less than the tank set point - the off differential, then the control will initiate a call for heat on the Cascade.

8 Operating information *(continued)*

The appliance will fire at its ignition speed and will then modulate its firing rate to maintain the set point (M9 and B9 only). If the first appliance reaches 100% of its firing rate, the Leader will calculate at what point the second appliance could fire at its minimum firing rate. At this point, the Leader will fire the second appliance on the Cascade. For a new startup, this would be the first Member appliance. The appliance will fire at its ignition speed and will then modulate its firing rate to maintain the set point (M9 and B9 only).

If the set point still cannot be met, the Leader will continue firing more Members until either the heat demand is met or all appliances on the Cascade are firing. As the heat demand decreases, the last appliance on will modulate down to its minimum firing rate (M9 and B9 only). Once the demand for that appliance is 0% it will shut down. As the heat demand decreases further, the second to last appliance will modulate down and shut off. This will continue until the demand is satisfied and all appliances are shut off.

Sequence of the cascade

To equalize the run time of all appliances on the Cascade, the firing sequence will automatically be changed at set intervals.

For the first 24 hours after initializing the Cascade, the sequence will be changed every hour. After that the sequence will be changed once every 24 hours. The switching on/off sequence will be as follows:

DAY	SWITCHING ON SEQUENCE
Day 1	L-M1-M2-M3-M4-M5-M6-M7
Day 1 + 1 hour	M1-M2-M3-M4-M5-M6-M7-L
Day 1 + 2 hour	M2-M3-M4-M5-M6-M7-L-M1

DHW, Night Setback, and Ramp Delay operation with cascade

For indirect DHW operation any boiler(s) in the Cascade can be selected to provide heat for a DHW call. Select a boiler to be designated as the DHW boiler. Connect the tank thermostat or tank sensor to the corresponding terminals on the low voltage connection board. When the boiler receives a DHW call, the Leader control will take that boiler out of the Cascade sequence. If another boiler is available, the Leader will start it up to take its place.

The DHW boiler will adjust its set point to the programmed outlet set point and will adjust its firing rate to maintain this (M9 and B9 only). Once the DHW call has been satisfied, the Leader control will place that boiler back into the Cascade sequence.

Switching of the boiler between DHW operation and SH operation when there is a call for both does not occur. The boiler will provide heat for the DHW demand until it is satisfied.

Night Setback operation of the boilers or water heaters within the Cascade is available. Programming of the Night Setback will be done through the Leader boiler. Refer to the Power-fin Service Manual for information regarding Night Setback.

Ramp Delay operation of the boilers as described in the Power-fin Service Manual is not active when the boilers are part of a Cascade system.

8 Operating information

Sequence of operation

OPERATION	DISPLAY
1. The manual reset high limit must be closed before any action will take place.	HTR: Standby OUT: 123.8F (129)
2. Upon a call for heat the control turns on the appropriate pumps (system and boiler pumps for space heating; DHW pump for DHW call). The flow switch and low water cutoff (if equipped) must close.	HTR: Standby OUT: 123.8F (129)
3. <ul style="list-style-type: none"> • If the unit is equipped with a proof of closure valve, the proof of closure switch must be closed. The proof of closure valve is then energized. The gas pressure switch(es) (if equipped) must close. • If the contact for the louvers is closed, the louver proving, blocked drain switch, and auto reset high limit (water heater only) inputs must close. • If the air pressure switch is open, the prepurge cycle then begins by starting the combustion blower. Once started, the air pressure switch must close. 	HTR: Standby OUT: 123.8F (129)
4. After the 10 second prepurge, the blower slows down and the hot surface igniter (HSI) is energized. The HSI is heated for at least 15 seconds.	HTR: PREPURGE OUT: 123.9F (129)
5. Once the HSI is hot, the trial for ignition begins with the opening of the gas valve.	HTR: IGNITION OUT: 123.9F (129)
6. If the SMART SYSTEM control does not sense flame within 7 seconds of the opening of the gas valve, then it will lock out.	HTR: POSTPURGE, LOCKOUT OUT: 123.9F (129)
7. If the SMART SYSTEM control senses flame within 7 seconds, it will fire the burner to maintain the set point. On B9 and M9 models, the firing rate will modulate as required to hold the actual temperature at the set point. If the boiler lights due to a space heating call for heat, and the ramp delay function is active (default is disabled), the modulation will be held to a series of increasing limits after the burner has lit.	HTR: SH 20% RATE OUT: 124.8F (129)
8. If the space heating call for heat is active, and the DHW thermostat closes, the control will turn on the DHW pump, wait 2 seconds, and then turn off the boiler pump. This will divert the hot water away from the heating zone(s) and send it to the DHW tank instead. The control will then modulate (B9 and M9 models only) to maintain the outlet temperature to the DHW boiler set point.	HTR: DHW 85% RATE OUT: 177.8 (180)

8 Operating information *(continued)*

OPERATION	DISPLAY
<p>9. If the DHW thermostat remains on for more than 30 minutes, and the space heating call for heat is also on, then the control will turn on the boiler pump, turn off the DHW pump after 2 seconds, and resume firing based on the space heating set point. As long as both the space heating and DHW calls for heat remain active, the control will switch back and forth between the two modes until one of them is satisfied.</p>	<p>HTR: SH 41% RATE OUT: 123.0F (129)</p>
<p>10. Once both calls for heat are satisfied, the control will turn off the burner. The blower will remain on for the 30 second postpurge cycle. Any pumps that are running will continue to run for their respective pump delay times, then turn off.</p>	<p>HTR: POSTPURGE OUT: 127.4F (129)</p>
<p>11. Boiler pump off, system pump continues its delay if longer.</p>	<p>HTR: Standby OUT: 124.7F (129)</p>
<p>12. System pump off.</p>	<p>HTR: Standby OUT: 122.9F (129)</p>

8 Operating information

SMART SYSTEM™ Power-fin control module

Use the control panel (FIG. 8-1) to set temperatures, operating conditions, and monitor appliance operation.

Figure 8-1_Control Panel - Operator Interface

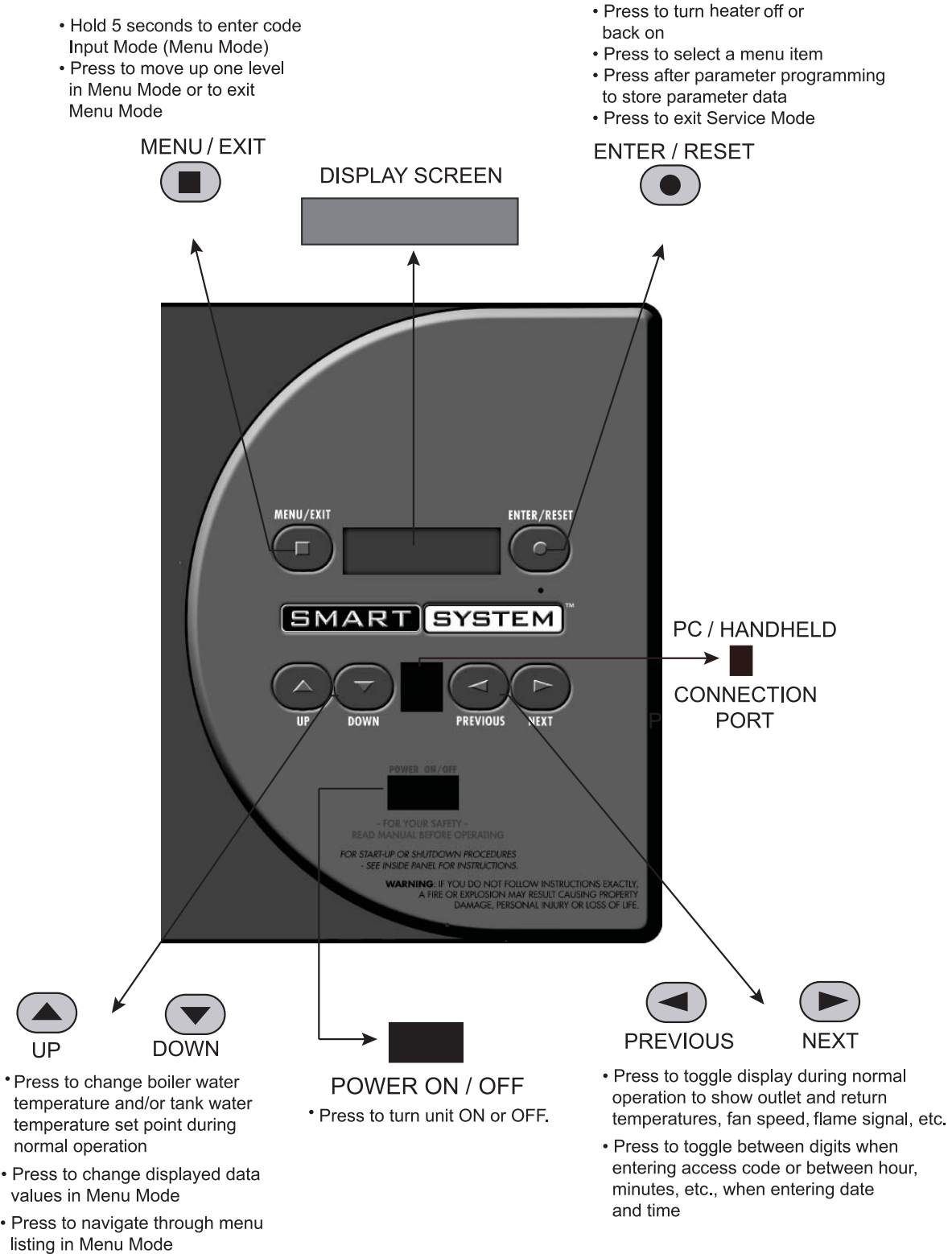

8 Operating information *(continued)*

Access modes

User

The user can adjust the space heating target temperature and the tank target temperature (if a tank sensor is used) by using the UP and DOWN buttons (FIG. 8-1) at any time during normal operation. By entering the USER code (0704), the user can also change temperature units, time and date, and night setback settings. In User Mode, the following parameters can be viewed but not changed:

- Boiler outlet water target temperature in DHW Mode
- Appliance model number
- Software version
- Total operating hours
- Total cycles

Installer

Most parameters are available only to the installer, accessible only by entering the installer access code, see the Power-fin Service Manual.

Saving parameters *(reference the Parameter Table in the Power-fin Service Manual)*

To save parameters and exit programming:

Press the ENTER/RESET button, then the MENU/EXIT button 3 times.

To keep parameter settings only for a current operating cycle:

Press the MENU/EXIT button 3 times after making all desired parameter changes.

To enter a parameter and continue programming:

Press the MENU/EXIT button 1 time to return to the parameter listings; press again to return to the menu listings. Remember to press the ENTER/RESET button when finished programming in order to save the changes made.

See the Power-fin Service Manual for a detailed description of parameters and access modes.

8 Operating information

Status display screens

Status Display Screens		
By using the Previous/Next (◀, ▶) arrow keys on the SMART SYSTEM display panel, you can navigate through the nine (9) display screens. Each screen will contain two (2) viewable items. The following is a description of the individual items and what they can display:		
Screen	Display shows:	Description
#1	HTR: OFF	The unit has been turned OFF by the Enter/Reset button on the SMART SYSTEM display panel.
	Standby	The unit has not received a call for heat from a remote thermostat nor has it received a call for heat from a DHW thermostat.
	Set Point Met	The unit has met the water temperature set point, but is still receiving a call for heat from either a remote thermostat, a DHW thermostat, or a BMS.
	Prepurge	The unit has initiated the 10 second purge and 15 second HSI warm-up periods on a call for heat.
	Ignition	The unit has begun a 5 second trial for ignition.
	SH***% Rate DHW***% Rate	The unit has fired and is running at the displayed percentage.
	Postpurge	The call for heat has been satisfied and the unit runs the fan for an additional 10 seconds to clear the combustion chamber and vent system of residual flue products.
	Service	The unit has been placed in a temporary mode that will allow the unit to fire for the purpose of combustion analysis.
	OUT: ***F(***)	When the outlet sensor has been selected as the control sensor (default), the control will display the outlet temperature as well as the set point in parenthesis.
	***F	If the outlet sensor has not been selected as the control sensor or a system supply sensor is connected, only the outlet temperature will be displayed.
	Open	The control does not detect the outlet sensor.
Shorted	The outlet sensor wires or the sensor itself has become shorted.	
Press the Next ▶ arrow key on the SMART SYSTEM display to access Screen #2.		
#2	IN: ***F	If the inlet sensor has not been selected as the control sensor or a system return sensor is installed, only the inlet temperature will be displayed.
	F ()	When the inlet sensor has been selected as the control sensor, the control will display the inlet temperature as well as the set point in parenthesis.
	Open	The control does not detect the inlet sensor.
	Shorted	The inlet sensor wires or the sensor itself has become shorted.
	RISE: ***F	The difference between the inlet temperature and the outlet temperature.
Press the Next ▶ arrow key on the SMART SYSTEM display to access Screen #3.		

8 Operating information *(continued)*

Status Display Screens *(cont'd)*

By using the Previous/Next (◀, ▶) arrow keys on the SMART SYSTEM display panel, you can navigate through the nine (9) display screens. Each screen will contain two (2) viewable items. The following is a description of the individual items and what they can display:

Screen	Display shows:	Description
#3	SYS: ***F	If the system sensor has not been selected as the control sensor, only the system temperature will be displayed.
	F ()	When the system sensor has been selected as the control sensor, the control will display the system temperature as well as the set point in parenthesis.
	Open	The control does not detect the system sensor.
	Shorted	The system sensor wires or the sensor itself has become grounded.
	OUTDOOR: ***F	The control will display the outdoor air temperature as sensed by the outdoor air sensor.
	Open	The control does not detect the outdoor air sensor.
	Shorted	The outdoor air sensor wires or the sensor itself has become grounded.
Press the Next ▶ arrow key on the SMART SYSTEM display to access Screen #4.		
#4	SYSRT: ***	The control will display the system return temperature if the system return sensor is connected. If not connected, the display will skip this screen and display screen #5.
	VALVE: ***%	The control will display the position of the 3-way valve; 100% indicates that no outlet water is being bypassed into the inlet.
Press the Next ▶ arrow key on the SMART SYSTEM display to access Screen #5.		
#5	FLUE: ***F	The control will display the flue temperature.
	Open	The control does not detect the flue sensor.
	Shorted	The flue sensor wires or the sensor itself has become grounded.
	TANK: ***F	The control will display the temperature.
	Open	The control does not detect the auxiliary sensor.
	Shorted	The auxiliary sensor wires or the sensor itself has become grounded.
Press the Next ▶ arrow key on the SMART SYSTEM display to access Screen #6.		
#6	FAN SPD: ****RPM	The control will display the actual fan motor RPM.
	FLAME SIG: **. *uA	The control will display the flame signal in dc microamps.
Press the Next ▶ arrow key on the SMART SYSTEM display to access Screen #7.		

8 Operating information

Status Display Screens (cont'd)

By using the Previous/Next (◀, ▶) arrow keys on the SMART SYSTEM display panel, you can navigate through the nine (9) display screens. Each screen will contain two (2) viewable items. The following is a description of the individual items and what they can display:

Screen	Display shows:	Description
#7	SH CFH: OFF	The control has not received a call for heat from a SH remote thermostat.
	ON	The control has received a call for heat from a SH remote thermostat.
	DHW CFH: OFF	The control has not received a call for heat from a tank sensor or tank thermostat.
	ON	The control has received a call for heat from a tank sensor or tank thermostat.
Press the Next ▶ arrow key on the SMART SYSTEM display to access Screen #8.		
#8	DHW PUMP: OFF	The control has not received a DHW call for heat and has not powered the DHW pump.
	ON	The control has received a DHW call for heat and has powered the DHW pump.
	Delay	The DHW call for heat has been satisfied and the DHW pump is running for a fixed time to remove any residual heat.
	0-10V IN: **.VDC	The control will display a 0-10 VDC signal received from a Building Management System (BMS) connected to the unit.
Press the Next ▶ arrow key on the SMART SYSTEM display to access Screen #9.		
#9	SYS PUMP: OFF	The control has not received a call for heat from a remote thermostat and has not powered the system pump.
	ON	The control has received a call for heat from a remote thermostat and has powered the system pump.
	Delay	The system call for heat has been satisfied and the system pump is running for a fixed time to remove any residual heat.
	BLR PUMP: OFF	The control has either not received a call for heat from a remote thermostat, a remote thermostat is not connected to the unit and the water temperature has not dropped below the temperature set point of the control to initiate a call for heat, or the control has received a DHW call for heat from a DHW thermostat.
	ON	The control has received a call for heat from a remote thermostat or a remote thermostat is not connected and the water temperature has dropped below the temperature set point of the control to initiate a call for heat.
	Delay	The call for heat has been satisfied and the boiler pump is running for a fixed time to remove any residual heat.
Press the Next ▶ arrow key on the SMART SYSTEM display to access Screen #10.		

8 Operating information *(continued)*

Status Display Screens *(cont'd)*

Operation of the cascade

The boiler designated as the Leader will have two additional display screens that can be viewed. These screens will provide information regarding the operation of the Cascade. Each screen will contain two viewable items. The following is a description of the individual items and what they can display:

Screen	Display shows:	Description
#10	Cas: Off	The Leader control has been turned off by the Enter/Reset button on the Smart System display.
	Cas: Standby	The Leader boiler has not received a call for heat from a remote thermostat.
	Cas: ***F(***)	The Cascade is now active. The system temperature will be displayed. The Cascade set point will be displayed in parenthesis.
	Cas: Setpoint Met	The Cascade has met the water temperature set point, but is still receiving a call for heat from a remote thermostat.
	Cas: No Members	The Leader control could not detect any Member controls to participate in the Cascade.
	Cas: S6 Not Present	The system sensor is not connected to the Leader boiler.
	PMP: Off	The Leader control has not received a call for heat from a remote thermostat and has not powered the system pump.
	PMP: On	The Leader control has received a call for heat from a remote thermostat and has powered the system pump.
	PMP: Delay	The system call for heat has been satisfied and the system pump is running for a fixed time to remove any residual heat.

Press the Next ► arrow key on the SMART SYSTEM display to access Screen #11.

#11	Cas PWR: ***% ***%	The first percentage shows the firing rate that is being sent to the last boiler called on. The second percentage shows the total power available to the Cascade.
	Present: 01234567 Example: Present: 23----d1	Shows the number of boilers connected to the Cascade. The Leader is designated as 0. Members will be designated 1 - 7. If a “-“ is used in place of a number, that boiler is either not connected, or in a lockout mode and not available for the Cascade. If a “d” is used in place of a number, that boiler is handling a DHW demand and is not available for the Cascade. If the number is flashing, then that boiler is providing heat to the Cascade. As the lead boiler is changed from day to day, that boiler’s address will be shown first in the string of numbers. In the example, boilers 0 - 3 are present, boiler 2 is the lead boiler, and boiler 0 is heating an indirect DHW tank.

Press the Next ► arrow key on the SMART SYSTEM display to roll back to Screen #1. At any point if you wish to access an earlier screen, press the Previous ◀ arrow key on the SMART SYSTEM display.

9 Domestic water heaters

This section applies only to those appliances used to supply domestic hot water, installed with a storage tank(s). A circulating pump **MUST** be installed in the piping assembly to the storage tank and valves used to control water velocity through the appliance. Proper water velocity is important for correct operation of your water heater.

This section contains specific instructions for those appliances used to supply domestic hot water. All warnings, cautions, notes and instructions in the general installation and operation sections apply to these instructions. Water heaters are designed for installation with a storage tank. The operation of the circulating pump, proper sizing of the piping between the tank and heater and the control of water velocity, as explained in this section, are important for correct operation of your water heater.

NOTICE

To ensure proper velocity through the heat exchanger, it is necessary to regulate the temperature rise across the heat exchanger from inlet to outlet. This must be done on initial installation and periodically rechecked. With the correct temperature rise across the heat exchanger when the water heater is firing at 100% of rated input, you may be assured of the proper velocity in the tubes. This will yield long life and economical operation from your water heater.

Excessive lime/scale build-up in the heat exchanger tubes is a result of restricted flow and too little velocity in the tubes. Excessive pitting or erosion in the tube is caused by high water flow and too much velocity through the tubes. Care should be taken to measure temperature rise and maintain velocity as follows:

Initial set-up of maximum water flow

On initial start-up of the Power-fin the maximum water flow through the heat exchanger must be manually set before normal operation begins.

TABLE 9A

MAXIMUM WATER FLOW

⚠ CAUTION: The maximum flow rate through a Power-fin water heater with a copper heat exchanger must be set to provide and not exceed the following flow:

Model	Maximum Flow
502, 752, 1002, and 1302	75 GPM
1501 - 1701 - 2001	90 GPM

If higher flow rates are required through the water heater, an optional Cupro Nickel heat exchanger is available. Consult the factory for specific application requirements.

The heat exchanger is capable of operating within the design flow rates required for the water heater, storage tank(s), and connecting piping. Erosion of the finned copper tubes may occur if the flow rate exceeds the maximum allowable flow rate through the water heater. The maximum flow rate through the water heater must be adjusted. Maximum flow on Models 502 - 1302 is 75 GPM and 90 GPM on Models 1501 - 2001. Flow rate can be determined by measuring the temperature rise through the water heater when it is firing at full rate input.

TABLE - 9B
TEMPERATURE RISE AT FULL RATE FIRE
75 AND 90 GPM FLOW

Model	Temperature Rise
502	11°F (6.1°C)
752	17°F (9.4°C)
1002	23°F (12.8°C)
1302	30°F (16.7°C)
1501	28°F (15.6°C)
1701	32°F (17.8°C)
2001	38°F (21.1°C)

1. The pump must run continuously when the burner is firing.
2. With the pump running and the burner in the water heater in the off cycle, the inlet water temperature and outlet water temperature readings on the Operator Interface should read approximately the same temperatures. Water Temperature Rise on the Operator Interface should read near zero.
3. Turn the water heater on and allow time for the temperature to stabilize. The Service Mode can be used to force the water heater to run at full fire. See the Power-fin Service Manual for a detailed explanation of the Service Mode. Check the water temperature rise in the Operator Interface when the burner is firing at 100% of rated input.
4. Compare the water temperature rise in the Operator Interface with the required temperature rise. Should adjustment be needed, proceed as follows.

9 Domestic water heaters *(continued)*

If the temperature rise is too high, the water velocity is too low, adjust as follows:

1. Check for restrictions in the outlet of the water heater.
2. Be sure all valves are open between the water heater and the storage tank. Ensure that all ball valves are fully ported.
3. Check the pump to be sure it is running properly and that the pump motor is running in the proper direction.
4. Check diameter and length of the piping between the storage tank and water heater against the head capacity of the circulating pump.
5. Be sure the pipes between the water heater and storage tank are not less than 2 1/2 inch (63.5mm) diameter. To increase flow and decrease temperature rise, increase the piping to 3 inch (76.2mm) diameter to decrease head loss in the piping to the storage tank.
6. Common manifold piping for multiple unit installations will require larger minimum pipe sizes and tank circulating tappings to ensure proper flow.

If the temperature rise is too low, the water velocity is too high, adjust as follows:

1. Temperature rise can be increased by slowly closing the field-installed ball valve in the outlet piping from the water heater to the storage tank to achieve the proper temperature rise.
2. Sustained high water velocity and low temperature rise may result in pitting or erosion of the copper tubes in the heat exchanger. This is a non-warrantable failure. Temperature rise must be properly adjusted to achieve the specified flow rate.
3. Once temperature rise has been properly set, return to normal operation.

⚠ CAUTION

Temperature rise cannot be adjusted when the burner is firing at less than 100% of rated input.

Water chemistry

NOTICE

Water temperature rise and maximum flow data is based on heating potable water with a hardness of 5 to 25 grains per gallon and total dissolved solids not exceeding 350 ppm.

The required temperature rise and the standard circulating pump are sized based on the heating of potable water with a hardness of 5 to 25 grains per gallon and a total dissolved solids not exceeding 350 ppm. Consult the manufacturer when heating potable water exceeding these specifications. Heating of high hardness and/or high total dissolved solids water may require a larger circulating pump, an optional Cupro Nickel heat exchanger and a revised temperature rise specification based on the water chemistry of the water to be heated. Water with a hardness of less than 5 grains per gallon will usually have a pH which can be aggressive and corrosive causing non-warrantable damage to the heater, pump, and associated piping. Corrosion due to water chemistry generally shows up first in the hot water system because heated water increases the rate of corrosive chemical reactions.

9 Domestic water heaters

Figure 9-1_Typical Water Heater Piping with Storage Tank

COMMON MANIFOLD SIZE (Min.) Models: 502, 752, 1002, & 1302		
Number of Units	GPM	Diameter (in.)
1	75	2 1/2

COMMON MANIFOLD SIZE (Min.) Models: 1501, 1701, & 2001		
Number of Units	GPM	Diameter (in.)
1	90	2 1/2

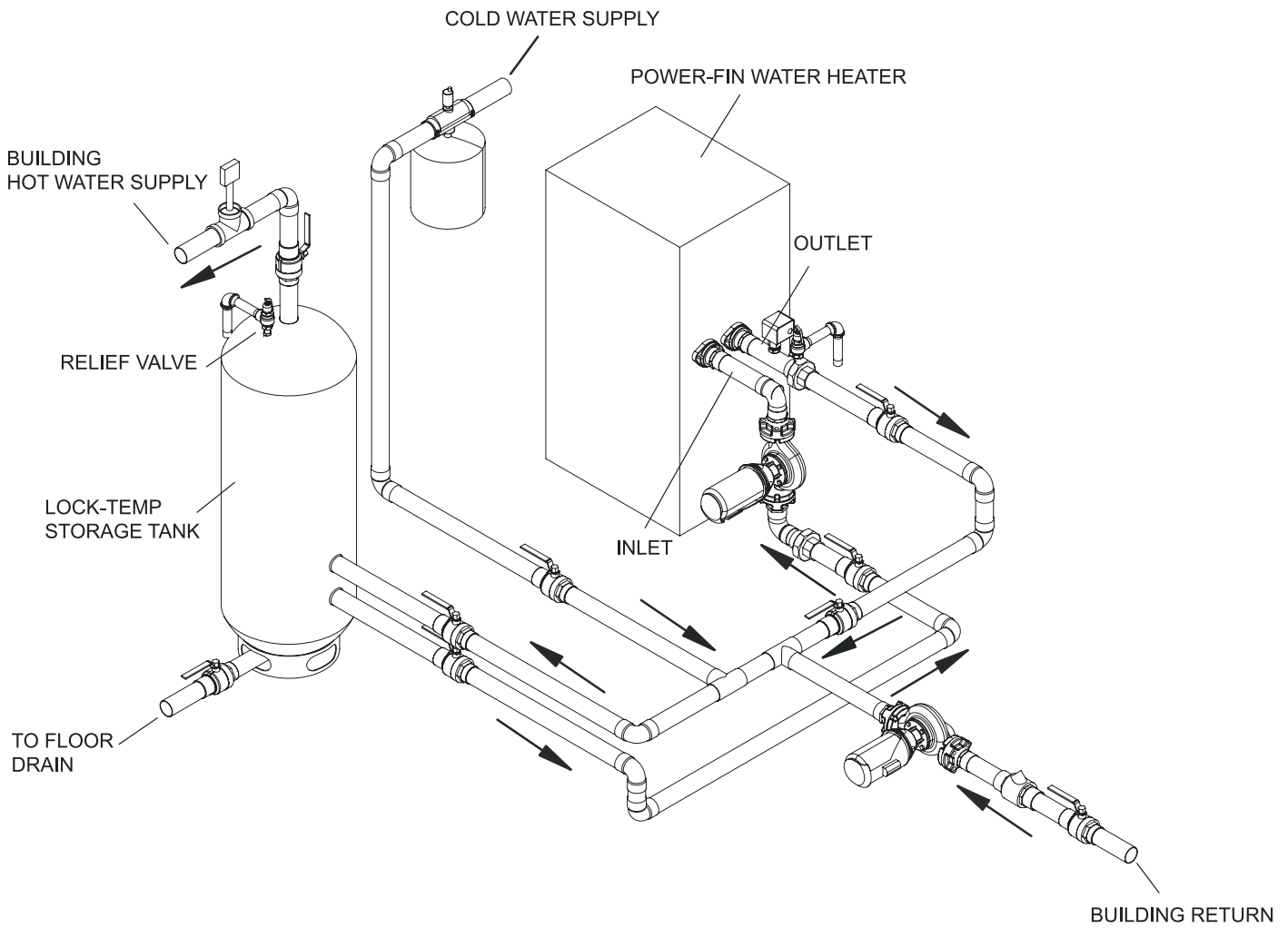

9 Domestic water heaters *(continued)*

Figure 9-2_Single Water Heater Piping with Two Storage Tanks

COMMON MANIFOLD SIZE (Min.) Models: 502, 752, 1002, & 1302		
Number of Units	GPM	Diameter (in.)
1	75	2 1/2

COMMON MANIFOLD SIZE (Min.) Models: 1501, 1701, & 2001		
Number of Units	GPM	Diameter (in.)
1	90	2 1/2

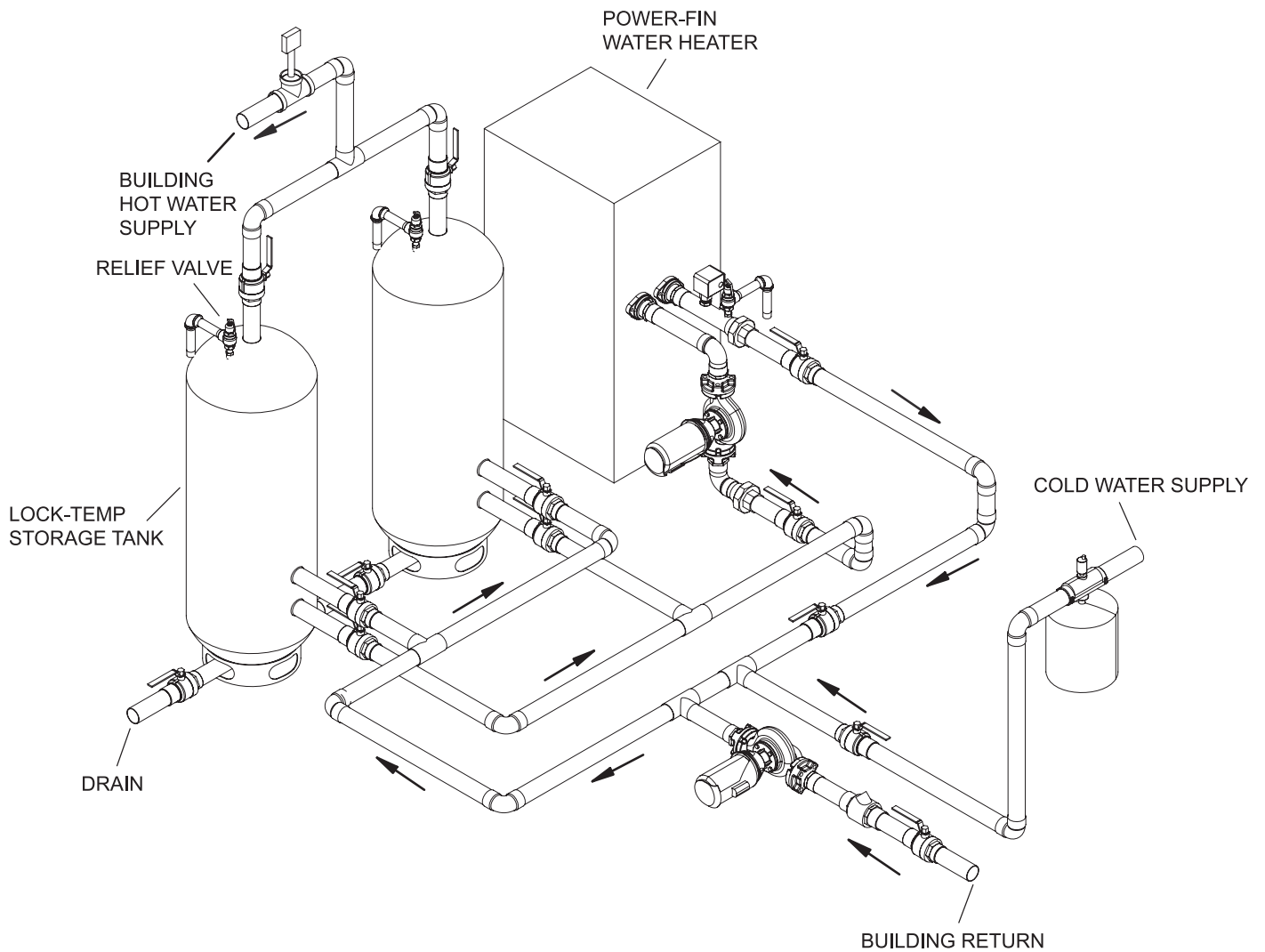

9 Domestic water heaters

Figure 9-3_Multiple Water Heater Piping with a Single Storage Tank

COMMON MANIFOLD SIZE (Min.) Models: 502, 752, 1002, & 1302		
Number of Units	GPM	Diameter (in.)
2	150	3 1/2
3	225	4
4	300	5
5	375	6
6	450	6
7	525	6
8	600	7

COMMON MANIFOLD SIZE (Min.) Models: 1501, 1701, & 2001		
Number of Units	GPM	Diameter (in.)
2	180	4
3	270	5
4	360	6
5	450	6
6	540	6
7	630	7
8	720	7

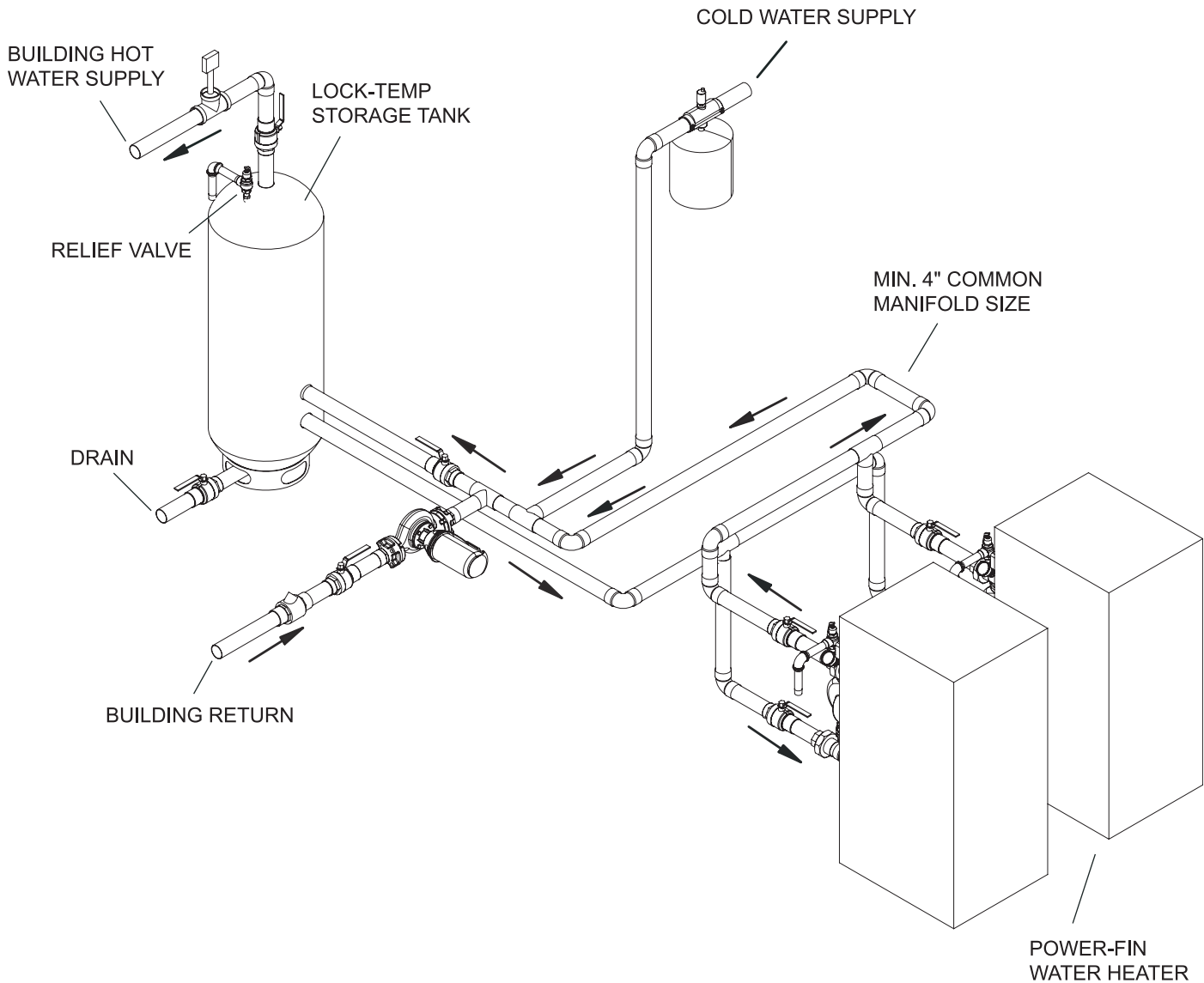

9 Domestic water heaters *(continued)*

Figure 9-4_Multiple Water Heater Piping with Multiple Storage Tanks

COMMON MANIFOLD SIZE (Min.) Models: 502, 752, 1002, & 1302		
Number of Units	GPM	Diameter (in.)
2	150	3 1/2
3	225	4
4	300	5
5	375	6
6	450	6
7	525	6
8	600	7

COMMON MANIFOLD SIZE (Min.) Models: 1501, 1701, & 2001		
Number of Units	GPM	Diameter (in.)
2	180	4
3	270	5
4	360	6
5	450	6
6	540	6
7	630	7
8	720	7

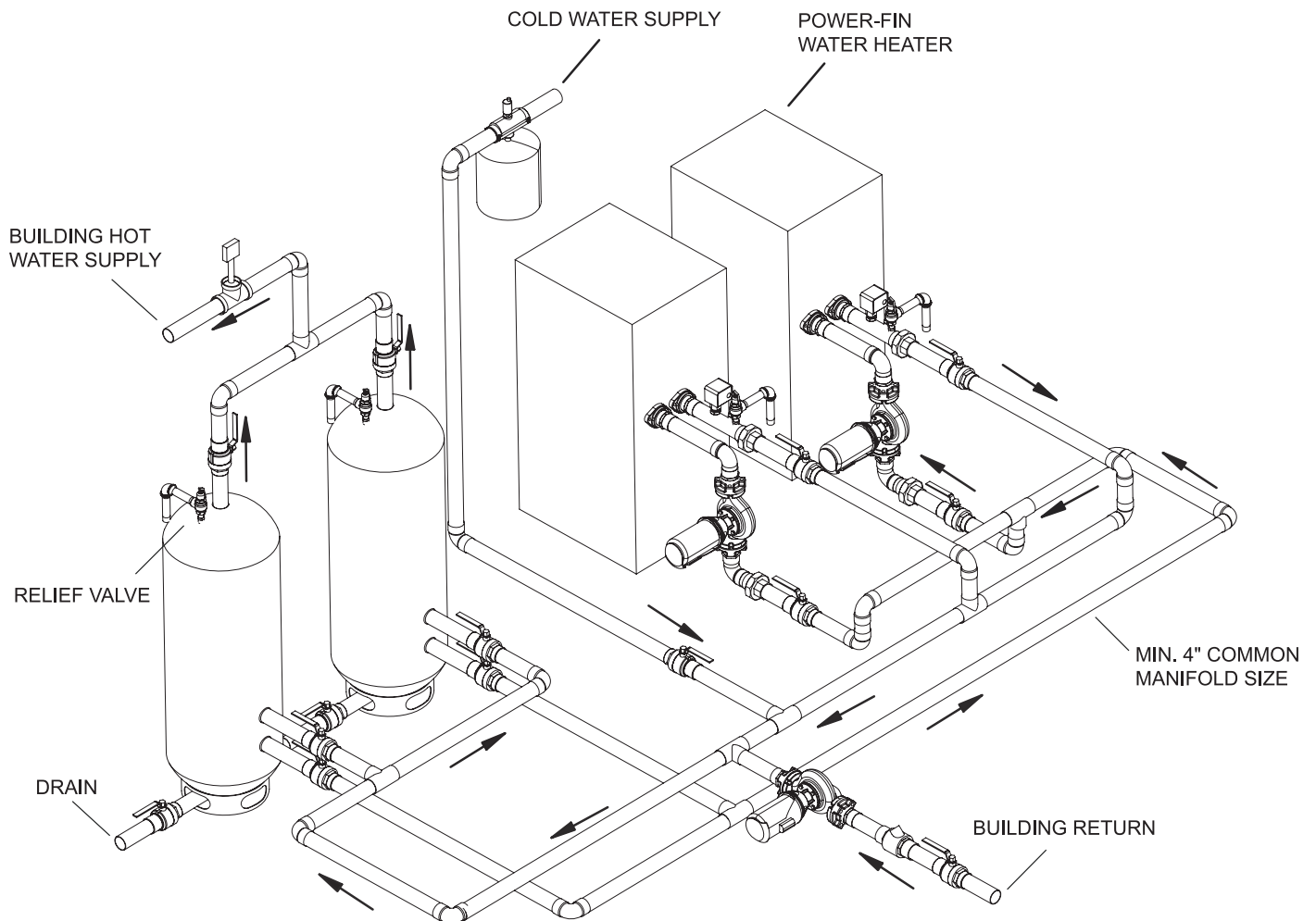

9 Domestic water heaters

TABLE 9C COMMON WATER MANIFOLD SIZE FOR MULTIPLE WATER HEATER INSTALLATIONS		
Pipe sizing chart provides minimum pipe size for common manifold piping to ensure adequate flow.		
Number of Water Heaters	Common Manifold Size (Min.) Models	
	502 - 1302	1501 - 2001
1	2 1/2"	2 1/2"
2	3 1/2"	4"
3	4"	5"
4	5"	6"
5	6"	6"
6	6"	6"
7	6"	7"
8	7"	7"

Pump operation

1. The water heater must have a properly sized circulating pump. This pump is sized to circulate water between the heater and the storage tank only.
2. The pump is sized to the heater input and water chemistry specifications noted in the *Water Chemistry section* on page 69.
3. The diameter and length of the piping installed between the storage tank(s) and water heater must be properly sized based on the capacity of the circulating pump.
4. The pump must run continuously when the water heater is energized. This is the standard operating system for a water heater.

An intermittent pump control function with an all bronze pump is installed as standard equipment on all water heater systems. The pump will operate only while there is a "Call for Heat" and for a timed period after the water temperature set point is satisfied to remove any residual heat from the combustion chamber.

5. Lubricate pump to manufacturer's recommendations. Pump damage due to inadequate lubrication is non-warrantable.

The tank sensor must be installed in the tapping provided in the lower 25% of the storage tank to achieve proper operation. As shipped from the factory, the tank sensor is in the literature package shipped with the unit. Placing the sensor in the tapping provided on the storage tank will improve temperature response and prevent short cycles of operation.

The standard circulating pump on this water heater is sized based on installation of a single storage tank and heater in close proximity. If the number of fittings and straight pipe exceeds the specified maximum equivalent number of straight feet for a specified diameter of pipe, non-warrantable operational problems may be experienced.

500,000 - 1,300,000 Btu/hr Models
1/2 HP, 120 VAC, 9.8 Amps

1,500,000 - 2,000,000 Btu/hr Models
3/4 HP, 120 VAC, 8.8 Amp

The standard pump selection is based on the following pipe and fittings from the water heater to the storage tank:

- 6 - 90° elbows
- 2 - ball valves
- 2 - unions
- 1 - cold water tee

Not more than 45 feet of straight pipe.

For every elbow and tee in excess of those shown above, DEDUCT 6.5 FEET from the maximum allowable straight pipe in the heater to tank circulating loop.

TABLE 9D MINIMUM PUMP PERFORMANCE		
Based on heating potable water with a hardness of 5 to 25 grains per gallon and total dissolved solids not exceeding 350 ppm. See <i>Water Chemistry section</i> on page 69.		
Model	GPM	Ft. Hd.
502 - 752 - 1002 - 1302	75	15
1501 - 1701 - 2001	90	15

When installing multiple water heaters and/or multiple storage tanks, the diameter of the inter-connecting pipe and all fittings must be increased. An increase in pipe diameter will decrease head loss in the system piping and ensure proper flow. Proper pipe size between the heater and storage tank **MUST** be maintained to ensure that the standard pump supplied on the water heater will maintain desired flow.

Heat exchanger

This is a highly sophisticated heat exchanger designed to carry water in such a way that it generates a scouring action which keeps all interior surfaces free from build-up of impurities. The straight-line, four pass design of the copper finned tubes send water into the headers at a properly rated velocity. The configuration of the headers, in turn, creates a high degree of turbulence which is sufficient to keep all contaminants in suspension. This "scouring action" provides greater cost savings for owners. Tubes are always able to transfer heat at peak efficiency. Every surface within this water containing section is of a non-ferrous material, providing clear, clean, rust-free hot water. Straight copper tubes-finned on the outside for maximum heat transfer and glass lined, cast iron, one piece, cored headers make up an entirely rust-proof unit. On all models, header inspection plugs in the heat exchanger can be removed for field inspection and cleaning of copper tubes. The heat exchanger may be removed from the unit.

9 Domestic water heaters *(continued)*

Thermostat adjustment procedure

1. Press the UP or DOWN key to view the set point setting.
2. Press either the UP or DOWN key to increase or decrease the displayed set point value.
3. Press the ENTER key to permanently store the new set point into the control module's memory.

Failure to press the ENTER key after changing the display value will result in the set point reverting back to its previous value after the current heat demand ends.

The control may be adjusted any time regardless of call for heat status. When pressing the UP or DOWN key to enter any new set points, the control module will immediately begin controlling based on the new set point.

Minimum water temperatures (domestic hot water use)

Domestic water temperatures:

This high efficiency water heater should be operated at a temperature setting high enough to prevent condensing of the products of combustion on the unit's heat exchanger or in the attached venting system. Use extreme caution when storing water at elevated temperatures. A water temperature setting maintained above the dew point of the products of gas combustion should prevent condensate formation and ensure proper performance of the venting system. The manufacturer recommends the use of a properly sized thermostatic mixing valve to supply domestic hot water at temperatures less than 140°F (60°C). Storing the water at a higher temperature and thermostatically mixing the water will increase the available quantity of mixed hot water, greatly reducing the possibility of condensate formation on the heat exchanger or in the venting system and help prevent the growth of water borne bacteria.

NOTICE

Adequate care **MUST** be taken to prevent a potential scald injury when storing water at elevated temperatures for domestic use.

Inlet water temperatures below the specified minimum recommendations can excessively cool the products of combustion resulting in condensation on the heat exchanger. Condensation on the heat exchanger can cause operational problems, bad combustion, sooting, flue gas spillage and reduced service life of the related components.

CAUTION

An appliance allowed to operate at return temperatures below the specified minimum setting may experience problems with the operating controls, safety switches, obstruction of the flue gas passages on the heat exchanger, incomplete combustion, and possible flue gas spillage. Sustained operation at lower than specified water temperatures may cause hazardous conditions that may result in personal injury or non-warrantable damage to the appliance.

The maximum temperature set point that can be programmed into the control module from the Operator Interface for water heater operation is 190°F (88°C). The control is factory pre-set at approximately 120°F (49°C). Facilities with small children or invalids may require 120°F (49°C) or a lower temperature setting to reduce risk of scald injury. Some states may require a lower temperature setting. Check with your gas supplier for local requirements governing the temperature setting. Remember, no water heating system will provide exact temperature at all times. Allow a few days of operation at this setting to determine the correct temperature setting consistent with your needs.

NOTICE

1. This water heater, when set at the lower temperature setting, is not capable of producing hot water of sufficient temperature for sanitizing purposes.

2. Higher stored water temperature increases the ability of the water heater to supply desired quantities of hot water, however remember --

CAUTION

Hotter water increases the risk of scald injury.

9 Domestic water heaters

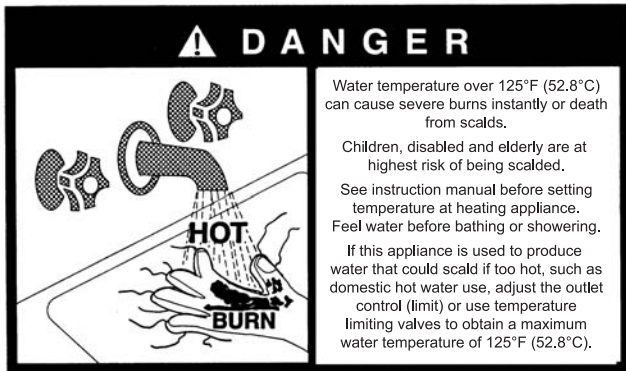

Figure 9-5_Danger Warning

Location of Cold Water Supply Piping Connections

Incorrect piping of the cold water supply to the system may result in excessive low temperature operation causing condensate formation on the primary heat exchanger and operational problems. The cold water supply piping must be installed in the discharge piping from the heater to the storage tank. This allows the cold water to be tempered in the storage tank before entering the heater. See typical installation drawings provided in this manual for correct piping (FIG.'s 9-1 thru 9-4). Higher water temperatures reduce the volume of condensate formed.

CAUTION

Setting the temperature selector to higher settings provides hotter water, which increases the risk of scald injury.

WARNING

Should overheating occur or the gas supply fail to shut off, do not turn off or disconnect the electrical supply to the pump. Instead, shut off the gas supply at a location external to the appliance.

Adjustable high water temperature limit control

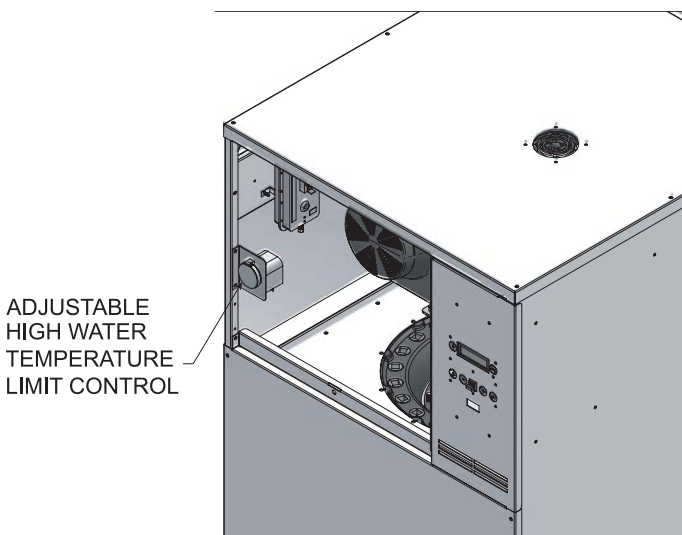

Figure 9-6_Adjustable High Water Temperature Limit Control

A high limit control is located on the inside of the left front panel, as shown in FIG. 9-6. The setting of this control knob limits maximum discharge water temperature. The water heater temperature limit control is adjustable up to a maximum setting of 210°F (99°C). This water heater also includes a fixed high water temperature limit control set to 200° (93.3°C). The RESET key on the display must be pushed whenever water temperature has exceeded the set point of the limit. The temperature of the water in the heat exchanger must drop a minimum of 15°F (8.3°C) below the setting of the high limit control before the reset function can be activated. A high limit message will be shown in the Operator Interface when water temperature exceeds the high water temperature limit control set point.

NOTICE

The high limit control will not reset until the water temperature has dropped below the set point of the high limit.

Optional relief valve

This water heater is normally supplied with a temperature and pressure relief valve sized in accordance with applicable codes. Units may be supplied with an optional pressure only relief valve. When a water heater is equipped with this optional relief valve and is piped to a separate storage vessel, the storage vessel must have a properly installed temperature and pressure relief valve which complies with local codes.

Thermal expansion

A relief valve that discharges periodically may be due to thermal expansion in a closed system. A water heater installed in a closed system, such as one with a backflow preventer or check valve installed in the cold water supply, shall be provided with means to control expansion. Contact the water supplier or local plumbing inspector on how to correct this situation. Do not plug or cap the relief valve discharge.

Cathodic protection

Hydrogen gas can be produced in a hot water system that has not been used for a long period of time (generally two weeks or more). Hydrogen gas is extremely flammable. To prevent the possibility of injury under these conditions, we recommend the hot water faucet be open for several minutes at the kitchen sink before you use any electrical appliance which is connected to the hot water system. If hydrogen is present, there will be an unusual sound such as air escaping through the pipe as the hot water begins to flow. There should be no smoking or open flames near the faucet at the time it is open.

10 Wiring diagram

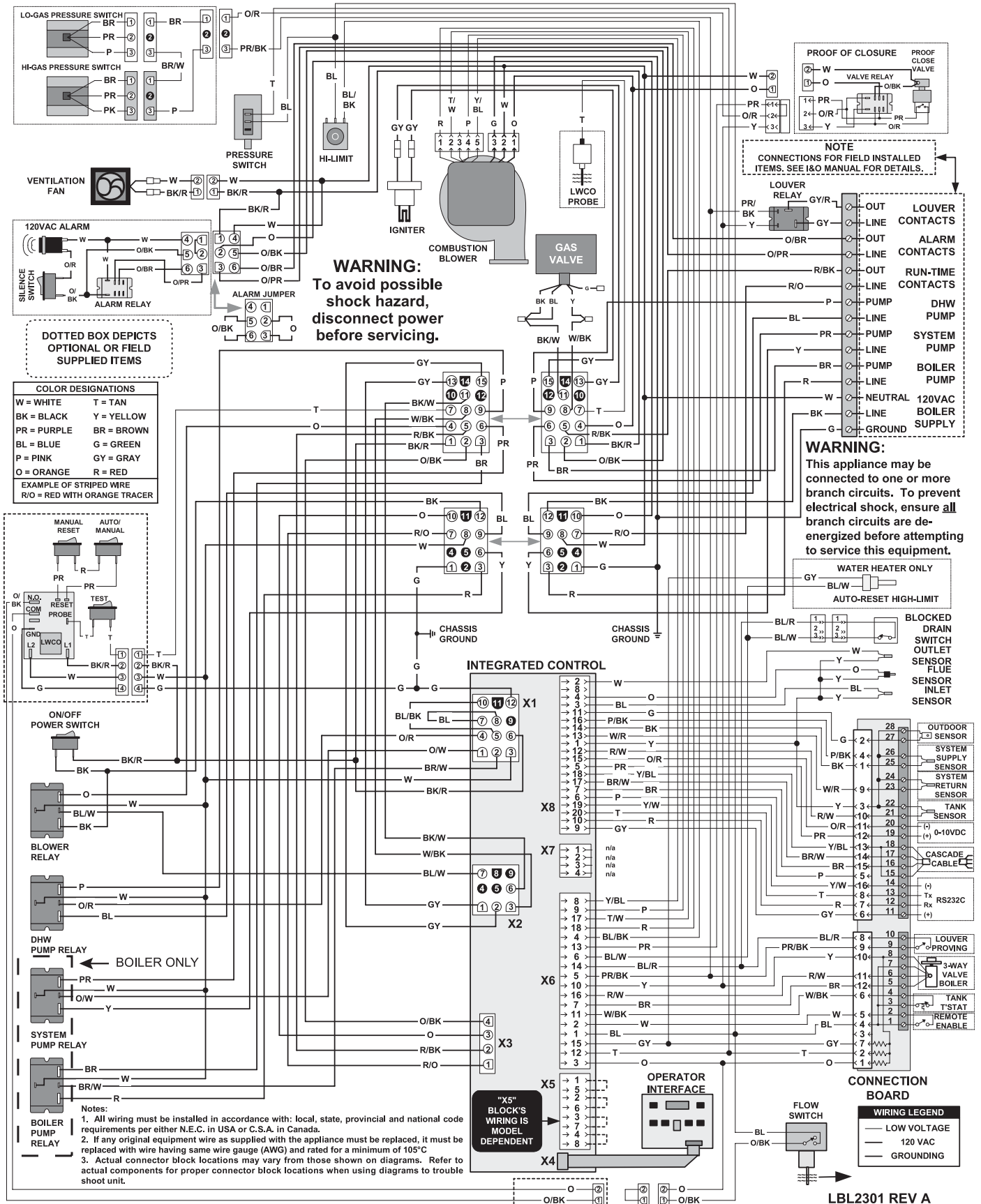

11 Ladder diagram

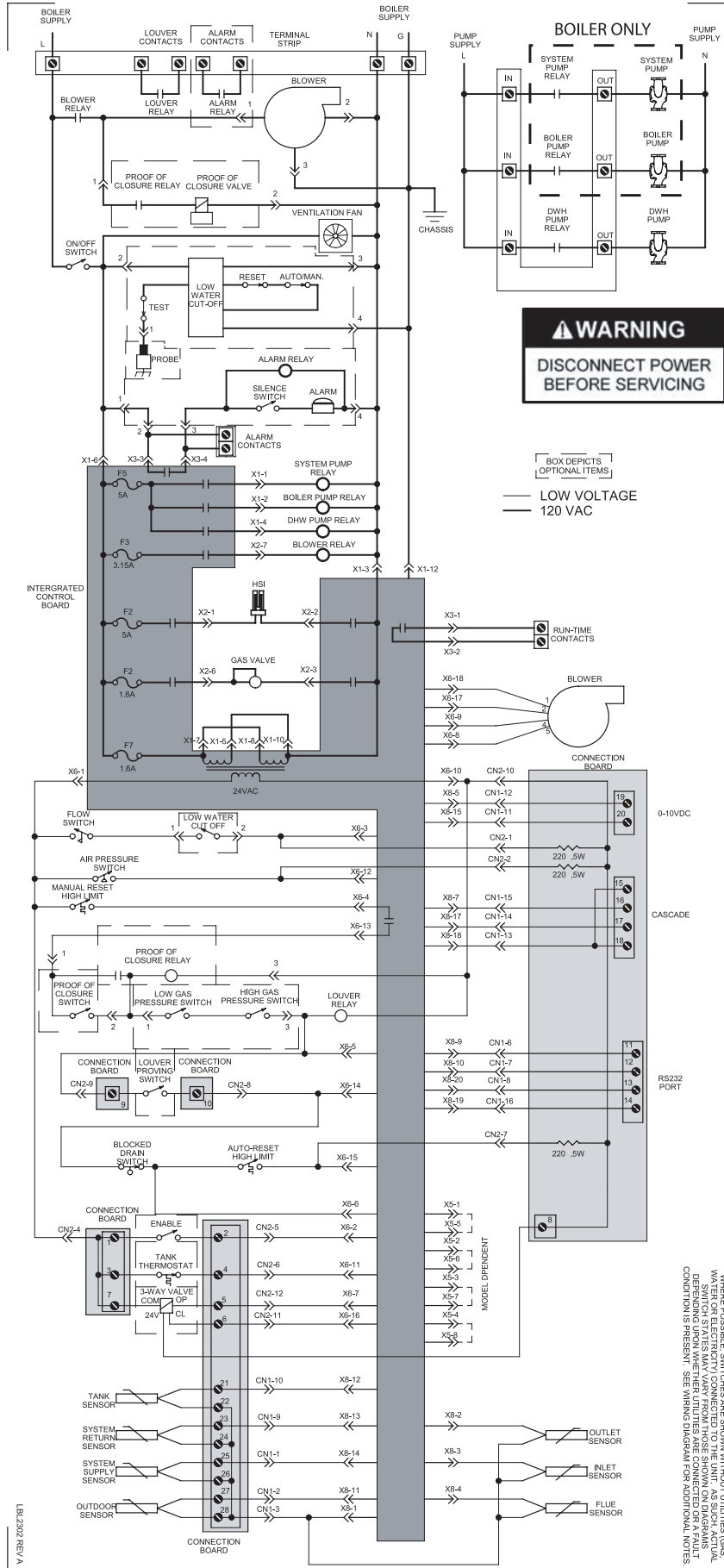

LB1202 REV. A

NOTES

