

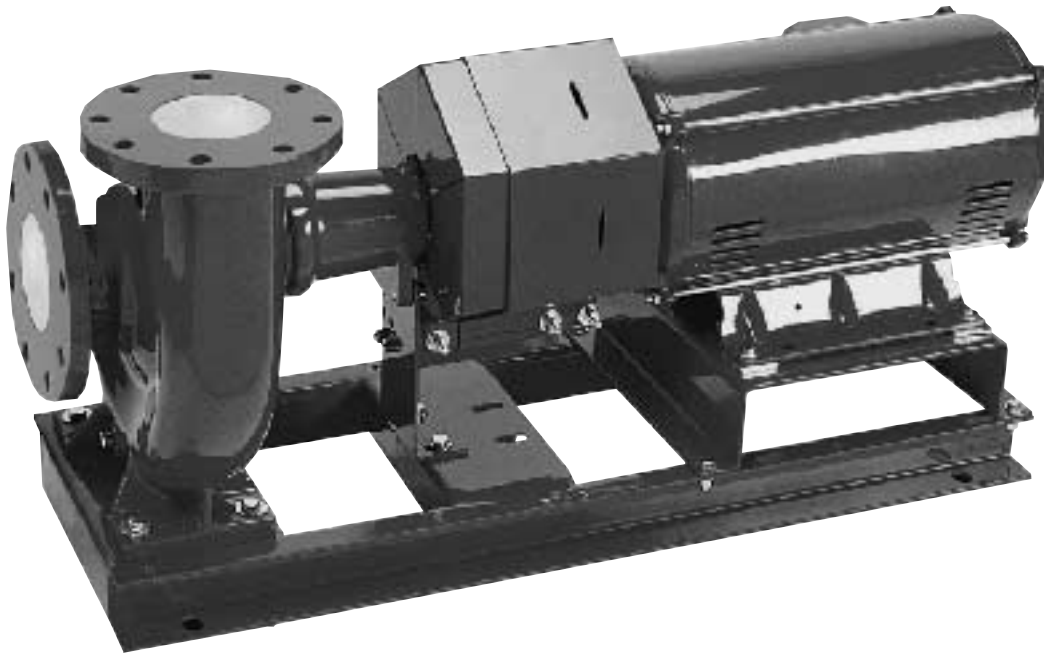

Bell & Gossett

INSTRUCTION MANUAL

P81673
REVISION F



Series 1510 and 1510/Universal Centrifugal Pumps

Installation, Operation and Service Instructions

INSTALLER: PLEASE LEAVE THIS MANUAL FOR THE OWNER'S USE.

Bell & Gossett



ITT Industries
Engineered for life

DESCRIPTION

The Series 1510 centrifugal pump is a frame mounted pump which features – high efficiency, rugged construction, foot mounted volute with back pullout bearing frame, center drop out coupler and regreasable bearings. These features make installation, operation and service easy to perform.

PUMP APPLICATION

The standard Series 1510 centrifugal pump's bronze fitted construction make it ideal for service with following liquids: unheated domestic and fresh water, boiler feed water, condensate, hydronic cooling or heating, pressure boosting, general pumping and benign liquids.

For other applications contact your local B&G Representative.

OPERATION LIMITS

Unless special provisions have been made for your pump by Bell & Gossett, the operational limits for Series 1510 Pumps are as follows:

Maximum Working Pressure

Listed on pump nameplate.

SEAL OPERATING LIMITS

Standard Seals

BUNA-PH Limitations 7-9; Temperature Range -40 to +225°F
 EPTH-PH Limitations 7-11; Temperature Range -40 to + 250°F
 For use on closed or open systems which are relatively free of dirt and/or other abrasive particles.

Flushed Single Seals

PH Limitations 7-9; Temperature Range 0 to +250°F†

NOTE: On closed or open low pressure systems that contain a high concentration of abrasives an external flush is required.

Flushed Double Seals

PH Limitations 7-9; Temperature Range 0 to +250°F

NOTE: On closed or open low pressure systems that contain a high concentration of abrasives an external flush is required.

Packing

PH Limitations 7-9; Temperature Range 0 to +200°F

For use on open or closed systems which require a large amount of makeup water, as well as systems which are subjected to widely varying chemical conditions and solids buildup.

† For operating temperatures above 250°F a cooled flush is required and is recommended for temperatures above 225°F for optimum seal life. On closed systems cooling is accomplished by inserting a small heat exchanger in the flush line to cool the seal flushing fluid.

Flush-line Filters and Sediment Separators are available on special request.

SAFETY INSTRUCTIONS

This safety alert symbol will be used in this manual and on the pump Safety Instruction decal to draw attention to safety related instructions. When used, the safety alert symbol means ATTENTION! BECOME ALERT! YOUR SAFETY IS INVOLVED! FAILURE TO FOLLOW THE INSTRUCTIONS MAY RESULT IN A SAFETY HAZARD.

Your Series 1510 Pump should have the following safety instruction decals located approximately as shown. If the decals are missing or illegible contact your local B&G Representative for a replacement.

Additional Safety Requirements:

1. Electrical connections to be made by qualified Electrician in accordance with all National, State and Local codes.
2. Motor must have properly sized starter with properly sized heaters to provide overload and undervoltage protection.
3. If pump, motor or piping are operating at extremely high or low temperatures, guarding or insulation is required.
4. The maximum working pressure of the pump is listed on the pump nameplate, do not exceed this pressure.

FIGURE 3

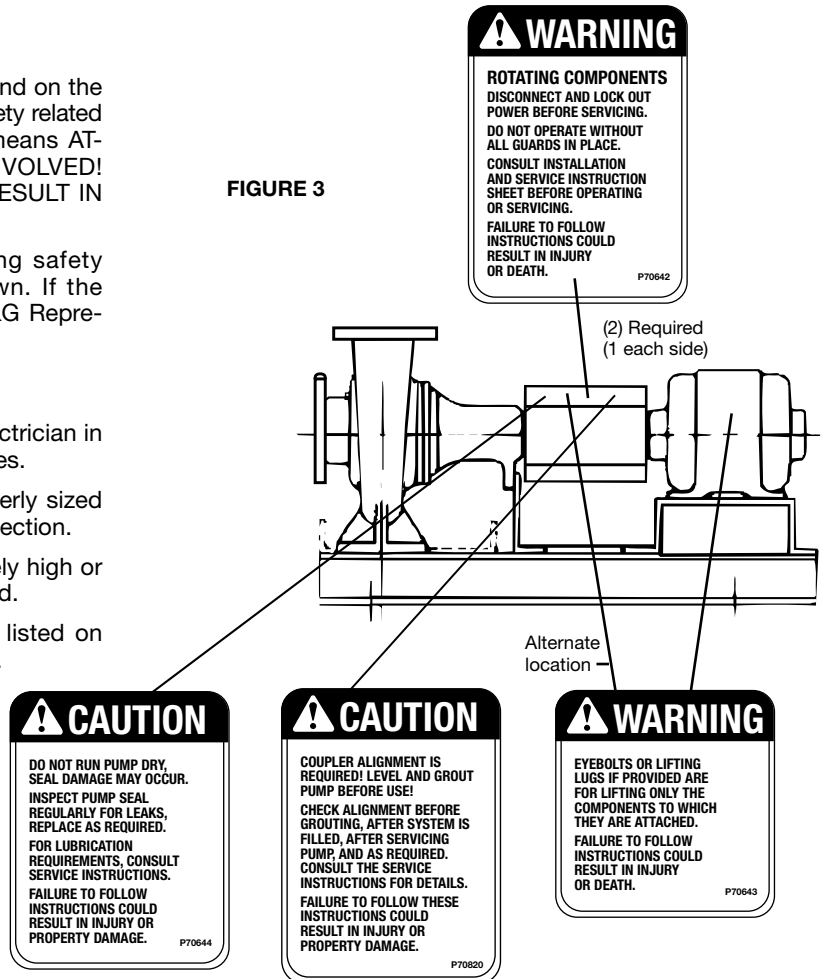

ADDITIONAL SAFETY REQUIREMENTS:

ELECTRICAL SAFETY:

WARNING: Electrical Shock Hazard
Electrical connections to be made by a qualified electrician in accordance with all applicable codes, ordinances, and good practices. Failure to follow these instructions could result in serious personal injury or death, or property damage.

WARNING: Electrical Overload Hazard
Three phase motors must have properly sized heaters to provide overload and undervoltage protection. Single phase motors have built-in overload protectors. Failure to follow these instructions could result in serious personal injury or death, or property damage.

THERMAL SAFETY:

WARNING: Extreme Temperature Hazard
If pump, motor, or piping are operating at extremely high or low temperatures, guarding or insulation is required. Failure to follow these instructions could result in serious personal injury or death, or property damage.

MECHANICAL SAFETY:

WARNING: Unexpected Startup Hazard
Disconnect and lockout power before servicing. Failure to follow these instructions could result in serious personal injury or death, or property damage.

WARNING: Excessive System Pressure Hazard
The maximum working pressure of the pump is listed on the nameplate, do not exceed this pressure. Failure to follow these instructions could result in serious personal injury or death, or property damage.

**WARNING: Excessive Pressure Hazard
Volumetric Expansion**
The heating of water and other fluids causes volumetric expansion. The associated forces may cause failure of system components and release of high temperature fluids. This will be prevented by installing properly sized and located compression tanks and pressure relief valves. Failure to follow these instructions could result in serious personal injury or death, or property damage.

PUMP LOCATION

Locate the pump so there is sufficient room for inspection, maintenance and service. If the use of a hoist or tackle is needed, allow ample head room.

WARNING: FALLING OBJECT HAZARD
Eyebolts or lifting lugs if provided are for lifting only the components to which they are attached. Failure to follow these instructions could result in serious personal injury or death, or property damage.

If lifting of the entire pump is required, do so with slings placed under the base rails as shown.

The best pump location for sound and vibration absorption is on a concrete floor with subsoil underneath. If the pump location is overhead, special precautions should be undertaken to reduce possible sound transmission, consult a sound specialist.

If the pump is not on a closed system, it should be placed as near as possible to the source of the liquid supply, and located to permit installation with the fewest number of bends or elbows in the suction pipe.

The installation must be evaluated to determine that the Net Positive Suction Head Available (NPSHA) meets or exceeds the Net Positive Suction Head Required (NPSHR), as stated by the pump performance curve.

IMPORTANT

Do not install and operate Bell & Gossett Pumps, 3D Valves, Suction Diffusers, etc., in closed systems unless the system is constructed with properly sized safety devices and control devices. Such devices include the use of properly sized and located pressure relief valves, compression tanks, pressure controls, temperature controls, and flow controls as appropriate. If the system does not include these devices, consult the responsible engineer or architect before making pumps operational.

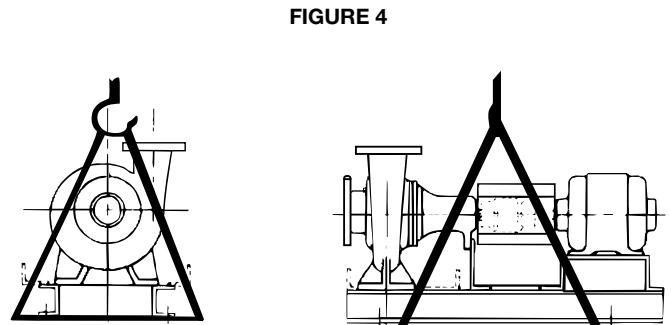

FIGURE 4

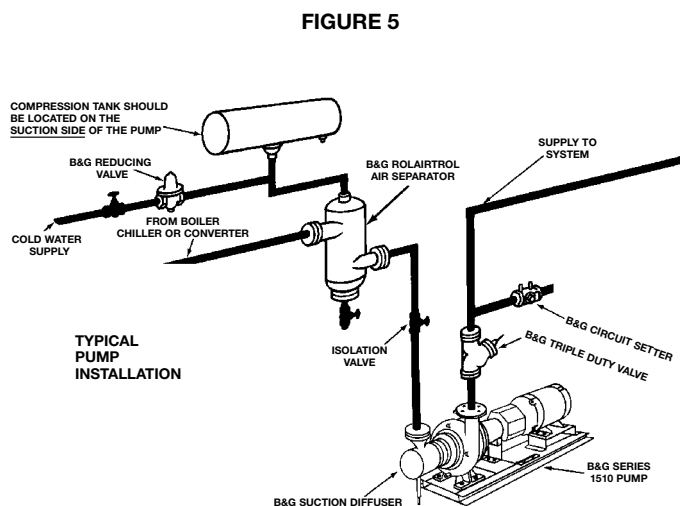

FIGURE 5

INSTALLATION

This pump is built to provide years of service if installed properly and attached to a suitable foundation. A base of concrete weighing 2½ times the weight of the pump is recommended. (Check the shipping ticket for pump weight.)

If possible, tie the concrete pad in with the finished floor. Use foundation bolts and larger pipe-sleeves to give room for final bolt location. (See Figure 6A.)

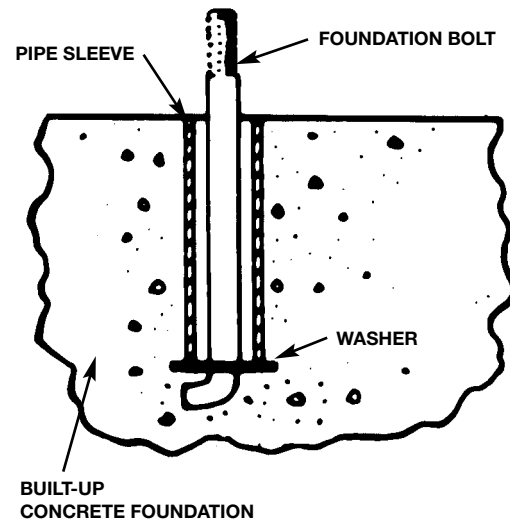
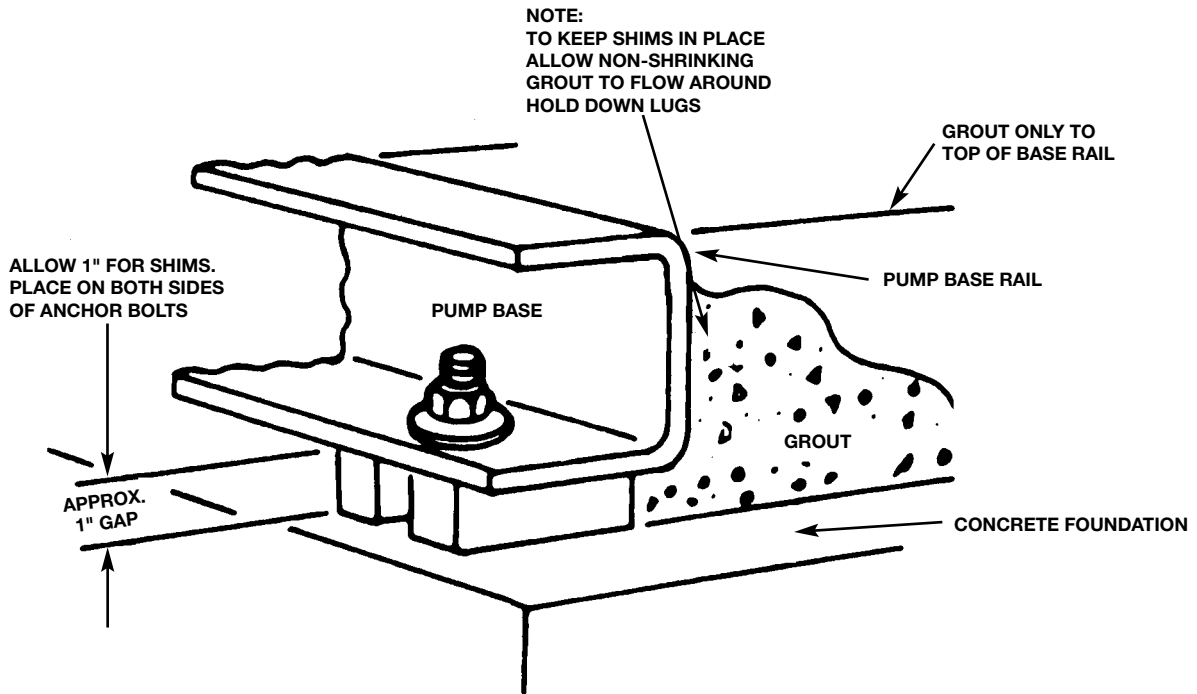

FIGURE 6A

INSTALLATION OF FOUNDATION BOLTS

FIGURE 6B LEVELING OF PUMP BASE ON CONCRETE FOUNDATION



LEVELING

Place the pump on its concrete foundation supporting it with steel wedges or shims totaling 1" in thickness. These wedges or shims should be put on both sides of each anchor-bolt to provide a means of leveling the base. (See Figure 6B.)

IT IS VERY IMPORTANT THAT THE PUMP-BASE BE SET LEVEL TO AVOID ANY MECHANICAL DIFFICULTIES WITH THE MOTOR OR PUMP. THIS PUMP WAS PROPERLY ALIGNED (IF FURNISHED WITH A MOTOR) AT THE FACTORY. HOWEVER, SINCE ALL PUMP BASES ARE FLEXIBLE THEY MAY SPRING AND TWIST DURING SHIPMENT. DON'T PIPE THE PUMP UNTIL IT IS REALIGNED. AFTER PIPING IS COMPLETED AND AFTER THE PUMP IS GROUTED-IN AND BOLTED-DOWN, ALIGN IT AGAIN. IT MAY BE NECESSARY TO RE-ADJUST THE ALIGNMENT FROM TIME TO TIME WHILE THE UNIT AND FOUNDATION ARE NEW.

GROUTING

After the pump has been leveled, securely bolted to the floor, and properly aligned, a good grade of non-shrinking grout should be poured inside the pump base. To hold wedges or shims in place, allow the grout to flow around them. (See Figure 6B).

ROTATION

Pump rotation is clockwise when viewed from back of the motor. An arrow is also located on the pump to show the direction of rotation.

COUPLER ALIGNMENT

All alignment should be done by moving or shimming the motor only. Adjustments in one direction may alter alignment in another. Therefore, check alignment in all directions after a correction is made. **Black rubber sleeves have different horsepower load ratings than orange Hytrel sleeves, they should not be interchanged.**



WARNING: UNEXPECTED STARTUP HAZARD

Disconnect and lockout power before servicing. Failure to follow these instructions could result in serious personal injury or death, or property damage.

Standard Sleeve Type Coupler with Black Rubber Sleeve

Before aligning the coupler, make sure there is at least $\frac{1}{8}$ " end clearance between the sleeve and the two coupler halves.

1. Check angular misalignment using a micrometer or caliper. Measure from the outside face of one flange to the outside face of the opposite flange at four points 90° apart. Refer to figure 7B. **DO NOT ROTATE COUPLER.** Misalignment up to $\frac{1}{64}$ " per inch of coupler radius is permissible.
2. At four points 90° apart (**DO NOT ROTATE COUPLER**), measure the parallel coupler misalignment by laying a straight edge across one coupler half and measuring the gap between the straight edge and opposite coupler half. Up to a $\frac{1}{64}$ " gap is permissible. Refer to figure 7A.

For Fine Alignment, Orange Hytrel Sleeves, 3500 RPM Operation, or All Other Coupler Types

Use a dial indicator when greater alignment accuracy is required. Use the following alignment tolerances unless specified otherwise by the coupler manufacturer. On sleeve type couplers make sure there is at least $\frac{1}{8}$ " end clearance between the sleeve and the two coupler halves.

PIPING

Always install a section of straight pipe between the suction side of the pump and first elbow or install a B&G Suction Diffuser. This reduces turbulence of the suction by straightening out the flow of liquid before it enters the pump. The length should be equal to five times the diameter of the pipe.

Be sure to eliminate any pipe-strain on the pump. Support the suction and discharge pipes independently by use of pipe hangers near the pump. Line up the piping so that the bolt-holes in the pump flanges match the bolt-holes in the pipe flanges. **DO NOT ATTEMPT TO SPRING THE SUCTION OR DISCHARGE LINES INTO POSITION.** Coupling and bearing wear will result if suction or discharge lines are forced into position. The code for Pressure Piping (A.S.A.B. 31.1) lists many types of supports available for various applications.

1. To check angular misalignment, mount the dial indicator base to one coupler half, or shaft, and position the dial indicator button on the front or rear face of the opposite coupler half. Set the dial to zero. Rotate both coupler halves **together**, making sure the indicator button always indicates off the same spot. Misalignment values within 0.004" TIR per inch of coupler radius are permissible.
2. To check parallel misalignment, mount the dial indicator base to one coupler half, or shaft, and position the dial indicator button on the outside diameter of the opposite coupler half. Set the dial to zero. Rotate both coupler halves **together**, making sure the indicator button always indicates off the same spot. Misalignment within 0.004" TIR is permissible.

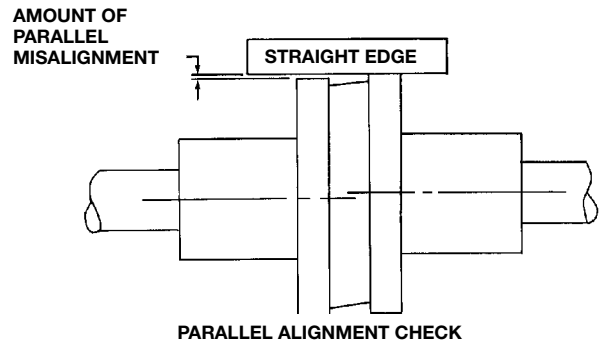

FIGURE 7A

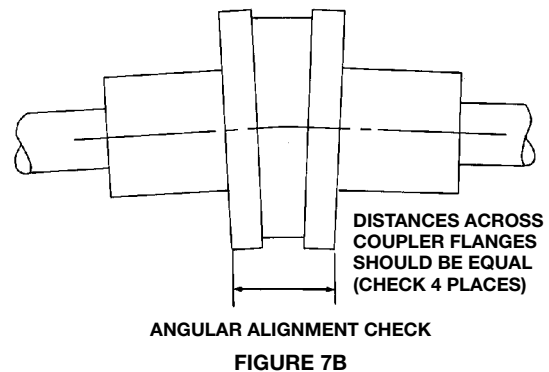

FIGURE 7B



WARNING: ROTATING COMPONENT HAZARD

Do not operate pump without all guards in place. Failure to follow these instructions could result in serious personal injury or death, or property damage.

As a rule, ordinary wire or band hangers are not adequate to maintain alignment. It is very important to provide a strong, rigid support for the suction and discharge lines.

Where considerable temperature changes are anticipated, fittings for absorbing expansion should be installed in the system in such a way as to avoid strain on the pump.

On an open-system with a suction-lift, use a foot-valve of equal or greater area than the pump suction piping. Prevent clogging by using a strainer at the suction inlet next to the foot-valve. The strainer should have an area three times that of the suction pipe with a mesh hole diameter of no less than $\frac{1}{4}$ ".

When using an isolation base, flexible piping should be used on both the suction and discharge sides of the pump.

A Triple Duty Valve, such as the one manufactured by Bell & Gossett, installed in the discharge line will serve as a check valve to protect the pump from water hammer, as an isolation valve for servicing and for throttling.

NOTES:

1. The pipeline should have isolation valves around the pump and have a drain valve in the suction pipe.
2. When installing the suction and discharge connections to a threaded pump housing the use of teflon tape sealer or a high quality thread sealant is recommended.

PUMP INSULATION

When insulating a Series 1510 pump, ensure that the bearing assembly grease fittings remain accessible and visible. The vent slots on the sides and bottom of the bearing assembly should remain uncovered and completely open.

LUBRICATION

While pump is running regrease pump bearing with NLGI Grade #2 lithium base petroleum grease after every 2500 hours of operation or every 6 months whichever occurs first.

Lubricate motor per motor manufacturer’s instructions.

GENERAL INSTRUCTIONS

1. Keep this pump and motor properly lubricated.
2. When there is a danger of freezing, drain the pump.
3. Inspect pump regularly for leaky seals or gaskets and loose or damaged components. Replace or repair as required.

HEX GUARD EXPLODED VIEW FOR TYPICAL INSTALLATION

FIGURE 8

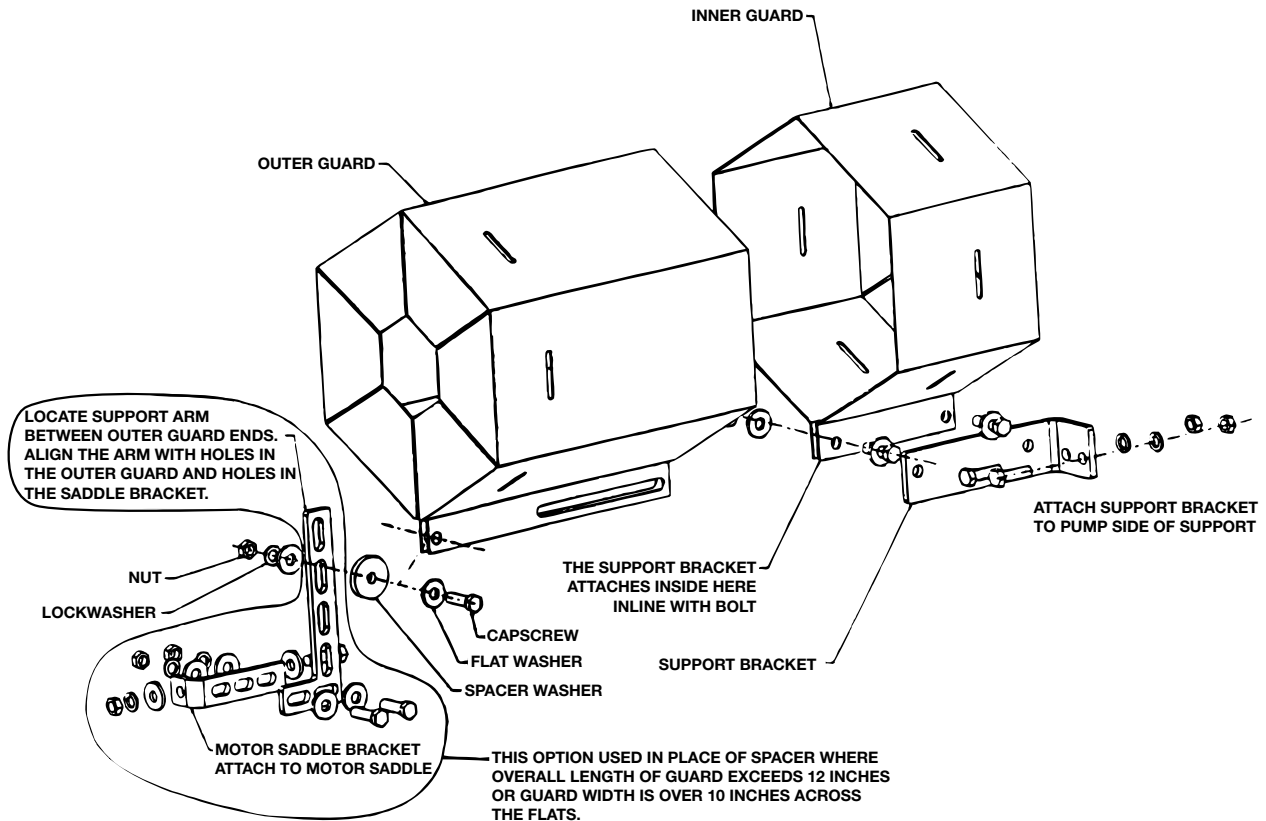

STANDARD MECHANICAL SEAL CONSTRUCTION

FIGURE 9

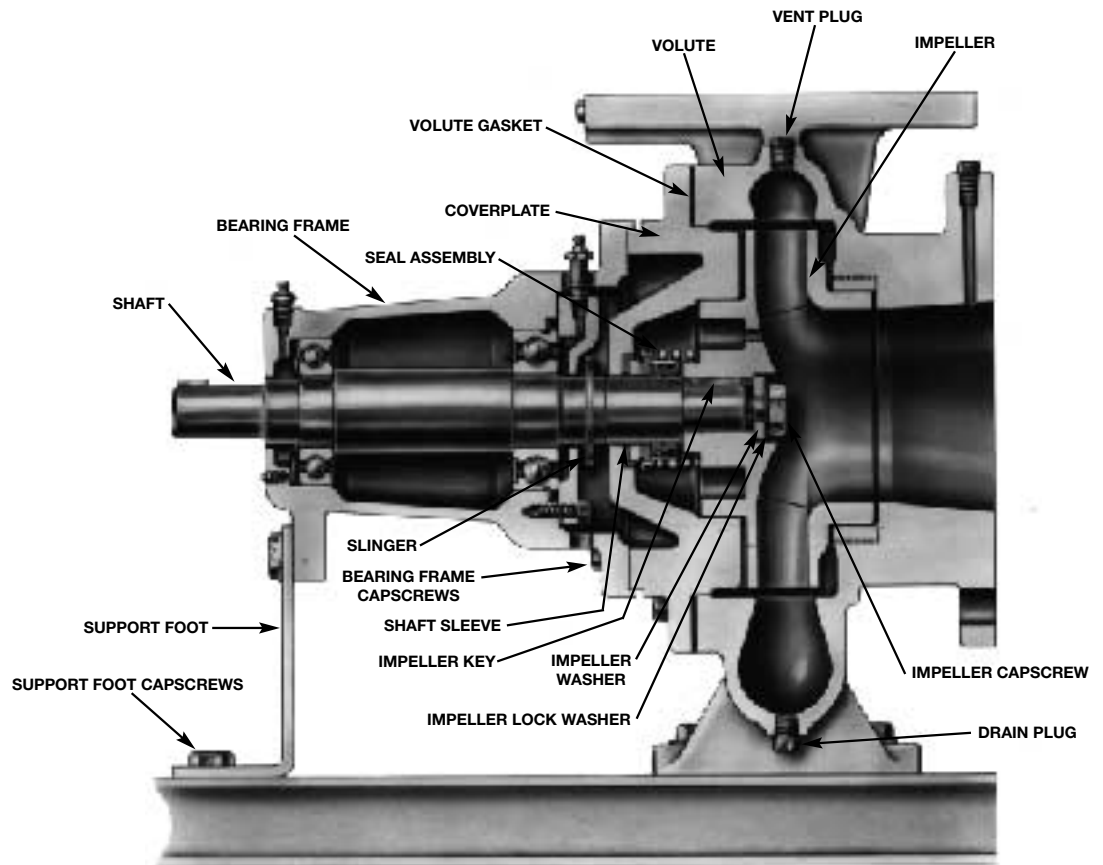

STUFFING BOX CONSTRUCTION

FIGURE 10

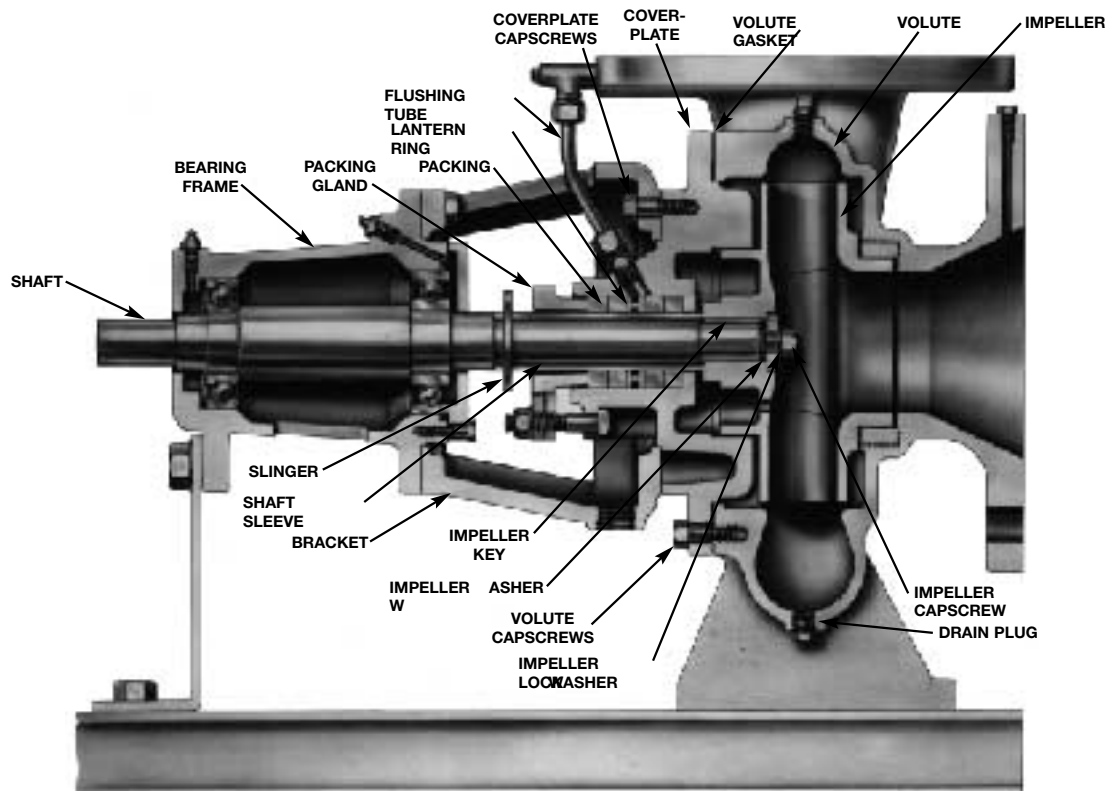

FIGURE 11
1510-S

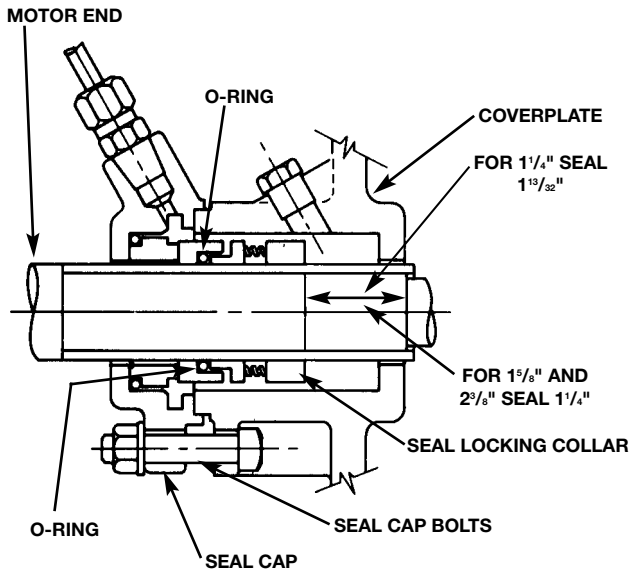
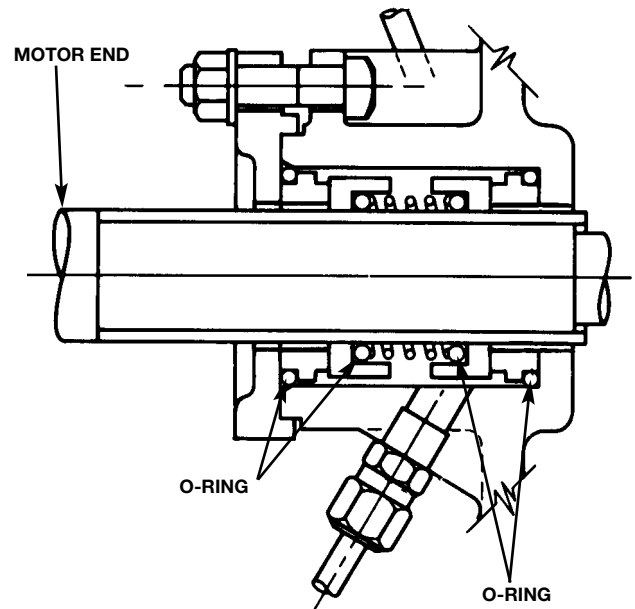

FIGURE 12
1510-D



SERVICE INSTRUCTIONS



WARNING: UNEXPECTED STARTUP HAZARD

Disconnect and lock out power before servicing. Failure to follow these instructions could result in serious personal injury or death, or property damage.

1. Close valves on suction and discharge sides of pump. (If no valves have been installed, it will be necessary to drain the system.)



CAUTION: EXTREME TEMPERATURE HAZARD

Allow pump temperature to reach acceptable levels before proceeding. Open drain valve, do not proceed until liquid stops coming out of drain valve. If liquid does not stop flowing from drain valve, isolation valves are not sealing and should be repaired before proceeding. After liquid stops flowing from the drain valve, leave valve open and continue. Remove the drain plug located on the bottom of the pump housing. Do not reinstall plug or close drain valve until re-assembly is completed. Failure to follow these instructions could result in property damage and/or moderate personal injury.

2. Remove the Hex Coupler Guard as follows (see figure 8):
 - a. Remove the two cap screws that hold the outer (motor side) coupler guard to the support bracket(s).
 - b. Spread the outer guard and pull it off the inner guard. **NOTE:** Do not spread the inner and outer guards more than necessary for guard removal. Over spreading the guards may alter their fit and appearance.
 - c. Remove the cap screw that holds the inner guard to the support bracket.
 - d. Spread the inner guard and pull it over the coupler.

3. Loosen set screws in both coupler halves and slide each half back as far as possible on its shaft. Remove coupler sleeve. Where a full diameter impeller is used, it may be necessary to remove the pump side coupler half and to slide the motor back on its base in order to gain sufficient clearance to remove the pump assembly from the volute.

4. Remove support foot capscrews. Loosen volute capscrews, do not remove them. Use capscrews in the jack screw holes (Not on 8G). Loosen the pump assembly from the volute.



WARNING: EXCESSIVE PRESSURE HAZARD

Make certain internal pressure of the pump is relieved before continuing. Failure to follow these instructions could result in serious personal injury or death, or property damage.

Remove seal flushing tube, if used.

Remove the volute capscrews and remove the pump assembly from the volute.

Continue to the section which pertains to your pump type.

1510 and 1510-F

With Standard Mechanical Seal – Figure 9

5. Remove the impeller capscrew, lock washer and washer. Remove the impeller.
6. Remove the rotating portion of the seal, use a screwdriver to loosen the rubber ring.
7. Remove the seal insert along with the insert gasket and retainer (if used).
8. Thoroughly clean the shaft sleeve and the coverplate seal cavity. Inspect for surface damage like pitting, corrosion, nicks or scratches. Replace if necessary.

9. Lubricate the shaft sleeve and coverplate seal cavity with soapy water (do not use petroleum lubricant). Install a new insert gasket and a new seal insert with indentation side down into the cup.
10. Slide a new rotating seal assembly onto the shaft sleeve. With a screwdriver push on the top of the compression ring until the seal is tight against the seal insert. Install seal spring, with narrow end toward seal.
11. Install impeller, impeller washer, lock washer and cap-screw. Tighten capscrew per torque chart (See Table 1).
12. Install new volute gasket then install pump assembly into volute. Tighten volute capscrews per torque chart (See Table 1). Install seal flushing tube, if used. Install support foot capscrews and tighten per torque chart (See Table 1). Install coupler and align. Install drain plug, close drain valve.
13. Install the Hex Coupler Guard as follows:
 - a. Spread the inner guard and place it over the coupler. **NOTE:** Do not spread the inner and outer guards more than necessary for guard installation. Over spreading the guards may alter their fit and appearance.
 - b. With the inner guard straddling the support bracket, install a cap screw through the hole in the support bracket and guard located closest to the pump. Do not tighten the capscrew.
 - c. Spread the outer guard and place it over the inner guard.
 - d. Install the outer guard cap screws by following the step stated below which pertains to your particular pump:
 - i) *For pumps with a motor saddle support bracket:* Ensure the outer guard is straddling the support arm, and install but do not tighten the two remaining cap screws.
 - ii) *For pumps without a motor saddle support bracket:* Insert the spacer washer between the holes located closest to the motor in the outer guard, and install but do not tighten the two remaining cap screws.
 - e. Position the outer guard so it is centered around the shaft, and so there is less than a 1/4" of shaft exposed.
 - f. Holding the guard in this position, tighten the three cap screws.
14. Open isolation valves, inspect pump for leaks, if not leaking return pump to service.
9. Assemble coverplate to bracket, tighten capscrews per torque chart (See Table 1). Assemble seal cap to coverplate, tighten hex nuts on seal cap bolts per torque chart (See Table 1).
10. Go to Step 11 of 1510 Standard Mechanical Seal Instructions.

**1510-D Stuffing Box
With Special Double Mechanical Seal – Figure 10 and 12**

5. Remove the impeller capscrew, lock washer and washer. Remove the impeller.
6. Remove hex nuts from seal cap bolts and remove coverplate capscrews. Remove coverplate from bracket.
7. Remove seal assembly. Thoroughly clean and inspect shaft sleeve, seal cap, and coverplate seal cavity, replace if required.
8. Lubricate shaft sleeve, seal cap and coverplate cavity with soapy water (do not use petroleum lubricant). Insert one stationary seal and O-ring into seal cap and the other into the coverplate.* Slide the seal cap onto the shaft. Replace seal cap gasket.* Slide rotating portion of seal assembly onto shaft sleeve.
9. Assemble coverplate to bracket, tighten capscrews per torque chart (See Table 1). Assemble seal cap to coverplate, tighten hex nuts on seal cap bolts per torque chart (See Table 1).
10. Go to Step 11 of 1510 Standard Mechanical Seal Instructions.

*For 1 1/4" I.D. Seal both parts will be housed in the coverplate as shown in Figure 12. Seal cap gasket is not used.



**1510-8G
With Standard Mechanical Seal – Figure 13**

5. Remove the impeller nut and washer. Remove the impeller and impeller key.
6. Remove spacer sleeve and two nuts holding the gland to the stuffing box.
7. Pull the coverplate off the bearing frame assembly. Remove the seal, sleeve and gland.
8. Thoroughly clean the shaft, shaft sleeve and the coverplate seal cavity. Inspect for surface damage like pitting, corrosion, nicks or scratches.
9. Apply Dow Corning Silicone Rubber #732 or equal to the shaft at sleeve location. Slide the shaft sleeve onto the shaft and spin sleeve to distribute sealant. Wipe off excess.
10. Slide the seal gland (flat side towards the stuffing box) on the shaft.
11. Lubricate the outer surface of the shaft sleeve, interior of the stuffing box and seal elastomer with soapy water (do not use petroleum lubricant). Install the stationary element and rotating assembly of the mechanical seal on the shaft sleeve; being certain that the two wearing surfaces face each other and rotating half of the seal is installed closest to the impeller end.
12. Install the seal spring and spring retainer onto the shaft sleeve. Slide the coverplate onto the bearing frame.
13. Install spacer sleeve (over the shaft sleeve), impeller key, impeller, washer and impeller nut, then tighten impeller nut to 25-30 ft-lbs. Install and tighten the gland nuts evenly against the stuffing box.

**1510-S Stuffing Box
With Special Single Mechanical Seal – Figure 10 and 11**

5. Remove the impeller capscrew, lock washer and washer. Remove the impeller.
6. Remove hex nuts from seal cap bolts and remove coverplate capscrews. Remove coverplate from bracket.
7. Remove seal assembly. Thoroughly clean and inspect seal sleeve and seal cap, replace if required.
8. Lubricate shaft sleeve and seal cap with soapy water (do not use petroleum lubricant). Insert stationary seal with O-ring into the seal cap and slide onto the shaft. Replace the seal cap gasket. Slide rotating portion of the seal assembly onto shaft sleeve and lock in place. For 1 1/4" I.D. seals, the collar should be 1 13/32" from the impeller end of the shaft sleeve. For 1 5/8" and 2 3/8" I.D. seals, the distance should be 1 1/4". (See Figure 11).

TABLE 1 – TORQUE CHART

Capscrew Type	Head Marking	CAPSCREW TORQUE (FOOT-POUND)					
		Capscrew Diameter					
		1/4	5/16	3/8	7/16	1/2	5/8
SAE Grade 1 & 2		3	6	10	16	24	46
Stainless Steel							
SAE Grade 5		8	17	30	50	76	48

DEALER SERVICING

If trouble occurs that cannot be rectified contact your local representative. He will need the following information in order to give you assistance.

1. Complete nameplate data of pump and motor.
2. Suction and discharge pipe pressure gauge readings.
3. Ampere draw of the motor.
4. A sketch of the pump hook-up and piping.



Bell & Gossett

© COPYRIGHT 1970, 1999 BY ITT INDUSTRIES, INC.
PRINTED IN U.S.A. 6-99

USA
Bell & Gossett
8200 N. Austin Avenue
Morton Grove, IL 60053
Phone: (847) 966-3700
Facsimile: (847) 966-9052
<http://www.bellgossett.com>



INTL.
Bell & Gossett / Export Dept.
8200 N. Austin Avenue
Morton Grove, IL 60053
Phone: (847) 966-3700
Facsimile: (847) 966-8366
Cable: BELGOSSETT

CANADA
Fluid Products Canada
55 Royal Road
Guelph, Ontario,
N1H 1T1, Canada
Phone: (519) 821-1900