



# Installation Instructions

## CONTENTS

	Page
<b>SAFETY CONSIDERATIONS</b> .....	1
<b>INTRODUCTION</b> .....	1-3
<b>INSTALLATION</b> .....	3-55
<b>Storage</b> .....	3
<b>Step 1 — Rig and Place the Unit.</b> .....	3
• PLACING UNIT	
• MOUNTING UNIT	
• RIGGING UNIT	
<b>Step 2 — Remove Compressor Rack Holddown Bolts</b> .....	28
<b>Step 3 — Cooler Fluid and Drain Piping Connections</b> .....	28
• FREEZE PROTECTION	
• UNITS WITH HYDRONIC PUMP PACKAGE	
• UNITS WITHOUT HYDRONIC PUMP PACKAGE	
• FOR ALL UNITS	
<b>Step 4 — Fill the Chilled Water Loop</b> .....	33
• WATER SYSTEM CLEANING	
• WATER TREATMENT	
• SYSTEM PRESSURIZATION	
• FILLING THE SYSTEM	
• SET WATER FLOW RATE	
• PUMP MODIFICATION/TRIMMING	
• PREPARATION FOR YEAR-ROUND OPERATION	
• FREEZE PROTECTION	
• PREPARATION FOR WINTER SHUTDOWN	
<b>Step 5 — Make Electrical Connections</b> .....	43
• POWER SUPPLY	
• POWER WIRING	
• CONTROL POWER	
• FIELD CONTROL OPTION WIRING	
• DUAL CHILLER LEAVING WATER SENSOR	
• CARRIER COMFORT NETWORK® COMMUNICATION BUS WIRING	
• NON-CCN COMMUNICATION WIRING	
<b>Step 6 — Install Accessories</b> .....	55
• NAVIGATOR™ DISPLAY	
• REMOTE ENHANCED DISPLAY	
• LOW AMBIENT TEMPERATURE OPERATION	
• MINIMUM LOAD ACCESSORY	
• UNIT SECURITY/PROTECTION ACCESSORIES	
• COMMUNICATION ACCESSORIES	
• SERVICE OPTIONS	
<b>Step 7 — Refrigerant Circuit</b> .....	55
• LEAK TESTING	
• DEHYDRATION	
• REFRIGERANT CHARGE	

## SAFETY CONSIDERATIONS

Installing, starting up, and servicing air-conditioning equipment can be hazardous due to system pressures, electrical components, and equipment location.

Only trained, qualified installers and service mechanics should install, start up, and service this equipment.

Untrained personnel can perform basic maintenance functions such as cleaning coils. All other operations should be performed by trained service personnel.

When working on the equipment, observe precautions in the literature and on tags, stickers, and labels attached to the equipment.

- Follow all safety codes.
- Keep quenching cloth and fire extinguisher nearby when brazing.
- Wear safety glasses and work gloves.
- Use care in handling, rigging, and setting bulky equipment.

**⚠ WARNING**

Electrical shock can cause personal injury and death. Shut off all power to this equipment during installation. There may be more than one disconnect switch. Tag all disconnect locations to alert others not to restore power until work is completed.

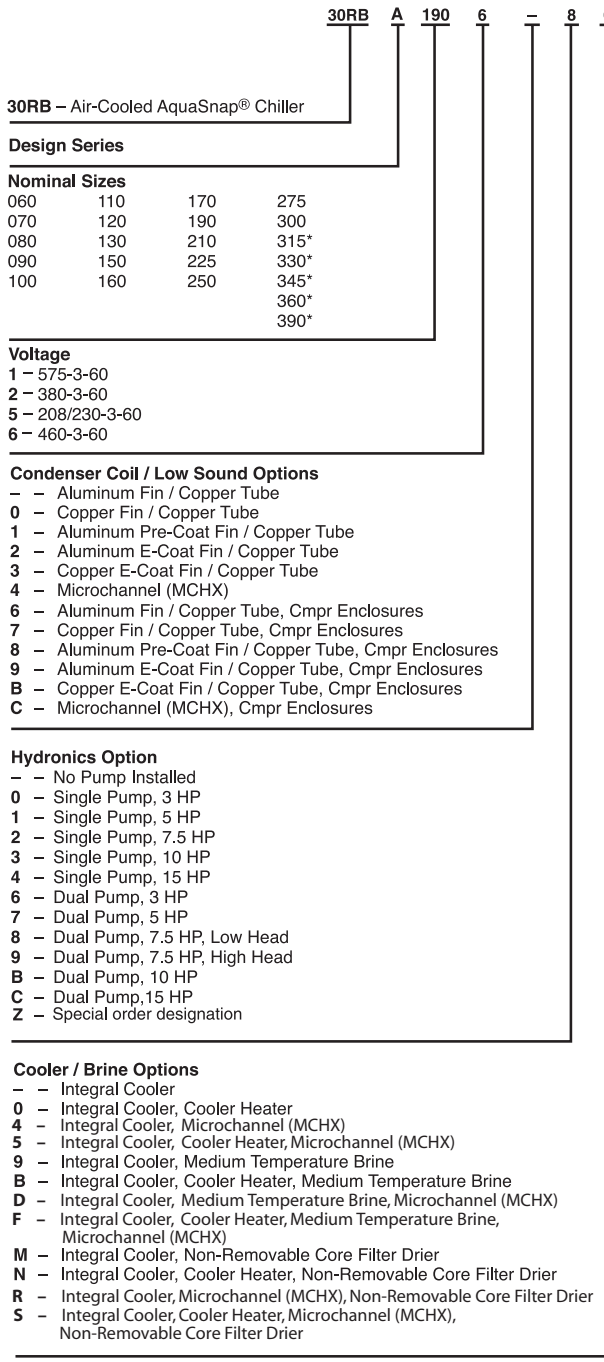
IMPORTANT: This equipment generates, uses, and can radiate radio frequency energy and if not installed and used in accordance with these instructions may cause radio interference. It has been tested and found to comply with the limits of a Class A computing device as defined by FCC (Federal Communications Commission, U.S.A.) regulations, Subpart J of Part 15, which are designed to provide reasonable protection against such interference when operated in a commercial environment.

**⚠ CAUTION**

This system uses Puron® R-410a refrigerant, which has higher pressures than R-22 and other refrigerants. No other refrigerant can be used in this system. Failure to use gage set, hoses, and recovery systems designed to handle Puron R-410a refrigerant may result in equipment damage or personal injury. If unsure about equipment, consult the equipment manufacturer.

## INTRODUCTION

These instructions cover installation of 30RB060-390 air-cooled liquid chillers with electronic controls and units with factory-installed options (FIOPs). See Fig. 1.



- Security/Packaging Option**
- L – Coil Face Shipping Protection
  - 0 – Skid, Coil Face Shipping Protection
  - 1 – Skid, Top Crate and Bag
  - 3 – Coil Face Shipping Protection, Condenser Coil Trim Panels
  - 4 – Skid, Condenser Coil Trim Panels
  - 5 – Skid, Top Crate and Bag, Condenser Coil Trim Panels
  - 7 – Coil Face Shipping Protection, Condenser Coil Trim Panels, Upper and Lower Grilles
  - 8 – Skid, Condenser Coil Trim Panels, Upper and Lower Grilles
  - 9 – Skid, Top Crate and Bag, Condenser Coil Trim Panels, Upper and Lower Grilles
  - C – Coil Face Shipping Protection, Condenser Coil Trim Panels, Upper and Lower Grilles, Hail Guards
  - D – Skid, Condenser Coil Trim Panels, Upper Grilles and Lower Grilles, Hail Guards
  - F – Skid, Top Crate and Bag, Condenser Coil Trim Panels, Upper and Lower Grilles, Hail Guards
  - H – Skid, SCCR
  - J – Skid, Top Crate, Bag, SCCR
  - K – Coil Face Shipping Protection, SCCR
  - M – Coil Face Shipping Protection, Coil Trim Panels, SCCR
  - N – Skid, Coil Trim Panels, SCCR
  - P – Skid, Top Crate, Bag, Coil Trim Panels, SCCR
  - R – Coil Face Shipping Protection, Coil Trim Panels, SCCR
  - S – Skid, Coil Trim Panels, Upper and Lower Grilles, SCCR
  - T – Skid, Top Crate, Bag, Coil Trim Panels, Upper and Lower Grilles, SCCR
  - W – Coil Face Shipping Protection, Coil Trim Panels, Upper and Lower Grilles, Hail Guards, SCCR
  - X – Skid, Coil Trim Panels, Upper and Lower Grilles, Hail Guards, SCCR
  - Y – Skid, Top Crate, Bag, Coil Trim Panels, Upper and Lower Grilles, Hail Guards, SCCR

- Controls/Communication Option**
- None
  - 0 – EMM
  - 1 – Remote Service Port, GFI-CO
  - 2 – EMM, Remote Service Port, GFI-CO
  - 7 – BACnet™ Translator
  - 8 – BACnet Translator, EMM
  - 9 – BACnet Translator, Remote Service Port, GFI-CO
  - B – BACnet Translator, EMM, Remote Service Port, GFI-CO
  - H – LON Translator
  - J – LON Translator, EMM
  - K – LON Translator, Remote Service Port, GFI-CO
  - L – LON Translator, EMM, Remote Service Port, GFI-CO

- Electrical Option**
- Single Power Connection, Terminal Block, XL
  - 3 – Dual Power Connection, Terminal Block, XL
  - 7 – Single Power Connection, Non-Fused Disconnect, XL
  - C – Dual Power Connection, Non-Fused Disconnect, XL

- Refrigeration Circuit Option**
- No Suction Line Insulation
  - 0 – Suction Insulation
  - 1 – Suction Service Valves
  - 2 – Low Ambient Head Pressure Control Operation
  - 3 – Suction Insulation, Suction Service Valves
  - 4 – Suction Insulation, Low Ambient Head Pressure Control Operation
  - 5 – Suction Service Valves, Low Ambient Head Pressure Control Operation
  - 6 – Suction Insulation, Service Valves, Low Ambient Head Pressure Control Operation
  - 7 – Minimum Load Control
  - 8 – Suction Insulation, Minimum Load Control Operation
  - 9 – Suction Service Valves, Minimum Load Control Operation
  - B – Low Ambient Operation, Minimum Load Control Operation
  - C – Suction Insulation, Suction Service Valves, Minimum Load Control Operation
  - D – Suction Insulation, Low Ambient Head Pressure Control Operation, Minimum Load Control Operation
  - F – Suction Service Valves, Low Ambient Head Pressure Control Operation, Minimum Load Control Operation
  - G – Suction Insulation, Suction Service Valves, Low Ambient Head Pressure Control Operation, Minimum Load Control Operation

**LEGEND**

- EMM – Energy Management Module
- GFI-CO – Ground Fault Interrupting Convenience Outlet
- LON – Local Operating Network
- SCCR – Short Circuit Current Rating

\*Refer to Table 1 on this page for modular unit combinations.  
 NOTE: A "Z" in position 11 indicates a special order machine.  
 Digits following do not correspond to tables.

**Quality Assurance**  
 Certified to ISO 9001:2000

**Fig. 1 — AquaSnap® Chiller Model Number Designation**

NOTE: Unit sizes 315-390 are modular units that are shipped in separate sections as modules A or B as noted in position 8 of the unit model nomenclature. Installation directions specific to these units are noted in these instructions. For modules 315A, 315B, 330A, 330B, 345A, 345B, and 360B, follow all general instructions as noted for unit sizes 30RB160-170. For modules, 360A, 390A, and 390B follow instructions for 30RB190. See Table 1 for a listing of unit sizes and modular combinations.

NOTE: The nameplate for modular units contains only the first two digits in the model number. For example, 315A and 315B nameplates read 31A and 31B.

**Table 1 — Modular Combinations**

MODULE UNITS	MODULE A	MODULE B
30RBA315	30RBA160	30RBA160
30RBA330	30RBA170	30RBA160
30RBA345	30RBA170	30RBA170
30RBA360	30RBA190	30RBA170
30RBA390	30RBA190	30RBA190

NOTE: An "A" in the model number indicates the design series.

## INSTALLATION

**Storage** — If the unit is to be stored for a period of time before installation or start-up, be sure to protect the machine from construction dirt and moisture. Keep protective shipping covers in place until machine is ready for installation.

### Step 1 — Place, Rig and Mount the Unit

NOTE: Inspect the unit upon arrival for damage. If damage is found, file a claim right away with the shipping company.

**PLACING UNIT** — When considering location for the unit, be sure to consult National Electrical Code (NEC, U.S.A.) and local code requirements. Allow sufficient space for airflow, wiring, piping, and service. See Fig. 2-13. Be sure surface beneath the unit is level, and is capable of supporting the operating weight of the unit. See Fig. 14 and Tables 2-4B for unit lifting points, mounting and operating weights.

Locate the unit so that the condenser airflow is unrestricted both above and on the sides of the unit. Airflow and service clearances are 6 feet (1.8 m) around the unit. Acceptable clearance on the cooler connection side or end opposite the control box unit can be reduced to 3 feet (1 m) without sacrificing performance as long as the remaining three sides are unrestricted. Acceptable clearance on the side with a control box can be reduced to 4 feet (1.3 m) due to NEC regulations, without sacrificing performance as long as the remaining three sides are unrestricted. Provide ample room for servicing and removing cooler. See Fig. 2-13 for required clearances. Local codes for clearances take precedence over the manufacturer's recommendations when local codes call for greater clearances.

Modular units, 30RB315-390 must be installed with a minimum separation end to end of 4 feet (1.3 m) for airflow and service clearance along with NEC regulations.

If multiple units are installed at the same site, a separation of 10 feet (3 m) between the sides of the machines is required to maintain proper airflow and minimize the chances of condenser air recirculation.

**MOUNTING UNIT** — The unit may be mounted on a level pad directly on the base rails, on rails along the long axis of the machine, or on vibration isolation springs. For all units, ensure placement area is strong enough to support unit operating weight. Mounting holes are provided for securing the unit to the pad or vibration isolation springs. The base rail can be point loaded at the mounting points. The base rail is made from steel, which is formed into what is shown in Fig. 15. See Fig. 2-13 for locations of mounting points. At the mounting points, a U-shaped channel is welded into the base rail to provide a flat plate for mounting. See Fig. 16 for mounting plate dimensions.

The 1<sup>9</sup>/<sub>16</sub> in. (40 mm) dimension shown is to the mounting hole from the outside edge of the rail.

NOTE: The 1<sup>9</sup>/<sub>16</sub> in. (40 mm) dimension in Fig. 16 is not the same dimension as the 1.42 in. (36 mm) flange that is turned under the base rail in Fig. 15.

Bolt the unit securely to pad or rails. If vibration isolators (field-supplied) are required for a particular installation, refer to unit weight distribution in Fig. 14 to aid in the proper selection of isolators. The 30RB units can be mounted directly on spring isolators. For each unit or module, the final unit location must be level so that oil will equalize properly.

**RIGGING UNIT** — The 30RB060-390 units are designed for overhead rigging and it is important that this method be used. Holes are provided in frame base channels, marked for rigging (see rigging label on unit). It is recommended that field-supplied shackles be used to facilitate lifting. Secure the shackles to the base rails at the points noted on the rigging label. See Table 2 for the number of lifting points for each unit.

Do not use a forklift truck to move the units.

**Table 2 — Number of Lifting Points for 30RB060-390**

30RB	NUMBER OF LIFTING POINTS
060-150	4
160, 170	6
190-300	8
315A, 315B, 330A, 330B, 345A, 345B, 360A	6
360B, 390A, 390B	8

Use spreader bars to keep cables or chains clear of unit sides. As further protection plywood sheets may be placed against sides of unit, behind cables or chains. Run cables or chains to a central suspension point so that angle from horizontal is not less than 45 degrees. Raise and set unit down carefully. See Fig. 17 and 18 for rigging centers of gravity.

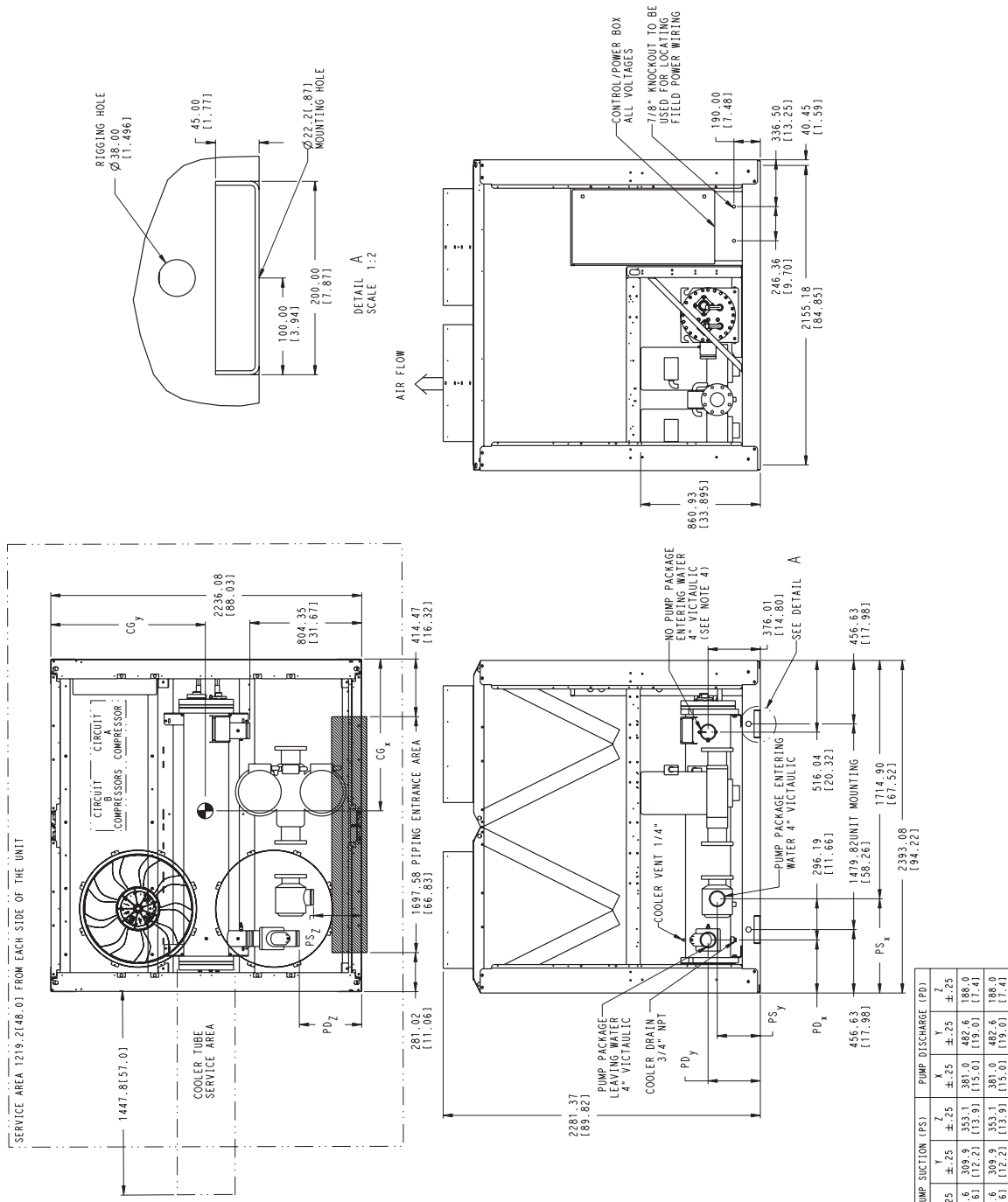
Each module of the 30RB315-390 units must be rigged separately. When placing unit modules for unit sizes 315-390, make sure modules are placed to permit access to the control boxes for each module.

For shipping, some domestic units and all export units are mounted on a wooden skid under entire base of unit. Skid can be removed before unit is moved to installation site. Lift the unit from above to remove skid. See Fig. 17 and 18 for rigging center of gravity. On export units, the top skid can be used as the spreader bars. If the unit was shipped with a shipping bag, the bag must be removed to gain access to the rigging holes in the base rail. On export units with a full crate, the crate sides must be removed to aid in rigging.

If overhead rigging is not available, the unit can be moved on rollers or dragged. When unit is moved on rollers, the unit skid, if equipped, must be removed. To lift the unit, use jacks at the rigging points. Use a minimum number of rollers to distribute the load such that the rollers are no more than 6 feet (1.8 m) apart. If the unit is to be dragged, lift the unit as described above, and place unit on a pad. Apply moving force to the pad, and not the unit. When in its final location, raise the unit and remove the pad.

If the unit was shipped with coil protection, it must be removed before start-up. The shipping bag for export units must be removed before start-up.

NOTE: If the application includes a remote-mounted cooler option, follow the instructions included with the accessory for cooler placement and refrigerant piping.

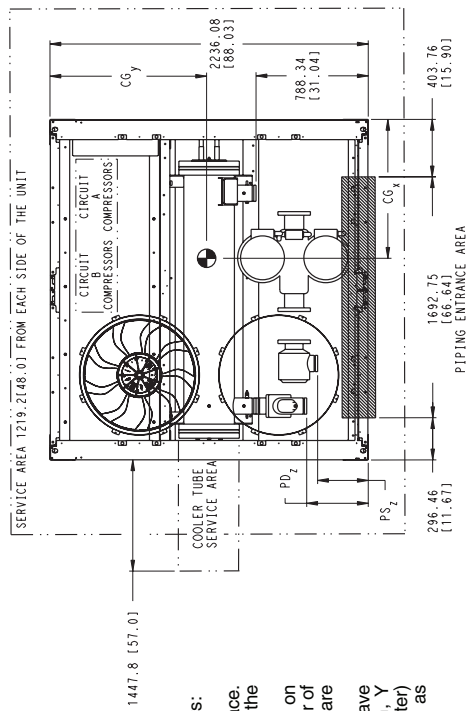


WEIGHT CU/AL lb/kg	MAX WEIGHT CU/AL PUMP lb/kg	WEIGHT CU/AL PUMP lb/kg	MAX WEIGHT CU/AL PUMP lb/kg	WEIGHT MCHX lb/kg	MAX WEIGHT MCHX lb/kg	CENTER OF GRAVITY			PUMP SUCTION (PS)			PUMP DISCHARGE (PD)		
						MM (INCH)	MM (INCH)	MM (INCH)	X	Y	Z	X	Y	Z
30RB-060	4705	4354	5187	3544	4377	1164	1038	1164	675.6	309.9	353.1	381.0	482.6	188.0
	1756	2134	1975	2553	1607	[45.82]	[40.86]	[45.82]	[26.6]	[12.2]	[13.9]	[15.0]	[19.0]	[7.4]
30RB-070	4911	4560	5393	3737	4571	1165	1013	1165	675.6	309.9	353.1	381.0	482.6	188.0
	1849	2228	2068	2446	1695	[45.86]	[39.88]	[45.86]	[26.6]	[12.2]	[13.9]	[15.0]	[19.0]	[7.4]

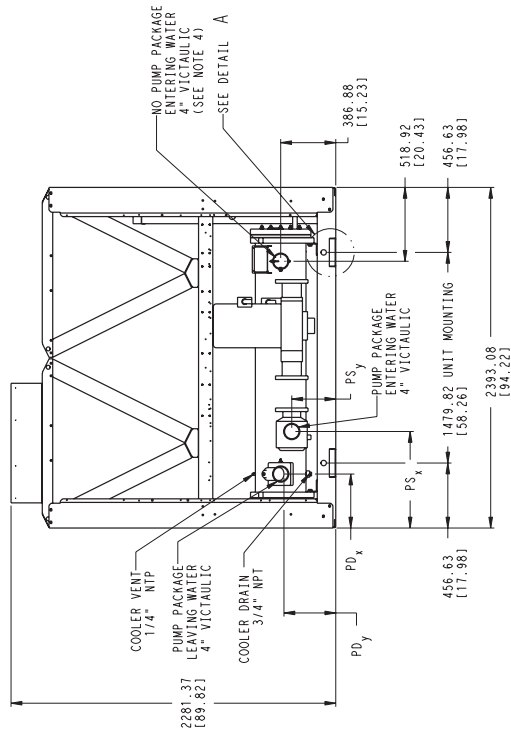
Fig. 2 — 30RB060, 070 Air-Cooled Chiller Dimensions

MCHX — Microchannel Heat Exchanger

- NOTES:
- Unit must have clearances as follows:  
Top — Do not restrict.  
Sides and End — 6" from solid surface.
  - All pumps have drains located at the bottom of volute for draining.
  - Temperature relief devices located on suction line, liquid line and filter drier of each circuit and have 1/4" flare connection.
  - Units without a pump package have the same leaving water connection, Y and Z dimensions, (entering water) and pump discharge X dimensions as units with a pump package.
  - Dimensions are in mm [inches].



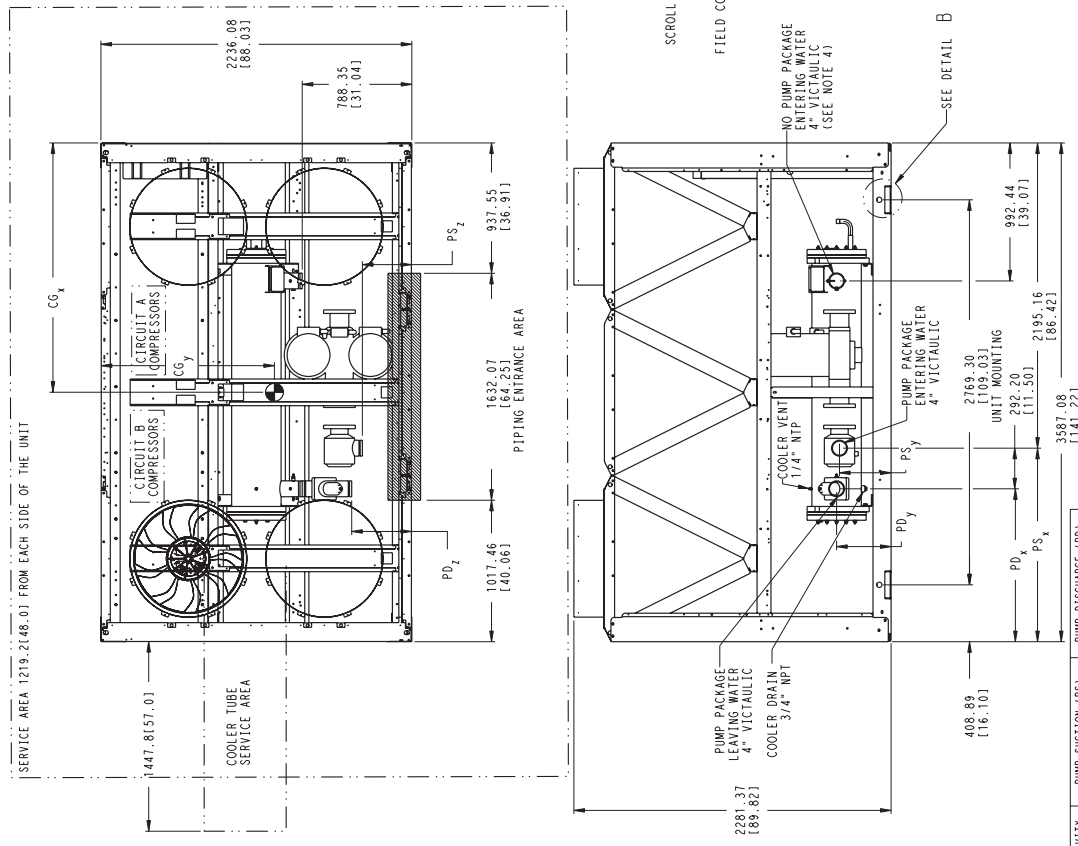
- NOTES:**
- Unit must have clearances as follows:  
Top — Do not restrict.  
Sides and End — 6" from solid surface.
  - All pumps have drains located at the bottom of volute for draining.
  - Temperature relief devices located on suction line, liquid line and filter drier of each circuit and have 1/4" flare connection.
  - Units without a pump package have the same leaving water connection, Y and Z dimensions, (entering water) and pump discharge X dimensions as units with a pump package.
  - Dimensions are in mm [inches].



	WEIGHT CU/AL LB/KG	MAX WEIGHT CU/AL LB/KG	WEIGHT CU/AL LB/KG	MAX WEIGHT CU/AL LB/KG	WEIGHT MCHX LB/KG	MAX WEIGHT MCHX LB/KG	CENTER OF GRAVITY			PUMP SUCTION (PS)			PUMP DISCHARGE (PD)		
							CG-X MM [INCH]	CG-Y MM [INCH]	CG-Z MM [INCH]	X	Y	Z	X	Y	Z
30RB-080	4335	5258	4817	5740	4002	4825	1206	1012	675.6	309.9	353.1	381.0	497.8	170.2	170.2
1986	2385	2885	2185	2604	1815	2234	147.48	139.84	26.6	12.2	13.9	15.0	19.6	6.7	6.7

MCHX — Microchannel Heat Exchanger

Fig. 3 — 30RB080 Air-Cooled Chiller Dimensions

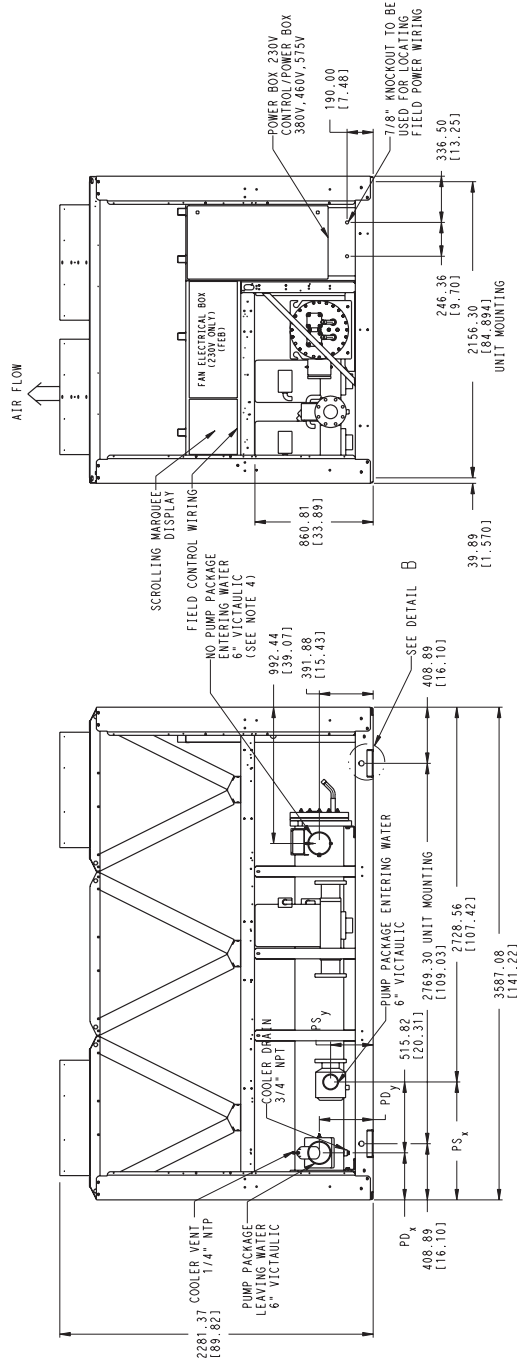
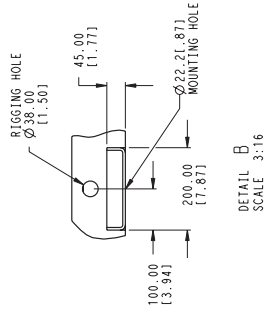
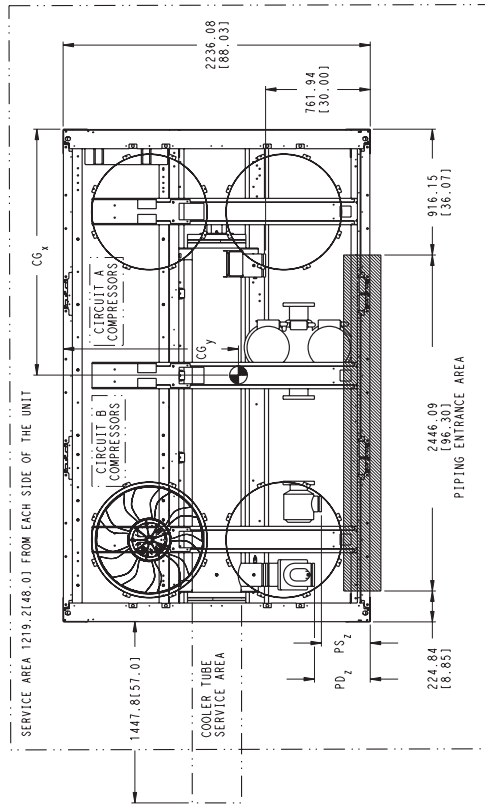


WEIGHT lb./kg	MAX. WEIGHT lb./kg	WEIGHT lb./kg	MAX. WEIGHT lb./kg	WEIGHT lb./kg	MAX. WEIGHT lb./kg	WEIGHT lb./kg	MAX. WEIGHT lb./kg	WEIGHT lb./kg	MAX. WEIGHT lb./kg	WEIGHT lb./kg	MAX. WEIGHT lb./kg
5800	6813	6514	7537	5388	6321	6514	7537	5388	6321	6514	7537
2672	3090	2972	3419	2448	2867	2972	3419	2448	2867	2972	3419

- NOTES:**
- Unit must have clearances as follows:  
Top — Do not restrict.  
Sides and End — 6" from solid surface.
  - All pumps have drains located at the bottom of volute for draining.
  - Temperature relief devices located on suction line, liquid line and filter drier of each circuit and have 1/4" flare connection.
  - Units without a pump package have the same leaving water connection, Y and Z dimensions, (entering water) and pump discharge X dimensions as units with a pump package.
  - Dimensions are in mm [inches].

**Fig. 4 — 30RB090, 100 Air-Cooled Chiller Dimensions**

MCHX — Microchannel Heat Exchanger

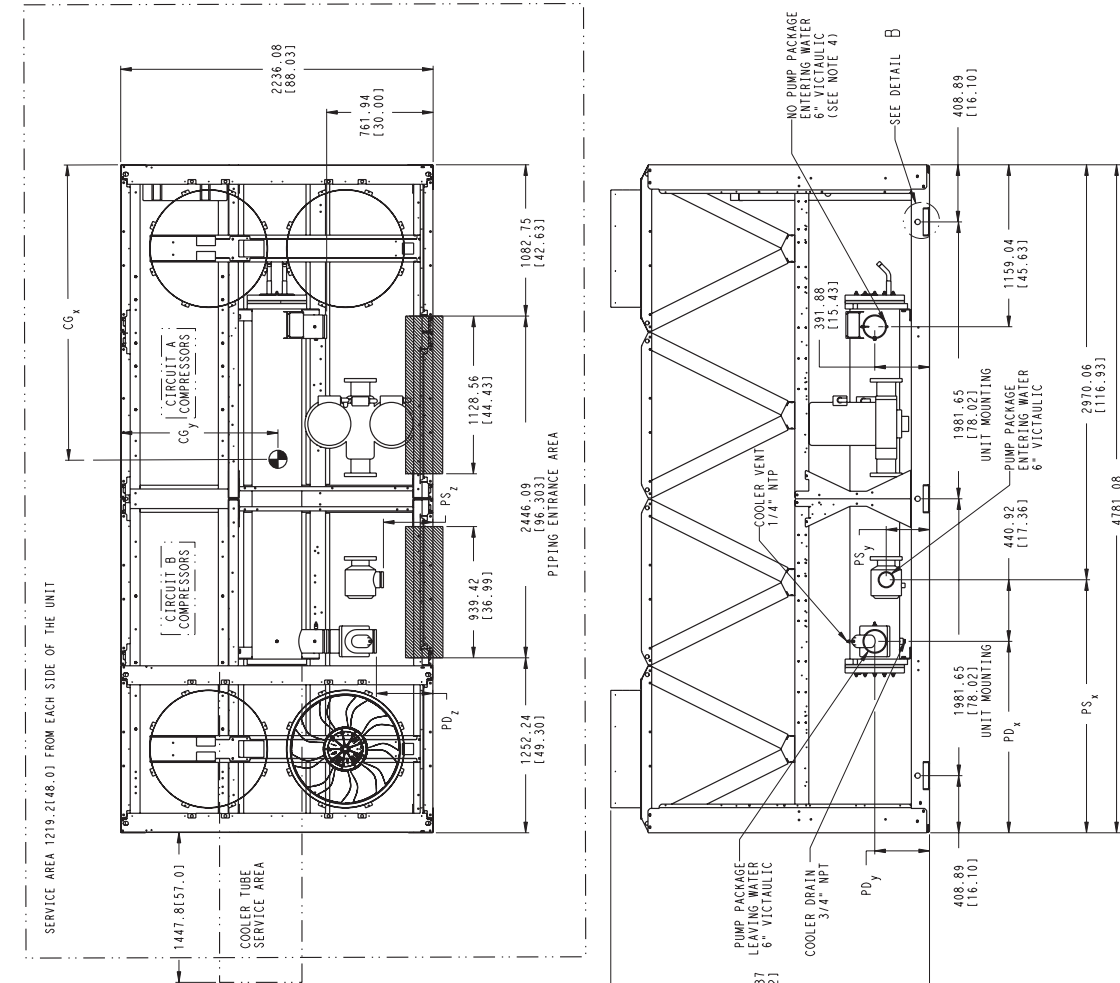


- NOTES:**
1. Unit must have clearances as follows:  
Top — Do not restrict.  
Sides and End — 6" from solid surface.
  2. All pumps have drains located at the bottom of volute for draining.
  3. Temperature relief devices located on suction line, liquid line and filter drier of each circuit and have 1/4" flare connection.
  4. Units without a pump package have the same leaving water connection, Y and Z dimensions, (entering water) and pump discharge X dimensions as units with a pump package.
  5. Dimensions are in mm [inches].

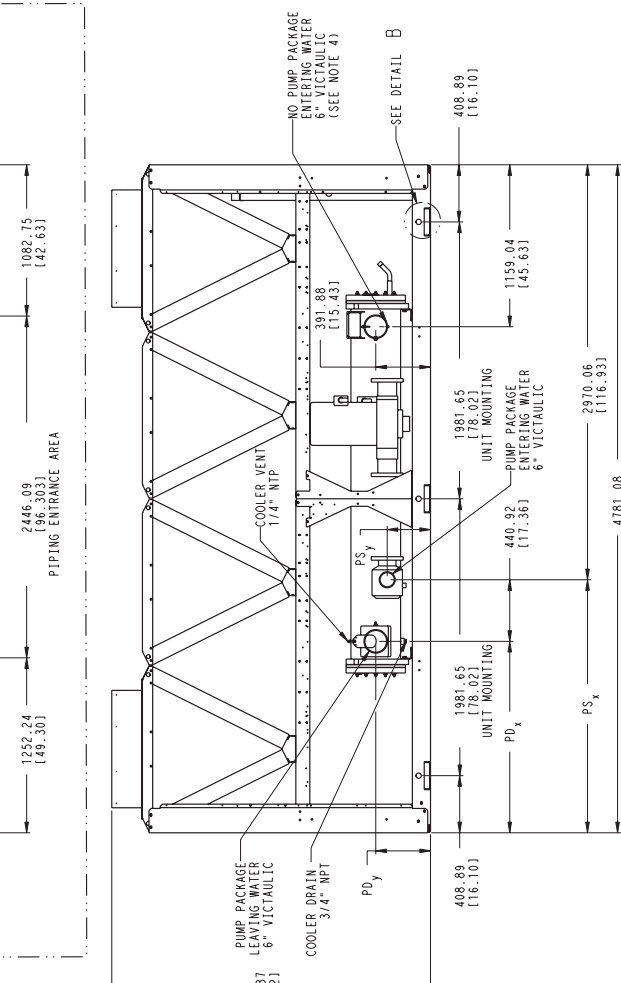
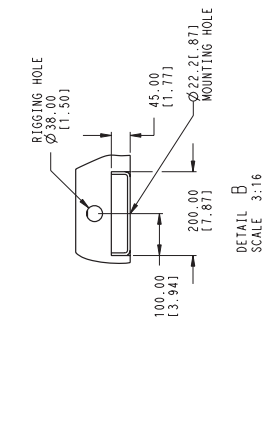
	WEIGHT CU/AL PUMP lb/kg	MAX WEIGHT CU/AL PUMP lb/kg	WEIGHT CU/AL PUMP lb/kg	MAX WEIGHT MCHX PUMP lb/kg	WEIGHT MCHX PUMP lb/kg	CENTER OF GRAVITY			PUMP SUCTION (PS)			PUMP DISCHARGE (PD)				
						CG <sub>x</sub> MM [INCH]	CG <sub>y</sub> MM [INCH]	CG <sub>z</sub> MM [INCH]	X <sub>25</sub> ±.25	Y <sub>25</sub> ±.25	Z <sub>25</sub> ±.25	X <sub>25</sub> ±.25	Y <sub>25</sub> ±.25	Z <sub>25</sub> ±.25		
30RB-110	6144	7067	6868	7791	5652	1713	987	856.0	281.9	60.9	340.4	391.2	233.7	113.4	115.4	9.2
	2187	3206	3115	3534	2563	67.44	39.25	33.71	11.11	12.41	13.41	15.41	9.21	13.41	15.41	9.21

MCHX — Microchannel Heat Exchanger

Fig. 5 — 30RB110 Air-Cooled Chiller Dimensions



- NOTES:**
- Unit must have clearances as follows:  
 Top — Do not restrict.  
 Sides and End — 6" from solid surface.
  - All pumps have drains located at the bottom of volute for draining.
  - Temperature relief devices located on suction line, liquid line and filter drier of each circuit and have 1/4" flare connection.
  - Units without a pump package have the same leaving water connection, Y and Z dimensions, (entering water) and pump discharge X dimensions as units with a pump package.
  - Dimensions are in mm [inches].



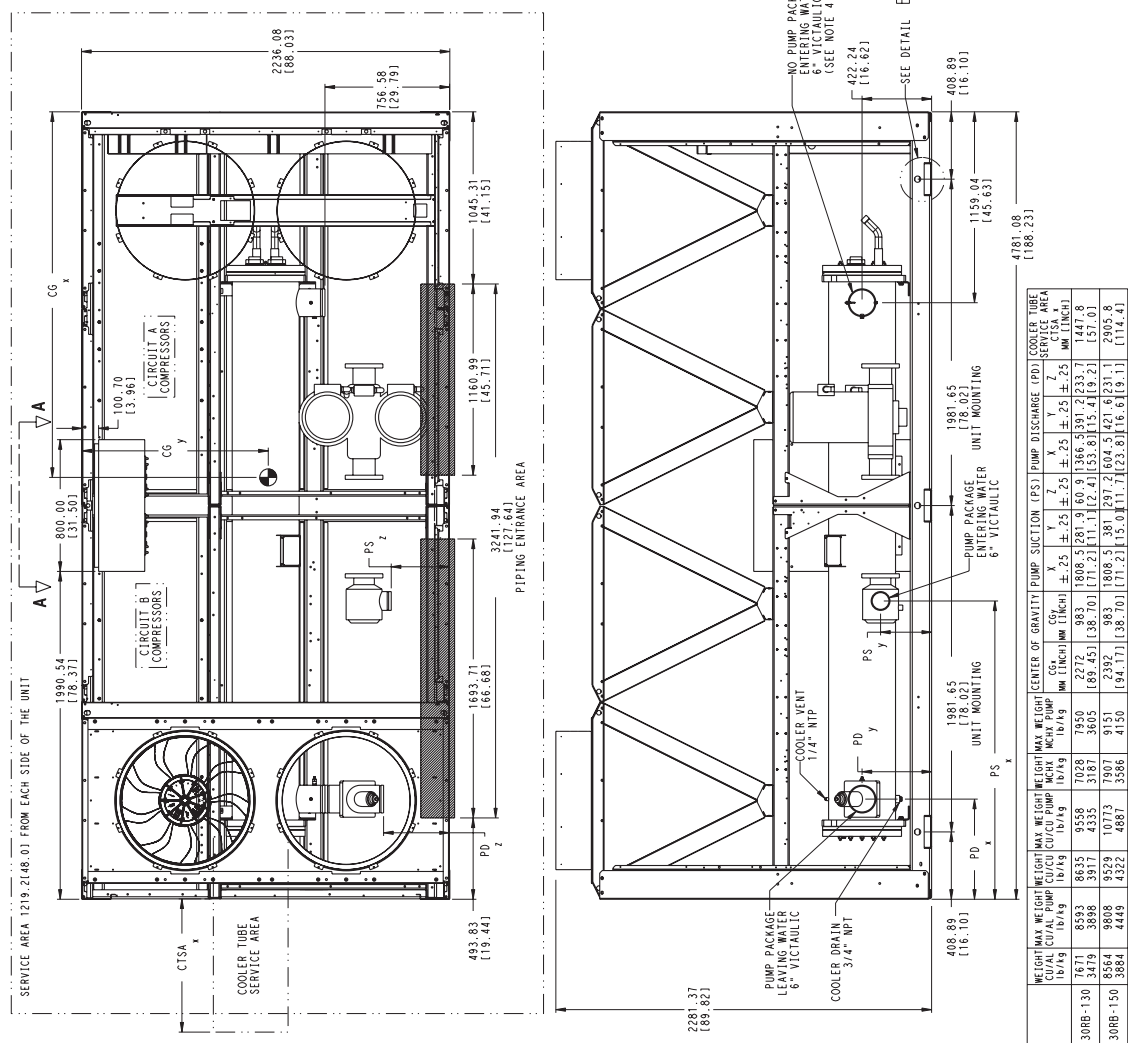
WEIGHT CU/AL lb/kg	MAX WEIGHT CU/AL lb/kg	WEIGHT CU/AL lb/kg	MAX WEIGHT CU/AL lb/kg	WEIGHT MCHX lb/kg	MAX WEIGHT MCHX lb/kg	PUMP SUCTION (PS)			PUMP DISCHARGE (PD)		
						CG <sub>x</sub> MM [INCH]	Y MM [INCH]	Z MM [INCH]	CG <sub>x</sub> MM [INCH]	Y MM [INCH]	Z MM [INCH]
7315	8238	8159	9082	6744	1806.5	281.9	60.9	1366.5	391.2	233.7	±.25
3318	3737	3101	3101	3059	1806.5	281.9	60.9	1366.5	391.2	233.7	±.25

MCHX — Microchannel Heat Exchanger

Fig. 6 — 30RB120 Air-Cooled Chiller Dimensions



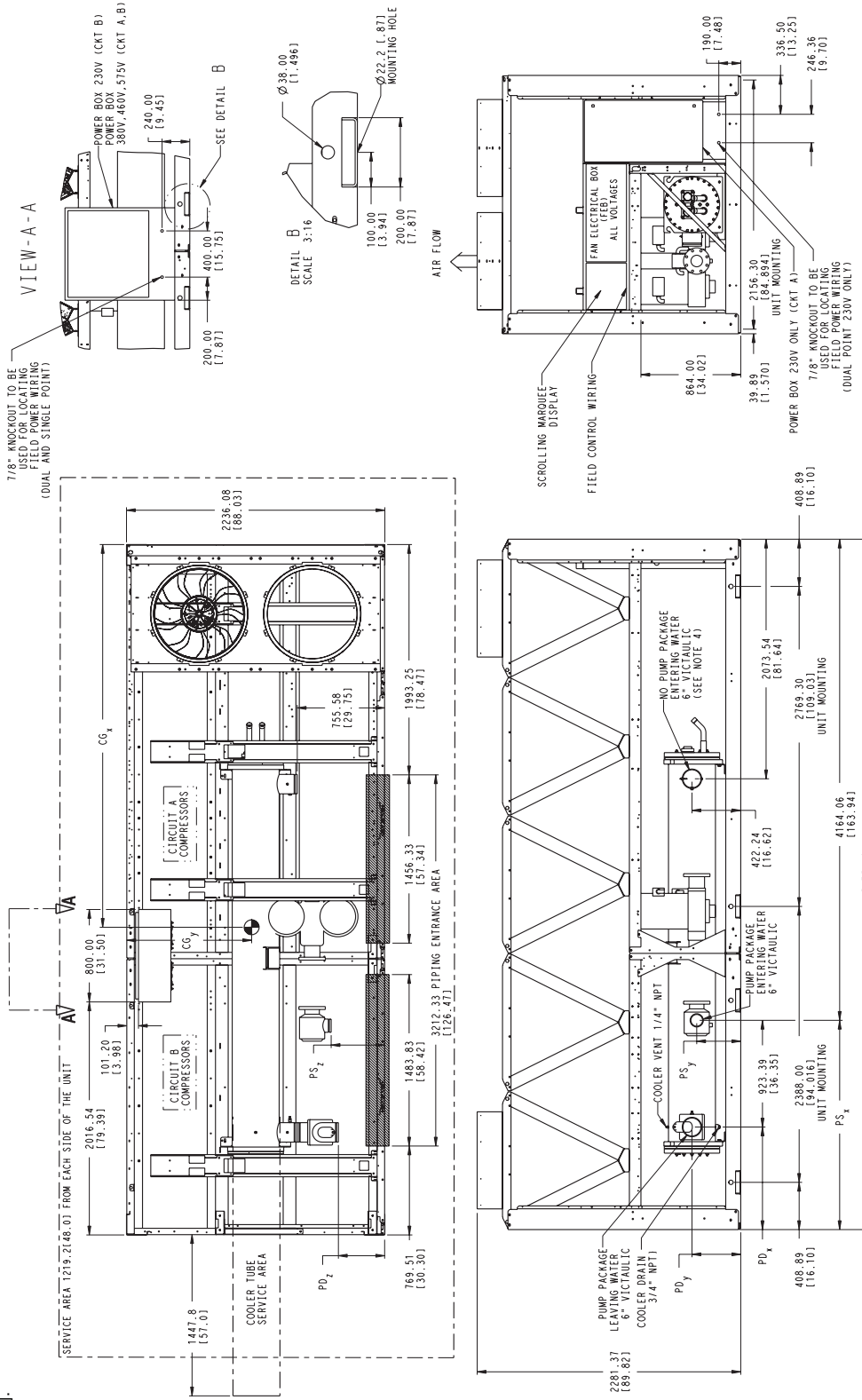
- NOTES:**
- 1. Unit must have clearances as follows:
    - Top — Do not restrict.
    - Sides and End — 6' from solid surface.
  - 2. All pumps have drains located at the bottom of volute for draining.
  - 3. Temperature relief devices located on suction line, liquid line and filter drier of each circuit and have 1/4" flare connection.
  - 4. Units without a pump package have the same leaving water connection, Y and Z dimensions, (entering water) and pump discharge X dimensions as units with a pump package.
  - 5. Dimensions are in mm [inches].



**Fig. 7 — 30RB130, 150 Air-Cooled Chiller Dimensions**

**NOTES:**

- Unit must have clearances as follows:  
 Top — Do not restrict.  
 Sides and End — 6" from solid surface.
- All pumps have drains located at the bottom of volute for draining.
- Temperature relief devices located on suction line, liquid line and filter drier of each circuit and have 1/4" flare connection.
- Units without a pump package have the same leaving water connection, Y and Z dimensions, (entering water) and pump discharge X dimensions as units with a pump package.
- Dimensions are in mm (inches).



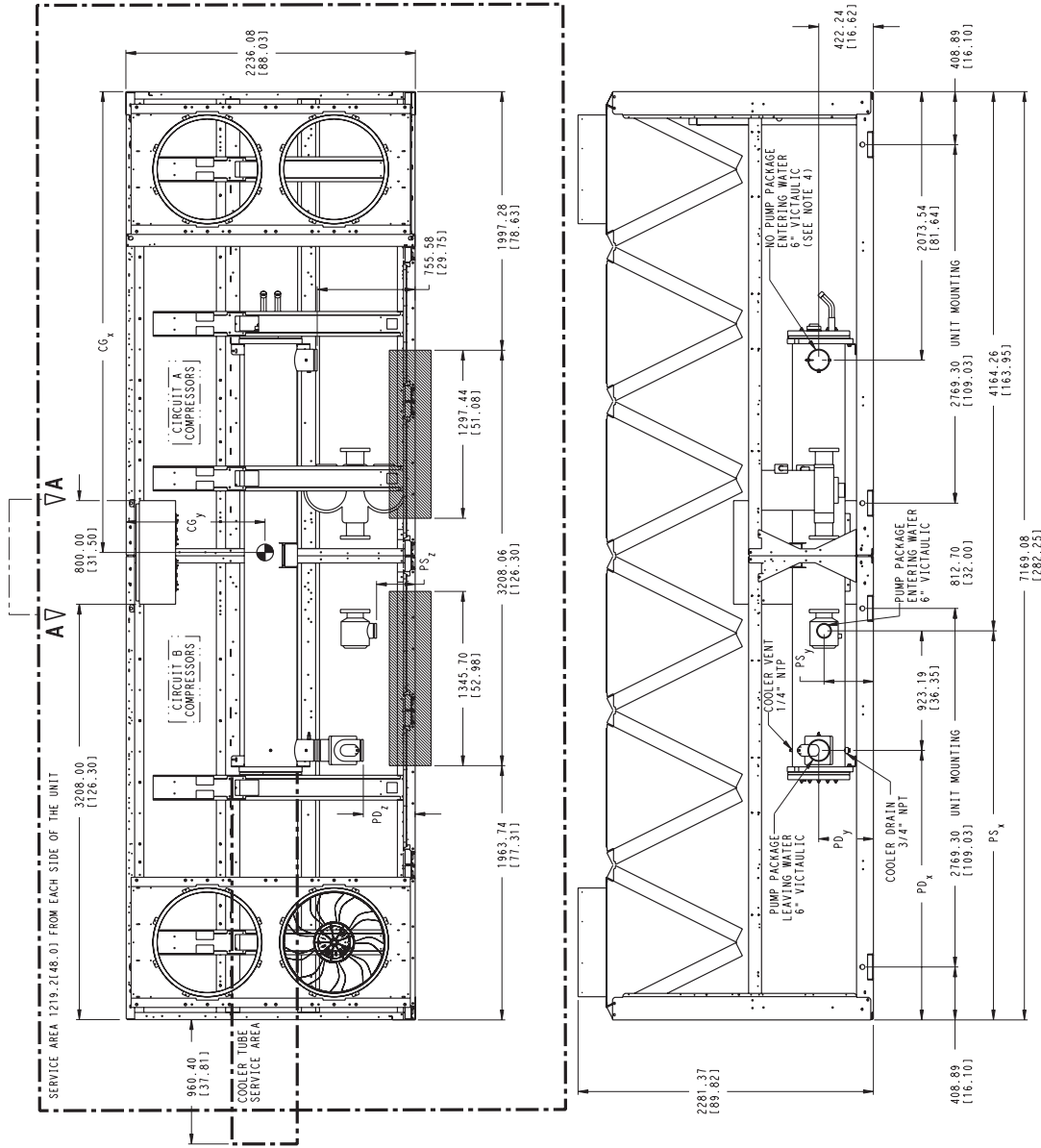
WEIGHT CU/AL lb/kg	MAX WEIGHT CU/AL lb/kg	WEIGHT MCHX lb/kg	MAX WEIGHT MCHX lb/kg	CENTER OF GRAVITY			PUMP SUCTION (FPS)			PUMP DISCHARGE (PP)			
				MM (INCH)	MM (INCH)	MM (INCH)	X ±.25	Y ±.25	Z ±.25	X ±.25	Y ±.25	Z ±.25	
9656	10000	10862	12106	8865	10109	3045	894	1808.48	381	297.2	883.32	421.64	231.14
4380	4944	4787	4951	4059	4623	1126.89	139.13	571.23	115.0	133.73	134.03	166.81	93.11
3300	3454/B, 360B	4532	5096	5079	5643	1122.59	130.53	971.2	115.0	131.71	132.21	166.61	93.11

MCHX — Microchannel Heat Exchanger

**Fig. 8 — 30RB160, 170, 315A/B, 330A/B, 345A/B, 360B Air-Cooled Chiller Dimensions**

**NOTES:**

1. Unit must have clearances as follows:
  - Top — Do not restrict
  - Sides and End — 6' from solid surface.
2. All pumps have drains located at the bottom of volute for draining.
3. Temperature relief devices located on suction line, liquid line and filter drier of each circuit and have 1/4" flare connection.
4. Dimensions are in mm [inches].



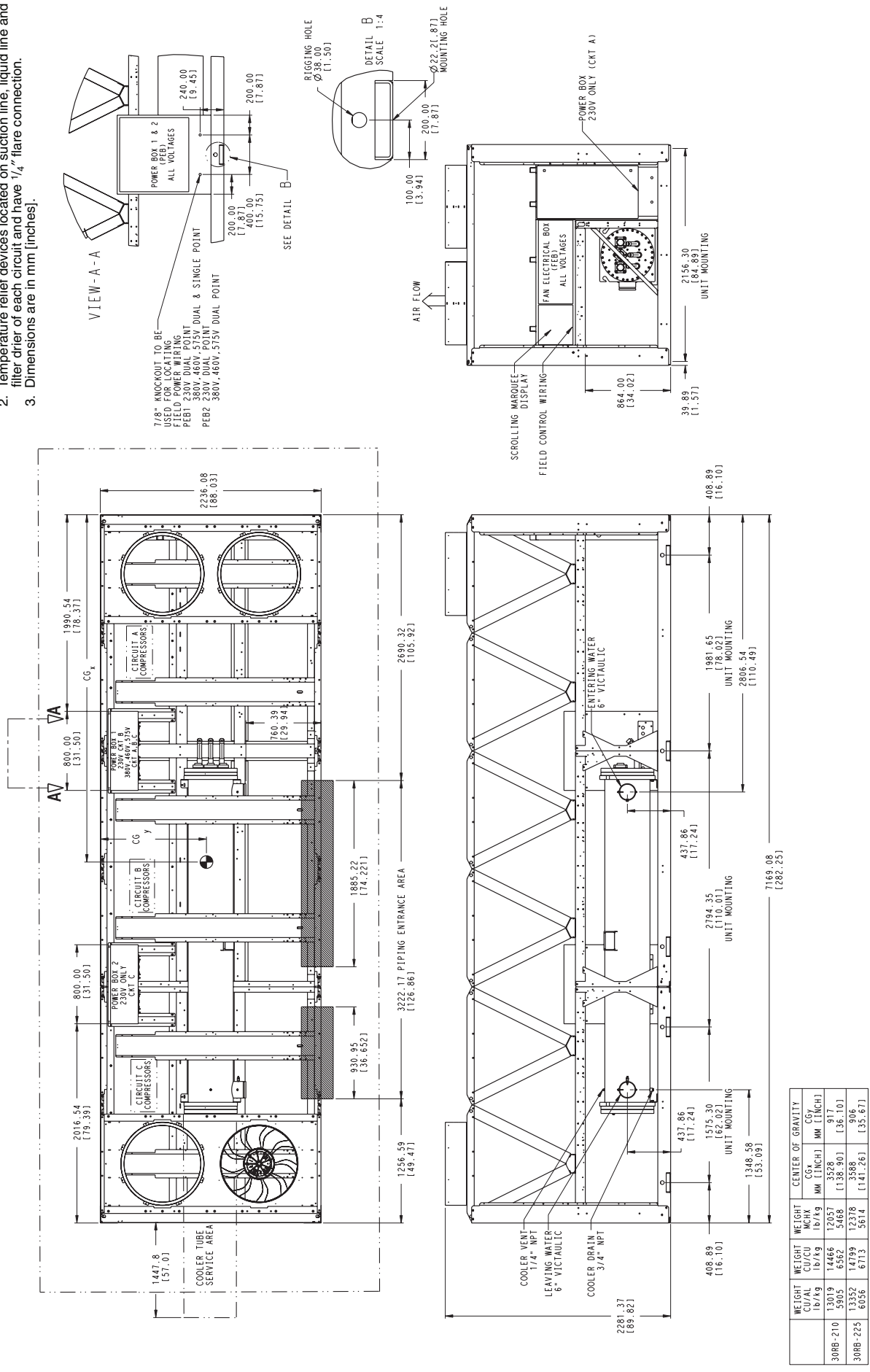
WEIGHT	MAX WEIGHT	WEIGHT	MAX WEIGHT	CENTER OF GRAVITY			PUMP SUCTION (PS)			PUMP DISCHARGE (PD)				
				CU/AL	IB/KG	MM	INCH	MM	INCH	MM	INCH	MM	INCH	
308B-190	11402	12647	12850	14094	10453	11698	3578	974	3002	381	297.2	2080.3	421.6	231.1
360A-390A/B	5172	5737	5829	6393	4741	5305	1140.87	338.35	1118.21	115.01	111.71	81.91	116.61	8.11

MCHX — Microchannel Heat Exchanger

**Fig. 9 — 30RB190, 360A, 390A/B Air-Cooled Chiller Dimensions**

**NOTES:**

1. Unit must have clearances as follows:  
Top — Do not restrict.  
Sides and End — 6' from solid surface.
2. Temperature relief devices located on suction line, liquid line and filter drier of each circuit and have 1/4" flare connection.
3. Dimensions are in mm [inches].



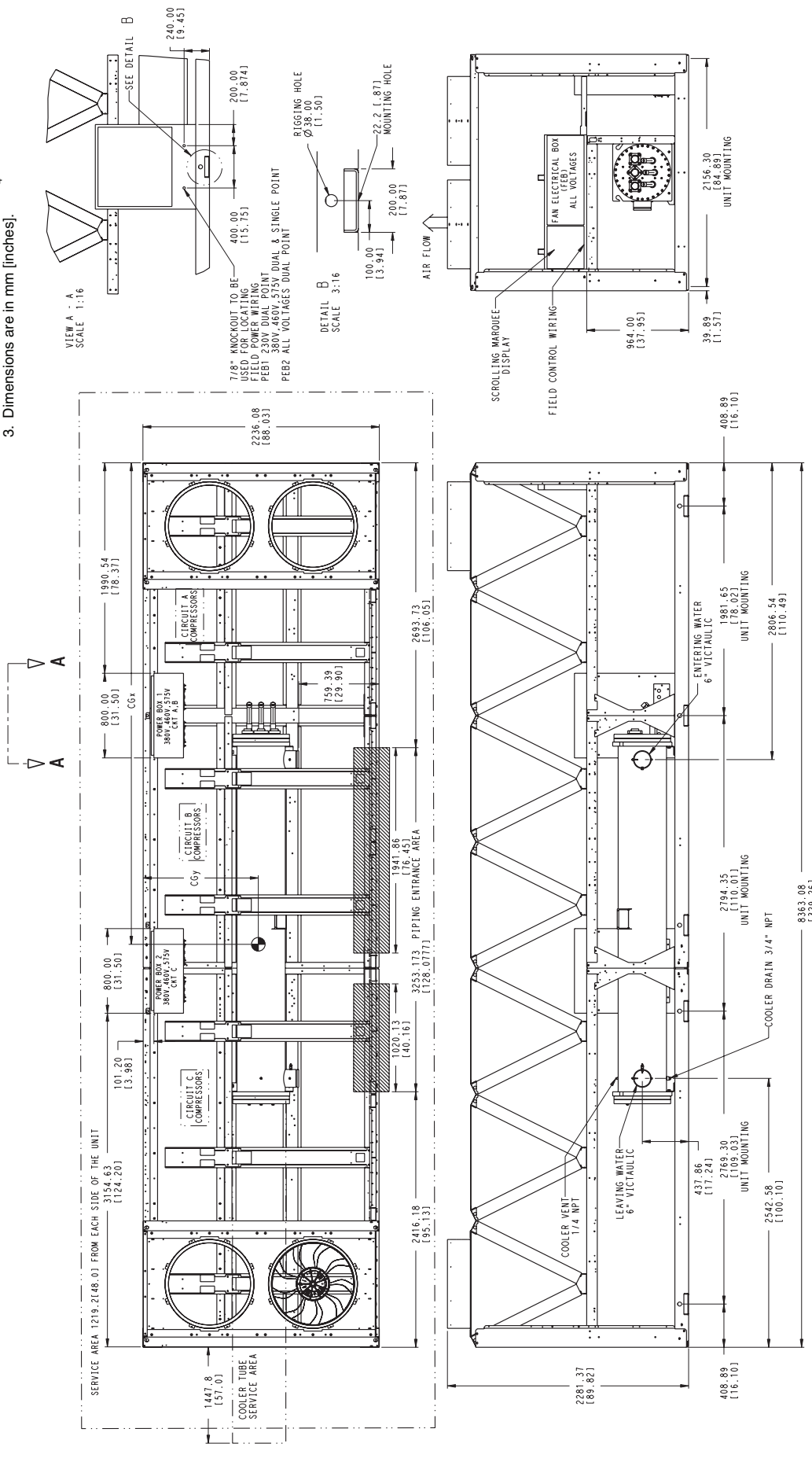
	WEIGHT		CENTER OF GRAVITY	
	CU/AL lb/kg	MCHX lb/kg	CG <sub>x</sub> MM [INCH]	CG <sub>y</sub> MM [INCH]
30RB-210	13019	14466	3528	917
	5905	6562	138.90	36.10
30RB-225	13352	14799	3588	906
	6056	6713	141.26	35.67

**MCHX — Microchannel Heat Exchanger**

**Fig. 10 — 30RB210, 225 Air-Cooled Chiller Dimensions**

NOTES:  
 1. Unit must have clearances as follows:  
 Top — Do not restrict.  
 Sides and End — 6" from solid surface.

- Temperature relief devices located on suction line, liquid line and filter drier of each circuit and have 1/4" flare connection.
- Dimensions are in mm [inches].

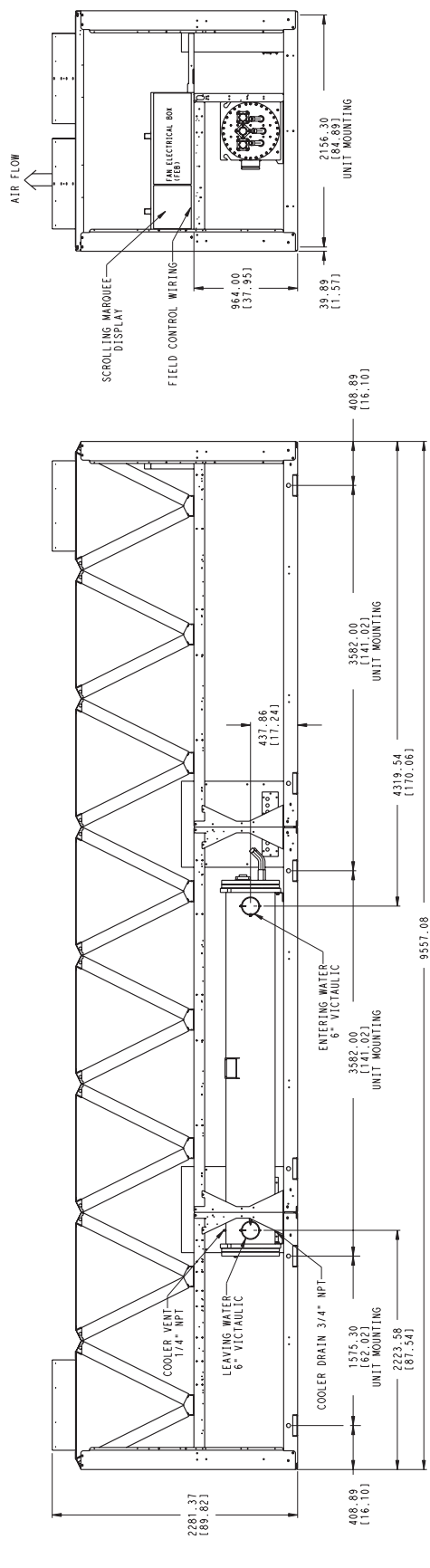
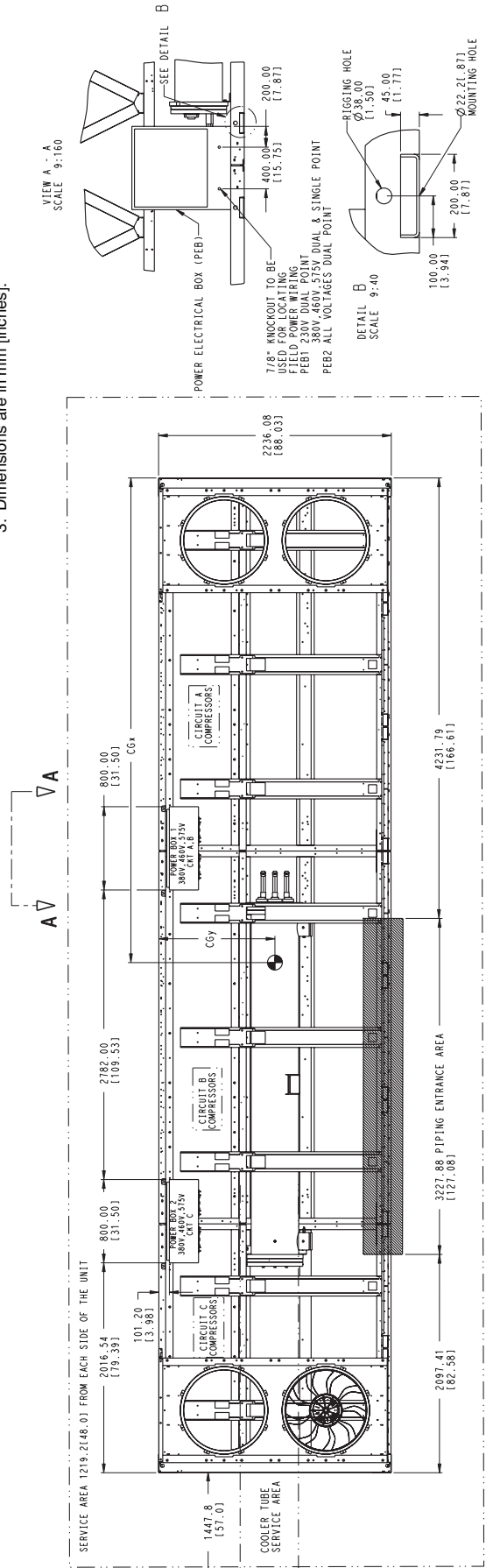


	WEIGHT		CENTER OF GRAVITY	
	lb/kg	mm	lb/kg	mm
30RB-250	1475.3	6692	1563.4	6193
			4022	158.351
			91.0	135.86

MCHX — Microchannel Heat Exchanger

Fig. 11 — 30RB250 Air-Cooled Chiller Dimensions

- NOTES:**
1. Unit must have clearances as follows:  
Top — Do not restrict.  
Sides and End — 6' from solid surface.
  2. Temperature relief devices are located on suction line. Liquid line and filter drier of each circuit and have 1/4" flare connection.
  3. Dimensions are in mm [inches].



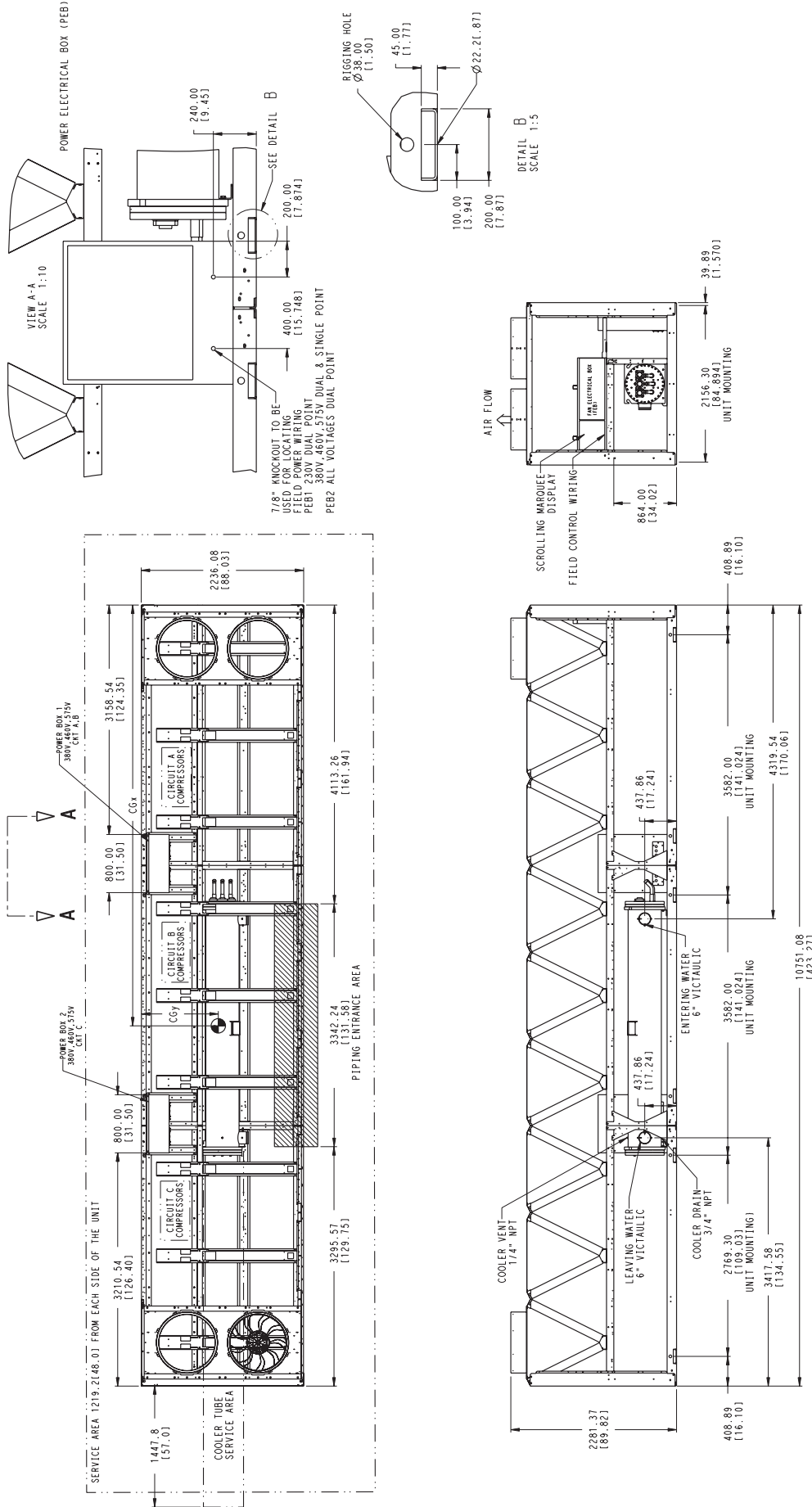
WEIGHT	WEIGHT	CENTER OF GRAVITY	
CU/KG	LB/KG	MM [INCH]	CG*
16200	18179	14332	4857
1346	8223	6172	1191.22
			91.4
			135.38

MCHX — Microchannel Heat Exchanger

Fig. 12 — 30RB275 Air-Cooled Chiller Dimensions

NOTES:  
 1. Unit must have clearances as follows:  
 Top — Do not restrict.

2. Temperature relief devices are located on suction line, liquid line and filter drier of each circuit and have 1/4" flare connection.
3. Dimensions are in mm [inches].



	WEIGHT CU/AL LB/KG	WEIGHT MCHX LB/KG	CENTER OF GRAVITY	
			CGX MM [INCH]	CGY MM [INCH]
30RB-300	17531 3919	19762 4364	5317 209.33	916 36.06

Fig. 13 — 30RB300 Air-Cooled Chiller Dimensions

MCHX — Microchannel Heat Exchanger

**AL/CU COIL UNITS WITHOUT PUMP — ENGLISH**

**AL/CU COIL UNITS WITHOUT PUMP — SI**

UNIT 30RB	MOUNTING WEIGHT (lb) No Pump Al/Cu*				
	A	B	C	D	Total
060	869	913	1193	1136	4111
070	891	936	1275	1215	4317
080	982	958	1313	1346	4600
090	1159	1397	1845	1531	5932
100	1173	1431	1952	1600	6155
110	1319	1448	1964	1788	6519
120	1626	1648	2223	2194	7690
130	1634	1763	2413	2236	8045
150	1966	1899	2609	2700	9174

UNIT 30RB	MOUNTING WEIGHT (lb) No Pump Al/Cu*						
	A	B	C	D	E	F	Total
160	1106	2189	1104	1483	2923	1463	10,266
170	1142	2220	1108	1487	3039	1606	10,601

UNIT 30RB	MOUNTING WEIGHT (lb) No Pump Al/Cu*								
	A	B	C	D	E	F	G	H	Total
190	1094	1388	1484	1101	1479	2004	1938	1526	12,013

UNIT 30RB	MOUNTING WEIGHT (lb) No Pump Al/Cu*								
	A	B	C	D	E	F	G	H	Total
210	916	1804	2139	853	1311	3044	2440	1228	13,734
225	947	1836	2144	855	1313	3049	2569	1354	14,067
250	1122	2271	2133	850	1307	3035	3166	1584	15,468
275	627	2269	2805	1292	1866	3808	3169	1080	16,915
300	899	2602	2792	1284	1859	3795	3640	1435	18,306

UNIT 30RB	MOUNTING WEIGHT (kg) No Pump Al/Cu*				
	A	B	C	D	Total
060	395	415	542	516	1869
070	405	425	580	552	1962
080	447	436	597	612	2091
090	527	635	839	696	2697
100	533	650	887	727	2798
110	600	658	893	813	2963
120	739	749	1011	997	3496
130	743	801	1097	1016	3657
150	894	863	1186	1227	4170

UNIT 30RB	MOUNTING WEIGHT (kg) No Pump Al/Cu*						
	A	B	C	D	E	F	Total
160	503	995	502	674	1328	665	4666
170	519	1009	503	676	1381	730	4819

UNIT 30RB	MOUNTING WEIGHT (kg) No Pump Al/Cu*								
	A	B	C	D	E	F	G	H	Total
190	497	631	674	500	672	911	881	694	5461

UNIT 30RB	MOUNTING WEIGHT (kg) No Pump Al/Cu*								
	A	B	C	D	E	F	G	H	Total
210	416	820	972	388	596	1384	1109	558	6243
225	431	835	975	389	597	1386	1168	615	6394
250	510	1032	970	386	594	1380	1439	720	7031
275	285	1032	1275	587	848	1731	1440	491	7689
300	409	1183	1269	584	845	1725	1654	652	8321

**CU/CU COIL UNITS WITHOUT PUMP — ENGLISH**

**CU/CU COIL UNITS WITHOUT PUMP — SI**

UNIT 30RB	MOUNTING WEIGHT (lb) No Pump Cu/Cu†				
	A	B	C	D	Total
060	992	1037	1311	1254	4,593
070	1014	1059	1393	1333	4,799
080	1106	1081	1431	1464	5,082
090	1342	1584	2020	1711	6,656
100	1355	1619	2126	1780	6,879
110	1503	1635	2139	1967	7,243
120	1841	1864	2429	2400	8,534
130	1879	2011	2647	2473	9,010
150	2213	2145	2845	2936	10,139

UNIT 30RB	MOUNTING WEIGHT (lb) No Pump Cu/Cu†						
	A	B	C	D	E	F	Total
160	1252	2497	1266	1642	3218	1599	11,472
170	1289	2528	1270	1645	3334	1742	11,807

UNIT 30RB	MOUNTING WEIGHT (lb) No Pump Cu/Cu†								
	A	B	C	D	E	F	G	H	Total
190	1257	1595	1691	1263	1638	2199	2133	1684	13,460

UNIT 30RB	MOUNTING WEIGHT (lb) No Pump Cu/Cu†								
	A	B	C	D	E	F	G	H	Total
210	1018	2045	2410	978	1427	3297	2681	1326	15,181
225	1049	2078	2415	981	1429	3301	2810	1452	15,514
250	1283	2577	2404	976	1423	3288	3463	1744	17,157
275	732	2554	3193	1501	2059	4185	3446	1175	18,845
300	1064	2950	3179	1494	2053	4172	3974	1591	20,477

UNIT 30RB	MOUNTING WEIGHT (kg) No Pump Cu/Cu†				
	A	B	C	D	Total
060	451	471	596	570	2088
070	461	481	633	606	2181
080	503	491	651	665	2310
090	610	720	918	778	3026
100	616	736	966	809	3127
110	683	743	972	894	3292
120	837	847	1104	1091	3879
130	854	914	1203	1124	4096
150	1006	975	1293	1334	4609

UNIT 30RB	MOUNTING WEIGHT (kg) No Pump Cu/Cu†						
	A	B	C	D	E	F	Total
160	569	1135	575	746	1463	727	5215
170	586	1149	577	748	1516	792	5367

UNIT 30RB	MOUNTING WEIGHT (kg) No Pump Cu/Cu†								
	A	B	C	D	E	F	G	H	Total
190	571	725	769	574	744	1000	970	765	6118

UNIT 30RB	MOUNTING WEIGHT (kg) No Pump Cu/Cu†								
	A	B	C	D	E	F	G	H	Total
210	463	930	1095	445	649	1498	1219	603	6901
225	477	944	1098	446	650	1501	1277	660	7052
250	583	1171	1093	444	647	1494	1574	793	7799
275	333	1161	1451	682	936	1902	1566	534	8566
300	484	1341	1445	679	933	1896	1807	723	9308

**MCHX COIL UNITS WITHOUT PUMP — ENGLISH**

**MCHX COIL UNITS WITHOUT PUMP — SI**

UNIT 30RB	MOUNTING WEIGHT (lb) No Pump MCHX**				
	A	B	C	D	Total
060	800	840	1098	1045	3,783
070	821	862	1175	1120	3,978
080	911	889	1218	1249	4,267
090	1065	1283	1695	1406	5,449
100	1079	1316	1796	1472	5,663
110	1219	1339	1816	1653	6,027
120	1505	1525	2058	2031	7,119
130	1503	1622	2220	2057	7,402
150	1825	1763	2422	2507	8,517

UNIT 30RB	MOUNTING WEIGHT (lb) No Pump MCHX**						
	A	B	C	D	E	F	Total
160	1020	2020	1019	1368	2698	1350	9,475
170	1055	2052	1024	1374	2809	1485	9,799

UNIT 30RB	MOUNTING WEIGHT (lb) No Pump MCHX**								
	A	B	C	D	E	F	G	H	Total
190	1007	1278	1367	1014	1362	1846	1785	1405	11,064

UNIT 30RB	MOUNTING WEIGHT (lb) No Pump MCHX**								
	A	B	C	D	E	F	G	H	Total
210	852	1677	1989	793	1219	2831	2269	1142	12,772
225	881	1709	1996	796	1222	2838	2391	1260	13,093
250	1041	2107	1979	789	1212	2815	2937	1469	14,349
275	580	2099	2594	1195	1726	3523	2931	999	15,647
300	830	2401	2576	1185	1716	3502	3359	1324	16,893

UNIT 30RB	MOUNTING WEIGHT (kg) No Pump MCHX**				
	A	B	C	D	Total
060	363	381	498	474	1716
070	372	391	533	508	1804
080	413	403	552	566	1934
090	483	582	769	638	2472
100	489	597	815	668	2569
110	553	607	824	750	2734
120	683	692	933	921	3229
130	682	736	1007	933	3358
150	828	800	1098	1137	3863

UNIT 30RB	MOUNTING WEIGHT (kg) No Pump MCHX**						
	A	B	C	D	E	F	Total
160	463	916	492	620	1224	612	4297
170	478	931	464	623	1274	673	4443

UNIT 30RB	MOUNTING WEIGHT (kg) No Pump MCHX**								
	A	B	C	D	E	F	G	H	Total
190	457	580	620	460	618	837	810	637	5019

UNIT 30RB	MOUNTING WEIGHT (kg) No Pump MCHX**								
	A	B	C	D	E	F	G	H	Total
210	386	761	902	360	553	1284	1029	518	5793
225	400	775	905	361	554	1287	1084	571	5937
250	472	956	898	358	550	1277	1332	666	6509
275	263	952	1176	542	783	1598	1329	453	7096
300	376	1089	1168	537	778	1588	1523	600	7659

\*Condenser Coil: Aluminum Fins/Copper Tubing.  
 †Condenser Coil: Copper Fins/Copper Tubing.  
 \*\* Condenser Coil: Microchannel (MCHX) Design.

**Fig. 14 — Unit Weights**



**AL/CU COIL UNITS WITH SINGLE PUMP — ENGLISH**

UNIT 30RB	MOUNTING WEIGHT (lb) Single Pump Al/Cu*				
	A	B	C	D	Total
060	1085	1127	1230	1184	4626
070	1107	1150	1312	1263	4832
080	1193	1164	1354	1388	5100
090	1353	1620	1885	1575	6432
100	1366	1655	1991	1644	6655
110	1565	1653	1974	1868	7059
120	1822	1902	2302	2204	8230
130	1827	2021	2489	2250	8585
150	2214	2178	2696	2739	9827

UNIT 30RB	MOUNTING WEIGHT (lb) Single Pump Al/Cu*						
	A	B	C	D	E	F	Total
160	1238	2583	1104	1483	3155	1357	10,919
170	1279	2609	1108	1487	3276	1495	11,254

UNIT 30RB	MOUNTING WEIGHT (lb) Single Pump Al/Cu*								
	A	B	C	D	E	F	G	H	Total
190	1094	1510	1889	1101	1479	2178	1890	1526	12,666

**CU/CU COIL UNITS WITH SINGLE PUMP — ENGLISH**

UNIT 30RB	MOUNTING WEIGHT (lb) Single Pump Cu/Cu†				
	A	B	C	D	Total
060	1208	1250	1348	1302	5,108
070	1230	1273	1430	1381	5,314
080	1317	1287	1472	1506	5,582
090	1537	1806	2060	1753	7,156
100	1549	1841	2166	1823	7,379
110	1749	1839	2150	2045	7,783
120	2037	2119	2508	2411	9,074
130	2072	2269	2723	2487	9,550
150	2461	2425	2932	2975	10,792

UNIT 30RB	MOUNTING WEIGHT (lb) Single Pump Cu/Cu†						
	A	B	C	D	E	F	Total
160	1382	2894	1266	1642	3447	1495	12,125
170	1424	2920	1270	1645	3569	1633	12,460

UNIT 30RB	MOUNTING WEIGHT (lb) Single Pump Cu/Cu†								
	A	B	C	D	E	F	G	H	Total
190	1257	1718	2095	1263	1638	2374	2084	1684	14,113

\*Condenser Coil: Aluminum Fins/Copper Tubing.  
 †Condenser Coil: Copper Fins/Copper Tubing.  
 \*\* Condenser Coil: Microchannel (MCHX) Design.

**AL/CU COIL UNITS WITH SINGLE PUMP — SI**

UNIT 30RB	MOUNTING WEIGHT (kg) Single Pump Al/Cu*				
	A	B	C	D	Total
060	493	512	559	538	2103
070	503	523	597	574	2196
080	542	529	616	631	2318
090	615	736	857	716	2924
100	621	752	905	747	3025
110	711	751	897	849	3209
120	828	865	1046	1002	3741
130	830	918	1131	1023	3902
150	1006	990	1225	1245	4467

UNIT 30RB	MOUNTING WEIGHT (kg) Single Pump Al/Cu*						
	A	B	C	D	E	F	Total
160	563	1174	502	674	1434	617	4963
170	582	1186	503	676	1489	679	5116

UNIT 30RB	MOUNTING WEIGHT (kg) Single Pump Al/Cu*								
	A	B	C	D	E	F	G	H	Total
190	497	686	858	500	672	990	859	694	5757

**CU/CU COIL UNITS WITH SINGLE PUMP — SI**

UNIT 30RB	MOUNTING WEIGHT (kg) Single Pump Cu/Cu†				
	A	B	C	D	Total
060	549	568	613	592	2322
070	559	579	650	628	2415
080	599	585	669	684	2537
090	699	821	937	797	3253
100	704	837	985	828	3354
110	795	836	977	930	3538
120	926	963	1140	1096	4125
130	942	1031	1238	1130	4341
150	1118	1102	1333	1352	4906

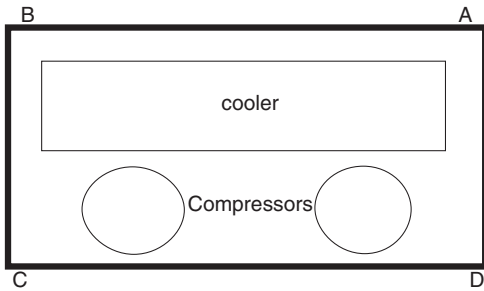
  

UNIT 30RB	MOUNTING WEIGHT (kg) Single Pump Cu/Cu†						
	A	B	C	D	E	F	Total
160	628	1315	575	746	1567	680	5511
170	647	1327	577	748	1622	742	5664

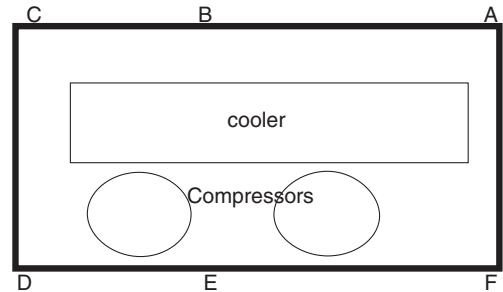
  

UNIT 30RB	MOUNTING WEIGHT (kg) Single Pump Cu/Cu†								
	A	B	C	D	E	F	G	H	Total
190	571	781	952	574	744	1079	947	765	6415

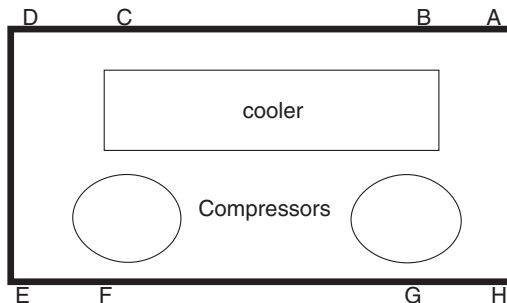
**30RB060-150**



**30RB160-170, 315A, 315B, 330A, 330B, 345A, 345B, 360B**



**30RB190-300, 360A, 390A, 390B**



NOTE: Corner weights are calculated at mounting locations. Refer to Fig. 2-13 (certified drawings) for mounting locations.

**Fig. 14 — Unit Weights (cont)**



**Table 3A — Physical Data, 30RB060-300 — English**

UNIT 30RB	060	070	080	090	100	110	120	130	150
<b>OPERATING WEIGHT (lb)*</b>									
Al-Cu Condenser Coil	4944	5150	5523	6855	7078	7442	8613	8968	10,419
Cu-Cu Condenser Coil	5426	5632	6005	7579	7802	8166	9457	9933	11,384
MCHX Condenser Coil	4616	4811	5190	6372	6586	6950	8042	8325	9762
<b>REFRIGERANT TYPE</b>	R-410A, EXV Controlled System								
Refrigerant Charge (lb)									
Std Coil, Ckt A/Ckt B/Ckt C	89.5/40.5/—	112/40.5/—	68.5/68.5/—	96/76/—	96/96/—	96/106/—	96/133/—	133/106/—	133/133/—
MCHX Coil, Ckt A/Ckt B/Ckt C	48/22/—	59/22/—	36/36/—	51/40/—	51/51/—	51/61/—	51/76/—	71/61/—	71/74/—
<b>COMPRESSORS</b>	Scroll, Hermetic								
Quantity	3	3	4	4	4	5	5	6	6
Speed (rpm)					3500				
(Qty) Compressor Model Number Ckt A	(2) SH240	(2) SH300	(2) SH240	(2) SH300	(2) SH300	(2) SH300	(2) SH300	(3) SH300	(3) SH300
(Qty) Compressor Model Number Ckt B	(1) SH240	(1) SH240	(2) SH240	(2) SH240	(2) SH300	(3) SH240	(3) SH300	(3) SH240	(3) SH300
(Qty) Compressor Model Number Ckt C	N/A	N/A	N/A	N/A	N/A	N/A	N/A	N/A	N/A
Oil Charge (Pt, Ckt A/Ckt B/Ckt C)	26.2/13.1/—	26.2/13.1/—	26.2/26.2/—	26.2/26.2/—	26.2/26.2/—	26.2/39.4/—	26.2/39.4/—	39.4/39.4/—	39.4/39.4/—
No. Capacity Steps									
Standard	3	3	4	4	4	5	5	6	6
Optional (Maximum)	4	4	5	5	5	6	6	7	7
Minimum Capacity Step (%)									
Standard	33	29	25	22	25	18	20	15	17
Optional	22	19	16	14	18	12	14	10	12
Capacity (%)									
Ckt A	67	71	50	56	50	45	40	56	50
Ckt B	33	29	50	44	50	55	60	44	50
Ckt C	N/A	N/A	N/A	N/A	N/A	N/A	N/A	N/A	N/A
<b>COOLER</b>	Direct Expansion, Shell and Tube Type								
Weight (empty, lb)	715	715	856	856	856	970	970	970	1518
Net Fluid Volume (gal)	28.2	28.2	31.3	31.3	31.3	45.8	45.8	45.8	73.5
Maximum Refrigerant Pressure (psig)	445	445	445	445	445	445	445	445	445
Maximum Fluid Side Pressure									
Without Pumps (psig)	300	300	300	300	300	300	300	300	300
Maximum Fluid Side Pressure									
With Pumps (psig)	150	150	150	150	150	150	150	150	150
<b>FLUID CONNECTIONS (in.)</b>									
Inlet and Outlet, Victaulic	4	4	4	4	4	6	6	6	6
Drain (NPT)	3/4	3/4	3/4	3/4	3/4	3/4	3/4	3/4	3/4
<b>CONDENSER FANS</b>	Shrouded Axial Type, Vertical Discharge								
Standard Low Noise Type									
Fan Speed (rpm) Standard	1140	1140	1140	1140	1140	1140	1140	1140	1140
No. Blades...Diameter (in.)	9...30	9...30	9...30	9...30	9...30	9...30	9...30	9...30	9...30
No. Fans (Ckt A/Ckt B/Ckt C)	3/1/—	3/1/—	2/2/—	3/3/—	3/3/—	3/3/—	3/4/—	4/4/—	4/4/—
Total Airflow (cfm)	49,600	49,600	49,600	74,400	74,400	74,400	86,800	99,200	99,200
<b>CONDENSER COILS</b>									
No. Coils (Ckt A/Ckt B/Ckt C)	3/1/—	3/1/—	2/2/—	3/3/—	3/3/—	3/3/—	3/4/—	4/4/—	4/4/—
Total Face Area (sq ft)	94	94	94	141	141	141	164	188	188
Max Working Refrigerant Pressure (psig)	656	656	656	656	656	656	656	656	656
<b>HYDRONIC MODULE (Optional)</b>	Pump(s) with pressure/temperature taps and combination valve.								
Pump	Single or Dual, 1800 or 3600 rpm								
<b>CHASSIS DIMENSIONS (ft-in.)</b>									
Length	7-11			11-10			15-9		
Width				7-4 <sup>25</sup> / <sub>32</sub>					
Height				7-6 <sup>7</sup> / <sub>16</sub>					

**LEGEND**

- Al — Aluminum
- Cu — Copper
- EXV — Electronic Expansion Valve
- MCHX — Microchannel Heat Exchanger
- N/A — Not Applicable

\*Operating weight includes 2 pumps on Models 30RB060-190. Pump packages are not available on models larger than 30RB190.

**Table 3A — Physical Data, 30RB060-300 — English (cont)**

UNIT 30RB	160	170	190	210	225	250	275	300
<b>OPERATING WEIGHT (lb)*</b>								
AI-Cu Condenser Coil	11,511	11,846	13,258	13,734	14,067	15,468	16,915	18,306
Cu-Cu Condenser Coil	12,717	13,052	14,705	15,181	15,514	17,157	18,845	20,477
MCHX Condenser Coil	10,720	11,044	12,309	12,772	13,093	14,349	15,647	16,893
<b>REFRIGERANT TYPE</b>	R-410A, EXV Controlled System							
Refrigerant Charge (lb)								
Std Coil, Ckt A/Ckt B/Ckt C	162/106/—	162/133/—	162/162/—	133/106/133	133/133/133	133/133/162	162/162/133	162/162/162
MCHX Coil, Ckt A/Ckt B/Ckt C	86/61/—	86/77/—	86/93/—	71/61/82	71/76/82	71/76/100	86/93/82	86/93/100
<b>COMPRESSORS</b>	Scroll, Hermetic							
Quantity	7	7	8	9	9	10	11	12
Speed (rpm)					3500			
(Qty) Compressor Model Number Ckt A	(4) SH300	(4) SH300	(4) SH300	(3) SH300	(3) SH300	(3) SH300	(4) SH300	(4) SH300
(Qty) Compressor Model Number Ckt B	(3) SH240	(3) SH300	(4) SH300	(3) SH240	(3) SH300	(3) SH300	(4) SH300	(4) SH300
(Qty) Compressor Model Number Ckt C	N/A	N/A	N/A	(3) SH300	(3) SH300	(4) SH300	(3) SH300	(4) SH300
Oil Charge (Pt, Ckt A/Ckt B/Ckt C)	52.5/39.4/—	52.5/39.4/—	52.5/52.5/—	39.4/39.4/39.4	39.4/39.4/39.4	39.4/39.4/52.5	52.5/52.5/39.4	52.5/52.5/52.5
No. Capacity Steps								
Standard	7	7	8	9	9	10	11	12
Optional (Maximum)	8	8	9	10	10	11	12	13
Minimum Capacity Step (%)								
Standard	13	14	13	10	11	10	9	8
Optional	8	10	9	6	8	7	7	6
Capacity (%)								
Ckt A	62	57	50	36	33	30	36	33
Ckt B	38	43	50	28	33	30	36	33
Ckt C	N/A	N/A	N/A	36	33	40	28	33
<b>COOLER</b>	Direct Expansion, Shell and Tube Type							
Weight (empty, lb)	1518	1518	1518	2382	2382	2382	2382	2382
Net Fluid Volume (gal)	73.5	73.5	73.5	86.6	86.6	86.6	86.6	86.6
Maximum Refrigerant Pressure (psig)	445	445	445	445	445	445	445	445
Maximum Fluid Side Pressure								
Without Pumps (psig)	300	300	300	300	300	300	300	300
Maximum Fluid Side Pressure								
With Pumps (psig)	150	150	150	150	150	150	150	150
<b>FLUID CONNECTIONS (in.)</b>								
Inlet and Outlet, Victaulic	6	6	6	6	6	6	6	6
Drain (NPT)	3/4	3/4	3/4	3/4	3/4	3/4	3/4	3/4
<b>CONDENSER FANS</b>	Shrouded Axial Type, Vertical Discharge							
Standard Low Noise Type								
Fan Speed (rpm) Standard	1140	1140	1140	1140	1140	1140	1140	1140
No. Blades...Diameter (in.)	9...30	9...30	9...30	9...30	9...30	9...30	9...30	9...30
No. Fans (Ckt A/Ckt B/Ckt C)	6/4/—	6/4/—	6/6/—	4/4/4	4/4/4	4/4/6	6/6/4	6/6/6
Total Airflow (cfm)	124,000	124,000	148,800	148,800	148,800	173,600	198,400	223,200
<b>CONDENSER COILS</b>								
No. Coils (Ckt A/Ckt B/Ckt C)	6/4/—	6/4/—	6/6/—	4/4/4	4/4/4	4/4/6	6/6/4	6/6/6
Total Face Area (sq ft)	235	235	282	282	282	328	375	422
Max Working Refrigerant Pressure (psig)	656	656	656	656	656	656	656	656
<b>HYDRONIC MODULE (Optional)</b>	Pump(s) with pressure/temperature taps and combination valve.							
Pump	Single or Dual, 1800 or 3600 rpm				Not available			
<b>CHASSIS DIMENSIONS (ft-in.)</b>								
Length	19-8		23-7			27-6	31-5	35-4
Width	7-4 <sup>25</sup> / <sub>32</sub>							
Height	7-6 <sup>7</sup> / <sub>16</sub>							

**LEGEND**

- AI — Aluminum
- Cu — Copper
- EXV — Electronic Expansion Valve
- MCHX — Microchannel Heat Exchanger
- N/A — Not Applicable

\*Operating weight includes 2 pumps on Models 30RB060-190. Pump packages are not available on models larger than 30RB190.

**Table 3B — Physical Data, 30RB060-300 — SI**

UNIT 30RB	060	070	080	090	100	110	120	130	150
<b>OPERATING WEIGHT (kg)*</b>									
Al-Cu Condenser Coil	2242	2336	2505	3109	3210	3375	3906	4067	4725
Cu-Cu Condenser Coil	2461	2554	2723	3437	3538	3703	4289	4505	5163
MCHX Condenser Coil	2093	2182	2354	2890	2987	3152	3647	3776	4427
<b>REFRIGERANT TYPE</b>	R-410A, EXV Controlled System								
Refrigerant Charge (kg)									
Std Coil, Ckt A/Ckt B/Ckt C	40.6/18.4/—	50.8/18.4/—	31.1/31.1/—	43.5/34.5/—	43.5/43.5/—	43.5/48.1/—	43.5/60.3/—	60.3/48.1/—	60.3/60.3/—
MCHX Coil, Ckt A/Ckt B/Ckt C	21.8/10.0/—	26.8/10.0/—	16.3/16.3/—	23.1/18.1/—	23.1/23.1/—	23.1/27.7/—	23.1/34.5/—	32.2/27.7/—	32.2/33.6/—
<b>COMPRESSORS</b>	Scroll, Hermetic								
Quantity	3	3	4	4	4	5	5	6	6
Speed (r/s)					58.3				
(Qty) Compressor Model Number Ckt A	(2) SH240	(2) SH300	(2) SH240	(2) SH300	(2) SH300	(2) SH300	(2) SH300	(3) SH300	(3) SH300
(Qty) Compressor Model Number Ckt B	(1) SH240	(1) SH240	(2) SH240	(2) SH240	(2) SH300	(3) SH240	(3) SH300	(3) SH240	(3) SH300
(Qty) Compressor Model Number Ckt C	N/A	N/A	N/A	N/A	N/A	N/A	N/A	N/A	N/A
Oil Charge (L, Ckt A/Ckt B/Ckt C)	12.4/6.2/—	12.4/6.2/—	12.4/12.4/—	12.4/12.4/—	12.4/12.4/—	12.4/18.6/—	12.4/18.6/—	18.6/18.6/—	18.6/18.6/—
No. Capacity Steps									
Standard	3	3	4	4	4	5	5	6	6
Optional (Maximum)	4	4	5	5	5	6	6	7	7
Minimum Capacity Step (%)									
Standard	33	29	25	22	25	18	20	15	17
Optional	22	19	16	14	18	12	14	10	12
Capacity (%)									
Ckt A	67	71	50	56	50	45	40	56	50
Ckt B	33	29	50	44	50	55	60	44	50
Ckt C	N/A	N/A	N/A	N/A	N/A	N/A	N/A	N/A	N/A
<b>COOLER</b>	Direct Expansion, Shell and Tube Type								
Weight (empty, kg)	324	324	388	388	388	440	440	440	689
Net Fluid Volume (L)	106	106	118	118	118	173	173	173	278
Maximum Refrigerant Pressure (kPa)	3068	3068	3068	3068	3068	3068	3068	3068	3068
Maximum Fluid Side Pressure Without Pumps (kPa)	2068	2068	2068	2068	2068	2068	2068	2068	2068
Maximum Fluid Side Pressure With Pumps (kPa)	1034	1034	1034	1034	1034	1034	1034	1034	1034
<b>FLUID CONNECTIONS (in.)</b>									
Inlet and Outlet, Victaulic	4	4	4	4	4	6	6	6	6
Drain (NPT)	3/4	3/4	3/4	3/4	3/4	3/4	3/4	3/4	3/4
<b>CONDENSER FANS</b>	Shrouded Axial Type, Vertical Discharge								
Standard Low Noise Type									
Fan Speed (r/s) Standard	19	19	19	19	19	19	19	19	19
No. Blades...Diameter (mm)	9...762	9...762	9...762	9...762	9...762	9...762	9...762	9...762	9...762
No. Fans (Ckt A/Ckt B/Ckt C)	3/1/—	3/1/—	2/2/—	3/3/—	3/3/—	3/3/—	3/4/—	4/4/—	4/4/—
Total Airflow (L/s)	23 409	23 409	23 409	35 113	35 113	35 113	40 965	46 817	46 817
<b>CONDENSER COILS</b>									
No. Coils (Ckt A/Ckt B/Ckt C)	3/1/—	3/1/—	2/2/—	3/3/—	3/3/—	3/3/—	3/4/—	4/4/—	4/4/—
Total Face Area (sq m)	8.73	8.73	8.73	13.1	13.1	13.1	15.24	17.47	17.47
Max Working Refrigeration Pressure (kPa)	4522	4522	4522	4522	4522	4522	4522	4522	4522
<b>HYDRONIC MODULE (Optional)</b>	Pump(s) with pressure/temperature taps and combination valve.								
Pump	Single or Dual, 29.2 or 58.3 r/s								
<b>CHASSIS DIMENSIONS</b>									
Length (mm)	2412			3606			4800		
Width (mm)	2255								
Height (mm)	2296.9								

**LEGEND**

- Al — Aluminum
- Cu — Copper
- EXV — Electronic Expansion Valve
- MCHX — Microchannel Heat Exchanger
- N/A — Not Applicable

\*Operating weight includes 2 pumps on Models 30RB060-190. Pump packages are not available on models larger than 30RB190.

**Table 3B — Physical Data, 30RB060-300 — SI (cont)**

UNIT 30RB	160	170	190	210	225	250	275	300
<b>OPERATING WEIGHT (kg)*</b>								
Al-Cu Condenser Coil	5220	5372	6013	6228	6379	7015	7671	8302
Cu-Cu Condenser Coil	5767	5919	6669	6885	7036	7781	8546	9286
MCHX Condenser Coil	4862	5009	5582	5792	5938	6507	7096	7661
<b>REFRIGERANT TYPE</b>	R-410A, EXV Controlled System							
Refrigerant Charge (kg)								
Std Coil, Ckt A/Ckt B/Ckt C	73.5/48.1/— 39.0/27.7/—	73.5/60.3/— 39.0/34.9/—	73.5/73.5/— 39.0/42.2/—	60.3/48.1/60.3 32.2/27.7/37.2	60.3/60.3/60.3 32.2/34.5/37.2	60.3/60.3/73.5 32.2/34.5/45.4	73.5/73.5/60.3 39.0/42.2/37.2	73.5/73.5/73.5 39.0/42.2/45.4
<b>COMPRESSORS</b>	Scroll, Hermetic							
Quantity	7	7	8	9	9	10	11	12
Speed (r/s)					58.3			
(Qty) Compressor Model Number Ckt A	(4) SH300	(4) SH300	(4) SH300	(3) SH300	(3) SH300	(3) SH300	(4) SH300	(4) SH300
(Qty) Compressor Model Number Ckt B	(3) SH240	(3) SH300	(4) SH300	(3) SH240	(3) SH300	(3) SH300	(4) SH300	(4) SH300
(Qty) Compressor Model Number Ckt C	N/A	N/A	N/A	(3) SH300	(3) SH300	(4) SH300	(3) SH300	(4) SH300
Oil Charge (L, Ckt A/Ckt B/Ckt C)	24.8/18.6/—	24.8/18.6/—	24.8/24.8/—	18.6/18.6/18.6	18.6/18.6/18.6	18.6/18.6/24.8	24.8/24.8/18.6	24.8/24.8/24.8
No. Capacity Steps								
Standard	7	7	8	9	9	10	11	12
Optional (Maximum)	8	8	9	10	10	11	12	13
Minimum Capacity Step (%)								
Standard	13	14	13	10	11	10	9	8
Optional	8	10	9	6	8	7	7	6
Capacity (%)								
Ckt A	62	57	50	38	33	30	36	33
Ckt B	38	43	50	28	33	30	36	33
Ckt C	N/A	N/A	N/A	36	33	40	28	33
<b>COOLER</b>	Direct Expansion, Shell and Tube Type							
Weight (empty, kg)	689	689	689	1080	1080	1080	1080	1080
Net Fluid Volume (L)	278	278	278	327	327	327	327	327
Maximum Refrigerant Pressure (psig)	3068	3068	3068	3068	3068	3068	3068	3068
Maximum Fluid Side Pressure								
Without Pumps (psig)	2068	2068	2068	2068	2068	2068	2068	2068
Maximum Fluid Side Pressure								
With Pumps (psig)	1034	1034	1034	1034	1034	1034	1034	1034
<b>FLUID CONNECTIONS (in.)</b>								
Inlet and Outlet, Victaulic	6	6	6	6	6	6	6	6
Drain (NPT)	3/4	3/4	3/4	3/4	3/4	3/4	3/4	3/4
<b>CONDENSER FANS</b>	Shrouded Axial Type, Vertical Discharge							
Standard Low Noise Type								
Fan Speed (r/s) Standard	19	19	19	19	19	19	19	19
No. Blades...Diameter (mm)	9...762	9...762	9...762	9...762	9...762	9...762	9...762	9...762
No. Fans (Ckt A/Ckt B/Ckt C)	6/4/—	6/4/—	6/6/—	4/4/4	4/4/4	4/4/6	6/6/4	6/6/6
Total Airflow (L/s)	58 521	58 521	70 226	70 226	70 226	81 930	93 634	105 339
<b>CONDENSER COILS</b>								
No. Coils (Ckt A/Ckt B/Ckt C)	6/4/—	6/4/—	6/6/—	4/4/4	4/4/4	4/4/6	6/6/4	6/6/6
Total Face Area (sq m)	21.83	21.83	26.2	26.2	26.2	30.47	34.84	39.21
Max Working Refrigeration Pressure (kPa)	4522	4522	4522	4522	4522	4522	4522	4522
<b>HYDRONIC MODULE (Optional)</b>	Pump(s) with pressure/temperature taps and combination valve. Single or Dual, 29.2 or 58.3 r/s				Not available			
Pump					Not available			
<b>CHASSIS DIMENSIONS</b>								
Length (mm)	5994	5994	7188	7188	7188	8382	9576	10 770
Width (mm)					2255			
Height (mm)					2296.9			

**LEGEND**

- Al — Aluminum
- Cu — Copper
- EXV — Electronic Expansion Valve
- MCHX — Microchannel Heat Exchanger
- N/A — Not Applicable

\*Operating weight includes 2 pumps on Models 30RB060-190. Pump packages are not available on models larger than 30RB190.

**Table 4A — Physical Data — 30RB315-390 — English**

UNIT 30RB	315	330	345	360	390
<b>OPERATING WEIGHT (Module A/Module B, lb)*</b>					
Al-Cu Condenser Coil	10,266/10,266	10,601/10,266	10,601/10,601	12,013/10,601	12,013/12,013
Cu-Cu Condenser Coil	11,472/11,472	11,807/11,472	11,807/11,807	13,460/11,807	13,460/13,460
MCHX Condenser Coil	9,475/9,475	9,799/9,475	9,799/9,799	11,064/9,799	11,064/11,064
<b>REFRIGERANT TYPE</b>	R-410A, EXV Controlled System				
Circuits Qty	4	4	4	4	4
Refrigerant Charge					
Std Coil, Module A Ckt A/Ckt B (lb)	162/106	162/133	162/133	162/162	162/162
Std Coil, Module B Ckt A/Ckt B (lb)	162/106	162/106	162/133	162/133	162/162
MCHX Coil, Module A Ckt A/Ckt B (lb)	86/61	86/77	86/77	86/93	86/93
MCHX Coil, Module B Ckt A/Ckt B (lb)	86/61	86/61	86/77	86/77	86/93
<b>COMPRESSORS</b>	Scroll, Hermetic				
Total Quantity	14	14	14	15	16
Speed (rpm)			3500		
Module A, (Qty) Compressor Model Number Ckt A	(4) SH300	(4) SH300	(4) SH300	(4) SH300	(4) SH300
Module A, (Qty) Compressor Model Number Ckt B	(3) SH240	(3) SH300	(3) SH300	(4) SH300	(4) SH300
Module B, (Qty) Compressor Model Number Ckt A	(4) SH300	(4) SH300	(4) SH300	(4) SH300	(4) SH300
Module B, (Qty) Compressor Model Number Ckt B	(3) SH240	(3) SH240	(3) SH300	(3) SH300	(4) SH300
Module A Oil Charge (Pt, Ckt A/Ckt B)	52.5/39.4	52.5/39.4	52.5/39.4	52.5/52.5	52.5/52.5
Module B Oil Charge (Pt, Ckt A/Ckt B)	52.5/39.4	52.5/39.4	52.5/39.4	52.5/39.4	52.5/52.5
No. Capacity Steps					
Standard	14	14	14	15	16
Optional (Maximum)	16	16	16	17	18
Minimum Capacity Step (%)					
Standard	6	6	7	7	6
Optional	5	4	6	5	5
Capacity (%)					
Module A, Ckt A	31	30	29	27	25
Module A, Ckt B	19	22	21	27	25
Module B, Ckt A	31	30	29	27	25
Module B, Ckt B	19	18	21	20	25
<b>COOLER</b>	Direct Expansion, Shell and Tube Type				
Module A Weight (empty, lb)	1518	1518	1518	1518	1518
Module B Weight (empty, lb)	1518	1518	1518	1518	1518
Net Fluid Volume (gal) Module A/Module B	73.5/73.5	73.5/73.5	73.5/73.5	73.5/73.5	73.5/73.5
Maximum Refrigerant Pressure (psig)	445	445	445	445	445
Maximum Fluid Side Pressure (psig)	300	300	300	300	300
<b>FLUID CONNECTIONS (in.)</b>					
Inlet and Outlet, Victaulic	6	6	6	6	6
Drain (NPT)	3/4	3/4	3/4	3/4	3/4
<b>CONDENSER FANS</b>	Shrouded Axial Type, Vertical Discharge				
Standard Low Noise Type					
Fan Speed (rpm) Standard	1140	1140	1140	1140	1140
Module A No. Blades...Diameter (in.) Ckt A/Ckt B	9...30/9...30	9...30/9...30	9...30/9...30	9...30/9...30	9...30/9...30
Module B No. Blades...Diameter (in.) Ckt A/Ckt B	9...30/9...30	9...30/9...30	9...30/9...30	9...30/9...30	9...30/9...30
Total No. Fans	20	20	20	22	24
Module A No. Fans (Ckt A/Ckt B)	6/4	6/4	6/4	6/6	6/6
Module B No. Fans (Ckt A/Ckt B)	6/4	6/4	6/4	6/4	6/6
Total Airflow (cfm)	248,000	248,000	248,000	272,800	297,600
<b>CONDENSER COILS</b>					
Module A No. Coils (Ckt A/Ckt B)	6/4	6/4	6/4	6/6	6/6
Module B No. Coils (Ckt A/Ckt B)	6/4	6/4	6/4	6/4	6/6
Total Face Area (sq ft)	470	470	470	517	564
Max Working Refrigerant Pressure (psig)	656	656	656	656	656

LEGEND

- Al — Aluminum
- Cu — Copper
- EXV — Electronic Expansion Valve
- MCHX — Microchannel Heat Exchanger

\*Pump packages are not available for models 30RB315-390.

**Table 4B — Physical Data — 30RB315-390 — SI**

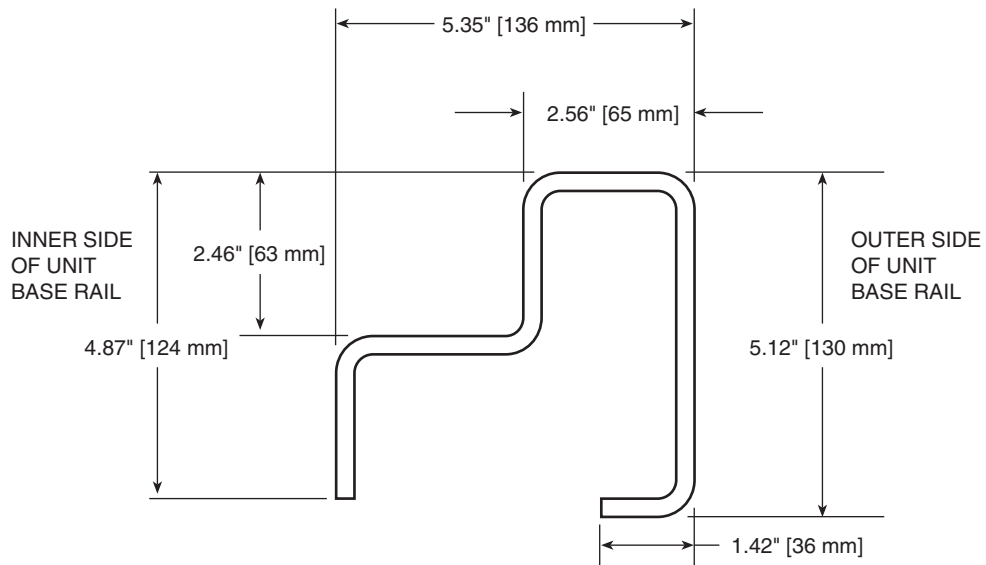
UNIT 30RB	315	330	345	360	390
<b>OPERATING WEIGHT (Module A/Module B, kg)*</b>					
Al-Cu Condenser Coil	4656/4656	4808/4656	4808/4808	5448/4808	5448/5448
Cu-Cu Condenser Coil	5203/5203	5354/5203	5354/5354	6104/5354	6104/6104
MCHX Condenser Coil	4297/4297	4444/4297	4444/4444	5018/4444	5018/5018
<b>REFRIGERANT TYPE</b>	R-410A, EXV Controlled System				
Circuits Qty	4	4	4	4	4
Refrigerant Charge					
Std Coil, Module A Ckt A/Ckt B (kg)	73.5/48.1	73.5/60.3	73.5/60.3	73.5/73.5	73.5/73.5
Std Coil, Module B Ckt A/Ckt B (kg)	73.5/48.1	73.5/48.1	73.5/60.3	73.5/60.3	73.5/73.5
MCHX Coil, Module A Ckt A/Ckt B (kg)	39.0/27.7	39.0/34.9	39.0/34.9	39.0/42.2	39.0/42.2
MCHX Coil, Module B Ckt A/Ckt B (kg)	39.0/27.7	39.0/27.7	39.0/34.9	39.0/34.9	39.0/42.2
<b>COMPRESSORS</b>	Scroll, Hermetic				
Total Quantity	14	14	14	15	16
Speed (r/s)			58.3		
Module A, (Qty) Compressor Model Number (ton) Ckt A	(4) SH300	(4) SH300	(4) SH300	(4) SH300	(4) SH300
Module A, (Qty) Compressor Model Number (ton) Ckt B	(3) SH240	(3) SH300	(3) SH300	(4) SH300	(4) SH300
Module B, (Qty) Compressor Model Number (ton) Ckt A	(4) SH300	(4) SH300	(4) SH300	(4) SH300	(4) SH300
Module B, (Qty) Compressor Model Number (ton) Ckt B	(3) SH240	(3) SH240	(3) SH300	(3) SH300	(4) SH300
Module A Oil Charge (L, CktA/CktB)	52.5/39.4	52.5/39.4	52.5/39.4	52.5/52.5	52.5/52.5
Module B Oil Charge (L, CktA/CktB)	52.5/39.4	52.5/39.4	52.5/39.4	52.5/39.4	52.5/52.5
No. Capacity Steps					
Standard	14	14	14	15	16
Optional (Maximum)	16	16	16	17	18
Minimum Capacity Step (%)					
Standard	6	6	7	7	6
Optional	5	4	6	5	5
Capacity (%)					
Module A, Ckt A	31	30	29	27	25
Module A, Ckt B	19	22	21	27	25
Module B, Ckt A	31	30	29	27	25
Module B, Ckt B	19	18	21	20	25
<b>COOLER</b>	Direct Expansion, Shell and Tube Type				
Module A Weight (empty, kg)	689	689	689	689	689
Module B Weight (empty, kg)	689	689	689	689	689
Net Fluid Volume (L) Module A/Module B	278/278	278/278	278/278	278/278	278/278
Maximum Refrigerant Pressure (kPa)	3068	3068	3068	3068	3068
Maximum Fluid Side Pressure (kPa)	2068	2068	2068	2068	2068
<b>FLUID CONNECTIONS (in.)</b>					
Inlet and Outlet, Victaulic	6	6	6	6	6
Drain (NPT)	3/4	3/4	3/4	3/4	3/4
<b>CONDENSER FANS</b>	Shrouded Axial Type, Vertical Discharge				
Standard Low Noise Type					
Fan Speed (r/s) Standard	19	19	19	19	19
Module A No. Blades...Diameter (mm.) Ckt A/Ckt B	9...762/9...762	9...762/9...762	9...762/9...762	9...762/9...762	9...762/9...762
Module B No. Blades...Diameter (mm.) Ckt A/Ckt B	9...762/9...762	9...762/9...762	9...762/9...762	9...762/9...762	9...762/9...762
Total No. Fans	20	20	20	22	24
Module A No. Fans (Ckt A/Ckt B)	6/4	6/4	6/4	6/6	6/6
Module B No. Fans (Ckt A/Ckt B)	6/4	6/4	6/4	6/4	6/6
Total Airflow (L/s)	117 042	117 042	117 042	128 747	140 452
<b>CONDENSER COILS</b>					
Module A No. Coils (Ckt A/Ckt B)	6/4	6/4	6/4	6/6	6/6
Module B No. Coils (Ckt A/Ckt B)	6/4	6/4	6/4	6/4	6/6
Total Face Area (sq m)	43.66	43.66	43.66	48.03	52.4
Max Working Refrigerant Pressure (kPa)	4522	4522	4522	4522	4522

**LEGEND**

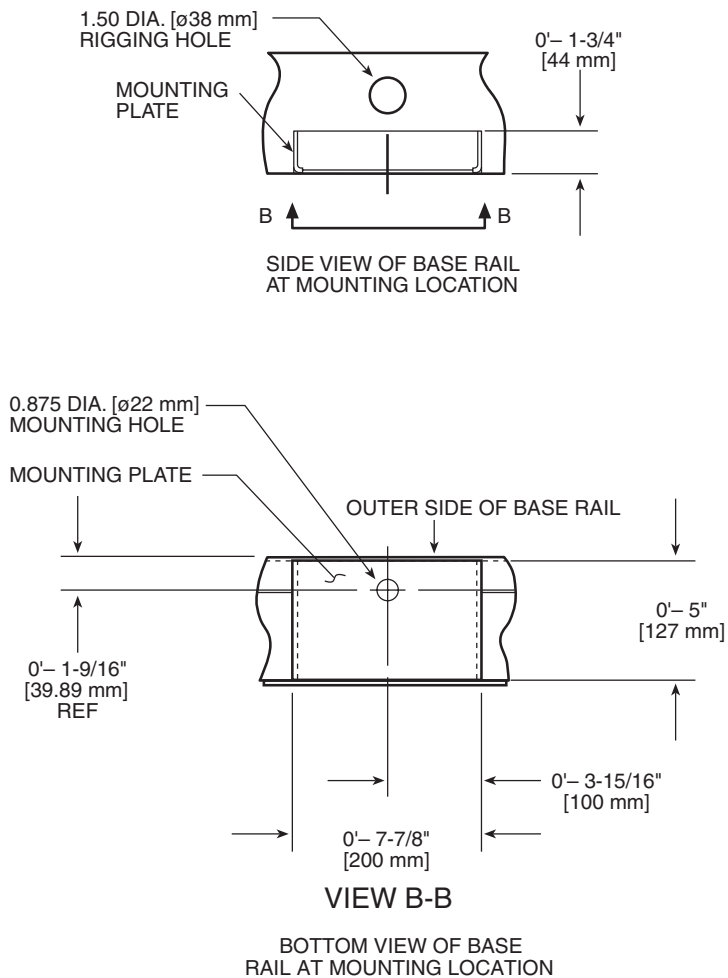
- Al** — Aluminum
- Cu** — Copper
- EXV** — Electronic Expansion Valve
- MCHX** — Microchannel Heat Exchanger

\*Pump packages are not available for models 30RB315-390.

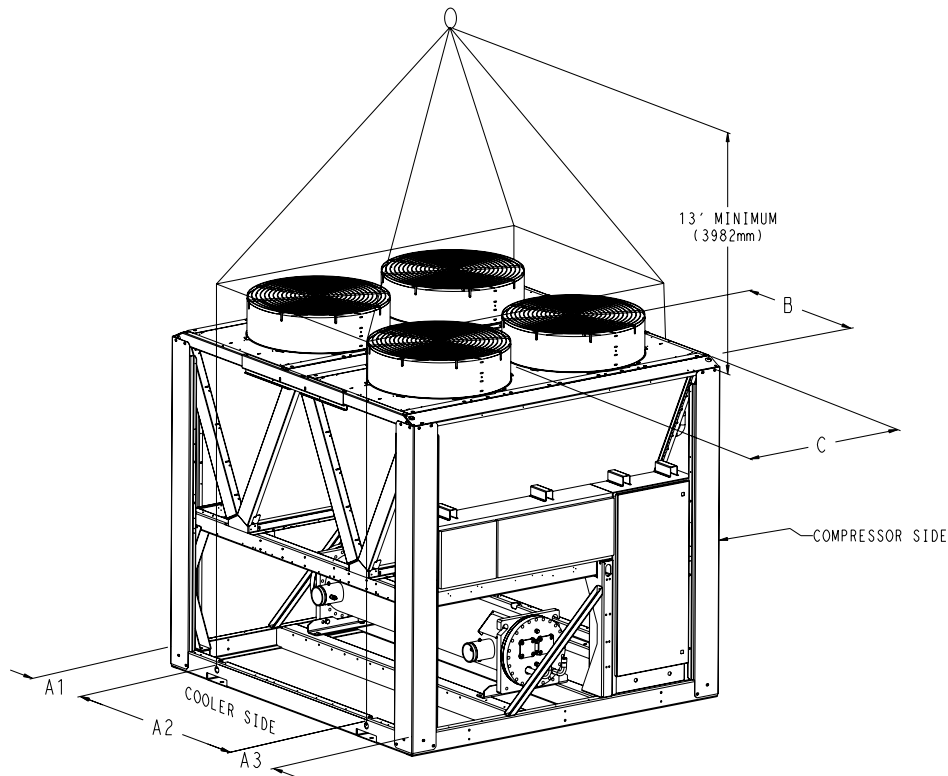




**Fig. 15 — 30RB Base Rail Cross Section**



**Fig. 16 — 30RB Mounting Plate**



**CAUTION- NOTICE TO RIGGERS:**

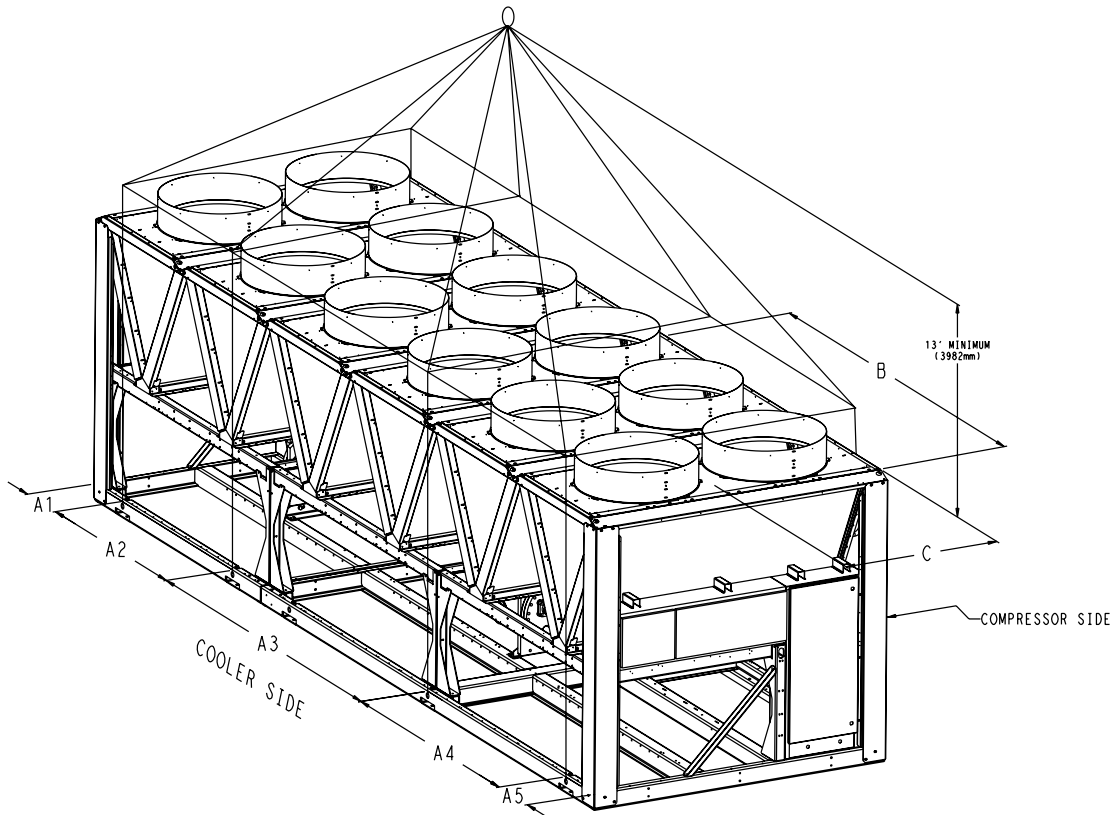
ALL PANELS MUST BE IN PLACE WHEN RIGGING. DO NOT ATTEMPT TO FORK THESE UNITS IF NO SKID IS SUPPLIED.

**NOTES:**

1. 1.50 DIA. (38.1mm) LIFTING HOLES PROVIDED FOR FIELD SUPPLIED CLEVIS.
2. RIG WITH A MINIMUM OF 25FT (7620MM) LENGTH CHAINS OR CABLES.
3. IF CENTRAL LIFTING POINT IS USED, IT MUST BE A MINIMUM OF 13 FT. (3962mm) ABOVE THE TOP OF THE UNIT.
4. SPREADER BARS MADE FROM STEEL OR DOUBLE NAILED, AND NOTCHED 2X6's APPROXIMATELY 8FT. (2438mm) LONG, MUST BE PLACED JUST ABOVE THE TOP OF THE UNIT (AND STACKS) TO REDUCE THE RISK OF DAMAGE TO THE TOP OF THE UNIT AND COILS.
5. IF OVERHEAD RIGGING IS NOT AVAILABLE, THE UNIT CAN BE MOVED ON ROLLERS OR DRAGGED. WHEN UNIT IS MOVED ON ROLLERS, THE UNIT SKID, IF EQUIPPED, MUST BE REMOVED. TO LIFT THE UNIT, USE JACKS AT THE RIGGING POINTS. USE A MINIMUM OF ONE ROLLER EVERY 6FT. (1829mm) TO DISTRIBUTE THE LOAD. IF THE UNIT IS TO BE DRAGGED, LIFT THE UNIT AS DESCRIBED ABOVE, AND PLACE UNIT ON A PAD. APPLY MOVING FORCE TO THE PAD, NOT THE UNIT. WHEN IN ITS FINAL LOCATION, RAISE THE UNIT AND REMOVE THE PAD.
6. CHECK BILL OF LADING FOR SHIPPING WEIGHT OF UNIT.

MODEL NUMBER	MAX. SHIPPING WT. W/O PACKAGING		MAX. SHIPPING WT. WITH PACKAGING		LIFTING HOLES						CENTER OF GRAVITY			
					"A1"		"A2"		"A3"		"B"		"C"	
	LB	KG	LB	KG	IN.	MM	IN.	MM	IN.	MM	IN.	MM	IN.	MM
30RBA060	4705	2134	5685	2579	18.0	456.6	58.3	1479.8	18.0	456.6	45.8	1164.3	40.9	1037.9
30RBA060-CU	5187	2353	6167	2797	18.0	456.6	58.3	1479.8	18.0	456.6	45.8	1164.3	40.9	1037.9
30RBA070	4911	2228	5891	2672	18.0	456.6	58.3	1479.8	18.0	456.6	45.9	1164.8	39.9	1012.7
30RBA070-CU	5393	2446	6373	2891	18.0	456.6	58.3	1479.8	18.0	456.6	45.9	1164.8	39.9	1012.7
30RBA080	5258	2385	6238	2830	18.0	456.6	58.3	1479.8	18.0	456.6	47.5	1205.7	39.8	1012.2
30RBA080-CU	5740	2604	6720	3048	18.0	456.6	58.3	1479.8	18.0	456.6	47.5	1205.7	39.8	1012.2
30RBA090	6590	2989	7660	3475	16.1	408.9	109.0	2769.3	16.1	408.9	64.0	1624.8	40.1	1017.4
30RBA090-CU	7314	3318	8384	3803	16.1	408.9	109.0	2769.3	16.1	408.9	64.0	1624.8	40.1	1017.4
30RBA100	6813	3090	7883	3576	16.1	408.9	109.0	2769.3	16.1	408.9	63.5	1614.0	39.3	998.5
30RBA100-CU	7537	3419	8607	3904	16.1	408.9	109.0	2769.3	16.1	408.9	63.5	1614.0	39.3	998.5
30RBA110	7067	3206	8137	3691	16.1	408.9	109.0	2769.3	16.1	408.9	67.4	1713.0	39.3	997.1
30RBA110-CU	7791	3534	8861	4019	16.1	408.9	109.0	2769.3	16.1	408.9	67.4	1713.0	39.3	997.1
30RBA120	8238	3737	9398	4263	16.1	408.9	156.0	3963.3	16.1	408.9	92.3	2345.5	39.1	992.7
30RBA120-CU	9082	4120	10242	4646	16.1	408.9	156.0	3963.3	16.1	408.9	92.3	2345.5	39.1	992.7
30RBA130	8593	3898	9753	4424	16.1	408.9	156.0	3963.3	16.1	408.9	89.5	2272.4	38.7	983.2
30RBA130-CU	9558	4336	10718	4862	16.1	408.9	156.0	3963.3	16.1	408.9	89.5	2272.4	38.7	983.2
30RBA150	9808	4449	10968	4975	16.1	408.9	156.0	3963.3	16.1	408.9	94.2	2392.2	38.7	982.8
30RBA150-CU	10773	4887	11933	5413	16.1	408.9	156.0	3963.3	16.1	408.9	94.2	2392.2	38.7	982.8
DEDUCT THESE VALUES FOR UNITS WITH NO PUMP OPTIONS														
	SINGLE PUMP DEDUCT (LB)		NO PUMP DEDUCT (LB)					SINGLE PUMP DEDUCT (LB)		NO PUMP DEDUCT (LB)				
30RBA060,070	318		833					383		923				
30RBA080-100	423		923					592		1245				
CU = COPPER FINNED COILS										00PSN500037300A				

**Fig. 17 — Unit Rigging Label Detail 30RB060-150**



**CAUTION- NOTICE TO RIGGERS:**

ALL PANELS MUST BE IN PLACE WHEN RIGGING. DO NOT ATTEMPT TO FORK THESE UNITS IF NO SKID IS SUPPLIED.

**NOTES:**

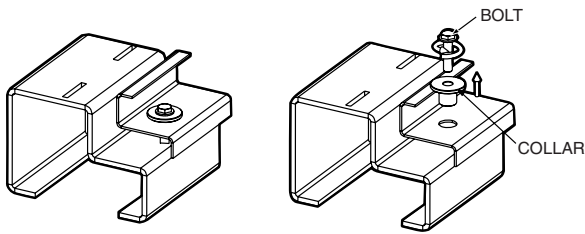
1. 1.50 DIA. (38.1mm) LIFTING HOLES PROVIDED FOR FIELD SUPPLIED CLEVIS.
2. RIG WITH A MINIMUM OF 25FT (7620MM) LENGTH CHAINS OR CABLES.
3. IF CENTRAL LIFTING POINT IS USED, IT MUST BE A MINIMUM OF 13 FT. (3962mm) ABOVE THE TOP OF THE UNIT.
4. SPREADER BARS MADE FROM STEEL OR DOUBLE NAILED, AND NOTCHED 2X6's APPROXIMATELY 8FT. (2438mm) LONG, MUST BE PLACED JUST ABOVE THE TOP OF THE UNIT (AND STACKS) TO REDUCE THE RISK OF DAMAGE TO THE TOP OF THE UNIT AND COILS.
5. IF OVERHEAD RIGGING IS NOT AVAILABLE, THE UNIT CAN BE MOVED ON ROLLERS OR DRAGGED. WHEN UNIT IS MOVED ON ROLLERS, THE UNIT SKID, IF EQUIPPED, MUST BE REMOVED. TO LIFT THE UNIT, USE JACKS AT THE RIGGING POINTS. USE A MINIMUM OF ONE ROLLER EVERY 6FT. (1829mm) TO DISTRIBUTE THE LOAD. IF THE UNIT IS TO BE DRAGGED, LIFT THE UNIT AS DESCRIBED ABOVE, AND PLACE UNIT ON A PAD. APPLY MOVING FORCE TO THE PAD, NOT THE UNIT. WHEN IN ITS FINAL LOCATION, RAISE THE UNIT AND REMOVE THE PAD.
6. CHECK BILL OF LADING FOR SHIPPING WEIGHT OF UNIT.

MODEL NUMBER	MAX. SHIPPING WT. W/O PACKAGING		MAX. SHIPPING WT. WITH PACKAGING		LIFTING HOLES										CENTER OF GRAVITY			
	LB	KG	LB	KG	"A1"		"A2"		"A3"		"A4"		"A5"		"B"		"C"	
					IN.	MM	IN.	MM	IN.	MM	IN.	MM	IN.	MM	IN.	MM	IN.	MM
30RBA160	10900	4944	12150	5511	16.1	408.9	94.0	2388.0	109.0	2769.3	16.1	408.9	N/A	N/A	120.7	3064.9	39.1	994.4
30RBA160-CU	12106	5491	13356	6058	16.1	408.9	94.0	2388.0	109.0	2769.3	16.1	408.9	N/A	N/A	120.7	3064.9	39.1	994.4
30RBA170	11235	5096	12485	5663	16.1	408.9	94.0	2388.0	109.0	2769.3	16.1	408.9	N/A	N/A	122.6	3113.6	38.5	978.1
30RBA170-CU	12441	5643	13691	6210	16.1	408.9	94.0	2388.0	109.0	2769.3	16.1	408.9	N/A	N/A	122.6	3113.6	38.5	978.1
30RBA190	12647	5737	13987	6345	16.1	408.9	109.0	2769.3	32.0	812.7	109.3	2769.3	16.1	408.9	140.9	3578.3	38.4	974.3
30RBA190-CU	14094	6393	15434	7001	16.1	408.9	109.0	2769.3	32.0	812.7	109.3	2769.3	16.1	408.9	140.9	3578.3	38.4	974.3
30RBA210	13018	5905	14358	6513	16.1	408.9	62.0	1575.3	110.0	2794.4	78.0	1981.7	16.1	408.9	138.9	3527.6	36.1	917.5
30RBA210-CU	14465	6561	15805	7169	16.1	408.9	62.0	1575.3	110.0	2794.4	78.0	1981.7	16.1	408.9	138.9	3527.6	36.1	917.5
30RBA225	13351	6056	14691	6664	16.1	408.9	62.0	1575.3	110.0	2794.4	78.0	1981.7	16.1	408.9	141.3	3588.4	35.7	906.4
30RBA225-CU	14798	6712	16138	7320	16.1	408.9	62.0	1575.3	110.0	2794.4	78.0	1981.7	16.1	408.9	141.3	3588.4	35.7	906.4
30RBA250	14752	6691	16182	7340	16.1	408.9	109.0	2769.3	110.0	2794.4	78.0	1981.7	16.1	408.9	158.3	4021.7	35.8	910.1
30RBA250-CU	16441	7457	17871	8106	16.1	408.9	109.0	2769.3	110.0	2794.4	78.0	1981.7	16.1	408.9	158.3	4021.7	35.8	910.1
30RBA275	16199	7348	17719	8037	16.1	408.9	62.0	1575.3	141.0	3582.0	141.0	3582.0	16.1	408.9	191.2	4856.9	36.0	913.8
30RBA275-CU	18129	8223	19649	8913	16.1	408.9	62.0	1575.3	141.0	3582.0	141.0	3582.0	16.1	408.9	191.2	4856.9	36.0	913.8
30RBA300	17590	7979	19200	8709	16.1	408.9	109.0	2769.3	141.0	3582.0	141.0	3582.0	16.1	408.9	209.3	5316.8	36.0	915.6
30RBA300-CU	19761	8964	21371	9694	16.1	408.9	109.0	2769.3	141.0	3582.0	141.0	3582.0	16.1	408.9	209.3	5316.8	36.0	915.6
DEDUCT THESE VALUES FOR UNITS WITH NO PUMP OPTIONS																		
	SINGLE PUMP DEDUCT (LB)		NO PUMP DEDUCT (LB)															
30RBA160-190	592		1245															
CU = COPPER FINNED COILS																00PNS500037400A		

**Fig. 18 — Unit Rigging Label Detail 30RB160-300**

## Step 2 — Remove Compressor Rack Holddown Bolts

The 30RB units are shipped with holddown bolts securing the compressor rail assembly to the unit base frame. These bolts are located between the compressors in the front and rear of the compressor rail assembly. These bolts and hold-down assemblies must be removed for the vibration isolation system to operate properly. Loosen and remove the bolt and collar assembly as shown in Fig. 19.



**Fig. 19 — Compressor Rack Holddown Bolts**

See Table 5 for the number of holddown assemblies for each unit.

Isolation mounts for the compressor rail assembly are located directly in front of and behind each compressor. Do not loosen or remove the isolation mounts, only the shipping bolts. There are 4 bolts that hold down each compressor. Do not loosen these bolts.

**Table 5 — Number of Holddown Assemblies**

UNIT 30RB	CIRCUIT A + B	CIRCUIT A	CIRCUIT B	CIRCUIT C
060-070	4	—	—	—
080-100	4	—	—	—
110-120	—	2	4	—
130-190	—	4	4	—
210-300	—	4	4	4

MODULAR UNIT 30RB	CIRCUIT A		CIRCUIT B	
	Module A	Module B	Module A	Module B
315	4	4	4	4
330	4	4	4	4
345	4	4	4	4
360	4	4	4	4
390	4	4	4	4

## Step 3 — Cooler Fluid and Drain Piping Connections

The 30RB units are supplied with a factory-installed flow switch in the leaving water (fluid) piping. Flow switch wiring is factory installed.

To facilitate servicing it is recommended additional field-supplied air vents be installed to facilitate servicing. Locate air vents at the highest possible point of the chilled water system. In addition to field-supplied air vents, facilitate servicing in addition to flow balancing by installing field-supplied shut-off valves, thermometers, clean-out tees, pressure and temperature taps in the inlet and outlet piping. Locate valves in return and supply cooler water lines as close to the chiller as possible.

In sound sensitive applications, consider the installation of piping vibration isolators.

**FREEZE PROTECTION** — Upon completion of the field piping installation, freeze protection must be considered. Freeze protection for the cooler is available from the factory with a freeze protection option for the unit. Freeze protection for the pump (hydronic) package is standard on all units with the optional hydronic package (30RB060-190 units). External

piping freeze protection also must be considered. Since power is sometimes lost for extended periods during winter storms, freeze protection provided by heater tapes will be effective only if a back-up power supply can be assured for the unit's control circuit, heater and cooler pump. If not protected with an antifreeze solution, draining the cooler and outdoor piping is recommended if the system will not be used during freezing weather conditions.

**NOTE:** See Freeze Protection section on page 41 for a more detailed overview of freeze protection.

**IMPORTANT:** Glycol anti-freeze solutions are highly recommended since heater tapes provide no protection in the event of a power failure

**UNITS WITH HYDRONIC PUMP PACKAGE** — The 30RB060-190 units can be equipped with a factory-installed hydronic pump package consisting of a suction guide/strainer, pump, combination valve, internal piping and wiring connected at the factory.

The combination valve performs the following functions:

- Drip-tight shut-off valve
- Spring closure design with a non-slam check valve
- Flow-throttling valve

When facing the cooler side of unit, the inlet (return) water connection is on the right. The outlet (supply) water connection is on the left. The inlet is connected to the suction guide/strainer of the pump via a Victaulic-type connection. The cooler supply has water-side Victaulic-type connections (follow connection directions as provided by the coupling manufacturer). Provide proper support for the piping. If compressor and cooler grilles have been added, holes must be cut in the grilles for field piping and insulation.

The suction guide/strainer is shipped from the factory with a run-in screen. This screen is a temporary device used during the start-up/clean-up process of the chilled water circuit to prevent construction debris from damaging the pump or internal tubes of cooler. After all debris has been removed or a maximum of 24 running hours the temporary screen must be removed. See the Controls, Start-Up, Operation, Service and Troubleshooting guide for further information.

### ⚠ CAUTION

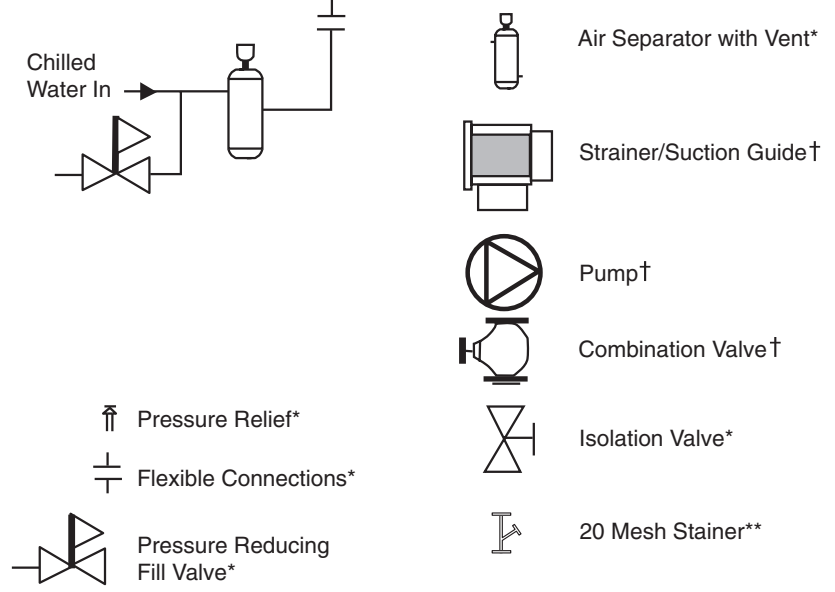
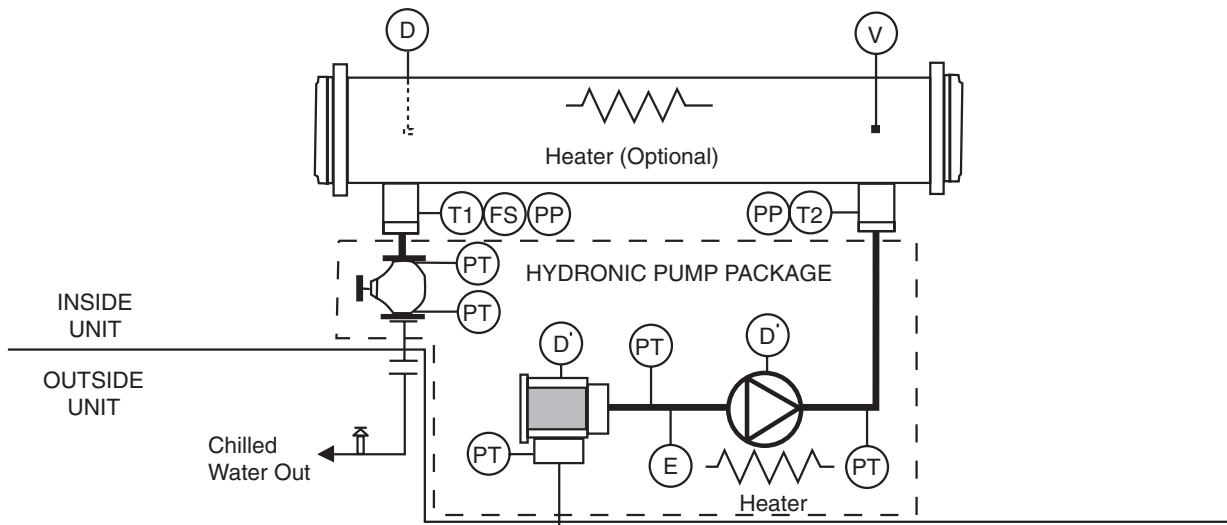
The suction guide/strainer is shipped from the factory with a run-in screen. This temporary screen must be removed after all debris has been removed or a maximum of 24 running hours. Failure to remove the temporary screen may result in damage to the pump or cooler.

**NOTE:** It is required that a field-supplied strainer with a minimum size of 20 mesh be installed within 10 feet of and ahead of the cooler inlet to prevent debris from damaging internal tubes of the cooler.

A 3/4 in. NPT fitting is installed in the inlet piping of the pump for connection to an expansion tank. Install the tank in accordance with the manufacturer's instructions.

Figures 20 and 21 illustrate typical single and dual pump packages.

Three drain connections are provided and are located at leaving water (supply) end of cooler, pump volute, and the suction guide. See Fig. 2-13 for connection location. Insulate the drain piping (in the same manner as the chilled water piping) for at least 1 ft (305 mm) from the cooler.

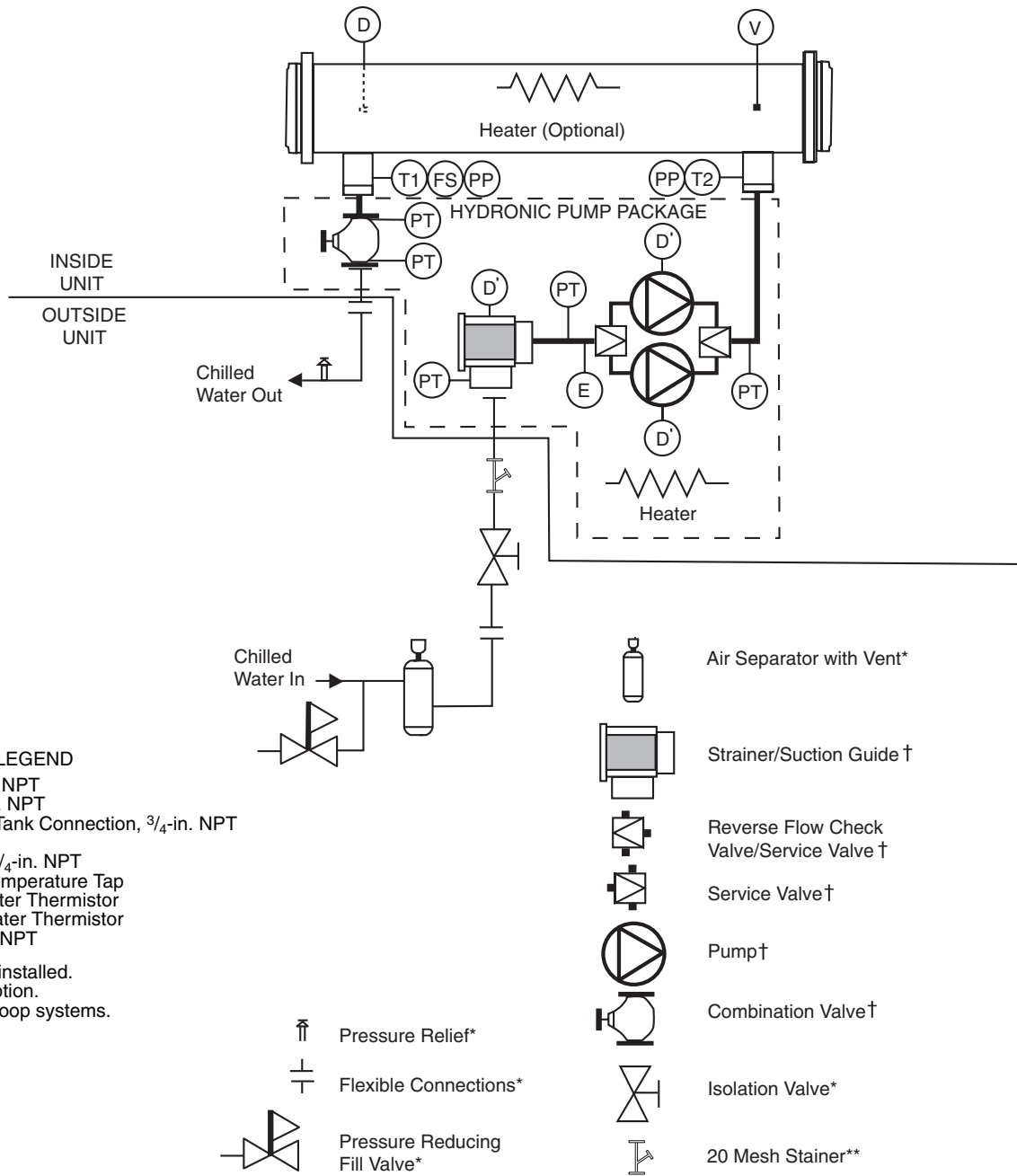


**LEGEND**

- D** — Drain, 3/4-in. NPT
- D'** — Drain, 1/4-in. NPT
- E** — Expansion Tank Connection, 3/4-in. NPT
- FS** — Flow Switch
- PP** — Pipe Plug, 1/4-in. NPT
- PT** — Pressure/Temperature Tap
- T1** — Leaving Water Thermistor
- T2** — Entering Water Thermistor
- V** — Vent, 1/4-in. NPT
- Indicates items provided with the optional hydronic pump package.

\*Field-supplied and installed.  
 †Factory-installed option.  
 \*\*Required for open loop systems.

**Fig. 20 — Typical Piping Diagram on 30RB Units with Hydronic Package — Single Pump**



**Fig. 21 — Typical Piping Diagram on 30RB Units with Hydronic Package — Dual Pumps**

**UNITS WITHOUT HYDRONIC PUMP PACKAGE** — When facing the cooler side of the unit, the inlet (return) water connection is on the right. It is required that a field-supplied strainer with a minimum size of 20 mesh be installed within 10 feet of and ahead of the cooler inlet to prevent debris from damaging internal tubes of the cooler. The outlet (supply) water connection is on the left. The cooler has water-side victaulic-type connections (follow connection directions as provided by the coupling manufacturer). Provide proper support for the piping. If compressor and cooler grilles have been added, holes must be cut in the grilles for field piping and insulation. See Fig. 22 for a typical piping diagram of a 30RB unit without a hydronic pump package.

A drain connection is located at the leaving water (supply) end of cooler. See Fig. 2-13 for connection location. Insulate the drain piping (in the same manner as the chilled water piping) for at least 12 in. (305 mm) from the unit.

**FOR ALL UNITS**

**Dual Chiller Leaving Water Sensor** — If the dual chiller algorithm is used, and the machines are installed in parallel, a dual chilled water sensor must be installed for each module. For 30RB315-390, a factory-supplied thermistor and well are shipped in the control box of each module. Install the well in the common leaving water header. See Fig. 23.

See page 41 for more dual chiller leaving water sensor information.

**Minimum Loop Volume** — The preferred minimum loop volume is dependent on the type of application. In order to obtain leaving water temperature stability for comfort cooling applications, a minimum of 3 gallons per ton (3.25 liters per kW) is required on all unit sizes. For process cooling applications, applications where high stability is critical, or operation at ambient temperatures below 32 F (0° C) is expected, the loop volume should be increased to 6 to 10 gallons per ton (6.46 to 10.76 liters per kW) of cooling.

In order to achieve this volume, it may be necessary to add a water storage tank to the water loop. If a storage tank is added to the system, it should be properly vented so that the tank can be completely filled and all air eliminated. Failure to do so could cause lack of pump stability and poor system operation. Any storage tank that is placed in the water loop should have internal baffles to allow thorough mixing of the fluid. See Fig. 24.

**System Piping** — Proper system design and installation procedures should be followed closely. The system must be constructed with pressure tight components and thoroughly tested for installation leaks. Factory-supplied hydronic packages are available with single or dual (for back-up) pumps. The factory-installed package includes all of the components above the line in Fig. 20 and 21.

Installation of water systems should follow sound engineering practice as well as applicable local and industry standards. Improperly designed or installed systems may cause unsatisfactory operation and/or system failure. Consult a water treatment specialist or appropriate literature for information regarding filtration, water treatment, and control devices. Figure 20 shows a typical installation with components that might be installed with the hydronic package of the 30RB unit.

NOTE: It is recommended for units with the hydronic package that an inlet isolation (shut-off) valve be placed exterior to the unit to allow removal and service of the entire pump assembly, if necessary. The hydronic package is supplied from the factory with a combination valve for isolation of leaving water. Also, if the unit is isolated with valves, a properly sized pressure relief valve is recommended and should be installed in the piping between the unit and the valves, following all applicable local codes.

**Air Separation** — For proper system operation, it is essential that water loops be installed with proper means to manage air in the system. Free air in the system can cause noise, reduce terminal output, stop flow, or even cause pump failure due to pump cavitation. For closed systems, equipment should be provided to eliminate all air from the system.

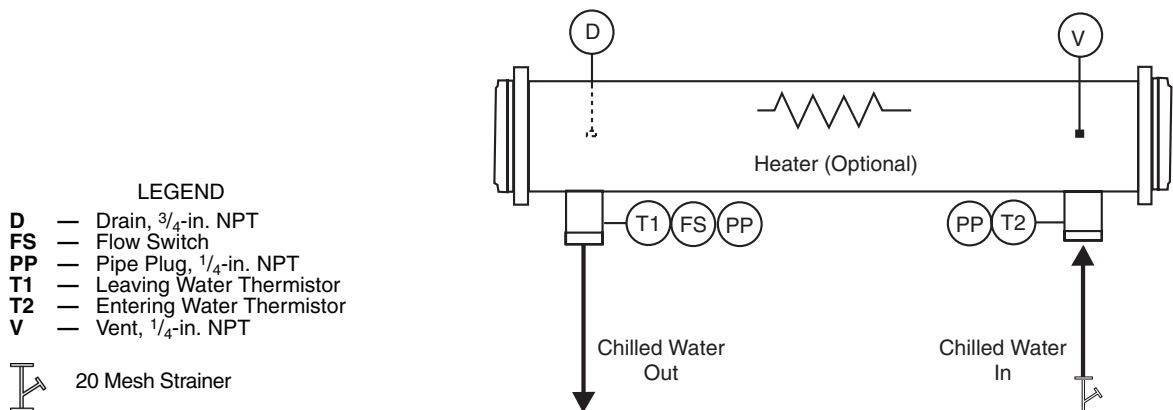
The amount of air that water can hold in solution depends on the pressure and temperature of the water/air mixture. Air is less soluble at higher temperatures and at lower pressures. Therefore, separation can best be done at the point of highest water temperature and lowest pressure. Typically, this point would be on the suction side of the pump as the water is returning from the system or terminals. This is generally the optimal place to install an air separator, if possible.

1. Install automatic air vents at all high points in the system. (If the 30RB unit is located at the high point of the system, a vent can be installed on the piping leaving the heat exchanger on the 1/4 in. NPT female port.)
2. Install an air separator in the water loop, at the place where the water is at higher temperatures and lower pressures — usually in the chilled water return piping. On a primary-secondary system, the highest temperature water is normally in the secondary loop, close to the decoupler. Preference should be given to that point on the system (see Fig. 25.) In-line or centrifugal air separators are readily available in the field.

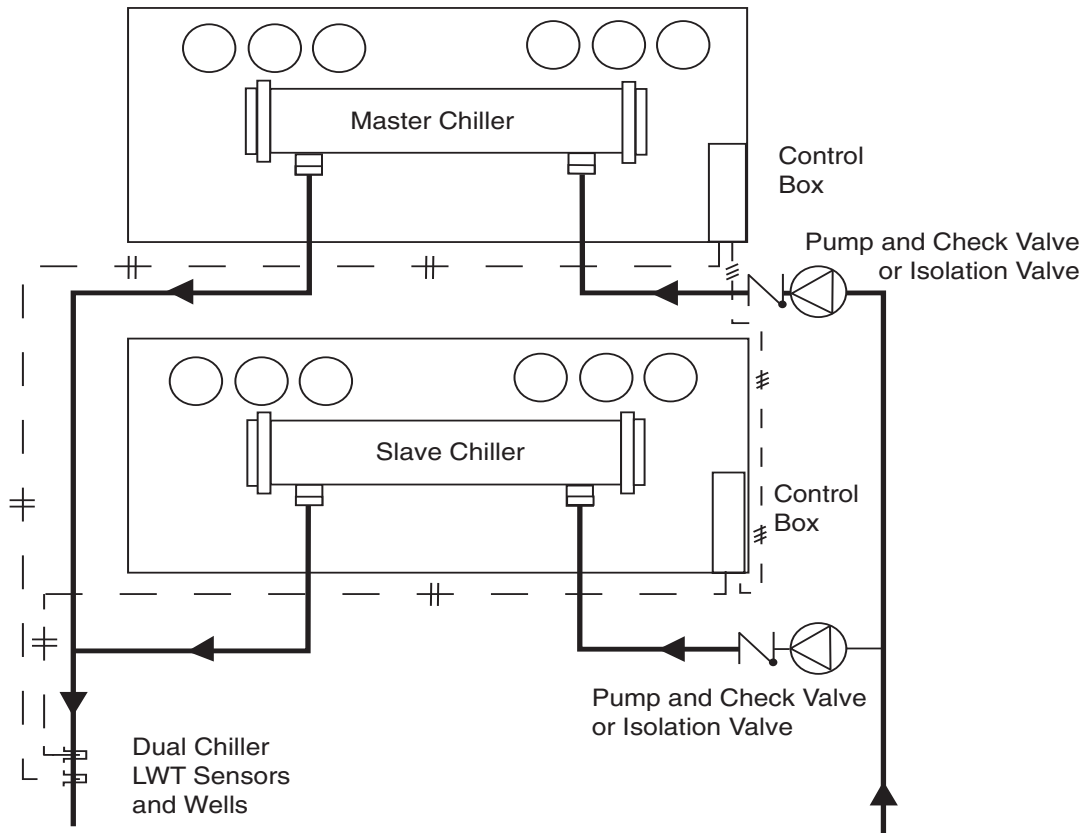
It may not be possible to install air separators at the place of the highest temperature and lowest pressure. In such cases, preference should be given to the points of highest temperature. It is important that the pipe be sized correctly so that free air can be moved to the point of separation. Generally, a water velocity of at least 2 feet per second (.6 m per second) will keep free air entrained and prevent it from forming air pockets.

Automatic vents should be installed at all physically elevated points in the system so that air can be eliminated during system operation. Provisions should also be made for manual venting during the water loop fill.

**IMPORTANT:** Automatic vents should be located in accessible locations for maintenance purposes and protected from freezing.



**Fig. 22 — Typical Piping Diagram on 30RB Units without Hydronic Package**

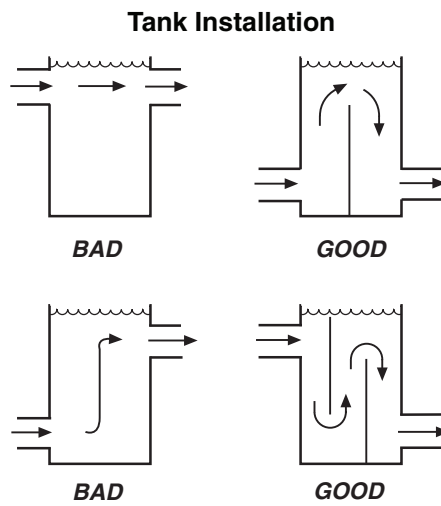


**LEGEND**

- LWT** — Leaving Water (Fluid) Temperature
- # - Field Wiring
- ## - Field Communication Wiring

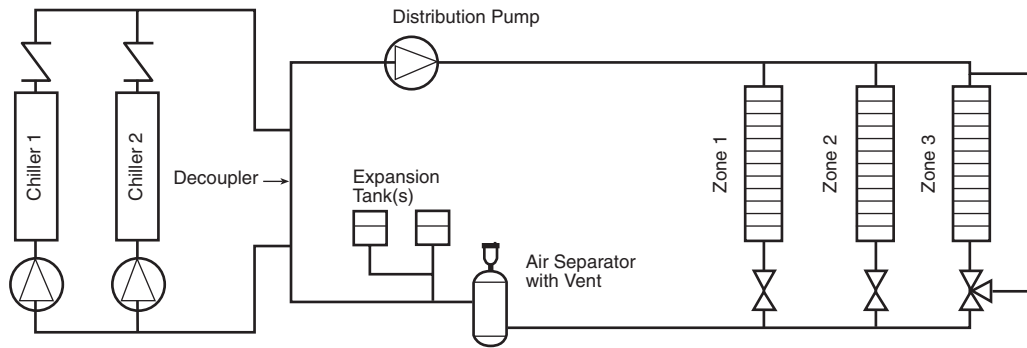
NOTE: This is a simplified piping diagram — not all hydronic specialties are shown.

**Fig. 23 — Dual Chiller Thermistor Location**



**Fig. 24 — Tank Baffling**





NOTE: Expansion tanks for 30RB hydronic kits must be installed for chillers piped in parallel in the primary water loop.

**Fig. 25 — Typical Air Separator and Expansion Tank Location on Primary-Secondary Systems**

#### Step 4 — Fill the Chilled Water Loop

**IMPORTANT:** Before starting unit, be sure all of the air has been purged from the system.

The chilled water pump (if equipped) is rated for 150 psig (1034 kPa) duty. The maximum cooler fluids side pressure is 300 psig (2068 kPa). Check the pressure rating for all of the chilled water devices installed. Do not exceed the lowest pressure rated device.

**WATER SYSTEM CLEANING** — Proper water system cleaning is of vital importance. Excessive particulates in the water system can cause excessive pump seal wear, reduce or stop flow, and cause damage of other components.

1. Install a temporary bypass around the chiller to avoid circulating dirty water and particulates into the pump package and chiller during the flush. Use a temporary circulating pump during the cleaning process. Also, be sure that there is capability to fully drain the system after cleaning. See Fig. 26.
2. Be sure to use a cleaning agent that is compatible with all system materials. Be especially careful if the system contains any galvanized or aluminum components. Both detergent-dispersant and alkaline-dispersant cleaning agents are available.
3. It is recommended to fill the system through a water meter. This provides a reference point for the future for loop volume readings, and it also establishes the correct quantity of cleaner needed in order to reach the required concentration.
4. Use a feeder/transfer pump to mix the solution and fill the system. Circulate the cleaning system for the length of time recommended by the cleaning agent manufacturer.
  - a. After cleaning, drain the cleaning fluid and flush the system with fresh water.
  - b. A slight amount of cleaning residue in the system can help keep the desired, slightly alkaline, water pH of 8 to 9. Avoid a pH greater than 10, since this will adversely affect pump seal components.
  - c. A side stream filter is recommended (see Fig. 27) during the cleaning process. Filter side flow rate should be enough to filter the entire water volume every 3 to 4 hours. Change filters as often as necessary during the cleaning process.
  - d. Remove temporary bypass when cleaning is complete.

A suction guide with an internal strainer is standard on all 30RB units with factory-installed hydronic packages. This strainer allows removal of particulates from the chilled water loop. Using the combination valve and the field-installed

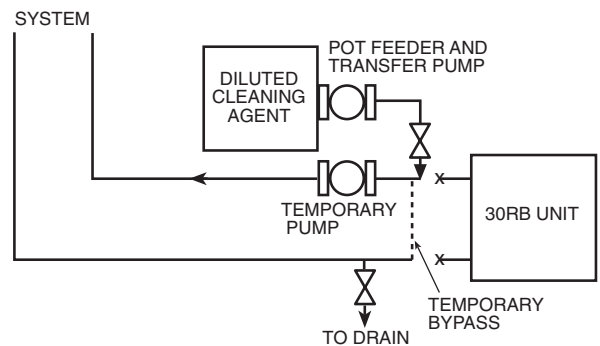
isolation valve at the inlet, the strainer can be isolated from the chilled water loop to be cleaned.

The Carrier *ComfortLink*<sup>™</sup> controls provided have a built-in feature to remind building owners or operators to clean the strainer at a pre-set time interval. Properly installed, cleaned and maintained systems will rarely need the strainer cleaned after the initial fill. This time interval is user-configurable.

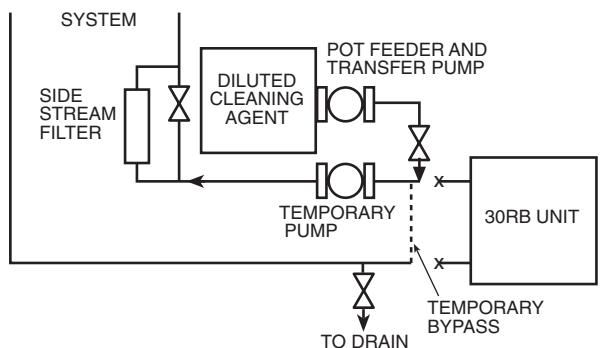
Ideally, the chilled water loop will be cleaned before the unit is connected. If the run-in screen is left in the suction guide/strainer, it is recommended that the Service Maintenance be set to alert the operator within 24 hours of start-up to be sure that the run-in screen in the suction guide/strainer is not removed at start-up.

NOTE: The suction guide/strainer must be removed after the first 24 hours of operation.

To set the time for the parameter, go to Time Clock/MCFG/W.FIL in the scrolling marquee or the handheld Navigator<sup>™</sup> display. Values for this item are input in days.



**Fig. 26 — Typical Set Up for Cleaning Process**



**Fig. 27 — Cleaning Using a Side Stream Filter**

**WATER TREATMENT** — Fill the fluid loop with water (or brine) and a corrosion-resistant inhibitor suitable for the water of the area. Consult the local water treatment specialist for characteristics of system water and a recommended inhibitor for the cooler fluid loop.

**SYSTEM PRESSURIZATION** — A proper initial cold fill pressure must be established before filling of the unit. The initial cold fill pressure is the pressure applied at the filling point to fill a system to its highest point, plus a minimum pressure at the top of the system (4 psig minimum [27.6 kPa]) to operate air vents and positively pressurize the system. The expansion tank is very important to system pressurization. The expansion tank serves several purposes:

1. Provide NPSH (Net Positive Suction Head) required for the pump to operate satisfactorily.
2. Set system pressure.
3. Accommodate expansion/contraction of water due to temperature changes.
4. Act as a pressure reference for the pump.

The expansion tank pressure must be set BEFORE the system is filled. Follow the manufacturer’s recommendation for instructions on setting the pressure in the expansion tank. The net positive suction head pressure required information is provided on the pump curves in Fig. 28-35 for units with factory-installed hydronic kits. See Table 6 for pump impeller sizes.

Once the system is pressurized, the pressure at the connection point of the expansion tank to water piping will not change unless the water loop volume changes (either due to addition/subtraction of water or temperature expansion/contraction). The pressure at this point remains the same regardless of whether or not the pump is running.

Since the expansion tank acts as a reference point for the pump, there cannot be two reference points (two expansion tanks) in a system, unless manifolded together. Where two or more 30RB chillers with the hydronic option are installed in parallel, there should not be more than one expansion tank in the system, unless manifolded together as seen in Fig. 25. It is permissible to install the expansion tank(s) in a portion of the return water line that is common to all pumps, providing that the tank is properly sized for combined system volume.

If the application involves two or more chillers in a primary secondary system, a common place for mounting the expansion tank is in the chilled water return line, just before the decoupler. See Fig. 25 for placement of expansion tank in primary-secondary systems.

If a diaphragm expansion tank is utilized (a flexible diaphragm physically separates the water/air interface) it is not recommended to have any air in the water loop. See the section on air separation on page 31 for instructions on providing air separation equipment.

**FILLING THE SYSTEM** — The initial fill of the chilled water system must accomplish three goals:

1. The entire piping system must be filled with water.
2. The pressure at the top of the system must be high enough to vent air from the system (usually 4 psig [27.6 kPa] is adequate for most vents).
3. The pressure at all points in the system must be high enough to prevent flashing in the piping or cavitation in the pump.

The pressure created by an operating pump affects system pressure at all points except one — the connection of the expansion tank to the system. This is the only location in the system where pump operation will not give erroneous pressure indications during the fill. Therefore, the best location to install the fill connection is close to the expansion tank. An air vent should be installed close by to help eliminate air that enters during the fill procedure.

When filling the system, ensure the following:

1. Remove temporary bypass piping and cleaning/flushing equipment.
2. Check to make sure all drain plugs are installed.

Normally, a closed system needs to be filled only once. The actual filling process is a fairly simple procedure. All air should be purged or vented from the system. Thorough venting at high points and circulation at room temperature for several hours is highly recommended.

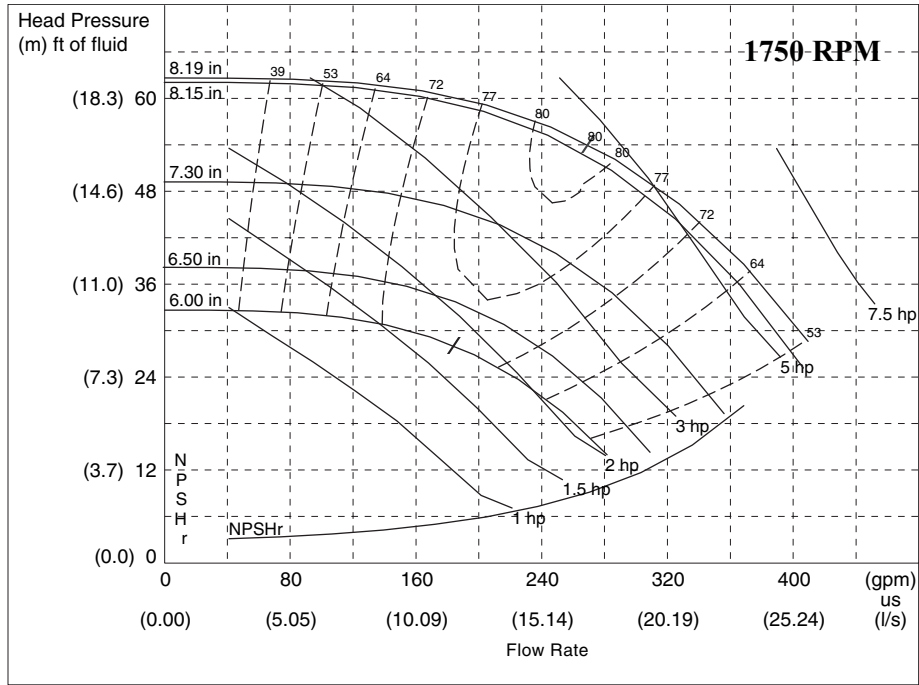
NOTE: Local codes concerning backflow devices and other protection of the city water system should be consulted and followed to prevent contamination of the public water supply. This is critical when antifreeze is used in the system.

**Table 6 — Pump Impeller Sizes**

UNIT 30RB	PUMP Hp	SINGLE PUMP				DUAL PUMP			
		Option Code*	Rpm	Impeller Dia. (in.)	Pump Curve	Option Code*	Rpm	Impeller Dia. (in.)	Pump Curve
060 070	3	0	1750	6.5	I	6	1750	6.5	V
	5	1	1750	7.3	I	7	1750	7.3	V
	7.5	2	1750	8.15	I	8	1750	8.15	V
						9	3450	5.25	VI
	10	3	3450	5.4	II	B	3450	5.9	VI
080 090 100	5	1	1750	7.3	I	7	1750	7.3	V
	7.5	2	1750	8.15	I	8	1750	8.15	V
	10	3	3450	5.4	II	B	3450	5.4	VII
	15	4	3450	6.1	II	C	3450	6.1	VII
110 120 130	5	1	1750	7.3	I	7	1750	7.3	V
	7.5	2	1750	8.15	I	8	1750	8.15	V
	10	3	3450	5.4	II	B	3450	5.4	VII
	15	4	3450	6.1	II	C	3450	6.1	VII
150 160 170 190	5	1	1750	6.5	III	—	—	—	—
	7.5	2	3450	4.6	IV	8	3450	4.6	VIII
	10	3	3450	5.0	IV	B	3450	5.0	VIII
	15	4	3450	5.5	IV	C	3450	5.5	VIII

\*Option Code refers to the Hydronics Option (position 11) in the model number. See Fig. 1 for option identification.

NOTE: Pump Selections are chiller size dependent. For example, dual pump “C” on a 30RB170 chiller is not the same as dual pump “C” on a 30RB130 chiller.

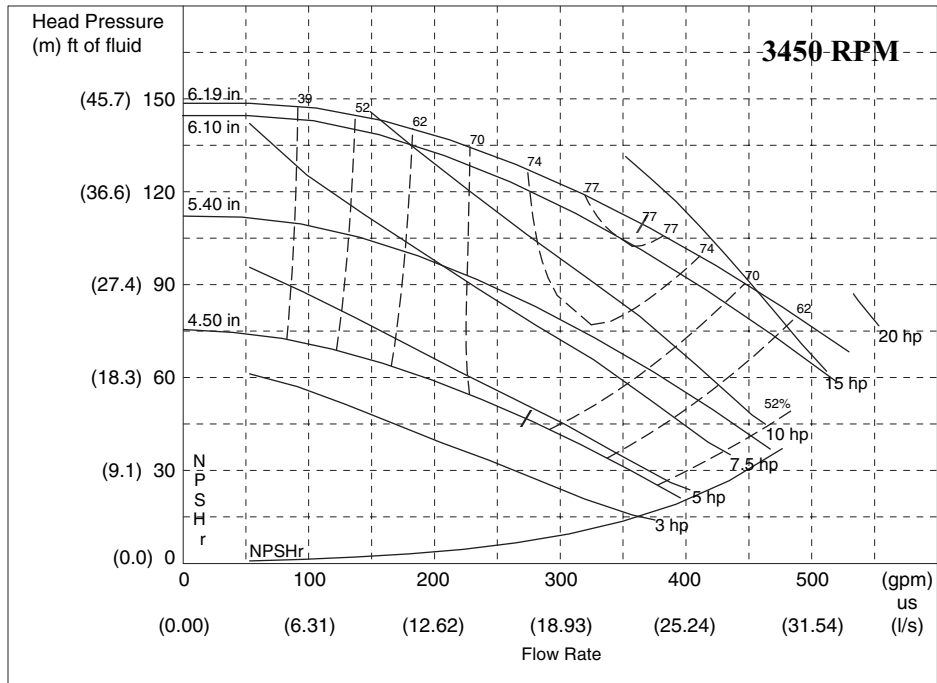


**LEGEND**

**NPSHr** — Net Positive Suction Head (Pressure) Required

NOTE: Refer to Fig. 1 option identification. Refer to Table 6 on page 34 for more information.

**Fig. 28 — Pump Curve I for Hydronic Package Single Pump (Fresh Water)**

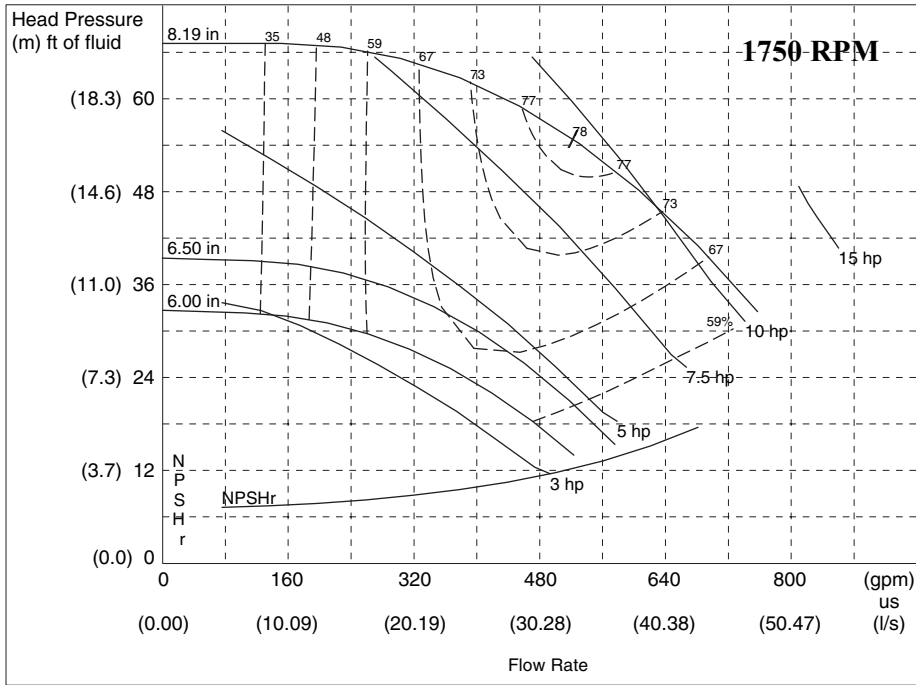


**LEGEND**

**NPSHr** — Positive Suction Head (Pressure) Required

NOTE: Refer to Fig. 1 option identification. Refer to Table 6 on page 34 for more information.

**Fig. 29 — Pump Curve II for Hydronic Package Single Pump (Fresh Water)**

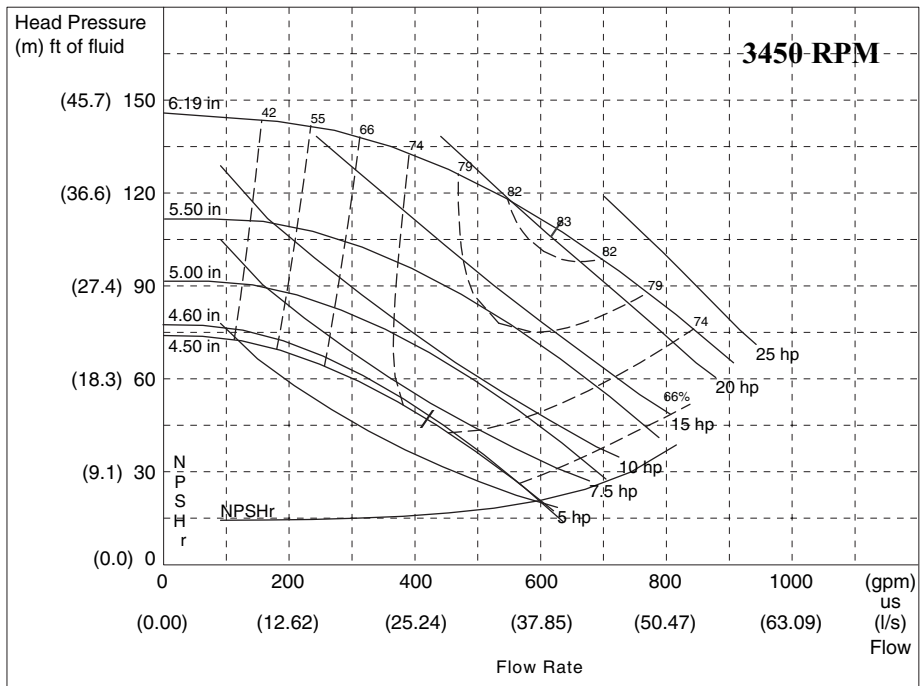


**LEGEND**

**NPSHr** — Positive Suction Head (Pressure) Required

NOTE: Refer to Fig. 1 option identification. Refer to Table 6 on page 34 for more information.

**Fig. 30 — Pump Curve III for Hydronic Package Single Pump (Fresh Water)**

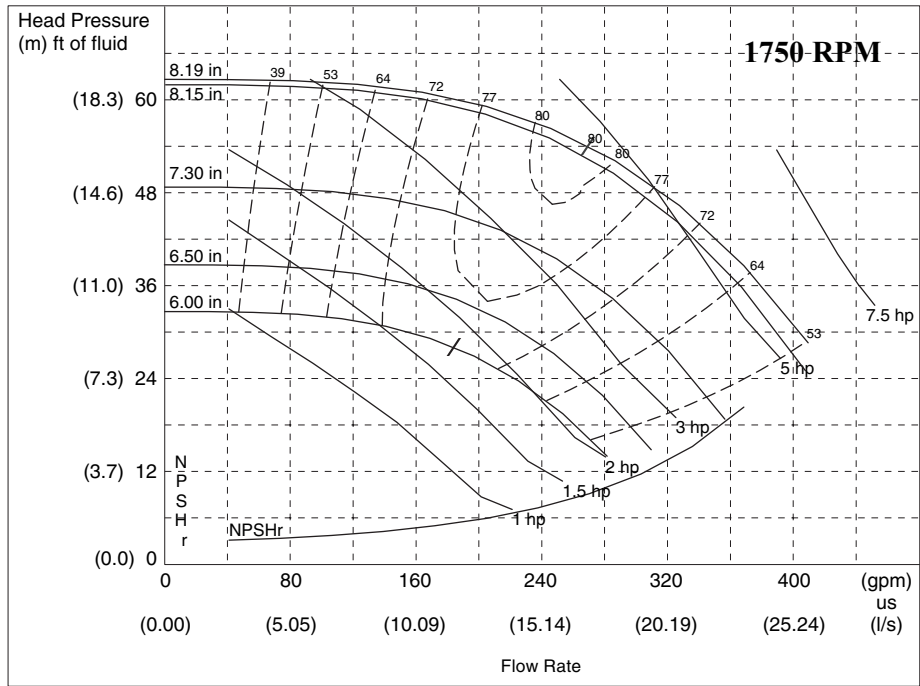


**LEGEND**

**NPSHr** — Positive Suction Head (Pressure) Required

NOTE: Refer to Fig. 1 option identification. Refer to Table 6 on page 34 for more information.

**Fig. 31 — Pump Curve IV for Hydronic Package Single Pump (Fresh Water)**

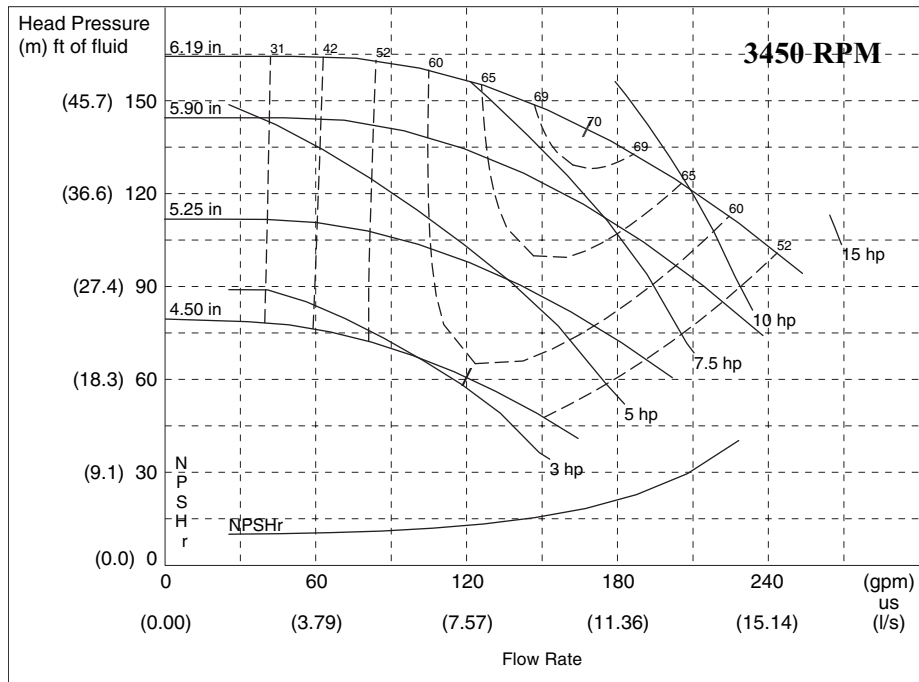


**LEGEND**

**NPSHr** — Positive Suction Head (Pressure) Required

NOTE: Refer to Fig. 1 option identification. Refer to Table 6 on page 34 for more information.

**Fig. 32 — Pump Curve V for Hydronic Package Dual Pump (Fresh Water)**

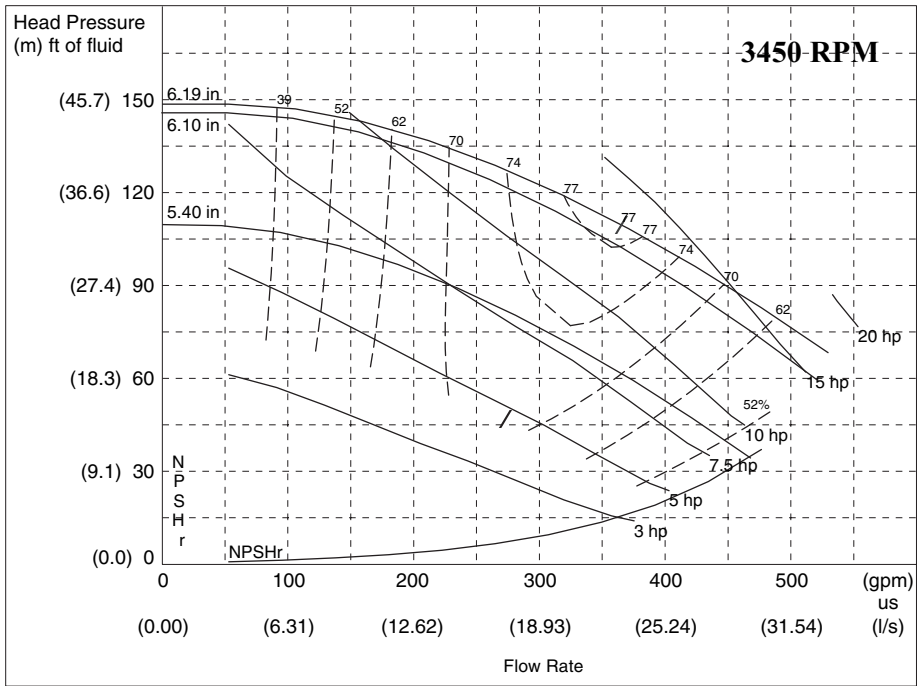


**LEGEND**

**NPSHr** — Positive Suction Head (Pressure) Required

NOTE: Refer to Fig. 1 option identification. Refer to Table 6 on page 34 for more information.

**Fig. 33 — Pump Curve VI for Hydronic Package Dual Pump (Fresh Water)**

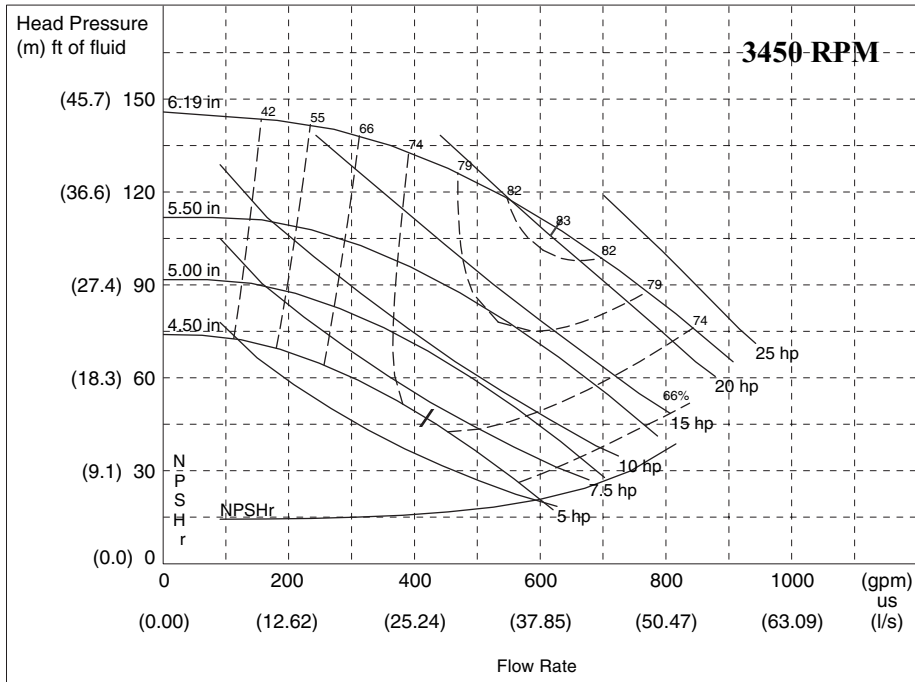


**LEGEND**

**NPSHr** — Positive Suction Head (Pressure) Required

NOTE: Refer to Fig. 1 option identification. Refer to Table 6 on page 34 for more information.

**Fig. 34 — Pump Curve VII for Hydronic Package Dual Pump (Fresh Water)**



**LEGEND**

**NPSHr** — Positive Suction Head (Pressure) Required

NOTE: Refer to Fig. 1 option identification. Refer to Table 6 on page 34 for more information.

**Fig. 35 — Pump Curve VIII for Hydronic Package Dual Pump (Fresh Water)**

**SET WATER FLOW RATE** — Once the system is cleaned, pressurized, and filled, the flow rate through the chiller needs to be established. On units with the hydronic package, this can be accomplished by using the balancing valve. Follow the manufacturer’s recommendations for setting the balancing valve. Local codes may prohibit restricting the amount of water using the balancing valve for a given motor horsepower. In this case, use the method listed in the Pump Modification/Trimming section. See Table 7 for the type of combination valve in 30RB units with the optional hydronic package.

**Table 7 — Combination Valve Details**

30RB UNIT	SINGLE/DUAL PUMP
060-130	FTV-4 in.
150-190	FTV-6 in.

NOTE: Carrier recommends a differential pressure gage when measuring pressures across the pumps or balancing valves. This provides for greater accuracy and reduces error build-up that often occurs when subtracting pressures made by different gages.

A rough estimate of water flow can also be obtained from the pressure gages across the 30RB heat exchanger.

Figures 36-38 show the relationship between gpm and heat exchanger pressure drop. It should be noted that these curves are for fresh water and “clean” heat exchangers; they do not apply to heat exchangers with fouling. To read the chart, subtract the readings of the two pressure gages on the hydronic kit. This number is the pressure drop across the heat exchanger. Adjust the factory-installed balancing valve or external balancing valve (in units without hydronic package) until the correct pressure drop is obtained for the required gpm.

**PUMP MODIFICATION/TRIMMING** — Since the pumps are constant speed, the only way to obtain greater flow with a given pump/impeller is to decrease system head. This will allow the pump to “ride” its curve to the right, resulting in increased flow. If greater flow is necessary, consider opening the combination valve. Also, verify that the strainer is clean, and that no unnecessary system resistance is present, such as partially closed isolation valves.

Once the combination valve is set, note the stem position. If later service work requires the valve to be closed, it will be easier to re-balance the system, if the original balance point is known.

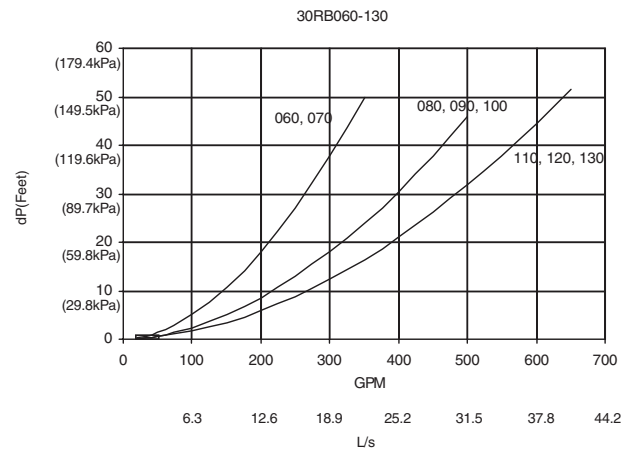
Increasing system resistance by closing the balancing valve will force the pump to “ride” its curve to the left, resulting in less flow. Although this does reduce power consumption slightly, it may not be the desirable method of reducing the flow, especially if a large reduction is needed.

The other method for reducing flow on a constant speed pump is impeller trimming. The impellers in the pumps provided in the 30RB hydronic kit can be easily removed for this purpose. Refer to the vendor literature packet supplied with the hydronic package information on Seal Replacement in the Service Section, and follow instructions for impeller removal and trimming. See Fig. 39-46 for pump envelope curve information. Trimming should only be done by a qualified machine shop that has experience in this operation. Contact your local Carrier representative for a recommended machine shop.

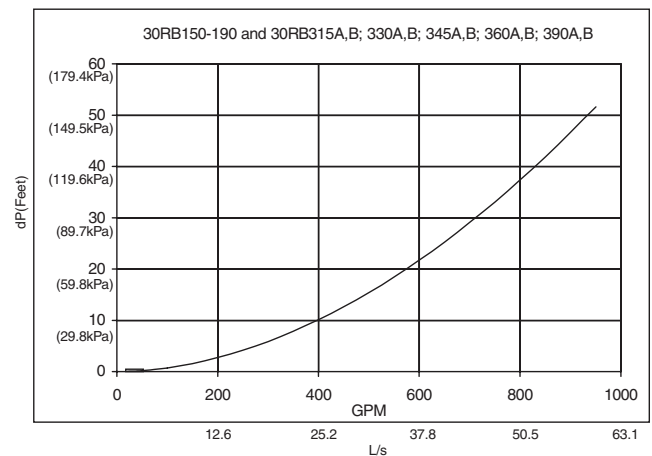
**⚠ CAUTION**

After trimming, the impeller **MUST** be balanced. Failure to balance trimmed impellers can result in excessive vibration, noise, and premature bearing failure.

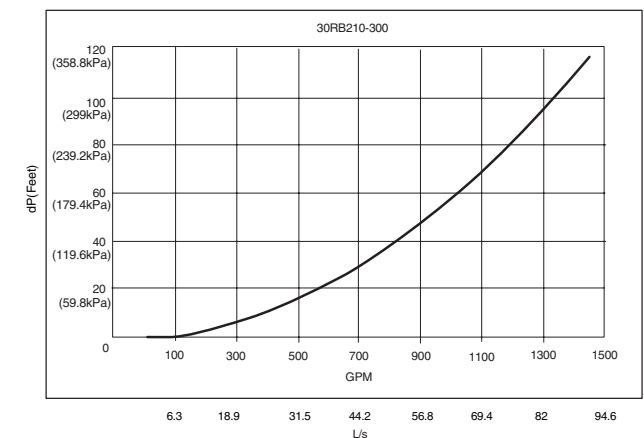
Impeller trimming has the added benefit of maximum bhp (brake horsepower) savings, which can recover the cost incurred by performing the impeller trimming.



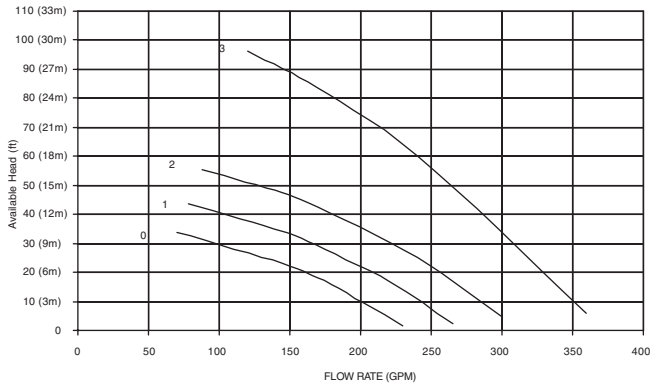
**Fig. 36 — 30RB060-130 Cooler Pressure Drop Curves**



**Fig. 37 — 30RB150-190 and 30RB315A,B; 345A,B; 360A,B; 390A,B Cooler Pressure Drop Curve**

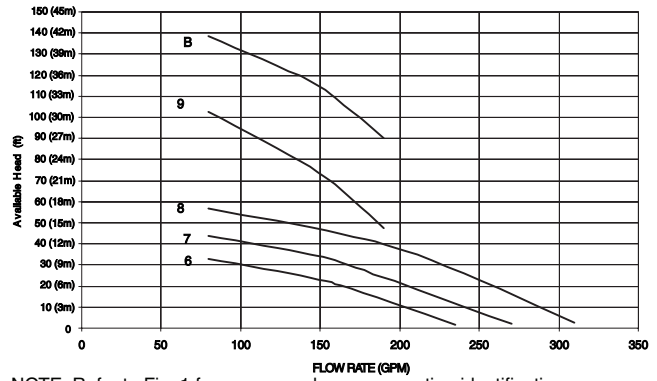


**Fig. 38 — 30RB210-300 Cooler Pressure Drop Curve**



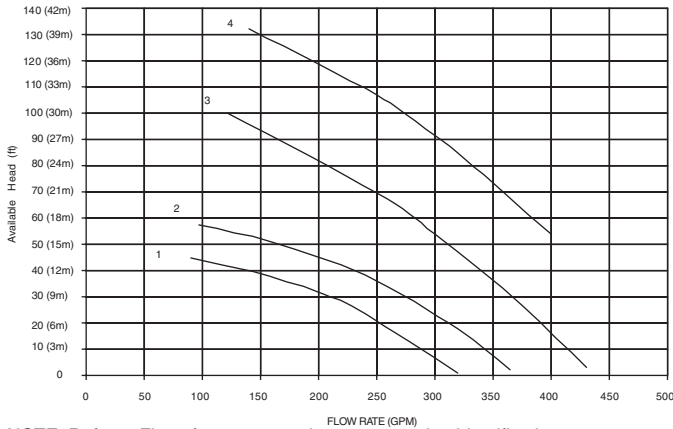
NOTE: Refer to Fig. 1 for pump envelope curve option identification.

**Fig. 39 — 30RB060, 070 —  
Single Pump Envelope Curves**



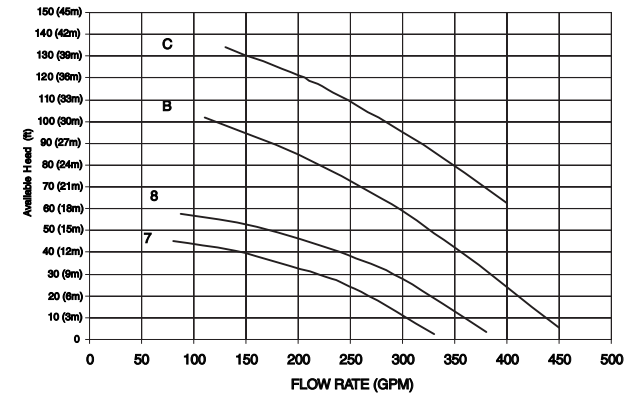
NOTE: Refer to Fig. 1 for pump envelope curve option identification.

**Fig. 43 — 30RB060, 070 —  
Dual Pump Envelope Curves**



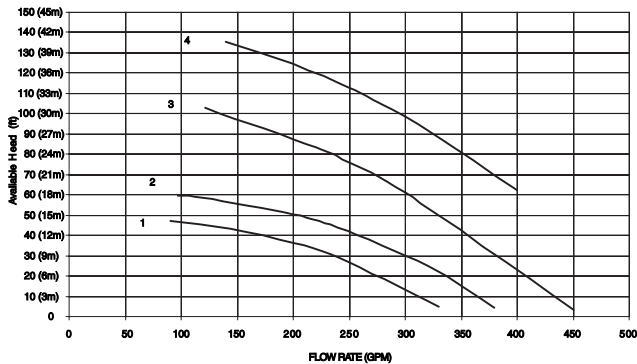
NOTE: Refer to Fig. 1 for pump envelope curve option identification.

**Fig. 40 — 30RB080, 090, 100 —  
Single Pump Envelope Curves**



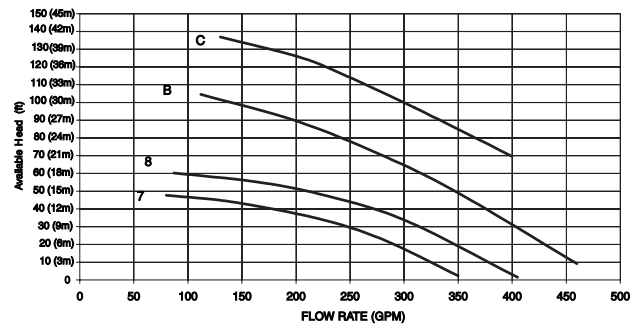
NOTE: Refer to Fig. 1 for pump envelope curve option identification.

**Fig. 44 — 30RB080, 090, 100 —  
Dual Pump Envelope Curves**



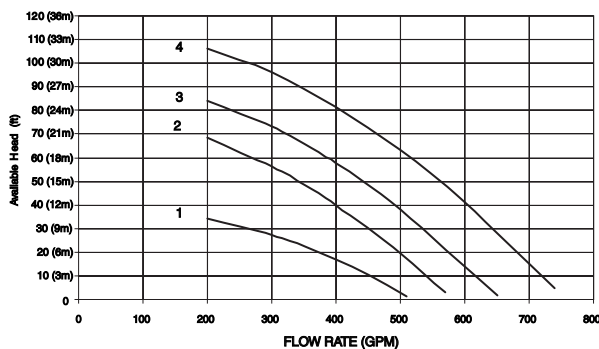
NOTE: Refer to Fig. 1 for pump envelope curve option identification.

**Fig. 41 — 30RB110, 120, 130 —  
Single Pump Envelope Curves**



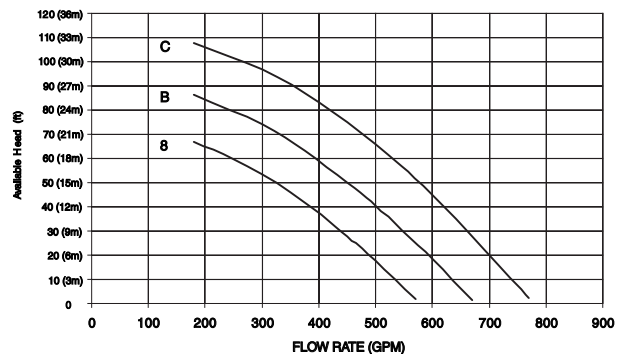
NOTE: Refer to Fig. 1 for pump envelope curve option identification.

**Fig. 45 — 30RB110, 120, 130 —  
Dual Pump Envelope Curves**



NOTE: Refer to Fig. 1 for pump envelope curve option identification.

**Fig. 42 — 30RB160, 170, 190 —  
Single Pump Envelope Curves**



NOTE: Refer to Fig. 1 for pump envelope curve option identification.

**Fig. 46 — 30RB160, 170, 190 —  
Single Pump Envelope Curves**



PREPARATION FOR YEAR ROUND OPERATION — If the unit is in operation year-round, add sufficient suitable inhibited antifreeze solution such as propylene or ethylene glycol to chilled water to prevent freezing under low-ambient temperature operating conditions. Consult local water treatment specialist on characteristics of water and recommended inhibitor.

**IMPORTANT:** Glycol anti-freeze solutions are highly recommended since heater tapes provide no protection in the event of a power failure.

If the unit is equipped with low ambient temperature head pressure control, field-fabricated and field-installed wind baffles are required if the wind velocity is anticipated to be greater than 5 mph (8 km/h). Two different baffles are required, one for the control box end and one for the opposite end of the control box. Wind baffles should be constructed with minimum 18-gage galvanized sheet metal or other suitable corrosion-resistance material with cross breaks for strength. Use field-supplied screws to attach baffles to the corner posts of the machine. Be sure to hem or turn a flange on all edges to eliminate sharp edges on the baffles.

**▲ WARNING**

To avoid possibility of electrical shock, open all disconnects before installing or servicing this accessory.

**▲ CAUTION**

To avoid damage to the refrigerant coils and electrical components, use extreme care when drilling screw holes and screwing in fasteners.

Mount the smaller height baffle on the end of the control box. It is recommended that the upper notches be used for mounting the baffles. This reduces the risk of damaging the coil while drilling a mounting hole. Loosen the upper corner post bolts and slide the baffle under the bolt and washer. Tighten the bolts. Drill holes in the bottom of the flange of the baffle and mount with two screws to secure the bottom of the baffle to the corner post. Repeat the process for the opposite side. See Fig. 47.

FREEZE PROTECTION — The 30RB units are provided with a flow switch to protect against freezing situations that occur from no water flow. For freeze protection of the chiller in case of power failure during subfreezing ambient temperatures, or in other cases where water temperature falls below the freezing mark, other methods must be used. Appropriate concentrations of inhibited propylene or ethylene glycol or other suitable inhibited antifreeze solution should be considered for chiller protection where ambient temperatures are expected to fall below 32 F (0° C). Consult local water treatment specialist on characteristics of the system water and add a recommended inhibitor to the chilled water. The Carrier warranty does not cover damage due to freezing.

1. If the pump will be subjected to freezing temperatures, steps must be taken to prevent freeze damage. If the pump will not be used during this time, it is recommended to drain the pump and hydronic package and these components are back-flushed with inhibited glycol. Otherwise, a

glycol-water solution should be considered as the heat transfer fluid. Drains are located on the pump(s) and suction guide/strainer for units with hydronic kits. Units without hydronic kits have a drain mounted on the bottom of the heat exchanger near the leaving water connection of the heat exchanger.

NOTE: Do not use automobile antifreeze, or any other fluid that is not approved for heat exchanger duty. Only use appropriately inhibited glycols, concentrated to provide adequate protection for the temperature considered.

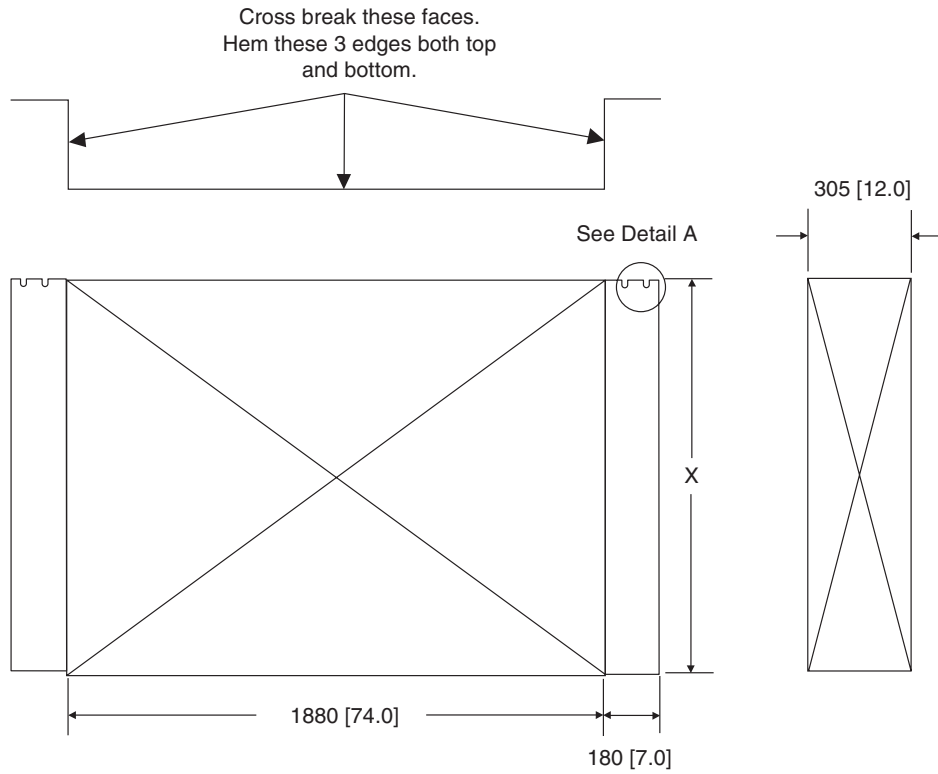
2. Use an electric tape heater for the external piping, if unit will be exposed to freezing temperatures.
3. Ensure that power is available to the chiller at all times, even during the off-season, so that the pump and cooler heaters have power. Also make sure that the piping tape heaters have power.
4. On units with pump packages, a heater is supplied with the hydronic package that will protect this section from freezing in outdoor-air temperatures down to -20 F (-29 C), except in the case of a power failure. The Carrier warranty does not cover damage due to freezing.
5. Cooler heaters that will protect components down to -20 F (-28.9 C) can be ordered as a factory-installed option. Again, it should be noted that these heaters will not protect the cooler from freezing in the event of a power failure. The Carrier warranty does not cover damage due to freezing.

PREPARATION FOR WINTER SHUTDOWN — If the unit is not operational during the winter months, at the end of cooling season:

**▲ CAUTION**

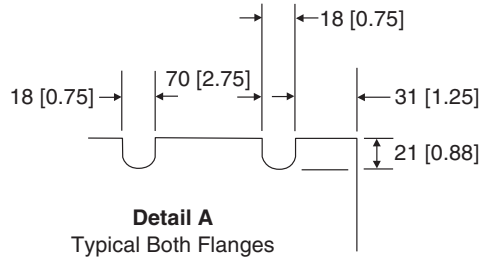
Failure to remove power before draining heater equipped coolers and hydronic packages can result in heater tape and insulation damage.

1. If the unit has an optional heater on the cooler and the cooler will not be drained, do not shut off power disconnect during off-season shutdown. If the unit has an optional heater on the cooler and the cooler will be drained, open the circuit breaker for the heater, CB-HT or shut off power during off-season shutdown.
2. Draining the fluid from the system is highly recommended. If the unit is equipped with a hydronic package, there are additional drains in the pump housing and strainer that must be opened to allow for all of the water to drain.
3. Replace the drain plug and add 2 gallons (7.6 liters) of a suitable corrosion-inhibited anti-freeze solution such as propylene glycol to the cooler to prevent freezing of any remaining water in system. Antifreeze can be added through the vent on top of cooler. If the unit has a hydronic pump package, the pump must also be treated in the same manner.
4. Open one of the thermistor connections to allow air to escape the vessel and the anti-freeze to enter.
5. At the beginning of the next cooling season, be sure that there is refrigerant pressure on each circuit before refilling cooler, add recommended inhibitor, and reset the CB-HT (circuit breaker heater) (if opened) or restore power.



POSITION	BAFFLE HEIGHT (X)
Control/Power End	635 [25.0]
Opposite Control/Power End	1040 [41.0]

NOTES:  
 1. Material: 18 ga. Corrosion Resistant Sheet Metal.  
 2. Dimensions are in mm [inches].



**Fig. 47 — Field-Fabricated and Field-Installed Wind Baffles**

## Step 5 — Make Electrical Connections

### ⚠ WARNING

Electrical shock can cause personal injury and death. Shut off all power to this equipment during installation. There may be more than one disconnect switch. Tag all disconnect locations to alert others not to restore power until work is completed.

**POWER SUPPLY** — The electrical characteristics of the available power supply must agree with the unit nameplate rating. Supply voltage must be within the limits shown. Some units have options for multiple power connections. See Tables 8-12 for electrical requirements and Fig. 48 for electrical connection information.

**IMPORTANT:** Operating unit on improper supply voltage or with excessive phase imbalance constitutes abuse and may adversely affect Carrier warranty.

**POWER WIRING** — All power wiring must comply with applicable local and national codes. Install field-supplied branch circuit fused disconnect per NEC of a type that can be locked OFF or OPEN. Disconnect must be within sight and readily accessible from the unit in compliance with NEC Article 440-14. In the power box,  $\frac{7}{8}$  in. holes are provided for power entry. The holes will need to be enlarged to accept the appropriate conduit. NEC also requires all conduits from a conditioned space to the power box(es) be sealed to prevent airflow and moisture into the control box.

Duplex units require at least two separate power supplies, at least one for each module, depending on the power supply option ordered. See Fig. 48.

General Wiring Notes:

1. The control circuit does NOT require a separate power source. A step-down transformer from the main three-phase power supply obtains control circuit power. Be sure that the appropriate connection tap is connected on all transformers for the supply voltage. Up to two terminal blocks are provided for field-wired control devices.
2. Cooler and pump heaters (if factory installed) are wired in the control circuit so they are operable as long as the main power supply to the unit is ON. A factory-installed and set overload device protects them.

**NOTE:** The field-supplied disconnect should never be off except when unit is being serviced or is to be down for a prolonged period, in which case the cooler should be drained.

3. Power entry depends on the size and power entry option ordered.
4. Maximum field wire sizes allowed by lugs on terminal block/non-fused disconnect are listed in Tables 8 and 9.
5. Terminals for field power supply are suitable for copper conductors. Insulation must be rated 75 C minimum.

**IMPORTANT:** To ensure power to the heaters, make sure power to the unit is always on (except during service or a prolonged shutdown).

### ⚠ CAUTION

Proper rotation of condenser fan(s) and pump(s) MUST be verified before pumps or compressors are started. Consult the Controls, Start-Up and Operation guide provided with 30RB060-390 units for correct procedure. Improper pump rotation can cause permanent damage to pump impeller and housing. If pump(s) have been removed for trimming, verify wiring is reconnected in the original manner.

**CONTROL POWER** — Control power is obtained from the main power supply and does NOT require a separate source. A toggle switch (marked SW2 on the unit label diagram and by the switch) allows the control circuit to be manually disconnected when necessary. Cooler and pump heaters (if installed) are in an inoperable state when this switch is in the Off position.

**IMPORTANT:** For 208-v systems, the connection tap for all transformers must be changed. The factory default setting is for 230-v. Failure to connect to the proper tap may result in unreliable operation.

**FIELD CONTROL OPTION WIRING** — Install field control wiring options. See Fig. 48. Some options, such as 4 to 20 mA Demand Limit that requires the Energy Management Module, may require that accessories be installed first if not factory installed for terminal connections.

**DUAL CHILLER LEAVING WATER SENSOR** — If the Dual Chiller algorithm is used and the machines are installed in parallel, an additional chilled water sensor must be installed for each chiller. For 30RB315-390 units, a factory-supplied thermistor and well are shipped in the control box of each. Install the well in the common leaving water header. See Fig 23. DO NOT relocate the chiller's leaving water thermistors. They must remain in place for the unit to operate properly.

The thermistor well is a  $\frac{1}{4}$  in. NPT fitting for securing the well in the piping. The piping must be drilled and tapped for the well. Select a location that will allow for removal of the thermistor without any restrictions. See Fig. 49.

Once the well is inserted, install the thermistors. Insert the thermistor into the well until the o-ring reaches the well body. Use the nut on the thermistor to secure the thermistor in place. Once the thermistor is in place, it is recommended that a thermistor wire loop be made and secured with a wire tie to the chilled water pipe. This will aid in thermistor retention in the well. See Fig. 50.

For 30RB315-390 units, as well as all units using the dual chiller algorithm, a Carrier Comfort Network® (CCN) bus must be connected between the two modules. See the Carrier Comfort Network Communication Bus Wiring section on page 54 for additional information.

**Table 8 — 30RB Electrical Data — Single Point Units**

UNIT 30RB	UNIT VOLTAGE			NO HYDRONIC PACKAGE				3 HP PUMP, 1750 RPM				5 HP PUMP, 1750 RPM			
	V-Hz (3 Ph)	Supplied		MCA	MOCP	ICF	Rec Fuse Size	MCA	MOCP	ICF	Rec Fuse Size	MCA	MOCP	ICF	Rec Fuse Size
		Min	Max	XL	XL	XL	XL	XL	XL	XL	XL	XL	XL	XL	XL
060	208/230-60	187	253	291.5	350	682.8	350	302.4	350	693.6	350	309.2	350	700.5	350
	380-60	342	418	150.9	175	362.9	175	156.9	175	368.8	175	160.6	175	372.6	175
	460-60	414	506	127.9	150	302.0	150	132.8	150	306.9	150	135.9	150	310.0	150
	575-60	518	633	102.4	125	244.7	110	106.4	125	248.6	125	108.8	125	251.1	125
070	208/230-60	187	253	334.7	400	777.0	400	345.6	400	787.8	400	352.4	400	794.7	400
	380-60	342	418	175.5	200	428.8	200	181.4	225	434.7	200	185.2	225	438.5	200
	460-60	414	506	147.9	175	355.9	175	152.8	175	360.8	175	155.9	175	363.9	175
	575-60	518	633	119.8	150	287.4	150	123.7	150	291.3	150	126.2	150	293.8	150
080	208/230-60	187	253	366.5	400	757.8	400	—	—	—	—	384.2	450	775.5	450
	380-60	342	418	189.3	225	401.3	200	—	—	—	—	199.0	225	411.0	225
	460-60	414	506	160.6	175	334.7	175	—	—	—	—	168.6	200	342.7	200
	575-60	518	633	128.6	150	270.9	150	—	—	—	—	135.0	150	277.3	150
090	208/230-60	187	253	433.6	500	875.9	500	—	—	—	—	451.3	500	893.6	500
	380-60	342	418	226.9	250	480.3	250	—	—	—	—	236.6	250	490.0	250
	460-60	414	506	191.4	225	399.4	225	—	—	—	—	199.4	225	407.4	225
	575-60	518	633	154.6	175	322.2	175	—	—	—	—	161.0	175	328.6	175
100	208/230-60	187	253	472.0	500	914.3	500	—	—	—	—	489.7	500	932.0	500
	380-60	342	418	248.7	250	502.1	250	—	—	—	—	258.4	300	511.8	300
	460-60	414	506	209.2	250	417.2	225	—	—	—	—	217.2	250	425.2	250
	575-60	518	633	170.0	200	337.6	200	—	—	—	—	176.4	200	344.0	200
110	208/230-60	187	253	508.6	600	950.9	600	—	—	—	—	526.3	600	968.6	600
	380-60	342	418	265.3	300	518.7	300	—	—	—	—	275.0	300	528.4	300
	460-60	414	506	224.1	250	432.1	250	—	—	—	—	232.1	250	440.1	250
	575-60	518	633	180.8	200	348.4	200	—	—	—	—	187.2	200	354.8	200
120	208/230-60	187	253	578.1	600	1020.4	600	—	—	—	—	595.8	600	1038.1	700
	380-60	342	418	304.6	350	538.0	350	—	—	—	—	314.3	350	567.6	350
	460-60	414	506	256.2	300	464.2	300	—	—	—	—	264.2	300	472.2	300
	575-60	518	633	208.2	225	325.8	225	—	—	—	—	214.6	225	382.2	250
130	208/230-60	187	253	626.7	700	1068.9	700	—	—	—	—	644.4	700	1086.6	700
	380-60	342	418	327.7	350	581.1	350	—	—	—	—	337.4	350	590.8	350
	460-60	414	506	276.5	300	484.5	300	—	—	—	—	284.5	300	492.5	300
	575-60	518	633	223.3	250	391.0	250	—	—	—	—	229.7	250	397.4	250
150	208/230-60	187	253	684.3	700	1126.5	700	—	—	—	—	702.0	800	1144.2	800
	380-60	342	418	360.4	400	613.8	400	—	—	—	—	370.1	400	623.5	400
	460-60	414	506	303.2	350	511.2	350	—	—	—	—	311.2	350	519.2	350
	575-60	518	633	246.4	250	414.1	250	—	—	—	—	252.8	300	420.5	300
160	208/230-60	187	253	744.8	800	1187.0	800	—	—	—	—	762.5	800	1204.7	800
	380-60	342	418	390.1	400	643.5	400	—	—	—	—	399.8	400	653.2	400
	460-60	414	506	328.9	350	536.9	350	—	—	—	—	336.9	350	544.9	350
	575-60	518	633	265.9	300	433.5	300	—	—	—	—	272.3	300	439.9	300
170	208/230-60	187	253	802.4	1000	1244.6	1000	—	—	—	—	820.1	1000	1262.3	1000
	380-60	342	418	422.8	450	676.2	450	—	—	—	—	432.5	450	685.9	450
	460-60	414	506	355.6	400	563.6	400	—	—	—	—	363.6	400	571.6	400
	575-60	518	633	289.0	300	456.6	300	—	—	—	—	295.4	300	463.0	300
190	208/230-60	187	253	920.5	1000	1362.7	1000	—	—	—	—	938.2	1000	1380.4	1000
	380-60	342	418	485.2	500	738.5	500	—	—	—	—	494.9	500	748.2	500
	460-60	414	506	408.0	450	616.0	450	—	—	—	—	416.0	450	624.0	450
	575-60	518	633	331.5	350	499.1	350	—	—	—	—	337.9	350	505.5	350
210	208/230-60	187	253	—	—	—	—	—	—	—	—	—	—	—	—
	380-60	342	418	501.8	600	755.1	600	—	—	—	—	—	—	—	—
	460-60	414	506	422.9	450	630.9	450	—	—	—	—	—	—	—	—
	575-60	518	633	342.3	350	509.9	350	—	—	—	—	—	—	—	—
225	208/230-60	187	253	—	—	—	—	—	—	—	—	—	—	—	—
	380-60	342	418	534.5	600	787.8	600	—	—	—	—	—	—	—	—
	460-60	414	506	449.6	450	657.6	450	—	—	—	—	—	—	—	—
	575-60	518	633	365.4	400	533.0	400	—	—	—	—	—	—	—	—
250	208/230-60	187	253	—	—	—	—	—	—	—	—	—	—	—	—
	380-60	342	418	596.8	600	850.2	600	—	—	—	—	—	—	—	—
	460-60	414	506	502.0	600	710.0	600	—	—	—	—	—	—	—	—
	575-60	518	633	408.0	450	575.6	450	—	—	—	—	—	—	—	—
275	208/230-60	187	253	—	—	—	—	—	—	—	—	—	—	—	—
	380-60	342	418	659.2	700	912.6	700	—	—	—	—	—	—	—	—
	460-60	414	506	554.4	600	762.4	600	—	—	—	—	—	—	—	—
	575-60	518	633	450.5	500	618.1	500	—	—	—	—	—	—	—	—
300	208/230-60	187	253	—	—	—	—	—	—	—	—	—	—	—	—
	380-60	342	418	721.6	800	975.0	800	—	—	—	—	—	—	—	—
	460-60	414	506	606.8	700	814.8	700	—	—	—	—	—	—	—	—
	575-60	518	633	493.0	500	660.7	500	—	—	—	—	—	—	—	—

**LEGEND**

**AWG** — American Wire Gage      **MOCP** — Maximum Overcurrent Protection  
**ICF** — Instantaneous Current Flow      **XL** — Across-the-Line Start  
**MCA** — Minimum Circuit Amps

**NOTES:**

- Units are suitable for use on electrical systems where voltage supplied to the unit terminals is not below or above the listed minimum and maximum limits. Maximum allowable phase imbalance is: voltage, 2%; amps 10%.
- All units or modules have single point primary power connection. (Each unit or module requires its own power supply.) Main power must be supplied from a field-supplied disconnect.
- Cooler heater is wired into the control circuit so it is always operable as long as the power supply disconnect is on, even if any safety device is open.
- For MCA that is less than or equal to 380 amps, 3 conductors are required.  
 For MCA between 381-760 amps, 6 conductors are required.  
 For MCA between 761-1140 amps, 9 conductors are required.  
 For MCA between 1141-1520 amps, 12 conductors are required.  
 Calculation of conductors required is based on 75 C copper wire.

- Wiring for main field supply must be rated 75 C minimum. Use copper for all units.
  - Incoming wire size range for the terminal block is #4 AWG to 500 kcmil.
  - Incoming wire size range of non-fused disconnect with MCA up to 599.9 amps is 3/0 to 500 kcmil.
  - Incoming wire size range of non-fused disconnect with MCA from 600 to 799.9 amps is 1/0 to 500 kcmil.
  - Incoming wire size range of non-fused disconnect with MCA from 800 to 1199.9 amps is 250 kcmil to 500 kcmil.
- Hydronic pump packages are not available as a factory-installed option for units 30RB210-390.
- Power draw includes both crankcase heaters and cooler heaters (where used). Each compressor has a crankcase heater which draws 56 watts of power. Units ordered with the cooler heater option have 1 (060-150) or 2 (160-300) cooler heaters, 825 watts each.



208/230  
460  
575 v only

**Table 8 — 30RB Electrical Data — Single Point Units (cont)**

UNIT 30RB	UNIT VOLTAGE				NO HYDRONIC PACKAGE				3 HP PUMP, 1750 RPM				5 HP PUMP, 1750 RPM			
	V-Hz (3 Ph)	Supplied		MCA	MOCP	ICF	Rec Fuse Size	MCA	MOCP	ICF	Rec Fuse Size	MCA	MOCP	ICF	Rec Fuse Size	
		Min	Max	XL	XL	XL		XL	XL	XL		XL	XL	XL		
315	A	208/230-60	187	253	744.8	800	1187.0	800	—	—	—	—	—	—	—	
		380-60	342	418	390.1	400	643.5	400	—	—	—	—	—	—		
		460-60	414	506	328.9	350	536.9	350	—	—	—	—	—	—		
		575-60	518	633	265.9	300	433.5	300	—	—	—	—	—	—		
	B	208/230-60	187	253	744.8	800	1187.0	800	—	—	—	—	—	—	—	
		380-60	342	418	390.1	400	643.5	400	—	—	—	—	—	—		
460-60		414	506	328.9	350	536.9	350	—	—	—	—	—	—			
575-60		518	633	265.9	300	433.5	300	—	—	—	—	—	—			
330	A	208/230-60	187	253	802.4	1000	1244.6	1000	—	—	—	—	—	—	—	
		380-60	342	418	422.8	450	676.2	450	—	—	—	—	—	—		
		460-60	414	506	355.6	400	563.6	400	—	—	—	—	—	—		
		575-60	518	633	289.0	300	456.6	300	—	—	—	—	—	—		
	B	208/230-60	187	253	744.8	800	1187.0	800	—	—	—	—	—	—	—	
		380-60	342	418	390.1	400	643.5	400	—	—	—	—	—	—		
460-60		414	506	328.9	350	536.9	350	—	—	—	—	—	—			
575-60		518	633	265.9	300	433.5	300	—	—	—	—	—	—			
345	A	208/230-60	187	253	802.4	1000	1244.6	1000	—	—	—	—	—	—	—	
		380-60	342	418	422.8	450	676.2	450	—	—	—	—	—	—		
		460-60	414	506	355.6	400	563.6	400	—	—	—	—	—	—		
		575-60	518	633	289.0	300	456.6	300	—	—	—	—	—	—		
	B	208/230-60	187	253	802.4	1000	1244.6	1000	—	—	—	—	—	—	—	
		380-60	342	418	422.8	450	676.2	450	—	—	—	—	—	—		
460-60		414	506	355.6	400	563.6	400	—	—	—	—	—	—			
575-60		518	633	289.0	300	456.6	300	—	—	—	—	—	—			
360	A	208/230-60	187	253	920.5	1000	1362.7	1000	—	—	—	—	—	—	—	
		380-60	342	418	485.2	500	738.5	500	—	—	—	—	—	—		
		460-60	414	506	408.0	450	616.0	450	—	—	—	—	—	—		
		575-60	518	633	331.5	350	499.1	350	—	—	—	—	—	—		
	B	208/230-60	187	253	802.4	1000	1244.6	1000	—	—	—	—	—	—	—	
		380-60	342	418	422.8	450	676.2	450	—	—	—	—	—	—		
460-60		414	506	355.6	400	563.6	400	—	—	—	—	—	—			
575-60		518	633	289.0	300	456.6	300	—	—	—	—	—	—			
390	A	208/230-60	187	253	920.5	1000	1362.7	1000	—	—	—	—	—	—	—	
		380-60	342	418	485.2	500	738.5	500	—	—	—	—	—	—		
		460-60	414	506	408.0	450	616.0	450	—	—	—	—	—	—		
		575-60	518	633	331.5	350	499.1	350	—	—	—	—	—	—		
	B	208/230-60	187	253	920.5	1000	1362.7	1000	—	—	—	—	—	—	—	
		380-60	342	418	485.2	500	738.5	500	—	—	—	—	—	—		
460-60		414	506	408.0	450	616.0	450	—	—	—	—	—	—			
575-60		518	633	331.5	350	499.1	350	—	—	—	—	—	—			

**LEGEND**

**AWG** — American Wire Gage      **MOCP** — Maximum Overcurrent Protection  
**ICF** — Instantaneous Current Flow      **XL** — Across-the-Line Start  
**MCA** — Minimum Circuit Amps

**NOTES:**

- Units are suitable for use on electrical systems where voltage supplied to the unit terminals is not below or above the listed minimum and maximum limits. Maximum allowable phase imbalance is: voltage, 2%; amps 10%.
- All units or modules have single point primary power connection. (Each unit or module requires its own power supply.) Main power must be supplied from a field-supplied disconnect.
- Cooler heater is wired into the control circuit so it is always operable as long as the power supply disconnect is on, even if any safety device is open.
- For MCA that is less than or equal to 380 amps, 3 conductors are required.  
 For MCA between 381-760 amps, 6 conductors are required.  
 For MCA between 761-1140 amps, 9 conductors are required.  
 For MCA between 1141-1520 amps, 12 conductors are required.  
 Calculation of conductors required is based on 75 C copper wire.

- Wiring for main field supply must be rated 75 C minimum. Use copper for all units.
  - Incoming wire size range for the terminal block is #4 AWG to 500 kcmil.
  - Incoming wire size range of non-fused disconnect with MCA up to 599.9 amps is 3/0 to 500 kcmil.
  - Incoming wire size range of non-fused disconnect with MCA from 600 to 799.9 amps is 1/0 to 500 kcmil.
  - Incoming wire size range of non-fused disconnect with MCA from 800 to 1199.9 amps is 250 kcmil to 500 kcmil.
- Hydronic pump packages are not available as a factory-installed option for units 30RB210-390.
- Power draw includes both crankcase heaters and cooler heaters (where used). Each compressor has a crankcase heater which draws 56 watts of power. Units ordered with the cooler heater option have 1 (060-150) or 2 (160-300) cooler heaters, 825 watts each.



**Table 8 — 30RB Electrical Data — Single Point Units (cont)**

UNIT 30RB	UNIT VOLTAGE		7.5 HP PUMP, 1750/3450 RPM				10 HP PUMP, 3450 RPM				15 HP PUMP, 3450 RPM				
	V-Hz (3 Ph)	Supplied		MCA	MOCP	ICF	Rec Fuse Size	MCA	MOCP	ICF	Rec Fuse Size	MCA	MOCP	ICF	Rec Fuse Size
		Min	Max	XL	XL	XL	XL	XL	XL	XL	XL	XL	XL	XL	XL
060	208/230-60	187	253	317.2	350	708.5	350	325.1	400	716.4	350	—	—	—	—
	380-60	342	418	165.0	200	376.9	175	169.3	200	381.3	200	—	—	—	—
	460-60	414	506	139.5	150	313.6	150	143.1	175	317.2	175	—	—	—	—
	575-60	518	633	111.7	125	254.0	125	114.6	125	256.9	125	—	—	—	—
070	208/230-60	187	253	360.4	450	802.7	400	368.3	450	810.6	400	—	—	—	—
	380-60	342	418	189.5	225	442.8	225	193.9	225	447.2	225	—	—	—	—
	460-60	414	506	159.5	200	367.5	175	163.1	200	371.1	175	—	—	—	—
	575-60	518	633	129.0	150	296.7	150	131.9	150	299.6	150	—	—	—	—
080	208/230-60	187	253	392.2	450	783.5	450	400.1	450	791.4	450	416.3	450	807.6	450
	380-60	342	418	203.4	225	415.3	225	207.7	225	419.7	225	216.6	250	428.5	250
	460-60	414	506	172.2	200	346.3	200	175.8	200	349.9	200	183.1	200	357.2	200
	575-60	518	633	137.9	150	280.2	150	140.8	150	283.1	150	146.6	150	288.9	150
090	208/230-60	187	253	459.3	500	901.6	500	467.2	500	909.5	500	483.4	500	925.7	500
	380-60	342	418	241.0	250	494.3	250	245.3	250	498.7	250	254.2	300	507.5	300
	460-60	414	506	203.0	225	411.0	225	206.6	225	414.6	225	213.9	250	421.9	225
	575-60	518	633	163.9	175	331.5	175	166.8	200	334.4	200	172.6	200	340.2	200
100	208/230-60	187	253	497.7	500	940.0	500	505.6	600	947.9	600	521.8	600	964.1	600
	380-60	342	418	262.8	300	516.1	300	267.1	300	520.5	300	276.0	300	529.3	300
	460-60	414	506	220.8	250	428.8	250	224.4	250	432.4	250	231.7	250	439.7	250
	575-60	518	633	179.3	200	346.9	200	182.2	200	349.8	200	188.0	200	355.6	200
110	208/230-60	187	253	534.3	600	976.6	600	542.2	600	984.5	600	558.4	600	1000.7	600
	380-60	342	418	279.4	300	532.7	300	283.7	300	537.1	300	292.6	300	545.9	300
	460-60	414	506	235.7	250	443.7	250	239.3	250	447.3	250	246.6	250	454.6	250
	575-60	518	633	190.1	200	357.7	200	193.0	225	360.6	225	198.8	225	366.4	225
120	208/230-60	187	253	603.8	700	1046.1	600	611.8	700	1054.0	700	627.9	700	1070.2	700
	380-60	342	418	318.6	350	572.0	350	323.0	350	576.4	350	331.8	350	585.2	350
	460-60	414	506	267.8	300	425.8	300	271.4	300	479.4	300	278.7	300	486.7	300
	575-60	518	633	217.5	250	385.1	250	220.4	250	388.0	250	226.2	250	393.8	250
130	208/230-60	187	253	652.3	700	1094.6	700	660.3	700	1102.5	700	676.4	700	1118.7	700
	380-60	342	418	341.8	350	595.1	350	346.1	350	599.5	350	355.0	400	608.3	400
	460-60	414	506	288.1	300	496.1	300	291.7	300	499.7	300	299.0	300	507.0	300
	575-60	518	633	232.6	250	400.3	250	235.5	250	403.2	250	241.3	250	409.0	250
150	208/230-60	187	253	709.9	800	1152.2	800	717.9	800	1160.1	800	734.0	800	1176.3	800
	380-60	342	418	374.5	400	627.8	400	378.8	400	632.2	400	387.7	400	641.0	400
	460-60	414	506	314.8	350	522.8	350	318.4	350	526.4	350	325.7	350	533.7	350
	575-60	518	633	255.7	300	423.4	300	258.6	300	426.3	300	264.4	300	432.1	300
160	208/230-60	187	253	770.4	800	1212.7	800	778.4	800	1220.6	800	794.5	800	1236.8	800
	380-60	342	418	404.1	450	657.5	450	408.5	450	661.9	450	417.3	450	670.7	450
	460-60	414	506	340.5	350	548.5	350	344.1	350	552.1	350	351.4	400	559.4	400
	575-60	518	633	275.2	300	442.8	300	278.0	300	445.7	300	283.9	300	451.5	300
170	208/230-60	187	253	828.0	1000	1270.3	1000	836.0	1000	1278.2	1000	852.1	1000	1294.4	1000
	380-60	342	418	436.8	450	690.2	450	441.2	450	694.6	450	450.0	500	703.4	500
	460-60	414	506	367.2	400	575.2	400	370.8	400	578.8	400	378.1	400	586.1	400
	575-60	518	633	298.3	300	465.9	300	301.1	350	468.8	350	307.0	350	474.6	350
190	208/230-60	187	253	946.1	1000	1388.4	1000	954.1	1000	1396.3	1000	970.2	1000	1412.5	1000
	380-60	342	418	499.2	500	752.5	500	503.6	600	756.9	600	512.4	600	765.7	600
	460-60	414	506	419.6	450	627.6	450	423.2	450	631.2	450	430.5	450	638.5	450
	575-60	518	633	340.8	350	508.4	350	343.7	350	511.3	350	349.5	350	517.1	350

**LEGEND**

**AWG** — American Wire Gauge      **MOCP** — Maximum Overcurrent Protection  
**ICF** — Instantaneous Current Flow      **XL** — Across-the-Line Start  
**MCA** — Minimum Circuit Amps

**NOTES:**

- Units are suitable for use on electrical systems where voltage supplied to the unit terminals is not below or above the listed minimum and maximum limits. Maximum allowable phase imbalance is: voltage, 2%; amps 10%.
- All units and modules have single point primary power connection. (Each unit or module requires its own power supply.) Main power must be supplied from a field-supplied disconnect.
- Cooler heater is wired into the control circuit so it is always operable as long as the power supply disconnect is on, even if any safety device is open.
- For MCA that is less than or equal to 380 amps, 3 conductors are required.  
 For MCA between 381-760 amps, 6 conductors are required.  
 For MCA between 761-1140 amps, 9 conductors are required.  
 For MCA between 1141-1520 amps, 12 conductors are required.  
 Calculation of conductors required is based on 75 C copper wire.

- Wiring for main field supply must be rated 75 C minimum. Use copper for all units.
  - Incoming wire size range for the terminal block is #4 AWG to 500 kcmil.
  - Incoming wire size range of non-fused disconnect with MCA up to 599.9 amps is 3/0 to 500 kcmil.
  - Incoming wire size range of non-fused disconnect with MCA from 600 to 799.9 amps is 1/0 to 500 kcmil.
  - Incoming wire size range of non-fused disconnect with MCA from 800 to 1199.9 amps is 250 kcmil to 500 kcmil.
- Hydronic pump packages are not available as a factory-installed option for units 30RB210-390.
- Power draw includes both crankcase heaters and cooler heaters (where used). Each compressor has a crankcase heater which draws 56 watts of power. Units ordered with the cooler heater option have 1 (060-150) or 2 (160-300) cooler heaters, 825 watts each.



208/230  
460  
575 v only

### Table 9 — 30RB Electrical Data — Dual Point Units

30RB UNIT SIZE	UNIT VOLTAGE		NO HYDRONIC PACKAGE				3 HP PUMP, 1750 RPM				5 HP PUMP, 1750 RPM				
	V-Hz (3 Ph)	Supplied		MCA	MOCP	ICF	Rec Fuse Size	MCA	MOCP	ICF	Rec Fuse Size	MCA	MOCP	ICF	Rec Fuse Size
		Min	Max												
060	208/230-60	187	253	168.8/141.5	225/200	560.0/532.8	200/175	179.6/141.5	250/200	570.8/532.8	200/175	186.4/141.5	250/200	577.7/532.8	225/175
	380-60	342	418	86.4/ 74.1	110/110	298.4/286.1	100/ 90	92.3/ 74.1	125/110	304.3/286.1	110/ 90	96.1/ 74.1	125/110	308.1/286.1	110/ 90
	460-60	414	506	73.6/ 62.5	100/ 90	247.7/236.6	90/ 80	78.5/ 62.5	110/ 90	252.6/236.6	90/ 80	81.6/ 62.5	110/ 90	255.7/236.6	90/ 80
	575-60	518	633	59.0/ 50.0	80/ 70	201.2/192.3	70/ 60	62.9/ 50.0	80/ 70	205.1/192.3	70/ 60	65.4/ 50.0	90/ 70	207.6/192.3	80/ 60
070	208/230-60	187	253	212.0/141.5	300/200	654.2/532.8	250/175	222.8/141.5	300/200	665.0/532.8	250/175	229.6/141.5	300/200	671.9/532.8	300/175
	380-60	342	418	110.9/ 74.1	150/110	364.3/286.1	125/ 90	116.9/ 74.1	150/110	370.2/286.1	150/ 90	120.6/ 74.1	150/110	374.0/286.1	150/ 90
	460-60	414	506	93.6/ 62.5	125/ 90	301.6/236.6	110/ 80	98.5/ 62.5	125/ 90	306.5/236.6	110/ 80	101.6/ 62.5	125/ 90	309.6/236.6	125/ 80
	575-60	518	633	76.3/ 50.0	110/ 70	243.9/192.3	90/ 60	80.2/ 50.0	110/ 70	247.8/192.3	90/ 60	82.7/ 50.0	110/ 70	250.3/192.3	100/ 60
080	208/230-60	187	253	216.5/168.8	250/225	607.8/560.0	250/200	—	—	—	—	234.2/168.8	300/225	625.5/560.0	300/200
	380-60	342	418	112.5/ 86.4	150/110	324.5/298.4	125/100	—	—	—	—	122.2/ 86.4	150/110	334.2/298.4	150/100
	460-60	414	506	95.2/ 73.6	125/100	269.3/247.7	110/ 90	—	—	—	—	103.2/ 73.6	125/100	277.3/247.7	125/ 90
	575-60	518	633	76.2/ 59.0	100/ 80	218.5/201.2	90/ 70	—	—	—	—	82.6/ 59.0	100/ 80	224.9/201.2	90/ 70
090	208/230-60	187	253	283.6/168.8	350/225	725.9/560.0	350/200	—	—	—	—	301.3/168.8	350/225	743.5/560.0	350/200
	380-60	342	418	150.1/ 86.4	175/110	403.5/298.4	175/100	—	—	—	—	159.8/ 86.4	200/110	413.2/298.4	175/100
	460-60	414	506	126.0/ 73.6	150/100	334.0/247.7	150/ 90	—	—	—	—	134.0/ 73.6	175/100	342.0/247.7	150/ 90
	575-60	518	633	102.2/ 59.0	125/ 80	269.8/201.2	125/ 70	—	—	—	—	108.6/ 59.0	125/ 80	276.2/201.2	125/ 70
100	208/230-60	187	253	283.6/212.0	350/300	725.9/654.2	350/250	—	—	—	—	301.3/212.0	350/300	743.5/654.2	350/250
	380-60	342	418	150.1/110.9	175/150	403.5/364.3	175/125	—	—	—	—	159.8/110.9	200/150	413.2/364.3	175/125
	460-60	414	506	126.0/ 93.6	150/125	334.0/301.6	150/110	—	—	—	—	134.0/ 93.6	175/125	342.0/301.6	150/110
	575-60	518	633	102.2/ 76.3	125/110	269.8/243.9	125/ 90	—	—	—	—	108.6/ 76.3	125/110	276.2/243.9	125/ 90
110	208/230-60	187	253	283.6/243.8	350/300	725.9/635.0	350/300	—	—	—	—	301.3/243.8	350/300	743.5/635.0	350/300
	380-60	342	418	150.1/124.8	175/150	403.5/336.8	175/150	—	—	—	—	159.8/124.8	200/150	413.2/336.8	175/150
	460-60	414	506	126.0/106.3	150/125	334.0/280.4	150/125	—	—	—	—	134.0/106.3	175/125	342.0/280.4	150/125
	575-60	518	633	102.2/ 85.2	125/110	269.8/227.4	125/100	—	—	—	—	108.6/ 85.2	125/110	276.2/227.4	125/100
120	208/230-60	187	253	295.5/306.2	350/400	737.8/748.4	350/350	—	—	—	—	313.2/306.2	400/400	755.5/748.4	350/350
	380-60	342	418	156.7/160.2	200/200	410.1/413.6	175/175	—	—	—	—	166.4/160.2	200/200	419.7/413.6	200/175
	460-60	414	506	131.4/135.2	150/175	339.4/343.2	150/150	—	—	—	—	139.4/135.2	175/175	347.4/343.2	150/150
	575-60	518	633	106.5/110.2	125/125	274.1/277.8	125/125	—	—	—	—	112.9/110.2	125/125	280.5/277.8	125/125
130	208/230-60	187	253	401.7/243.8	450/300	843.9/635.0	450/300	—	—	—	—	419.4/243.8	500/300	861.6/635.0	450/300
	380-60	342	418	212.5/124.8	250/150	465.9/336.8	225/150	—	—	—	—	222.2/124.8	250/150	475.6/336.8	250/150
	460-60	414	506	178.4/106.3	200/125	386.4/280.4	200/125	—	—	—	—	186.4/106.3	225/125	394.4/280.4	200/125
	575-60	518	633	144.7/ 85.2	175/110	312.4/227.4	175/100	—	—	—	—	151.1/ 85.2	175/110	318.8/227.4	175/100
150	208/230-60	187	253	401.7/306.2	450/400	843.9/748.4	450/350	—	—	—	—	419.4/306.2	500/400	861.6/748.4	450/350
	380-60	342	418	212.5/160.2	250/200	465.9/413.6	225/175	—	—	—	—	222.2/160.2	250/200	475.6/413.6	250/175
	460-60	414	506	178.4/135.2	200/175	386.4/343.2	200/150	—	—	—	—	186.4/135.2	225/175	394.4/343.2	200/150
	575-60	518	633	144.7/110.2	175/125	312.4/277.8	175/125	—	—	—	—	151.1/110.2	175/125	318.8/277.8	175/125
160	208/230-60	187	253	519.8/243.8	600/300	962.0/635.0	600/300	—	—	—	—	537.5/243.8	600/300	979.7/635.0	600/300
	380-60	342	418	274.9/124.8	300/150	528.3/336.8	300/150	—	—	—	—	284.6/124.8	300/150	538.0/336.8	300/150
	460-60	414	506	230.8/106.3	250/125	438.8/280.4	250/125	—	—	—	—	238.8/106.3	250/125	446.8/280.4	250/125
	575-60	518	633	187.3/ 85.2	200/110	354.9/227.4	200/100	—	—	—	—	193.7/ 85.2	225/110	361.3/227.4	225/100
170	208/230-60	187	253	519.8/306.2	600/400	962.0/748.4	600/350	—	—	—	—	537.5/306.2	600/400	979.7/748.4	600/350
	380-60	342	418	274.9/160.2	300/200	528.3/413.6	300/175	—	—	—	—	284.6/160.2	300/200	538.0/413.6	300/175
	460-60	414	506	230.8/135.2	250/175	438.8/343.2	250/150	—	—	—	—	238.8/135.2	250/175	446.8/343.2	250/150
	575-60	518	633	187.3/110.2	200/125	354.9/277.8	200/125	—	—	—	—	193.7/110.2	225/125	361.3/277.8	225/125
190	208/230-60	187	253	543.7/400.4	600/450	985.9/842.6	600/450	—	—	—	—	561.4/400.4	600/450	1003.6/842.6	600/450
	380-60	342	418	288.0/209.5	300/250	541.3/462.9	300/225	—	—	—	—	297.7/209.5	300/250	551.0/462.9	300/225
	460-60	414	506	241.6/176.8	250/200	449.6/384.8	250/200	—	—	—	—	249.6/176.8	250/200	457.6/384.8	250/200
	575-60	518	633	195.9/144.1	225/175	363.5/311.7	225/175	—	—	—	—	202.3/144.1	225/175	369.9/311.7	225/175
210	208/230-60	187	253	626.7/353.9	700/400	1068.9/796.2	700/400	—	—	—	—	—	—	—	—
	380-60	342	418	327.7/186.4	350/225	581.1/439.7	350/200	—	—	—	—	—	—	—	—
	460-60	414	506	233.3/200.0	250/225	441.3/408.0	250/225	—	—	—	—	—	—	—	—
	575-60	518	633	188.8/162.0	200/175	356.4/329.6	200/175	—	—	—	—	—	—	—	—
225	208/230-60	187	253	684.3/353.9	700/400	1126.5/796.2	700/400	—	—	—	—	—	—	—	—
	380-60	342	418	360.4/186.4	400/225	613.8/439.7	400/200	—	—	—	—	—	—	—	—
	460-60	414	506	260.0/200.0	300/225	468.0/408.0	300/225	—	—	—	—	—	—	—	—
	575-60	518	633	211.9/162.0	225/175	379.5/329.6	225/175	—	—	—	—	—	—	—	—
250	208/230-60	187	253	684.3/472.0	700/500	1126.5/914.3	700/500	—	—	—	—	—	—	—	—
	380-60	342	418	360.4/248.7	400/250	613.8/502.1	400/250	—	—	—	—	—	—	—	—
	460-60	414	506	303.2/209.2	350/250	511.2/417.2	350/225	—	—	—	—	—	—	—	—
	575-60	518	633	246.4/170.0	250/200	414.1/337.6	250/200	—	—	—	—	—	—	—	—
275	208/230-60	187	253	920.5/353.9	1000/400	1362.7/796.2	1000/400	—	—	—	—	—	—	—	—
	380-60	342	418	485.2/186.4	500/225	738.5/439.7	500/200	—	—	—	—	—	—	—	—
	460-60	414	506	408.0/156.8	450/175	616.0/364.8	450/175	—	—	—	—	—	—	—	—
	575-60	518	633	331.5/127.5	350/150	499.1/295.1	350/150	—	—	—	—	—	—	—	—
300	208/230-60	187	253	920.5/472.0	1000/500	1362.7/914.3	1000/500	—	—	—	—	—	—	—	—
	380-60	342	418	485.2/248.7	500/250	738.5/502.1	500/250	—	—	—	—	—	—	—	—
	460-60	414	506	408.0/209.2	450/250	616.0/417.2	450/225	—	—	—	—	—	—	—	—
	575-60	518	633	331.5/170.0	350/200	499.1/337.6	350/200	—	—	—	—	—	—	—	—

#### LEGEND

- AWG** — American Wire Gage  
**ICF** — Instantaneous Current Flow (Ckt1/Ckt2)  
**MCA** — Minimum Circuit Amps (Ckt1/Ckt2)  
**MOCP** — Maximum Overcurrent Protection (Ckt1/Ckt2)  
**XL** — Across-the-Line Start

#### NOTES:

1. Units are suitable for use on electrical systems where voltage supplied to the unit terminals is not below or above the listed minimum and maximum limits. Maximum allowable phase imbalance is: voltage, 2%; amps 10%.
2. Control power is derived from main power. No separate control power connection is required.
3. Cooler heater is wired into the control circuit so it is always operable as long as the power supply disconnect is on, even if any safety device is open.
4. For MCA that is less than or equal to 380 amps, 3 conductors are required.  
 For MCA between 381-760 amps, 6 conductors are required.  
 For MCA between 761-1140 amps, 9 conductors are required.  
 For MCA between 1141-1520 amps, 12 conductors are required.  
 Calculation of conductors required is based on 75 C copper wire.

5. Wiring for main field supply must be rated 75 C minimum. Use copper for all units.
  - a. Incoming wire size range for the terminal block is #4 AWG to 500 kcmil.
  - b. Incoming wire size range of non-fused disconnect with MCA up to 599.9 amps is 3/0 to 500 kcmil.
  - c. Incoming wire size range of non-fused disconnect with MCA from 600 to 799.9 amps is 1/0 to 500 kcmil

**Table 9 — 30RB Electrical Data — Dual Point Units (cont)**

30RB UNIT SIZE	UNIT VOLTAGE			NO HYDRONIC PACKAGE				3 HP PUMP, 1750 RPM				5 HP PUMP, 1750 RPM			
	V-Hz (3 Ph)	Supplied		MCA	MOCP	ICF	Rec Fuse Size	MCA	MOCP	ICF	Rec Fuse Size	MCA	MOCP	ICF	Rec Fuse Size
		Min	Max												
315	A	208/230-60	187	253	519.8/243.8	600/300	962.0/635.0	600/300	—	—	—	—	—	—	—
		380-60	342	418	274.9/124.8	300/150	528.3/336.8	300/150	—	—	—	—	—	—	—
		460-60	414	506	230.8/106.3	250/125	438.8/280.4	250/125	—	—	—	—	—	—	—
		575-60	518	633	187.3/ 85.2	200/110	354.9/227.4	200/100	—	—	—	—	—	—	—
	B	208/230-60	187	253	519.8/243.8	600/300	962.0/635.0	600/300	—	—	—	—	—	—	—
		380-60	342	418	274.9/124.8	300/150	528.3/336.8	300/150	—	—	—	—	—	—	—
		460-60	414	506	230.8/106.3	250/125	438.8/280.4	250/125	—	—	—	—	—	—	—
		575-60	518	633	187.3/ 85.2	200/110	354.9/227.4	200/100	—	—	—	—	—	—	—
330	A	208/230-60	187	253	519.8/306.2	600/400	962.0/748.4	600/350	—	—	—	—	—	—	—
		380-60	342	418	274.9/160.2	300/200	528.3/413.6	300/175	—	—	—	—	—	—	—
		460-60	414	506	230.8/135.2	250/175	438.8/343.2	250/150	—	—	—	—	—	—	—
		575-60	518	633	187.3/110.2	200/125	354.9/277.8	200/125	—	—	—	—	—	—	—
	B	208/230-60	187	253	519.8/243.8	600/300	962.0/635.0	600/300	—	—	—	—	—	—	—
		380-60	342	418	274.9/124.8	300/150	528.3/336.8	300/150	—	—	—	—	—	—	—
		460-60	414	506	230.8/106.3	250/125	438.8/280.4	250/125	—	—	—	—	—	—	—
		575-60	518	633	187.3/ 85.2	200/110	354.9/227.4	200/100	—	—	—	—	—	—	—
345	A	208/230-60	187	253	519.8/306.2	600/400	962.0/748.4	600/350	—	—	—	—	—	—	—
		380-60	342	418	274.9/160.2	300/200	528.3/413.6	300/175	—	—	—	—	—	—	—
		460-60	414	506	230.8/135.2	250/175	438.8/343.2	250/150	—	—	—	—	—	—	—
		575-60	518	633	187.3/110.2	200/125	354.9/277.8	200/125	—	—	—	—	—	—	—
	B	208/230-60	187	253	519.8/306.2	600/400	962.0/748.4	600/350	—	—	—	—	—	—	—
		380-60	342	418	274.9/160.2	300/200	528.3/413.6	300/175	—	—	—	—	—	—	—
		460-60	414	506	230.8/135.2	250/175	438.8/343.2	250/150	—	—	—	—	—	—	—
		575-60	518	633	187.3/110.2	200/125	354.9/277.8	200/125	—	—	—	—	—	—	—
360	A	208/230-60	187	253	543.7/400.4	600/450	985.9/842.6	600/450	—	—	—	—	—	—	—
		380-60	342	418	288.0/209.5	300/250	541.3/462.9	300/225	—	—	—	—	—	—	—
		460-60	414	506	241.6/176.8	250/200	449.6/384.8	250/200	—	—	—	—	—	—	—
		575-60	518	633	195.9/144.1	225/175	363.5/311.7	225/175	—	—	—	—	—	—	—
	B	208/230-60	187	253	519.8/306.2	600/400	962.0/748.4	600/350	—	—	—	—	—	—	—
		380-60	342	418	274.9/160.2	300/200	528.3/413.6	300/175	—	—	—	—	—	—	—
		460-60	414	506	230.8/135.2	250/175	438.8/343.2	250/150	—	—	—	—	—	—	—
		575-60	518	633	187.3/110.2	200/125	354.9/277.8	200/125	—	—	—	—	—	—	—
390	A	208/230-60	187	253	543.7/400.4	600/450	985.9/842.6	600/450	—	—	—	—	—	—	—
		380-60	342	418	288.0/209.5	300/250	541.3/462.9	300/225	—	—	—	—	—	—	—
		460-60	414	506	241.6/176.8	250/200	449.6/384.8	250/200	—	—	—	—	—	—	—
		575-60	518	633	195.9/144.1	225/175	363.5/311.7	225/175	—	—	—	—	—	—	—
	B	208/230-60	187	253	543.7/400.4	600/450	985.9/842.6	600/450	—	—	—	—	—	—	—
		380-60	342	418	288.0/209.5	300/250	541.3/462.9	300/225	—	—	—	—	—	—	—
		460-60	414	506	241.6/176.8	250/200	449.6/384.8	250/200	—	—	—	—	—	—	—
		575-60	518	633	195.9/144.1	225/175	363.5/311.7	225/175	—	—	—	—	—	—	—

**LEGEND**

- AWG** — American Wire Gauge
- ICF** — Instantaneous Current Flow (Ckt1/Ckt2)
- MCA** — Minimum Circuit Amps (Ckt1/Ckt2)
- MOCP** — Maximum Overcurrent Protection (Ckt1/Ckt2)
- XL** — Across-the-Line Start

**NOTES:**

1. Units are suitable for use on electrical systems where voltage supplied to the unit terminals is not below or above the listed minimum and maximum limits. Maximum allowable phase imbalance is: voltage, 2%; amps 10%.
2. Control power is derived from main power. No separate control power connection is required.
3. Cooler heater is wired into the control circuit so it is always operable as long as the power supply disconnect is on, even if any safety device is open.
4. For MCA that is less than or equal to 380 amps, 3 conductors are required.  
For MCA between 381-760 amps, 6 conductors are required.  
For MCA between 761-1140 amps, 9 conductors are required.  
For MCA between 1141-1520 amps, 12 conductors are required.  
Calculation of conductors required is based on 75 C copper wire.

5. Wiring for main field supply must be rated 75 C minimum. Use copper for all units.
  - a. Incoming wire size range for the terminal block is #4 AWG to 500 kcmil.
  - b. Incoming wire size range of non-fused disconnect with MCA up to 599.9 amps is 3/0 to 500 kcmil.
  - c. Incoming wire size range of non-fused disconnect with MCA from 600 to 799.9 amps is 1/0 to 500 kcmil.
  - d. Incoming wire size range of non-fused disconnect with MCA from 800 to 1199.9 amps is 250 kcmil to 500 kcmil.
6. Hydronic pump packages are not available as a factory-installed option for units 30RB210-390.
7. Power draw includes both crankcase heaters and cooler heaters (where used). Each compressor has a crankcase heater which draws 56 watts of power. Units ordered with the cooler heater option have 1 (060-150) or 2 (160-300) cooler heaters, 825 watts each.





Table 9 — 30RB Electrical Data — Dual Point Units (cont)

30RB UNIT SIZE	UNIT VOLTAGE		7.5 HP PUMP, 1750/3450 RPM				10 HP PUMP, 3450 RPM				15 HP PUMP, 3450 RPM			
	V-Hz (3 Ph)	Supplied Min Max	MCA	MOCP	ICF	Rec Fuse Size	MCA	MOCP	ICF	Rec Fuse Size	MCA	MOCP	ICF	Rec Fuse Size
060	208/230-60	187 253	194.4/141.5	250/200	585.7/532.8	225/175	202.4/141.5	250/200	593.6/532.8	225/175	—	—	—	—
	380-60	342 418	100.4/ 74.1	125/110	312.4/286.1	125/ 90	104.8/ 74.1	125/110	316.8/286.1	125/ 90	—	—	—	—
	460-60	414 506	85.2/ 62.5	110/ 90	259.3/236.6	100/ 80	88.8/ 62.5	110/ 90	262.9/236.6	100/ 80	—	—	—	—
	575-60	518 633	68.2/ 50.0	90/ 70	210.5/192.3	80/ 60	71.1/ 50.0	90/ 70	213.4/192.3	80/ 60	—	—	—	—
070	208/230-60	187 253	237.6/141.5	300/200	679.9/532.8	300/175	245.6/141.5	300/200	687.8/532.8	300/175	—	—	—	—
	380-60	342 418	125.0/ 74.1	150/110	378.3/286.1	150/ 90	129.3/ 74.1	175/110	382.7/286.1	150/ 90	—	—	—	—
	460-60	414 506	105.2/ 62.5	125/ 90	313.2/236.6	125/ 80	108.8/ 62.5	150/ 90	316.9/236.6	125/ 80	—	—	—	—
	575-60	518 633	85.6/ 50.0	110/ 70	253.2/192.3	100/ 60	88.4/ 50.0	110/ 70	256.1/192.3	100/ 60	—	—	—	—
080	208/230-60	187 253	242.2/168.8	300/225	633.4/560.0	300/200	250.1/168.8	300/225	641.4/560.0	300/200	266.3/168.8	300/225	657.5/560.0	300/200
	380-60	342 418	126.6/ 86.4	150/110	338.6/298.4	150/100	130.9/ 86.4	150/110	342.9/298.4	150/100	139.8/ 86.4	175/110	351.8/298.4	150/100
	460-60	414 506	106.8/ 73.6	125/100	280.9/247.7	125/ 90	110.4/ 73.6	125/100	284.5/247.7	125/ 90	117.7/ 73.6	150/100	291.8/247.7	150/ 90
	575-60	518 633	85.5/ 59.0	110/ 80	227.8/201.2	100/ 70	88.4/ 59.0	110/ 80	230.6/201.2	100/ 70	94.2/ 59.0	150/ 80	236.5/201.2	110/ 70
090	208/230-60	187 253	309.3/168.8	400/225	751.5/560.0	350/200	317.2/168.8	400/225	759.5/560.0	350/200	333.4/168.8	400/225	775.6/560.0	400/200
	380-60	342 418	164.2/ 86.4	200/110	417.6/298.4	200/100	168.5/ 86.4	200/110	421.9/298.4	200/100	177.4/ 86.4	225/110	430.8/298.4	200/100
	460-60	414 506	137.6/ 73.6	175/100	345.6/247.7	150/ 90	141.2/ 73.6	175/100	349.2/247.7	175/ 90	148.5/ 73.6	175/100	356.5/247.7	175/ 90
	575-60	518 633	111.5/ 59.0	125/ 80	279.1/201.2	125/ 70	114.4/ 59.0	125/ 80	282.0/201.2	125/ 70	120.2/ 59.0	150/ 80	287.8/201.2	150/ 70
100	208/230-60	187 253	309.3/212.0	400/300	751.5/654.2	350/250	317.2/212.0	400/300	759.5/654.2	350/250	333.4/212.0	400/300	775.6/654.2	400/250
	380-60	342 418	164.2/110.9	200/150	417.6/364.3	200/125	168.5/110.9	200/150	421.9/364.3	200/125	177.4/110.9	225/150	430.8/364.3	200/125
	460-60	414 506	137.6/ 93.6	175/125	345.6/301.6	150/110	141.2/ 93.6	175/125	349.2/301.6	175/110	148.5/ 93.6	175/125	356.5/301.6	175/110
	575-60	518 633	111.5/ 76.3	125/110	279.1/243.9	125/ 90	114.4/ 76.3	125/110	282.0/243.9	125/ 90	120.2/ 76.3	150/110	287.8/243.9	150/ 90
110	208/230-60	187 253	309.3/243.8	400/300	751.5/635.0	350/300	317.2/243.8	400/300	759.5/635.0	350/300	333.4/243.8	400/300	775.6/635.0	400/300
	380-60	342 418	164.2/124.8	200/150	417.6/336.8	200/150	168.5/124.8	200/150	421.9/336.8	200/150	177.4/124.8	225/150	430.8/336.8	200/150
	460-60	414 506	137.6/106.3	175/125	345.6/280.4	150/125	141.2/106.3	175/125	349.2/280.4	175/125	148.5/106.3	175/125	356.5/280.4	175/125
	575-60	518 633	111.5/ 85.2	125/110	279.1/227.4	125/100	114.4/ 85.2	125/110	282.0/227.4	125/100	120.2/ 85.2	150/110	287.8/227.4	150/100
120	208/230-60	187 253	321.2/306.2	400/400	763.5/748.4	350/350	329.2/306.2	400/400	771.4/748.4	400/350	345.3/306.2	400/400	787.6/748.4	400/350
	380-60	342 418	170.7/160.2	200/200	424.1/413.6	200/175	175.1/160.2	200/200	428.5/413.6	200/175	183.9/160.2	225/200	437.3/413.6	200/175
	460-60	414 506	143.0/135.2	175/175	351.0/343.2	175/150	146.6/135.2	175/175	354.6/343.2	175/150	153.9/135.2	175/175	361.9/343.2	175/150
	575-60	518 633	115.8/110.2	125/125	283.4/277.8	125/125	118.7/110.2	150/125	286.3/277.8	150/125	124.5/110.2	150/125	292.1/277.8	150/125
130	208/230-60	187 253	321.2/306.2	500/300	869.6/635.0	500/300	435.3/243.8	500/300	877.6/635.0	500/300	451.4/243.8	500/300	893.7/635.0	500/300
	380-60	342 418	226.6/124.8	250/150	479.9/336.8	250/150	230.9/124.8	250/150	484.3/336.8	250/150	239.8/124.8	250/150	493.1/336.8	250/150
	460-60	414 506	190.0/106.3	225/125	398.0/280.4	225/125	193.6/106.3	225/125	401.6/280.4	225/125	200.9/106.3	225/125	408.9/280.4	225/125
	575-60	518 633	154.0/ 85.2	175/110	321.6/227.4	175/100	156.9/ 85.2	175/110	324.5/227.4	175/100	162.7/ 85.2	175/110	330.4/227.4	175/100
150	208/230-60	187 253	427.3/306.2	500/400	869.6/748.4	500/350	435.3/306.2	500/400	877.6/748.4	500/350	451.4/306.2	500/400	893.7/748.4	500/350
	380-60	342 418	226.6/160.2	250/200	479.9/413.6	250/175	230.9/160.2	250/200	484.3/413.6	250/175	239.8/160.2	250/200	493.1/413.6	250/175
	460-60	414 506	190.0/135.2	225/175	398.0/343.2	225/150	193.6/135.2	225/175	401.6/343.2	225/150	200.9/135.2	225/175	408.9/343.2	225/150
	575-60	518 633	154.0/110.2	175/125	321.6/277.8	175/125	156.9/110.2	175/125	324.5/277.8	175/125	162.7/110.2	175/125	330.4/277.8	175/125
160	208/230-60	187 253	545.4/243.8	600/300	987.7/635.0	600/300	553.4/243.8	600/300	995.6/635.0	600/300	569.5/243.8	600/300	1011.8/635.0	600/300
	380-60	342 418	288.9/124.8	300/150	542.3/336.8	300/150	293.3/124.8	300/150	546.7/336.8	300/150	302.1/124.8	350/150	555.5/336.8	350/150
	460-60	414 506	242.4/106.3	250/125	450.4/280.4	250/125	246.0/106.3	250/125	454.0/280.4	250/125	253.3/106.3	300/125	461.3/280.4	300/125
	575-60	518 633	196.6/ 85.2	225/110	364.2/227.4	225/100	199.4/ 85.2	225/110	367.1/227.4	225/100	205.3/ 85.2	225/100	372.9/227.4	225/100
170	208/230-60	187 253	545.4/306.2	600/400	987.7/748.4	600/350	553.4/306.2	600/400	995.6/748.4	600/350	569.5/306.2	600/400	1011.8/748.4	600/350
	380-60	342 418	288.9/160.2	300/200	542.3/413.6	300/175	293.3/160.2	300/200	546.7/413.6	300/175	302.1/160.2	350/200	555.5/413.6	350/175
	460-60	414 506	242.4/135.2	250/175	450.4/343.2	250/150	246.0/135.2	250/175	454.0/343.2	250/150	253.3/135.2	300/175	461.3/343.2	300/150
	575-60	518 633	196.6/110.2	225/125	364.2/277.8	225/125	199.4/110.2	225/125	367.1/277.8	225/125	205.3/110.2	225/125	372.9/277.8	225/125
190	208/230-60	187 253	569.3/400.4	600/450	1011.6/842.6	600/450	577.3/400.4	600/450	1019.5/842.6	600/450	593.4/400.4	600/450	1035.7/842.6	600/450
	380-60	342 418	302.0/209.5	350/250	555.4/462.9	350/225	306.4/209.5	350/250	559.7/462.9	350/225	315.2/209.5	350/250	568.6/462.9	350/225
	460-60	414 506	253.2/176.8	300/200	461.2/384.8	300/200	256.8/176.8	300/200	464.8/384.8	300/200	264.1/176.8	300/200	472.1/384.8	300/200
	575-60	518 633	205.2/144.1	225/175	372.8/311.7	225/175	208.1/144.1	225/175	375.7/311.7	225/175	213.9/144.1	225/175	381.5/311.7	225/175

LEGEND

- AWG — American Wire Gauge
- ICF — Instantaneous Current Flow (Ckt1/Ckt2)
- MCA — Minimum Circuit Amps (Ckt1/Ckt2)
- MOCP — Maximum Overcurrent Protection (Ckt1/Ckt2)
- XL — Across-the-Line Start

NOTES:

1. Units are suitable for use on electrical systems where voltage supplied to the unit terminals is not below or above the listed minimum and maximum limits. Maximum allowable phase imbalance is: voltage, 2%; amps 10%.
2. All units/modules have single point primary power connection. (Each unit/module requires its own power supply.) Main power must be supplied from a field-supplied disconnect.
3. Cooler heater is wired into the control circuit so it is always operable as long as the power supply disconnect is on, even if any safety device is open.
4. For MCA that is less than or equal to 380 amps, 3 conductors are required.  
For MCA between 381-760 amps, 6 conductors are required.  
For MCA between 761-1140 amps, 9 conductors are required.  
For MCA between 1141-1520 amps, 12 conductors are required.  
Calculation of conductors required is based on 75 C copper wire.

5. Wiring for main field supply must be rated 75 C minimum. Use copper for all units.
  - a. Incoming wire size range for the terminal block is #4 AWG to 500 kcmil.
  - b. Incoming wire size range of non-fused disconnect with MCA up to 599.9 amps is 3/0 to 500 kcmil.
  - c. Incoming wire size range of non-fused disconnect with MCA from 600 to 799.9 amps is 1/0 to 500 kcmil.
  - d. Incoming wire size range of non-fused disconnect with MCA from 800 to 1199.9 amps is 250 kcmil to 500 kcmil.
6. Hydronic pump packages are not available as a factory-installed option for units 30RB210-390.
7. Power draw includes both crankcase heaters and cooler heaters (where used). Each compressor has a crankcase heater which draws 56 watts of power. Units ordered with the cooler heater option have 1 (060-150) or 2 (160-300) cooler heaters, 825 watts each.



208/230  
460  
575 v only

**Table 10 — Condenser Fan Electrical Data**

UNIT 30RB	UNIT VOLTAGE V-Hz (3 Ph)	STANDARD CONDENSER FANS					
		Circuit A Quantity	FLA (each)	Circuit B Quantity	FLA (each)	Circuit C Quantity	FLA (each)
060, 070	208/230-60	3	11.9	1	11.9	—	—
	460-60	3	5.4	1	5.4	—	—
	575-60	3	4.3	1	4.3	—	—
	380-60	3	6.5	1	6.5	—	—
080	208/230-60	2	11.9	2	11.9	—	—
	460-60	2	5.4	2	5.4	—	—
	575-60	2	4.3	2	4.3	—	—
	380-60	2	6.5	2	6.5	—	—
090, 100, 110	208/230-60	3	11.9	3	11.9	—	—
	460-60	3	5.4	3	5.4	—	—
	575-60	3	4.3	3	4.3	—	—
	380-60	3	6.5	3	6.5	—	—
120	208/230-60	3	11.9	4	11.9	—	—
	460-60	3	5.4	4	5.4	—	—
	575-60	3	4.3	4	4.3	—	—
	380-60	3	6.5	4	6.5	—	—
130, 150	208/230-60	4	11.9	4	11.9	—	—
	460-60	4	5.4	4	5.4	—	—
	575-60	4	4.3	4	4.3	—	—
	380-60	4	6.5	4	6.5	—	—
160,170, 315A, 315B, 330A, 330B, 345A, 345B, 360B	208/230-60	6	11.9	4	11.9	—	—
	460-60	6	5.4	4	5.4	—	—
	575-60	6	4.3	4	4.3	—	—
	380-60	6	6.5	4	6.5	—	—
190, 360A, 390A, 390B	208/230-60	6	11.9	6	11.9	—	—
	460-60	6	5.4	6	5.4	—	—
	575-60	6	4.3	6	4.3	—	—
	380-60	6	6.5	6	6.5	—	—
210, 225	208/230-60	4	11.9	4	11.9	4	11.9
	460-60	4	5.4	4	5.4	4	5.4
	575-60	4	4.3	4	4.3	4	4.3
	380-60	4	6.5	4	6.5	4	6.5
250	208/230-60	4	11.9	4	11.9	6	11.9
	460-60	4	5.4	4	5.4	6	5.4
	575-60	4	4.3	4	4.3	6	4.3
	380-60	4	6.5	4	6.5	6	6.5
275	208/230-60	6	11.9	6	11.9	4	11.9
	460-60	6	5.4	6	5.4	4	5.4
	575-60	6	4.3	6	4.3	4	4.3
	380-60	6	6.5	6	6.5	4	6.5
300	208/230-60	6	11.9	6	11.9	6	11.9
	460-60	6	5.4	6	5.4	6	5.4
	575-60	6	4.3	6	4.3	6	4.3
	380-60	6	6.5	6	6.5	6	6.5

LEGEND

FLA — Full Load Amps

**Table 11 — Pump Electrical Data**

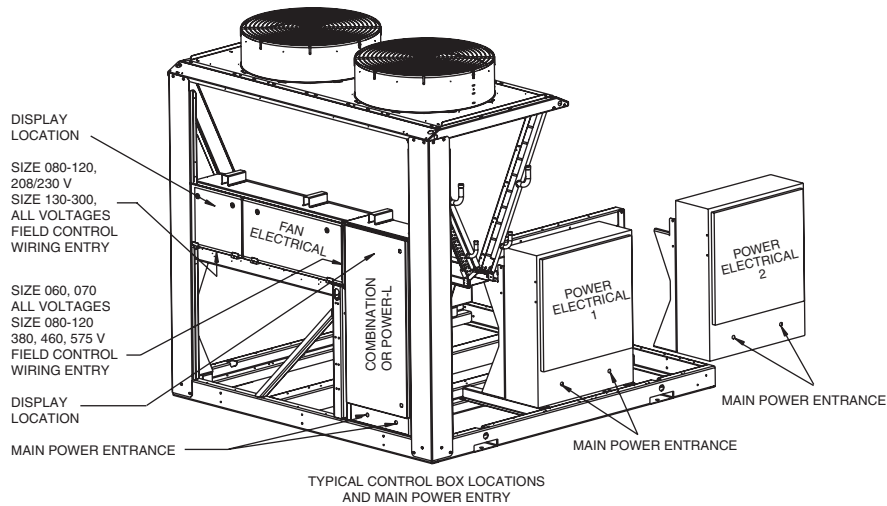
PUMP HP	UNIT VOLTAGE V-Hz (3 Ph)	HYDRONIC SYSTEM (SINGLE/DUAL) FLA (each)	USED ON 30RB SIZES*
3	208/230-60	10.8	060, 070
	460-60	4.9	
	575-60	3.9	
	380-60	5.9	
5	208/230-60	17.7	060-190
	460-60	8.0	
	575-60	6.4	
	380-60	9.7	
7.5	208/230-60	25.7	060-190
	460-60	11.6	
	575-60	9.3	
	380-60	14.0	
10	208/230-60	33.6	060-190
	460-60	15.2	
	575-60	12.2	
	380-60	18.4	
15	208/230-60	49.8	080-190
	460-60	22.5	
	575-60	18.0	
	380-60	27.2	

LEGEND

FLA — Full Load Amps

\*Hydronic pump packages are not available as a factory-installed option for units 30RB210-390.

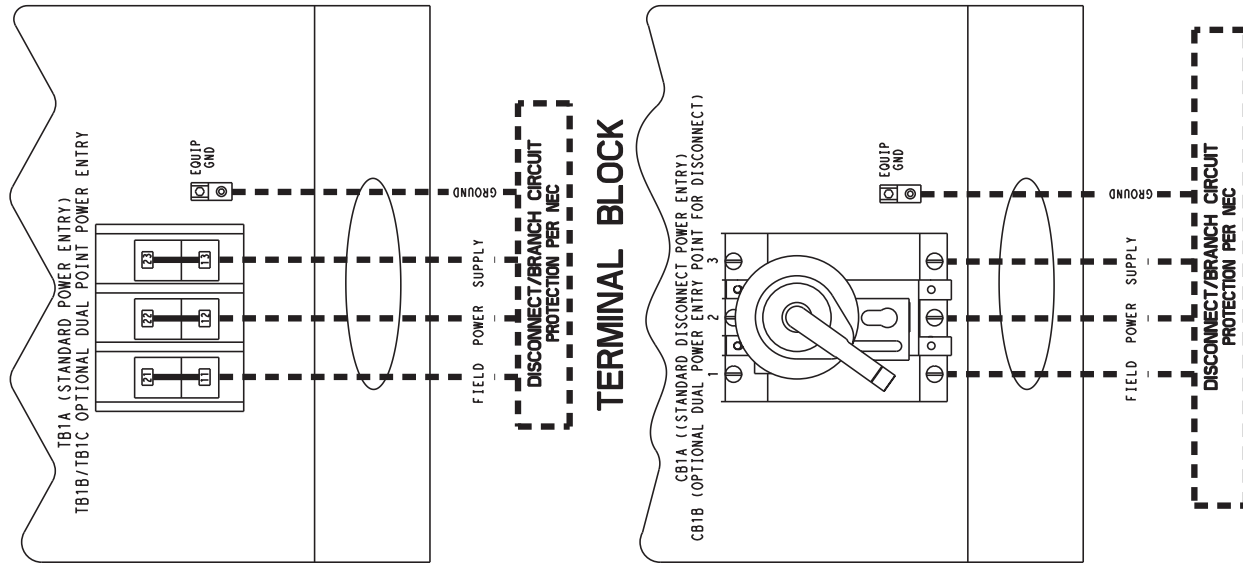




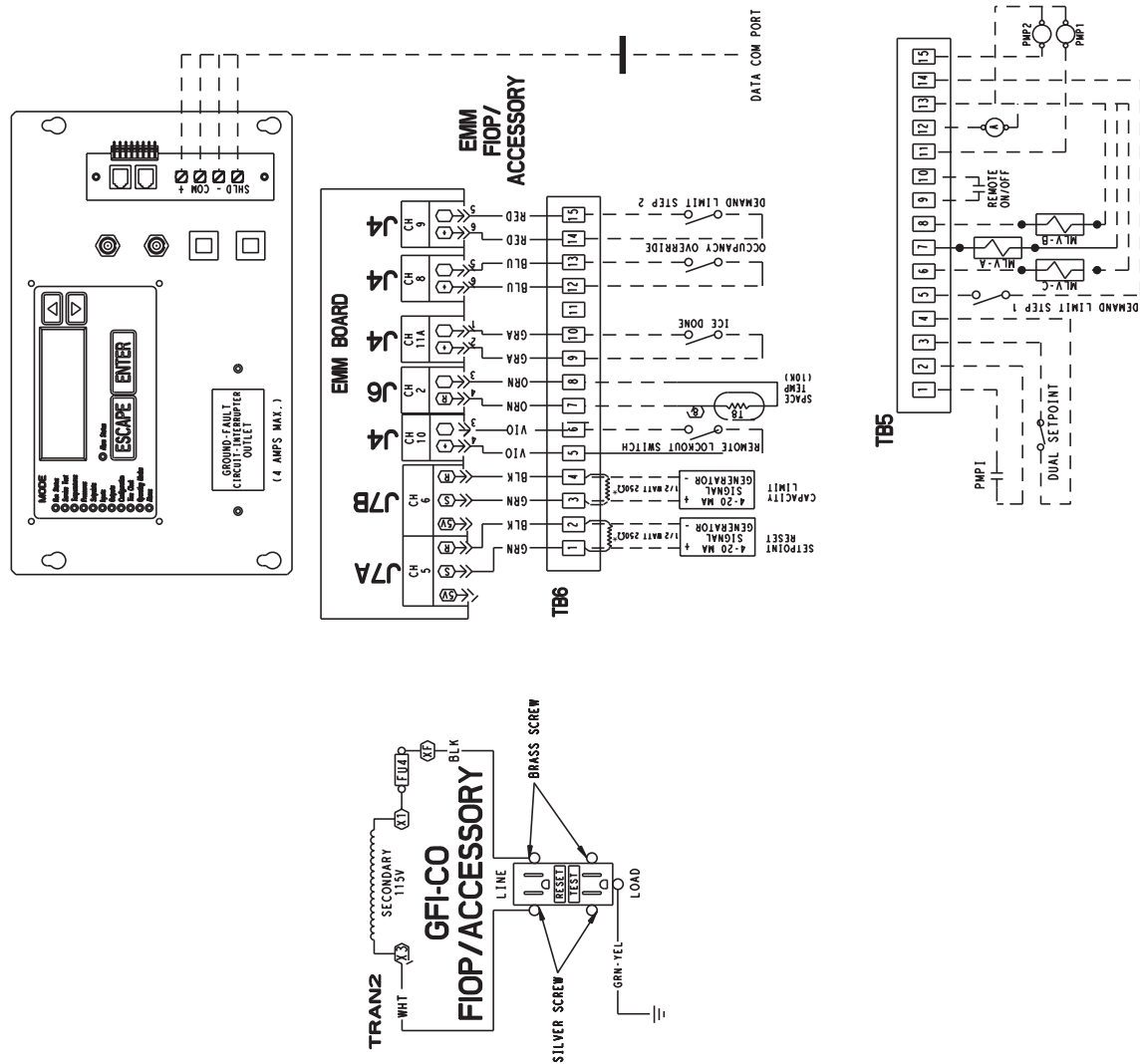
30RB UNIT SIZE	VOLTAGE	ELECTRICAL OPTION	CONNECTIONS	MAIN POWER ENTRANCE	CONTROL BOX
060,070	208/230, 380, 380, 460, 575	Standard (Terminal Block)	Single Point	Circuit 1	Combination
			Dual Point	Circuit 1	Combination
		Non-Fused Disconnect Option*	Single Point	Circuit 2	Combination
080-120	208/230	Standard (Terminal Block)	Single Point	Circuit 1	Power-L
			Dual Point	Circuit 1	Power-L
		Non-Fused Disconnect Option*	Single Point	Circuit 2	Power-L
	380, 460, 575	Standard (Terminal Block)	Single Point	Circuit 1	Combination
			Dual Point	Circuit 1	Combination
		Non-Fused Disconnect Option*	Single Point	Circuit 2	Combination
130-190, 315A-390A, 315B-390B	208/230	Standard (Terminal Block)	Single Point	Circuit 1	Power-L
			Dual Point	Circuit 1	Power-L
			Dual Point	Circuit 2	PE1
		Non-Fused Disconnect Option	Single Point	Circuit 1	Power-L
			Dual Point	Circuit 1	Power-L
			Dual Point	Circuit 2	PE1
	380, 460, 575	Standard (Terminal Block)	Single Point	Circuit 1	PE1
			Dual Point	Circuit 1	PE1
			Dual Point	Circuit 2	PE1
		Non-Fused Disconnect Option	Single Point	Circuit 1	PE1
			Dual Point	Circuit 1	PE1
			Dual Point	Circuit 2	Power-L
210, 225	208/230†	Standard (Terminal Block)	Dual Point	Circuit 1	Power-L
			Dual Point	Circuit 2	PE2
		Non-Fused Disconnect Option	Dual Point	Circuit 1	Power-L
	380, 460, 575	Standard (Terminal Block)	Single Point	Circuit 1	PE1
			Dual Point	Circuit 1	PE1
			Dual Point	Circuit 2	PE1
		Non-Fused Disconnect Option	Single Point	Circuit 1	PE1
			Dual Point	Circuit 1	PE1
			Dual Point	Circuit 2	Power-L
250-300	208/230†	Standard (Terminal Block)	Dual Point	Circuit 1	Power-L
			Dual Point	Circuit 2	PE2
		Non-Fused Disconnect Option	Dual Point	Circuit 1	Power-L
	380, 460, 575	Standard (Terminal Block)	Single Point	Circuit 1	PE1
			Dual Point	Circuit 1	PE1
			Dual Point	Circuit 2	PE2
		Non-Fused Disconnect	Single Point	Circuit 1	PE1
			Dual Point	Circuit 1	PE1
			Dual Point	Circuit 2	PE2

\*Dual point connection is not available when non-fused disconnect option is selected.  
†Single point connection not available.

Fig. 48 — Control and Power Wiring Schematic, 30RB060-390

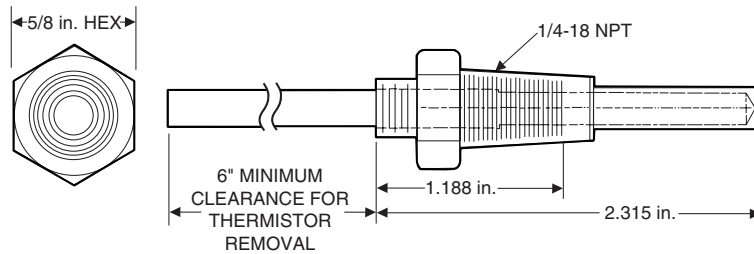


**NON-FUSED DISCONNECT**

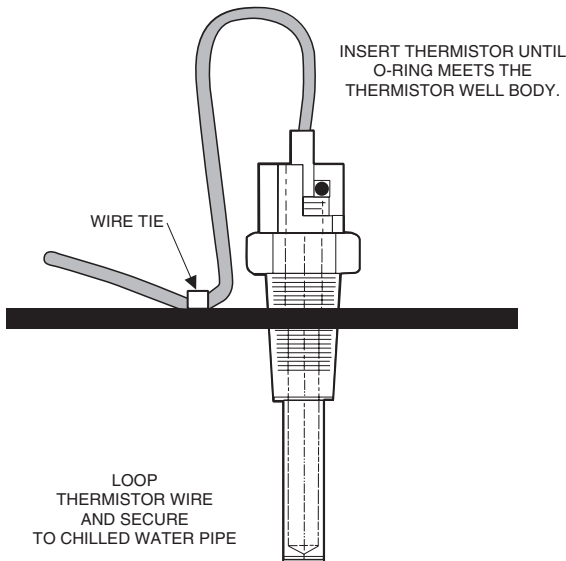


\*Field-supplied.

**Fig. 48 — Control and Power Wiring Schematic, 30RB060-390 (cont)**



**Fig. 49 — Dual Leaving Water Thermistor Well (Part No. 00PPG00008100A)**



**Fig. 50 — Dual Leaving Water Thermistor (Part No. 00PPG00008105A)**

**CARRIER COMFORT NETWORK® COMMUNICATION BUS WIRING** — The communication bus wiring is a shielded, 3 conductor cable with drain wire and is field supplied and installed in the field.

The system elements are connected to the communication bus in a daisy chain arrangement. The positive pin of each system element communication connector must be wired to the positive pins of the system elements on either side of it. This is also required for the negative and signal ground pins of each system element. Wiring connections for CCN should be made at TB (terminal block) 3. Consult the CCN Contractor's Manual for further information. See Fig. 51.

**NOTE:** Conductors and drain wire must be 20 AWG (American Wire Gage) minimum stranded, tinned copper. Individual conductors must be insulated with PVC, PVC/nylon, vinyl, Teflon, or polyethylene. An aluminum/polyester 100% foil shield and an outer jacket of PVC, PVC/nylon, chrome vinyl, or Teflon with a minimum operating temperature range of -4 F (-20 C) to 140 F (60 C) is required. Refer to Table 13 for a list of manufacturers that produce CCN bus wiring that meets these requirements.

**Table 13 — CCN Communication Bus Wiring**

MANUFACTURER	PART NUMBER	
	Regular Wiring	Plenum Wiring
Alpha	1895	—
American	A21451	A48301
Belden	8205	884421
Columbia	D6451	—
Manhattan	M13402	M64430
Quabik	6130	—

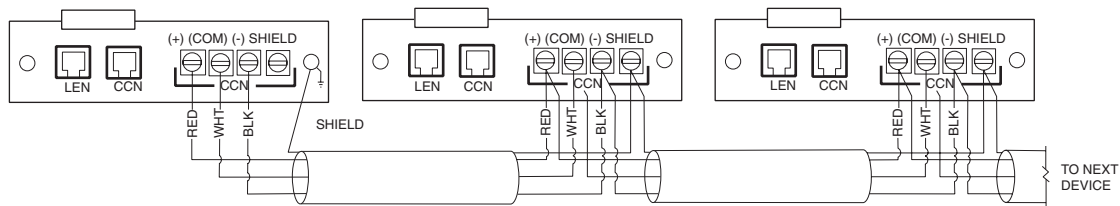
It is important when connecting to a CCN communication bus that a color coding scheme be used for the entire network to simplify the installation. It is recommended that red be used for the signal positive, black for the signal negative, and white for the signal ground. Use a similar scheme for cables containing different colored wires. At each system element, the shields of its communication bus cables must be tied together. If the communication bus is entirely within one building, the resulting continuous shield must be connected to a ground at one point only. If the communication bus cable exits from one building and enters another, the shields must be connected to grounds at the lightning suppressor in each building where the cable enters or exits the building (one point per building only).

To connect the unit to the network:

1. Turn off power to the control box.
2. Cut the CCN wire and strip the ends of the red (+), white (ground), and black (-) conductors. Substitute appropriate colors for different colored cables.
3. Connect the red wire to (+) terminal on TB3 of the plug, the white wire to COM terminal, and the black wire to the (-) terminal.
4. The RJ14 CCN connector on TB3 can also be used, but is only intended for temporary connection (for example, a laptop computer running Service Tool).

**IMPORTANT:** A shorted CCN bus cable will prevent some routines from running and may prevent the unit from starting. If abnormal conditions occur, disconnect the machine from the CCN Network. If conditions return to normal, check the CCN connector and cable. Run new cable if necessary. A short in one section of the bus can cause problems with all system elements on the bus.

**NON-CCN COMMUNICATION WIRING** — The 30RB units offer several non-CCN translators. Refer to the separate installation instructions for additional wiring steps.



**LEGEND**  
**CCN** — Carrier Comfort Network®  
**LEN** — Local Equipment Network

**Fig. 51 — TB-3 — CCN Wiring**

**Step 6 — Install Accessories** — A number of accessories are available to provide the following optional features (for details, refer to the Controls, Start-Up, Operation, Service and Troubleshooting guide).

Energy Management Module is used for any of the following types of temperature reset, demand limit and ice features:

- 4 to 20 mA inputs for cooling set point reset and capacity limit (requires field-supplied 4 to 20 mA generator)
- 0 to 10 v output for percentage total capacity running
- 24 v discrete outputs for shutdown and running relays
- 10k space temperature input
- Discrete inputs for occupancy override, demand limit switch 2 (step 1 demand limit is wired to the base board, requires field-supplied dry contacts), remote lockout switch and ice done switch (requires field-supplied dry contacts)

**NAVIGATOR™ DISPLAY** — Provides hand-held, mobile capability using easy to read 4-line display. Keypad function is the same as the scrolling marquee display. The Navigator display features a mounting magnet for ‘hands free’ service of components.

**REMOTE ENHANCED DISPLAY** — For applications where remote monitoring of the equipment is required; the Remote Enhanced Display provides an indoor display, capable of monitoring any equipment on the Carrier Comfort Network® (CCN) bus. A CCN bus is needed.

**LOW AMBIENT TEMPERATURE OPERATION** — If outdoor ambient operating temperatures below 32 F (0° C) are expected, refer to separate installation instructions for low ambient temperature operation using the low ambient temperature head pressure control accessory.

**MINIMUM LOAD ACCESSORY** — If minimum load accessory is required, contact your local Carrier representative for more details. For installation details, refer to separate installation instructions supplied with the accessory package.

**UNIT SECURITY/PROTECTION ACCESSORIES** — For applications with unique security and/or protection requirements, several options are available for unit protection. Compressor enclosures, security grilles and hail guards are available. Contact your local Carrier representative for more details. For installation details, refer to separate installation instructions supplied with the accessory package.

**COMMUNICATION ACCESSORIES** — A number of communication options are available to meet any requirement. Contact your local Carrier representative for more details. For installation details, refer to separate installation instructions supplied with the accessory package.

**SERVICE OPTIONS** — Two additional accessories are offered to aid in servicing 30RB units. A ground fault convenience outlet (GFI-CO), a remote service port, is a weather-proof enclosure with a communication port to plug-in the Navigator device, are available. Contact your local Carrier representative

for more details. For installation details, refer to separate installation instructions supplied with the accessory package.

**Step 7 — Refrigerant Circuit**

**LEAK TESTING** — Units are shipped with complete operating charge of R-410A (see Tables 3A-4B) and should be under sufficient pressure to conduct a leak test.

**⚠ CAUTION**

This system uses Puron® R-410a refrigerant, which has higher pressures than R-22 and other refrigerants. No other refrigerant can be used in this system. Failure to use gage set, hoses, and recovery systems designed to handle Puron R-410a refrigerant may result in equipment damage or personal injury. If unsure about equipment, consult the equipment manufacturer.

Perform a leak test to ensure that leaks have not developed during unit shipment. Dehydration of the system is not required unless the entire refrigerant charge has been lost. Compressor oil equalization line fittings use Roto-lok fittings. If a leak is detected at these fittings, tighten fitting 107 ft-lb (145 Nm). If leak persists, open system and inspect the gasket surface for foreign material or damage. Do not reuse gaskets. Repair any leak found using good refrigeration practice.

**DEHYDRATION** — Refer to Carrier Standard Service Techniques Manual, Chapter 1, Refrigerants, Sections 6 and 7 for details. Do not use compressor to evacuate system.

**REFRIGERANT CHARGE** (Refer to Tables 3A-4B) — Immediately ahead of filter drier in each circuit is a factory-installed liquid line service valve. Each valve has a 1/4-in. Schrader connection for charging liquid refrigerant. Refer to Controls, Start-Up, Operation, Service and Troubleshooting Guide for more information.

**⚠ CAUTION**

When charging, circulate water through the cooler at all times to prevent freezing. Freezing damage is considered abuse and may void the Carrier warranty.

**⚠ CAUTION**

**DO NOT OVERCHARGE** system. Overcharging results in higher discharge pressure possible compressor damage, and higher power consumption.

**⚠ CAUTION**

Refrigerant charge must be removed slowly to prevent loss of compressor oil that could result in compressor failure.

