

NOTE: REFERENCE SHEET A4.21 FOR BATHROOM ACCESSORY LEGEND AND INSTALLATION HEIGHTS.

1 INTERIOR ELEVATIONS FOR BATHROOM IN MANAGER'S APARTMENT UNIT

REFERENCED FROM: SCALE: 3/8"=1'-0"

4 PLAN OF BATHROOM IN MANAGER'S APARTMENT UNIT

REFERENCED FROM: SCALE: 3/8"=1'-0"

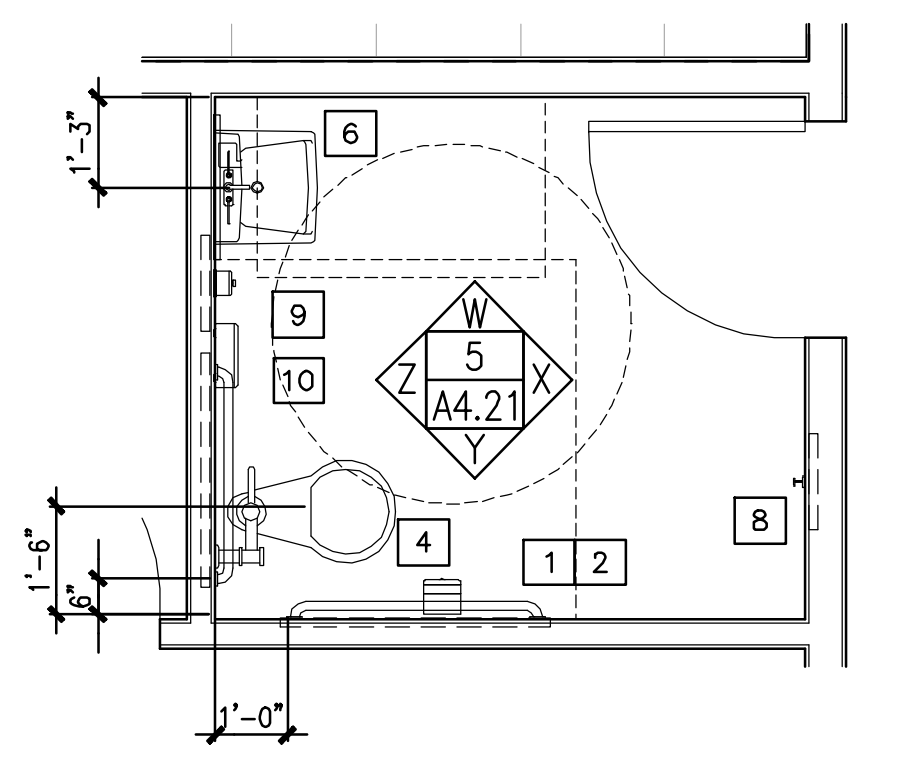
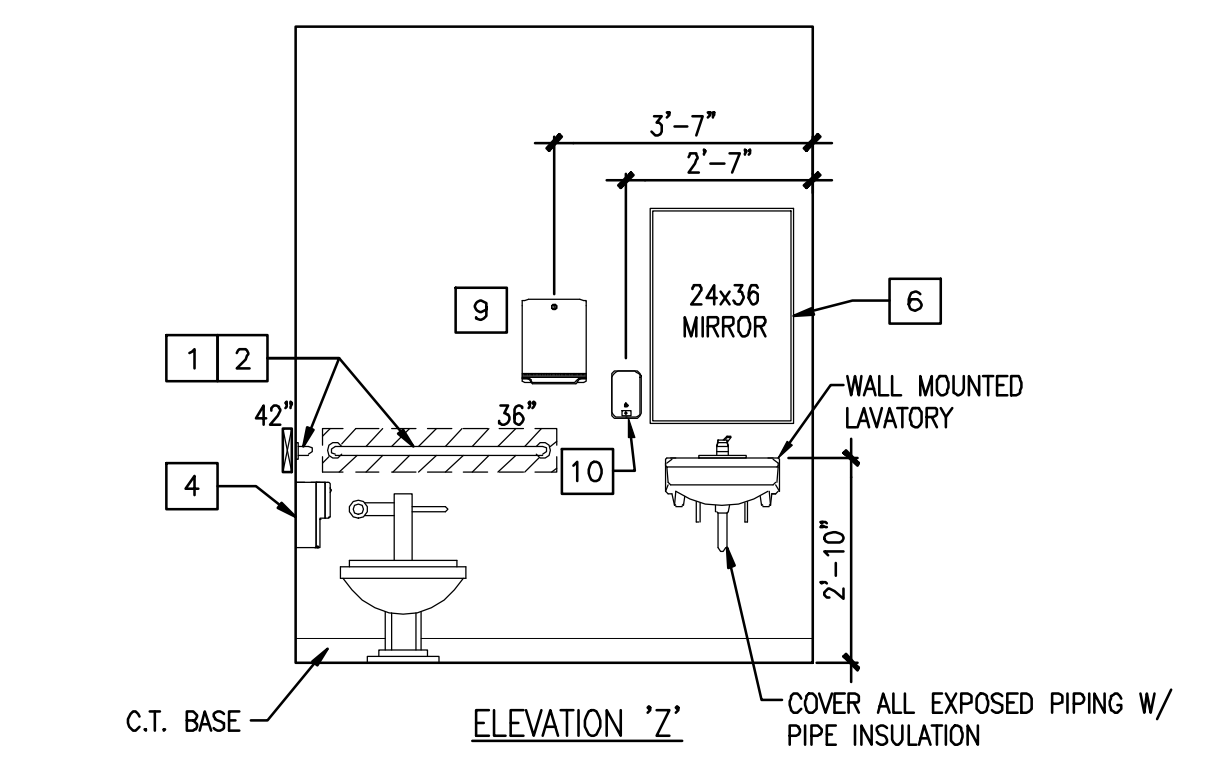
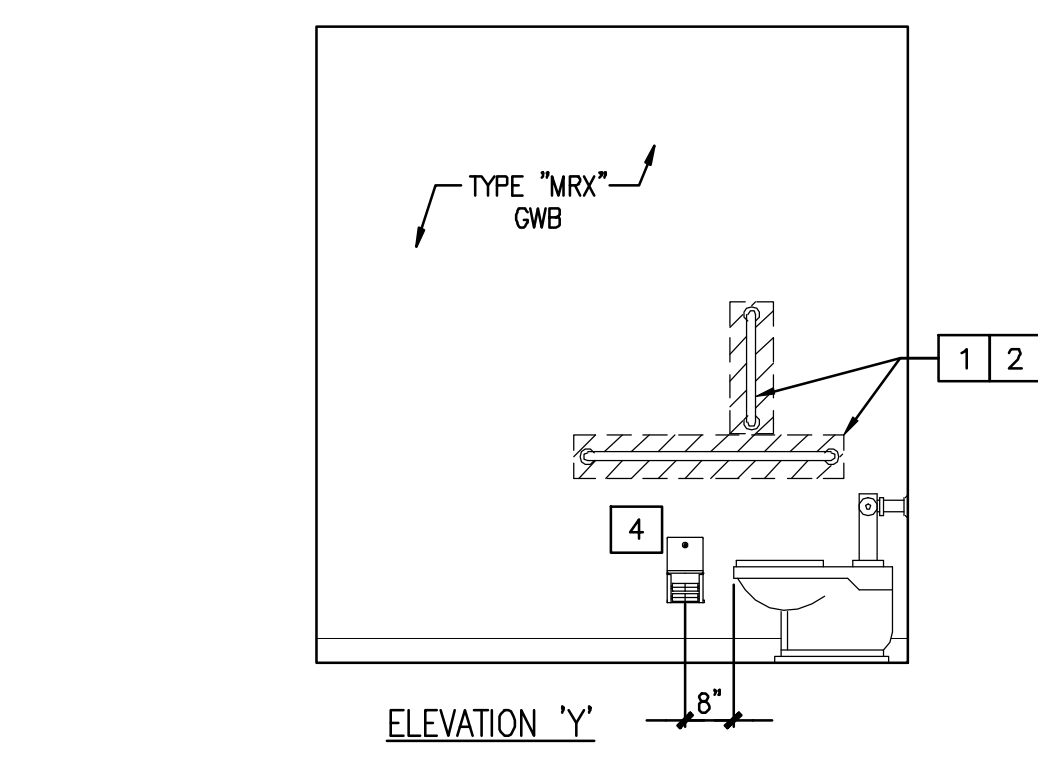
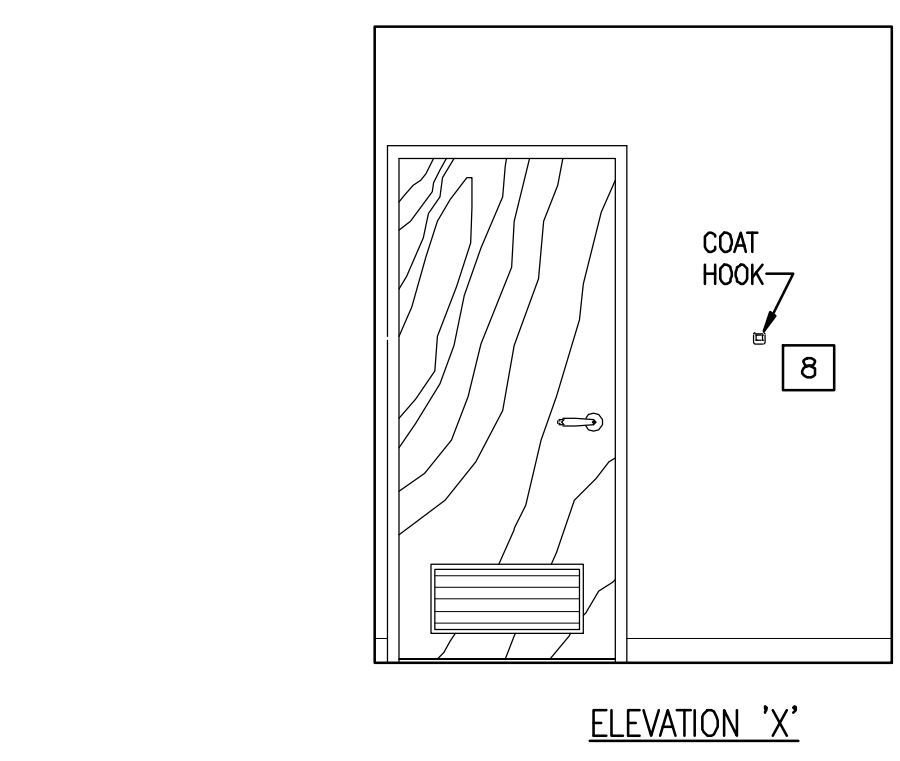
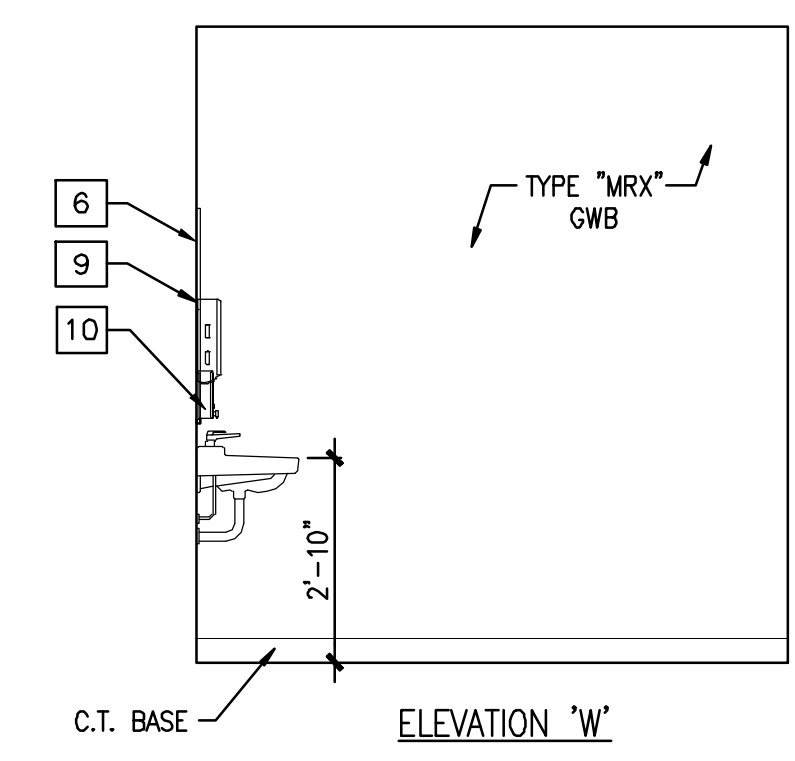

NOTE: REFERENCE SHEET A4.21 FOR BATHROOM ACCESSORY LEGEND AND INSTALLATION HEIGHTS.

5 INTERIOR ELEVATIONS FOR PUBLIC BATHROOM

REFERENCED FROM: SCALE: 3/8"=1'-0"

8 PLAN OF PUBLIC BATHROOM

REFERENCED FROM: SCALE: 3/8"=1'-0"

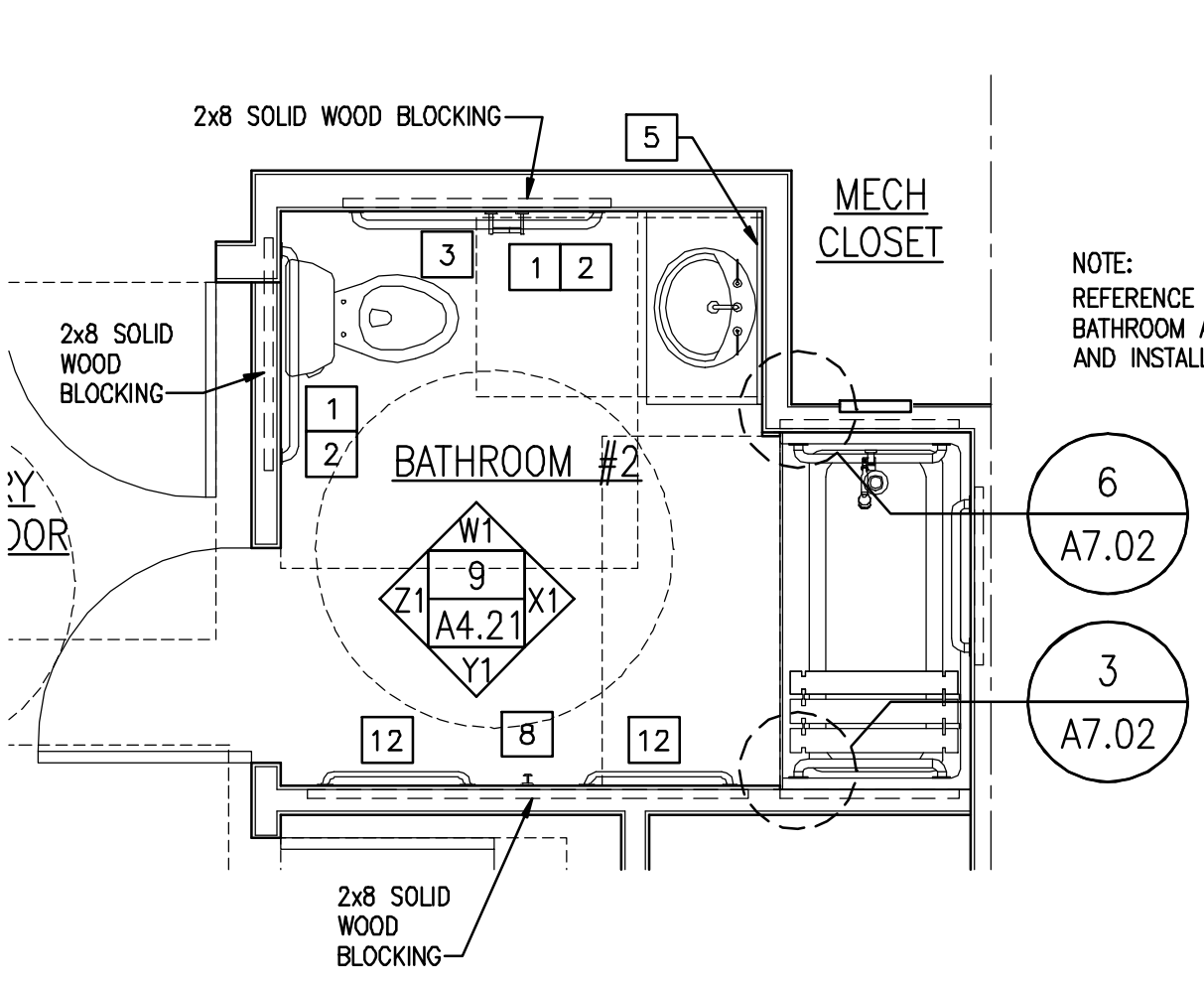
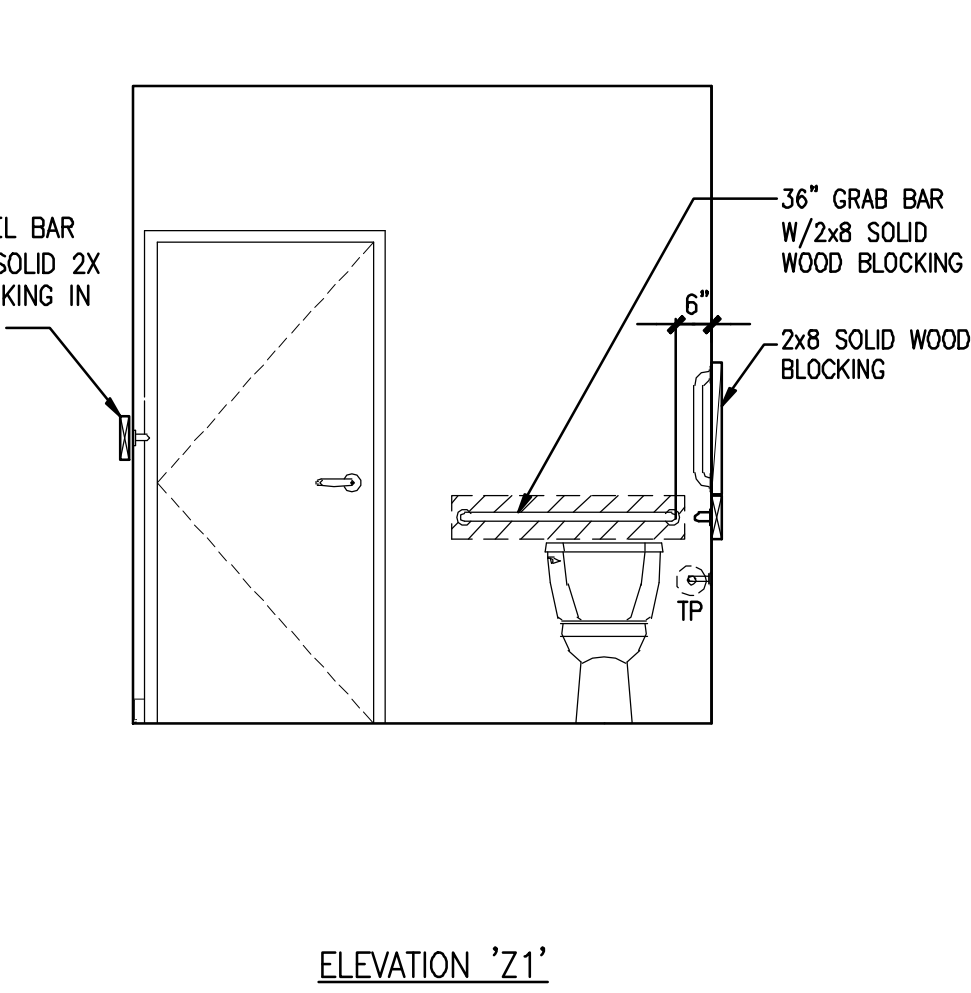
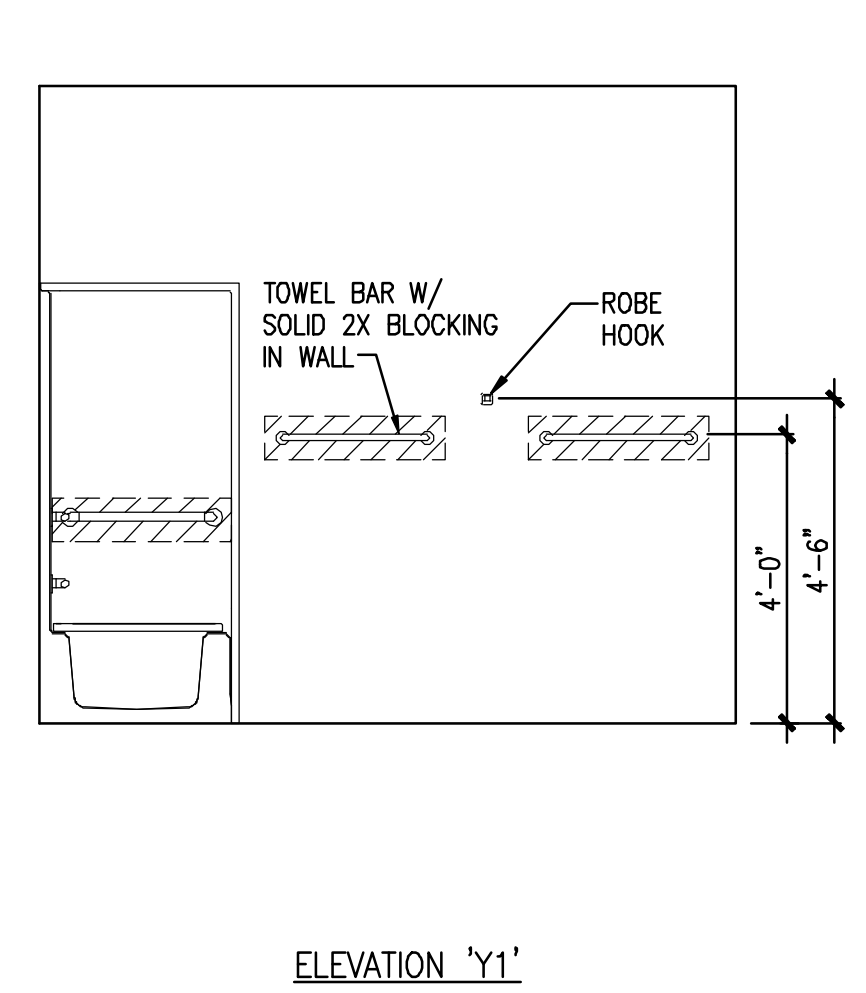
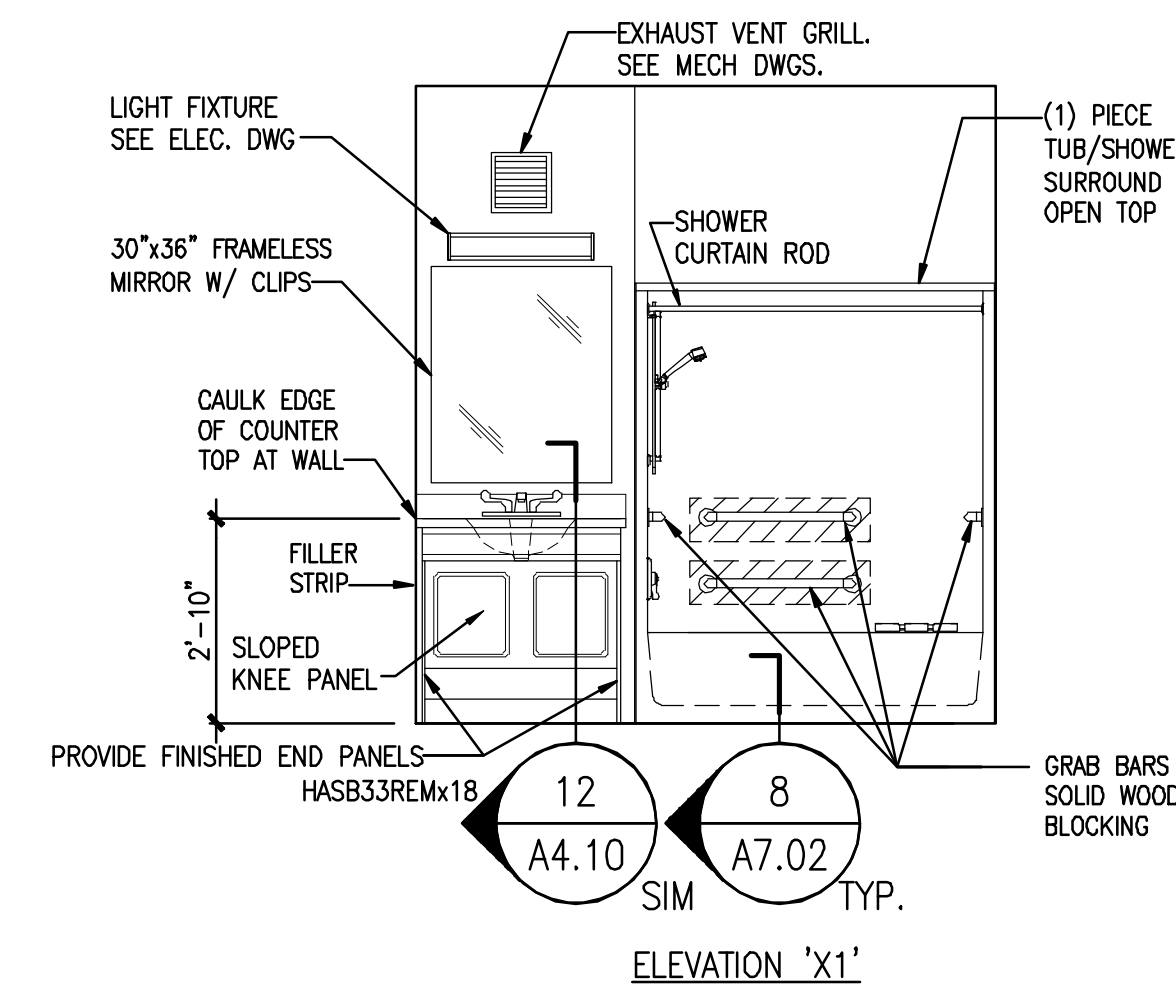
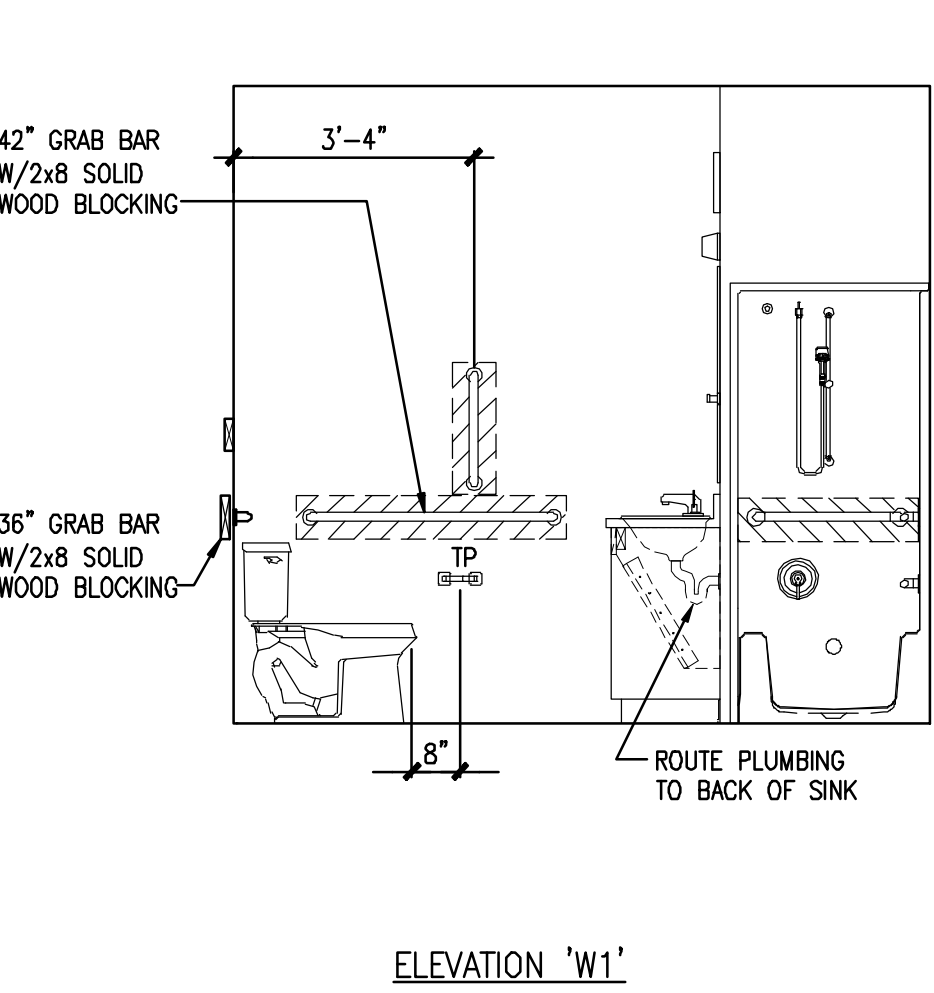

NOTE: REFERENCE SHEET A4.21 FOR BATHROOM ACCESSORY LEGEND AND INSTALLATION HEIGHTS.

9 INTERIOR ELEVATIONS FOR BATHROOM #2 IN UNITS #1 AND #4

REFERENCED FROM: SCALE: 3/8"=1'-0"

12 PLAN OF BATHROOM #2 IN UNITS #1 AND #4

REFERENCED FROM: SCALE: 3/8"=1'-0"

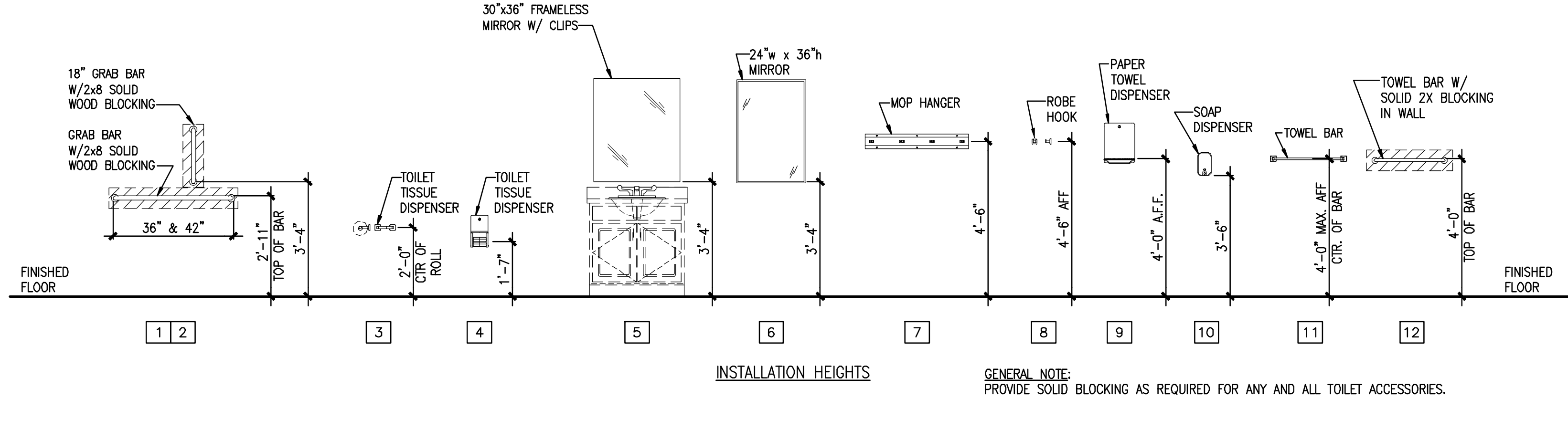
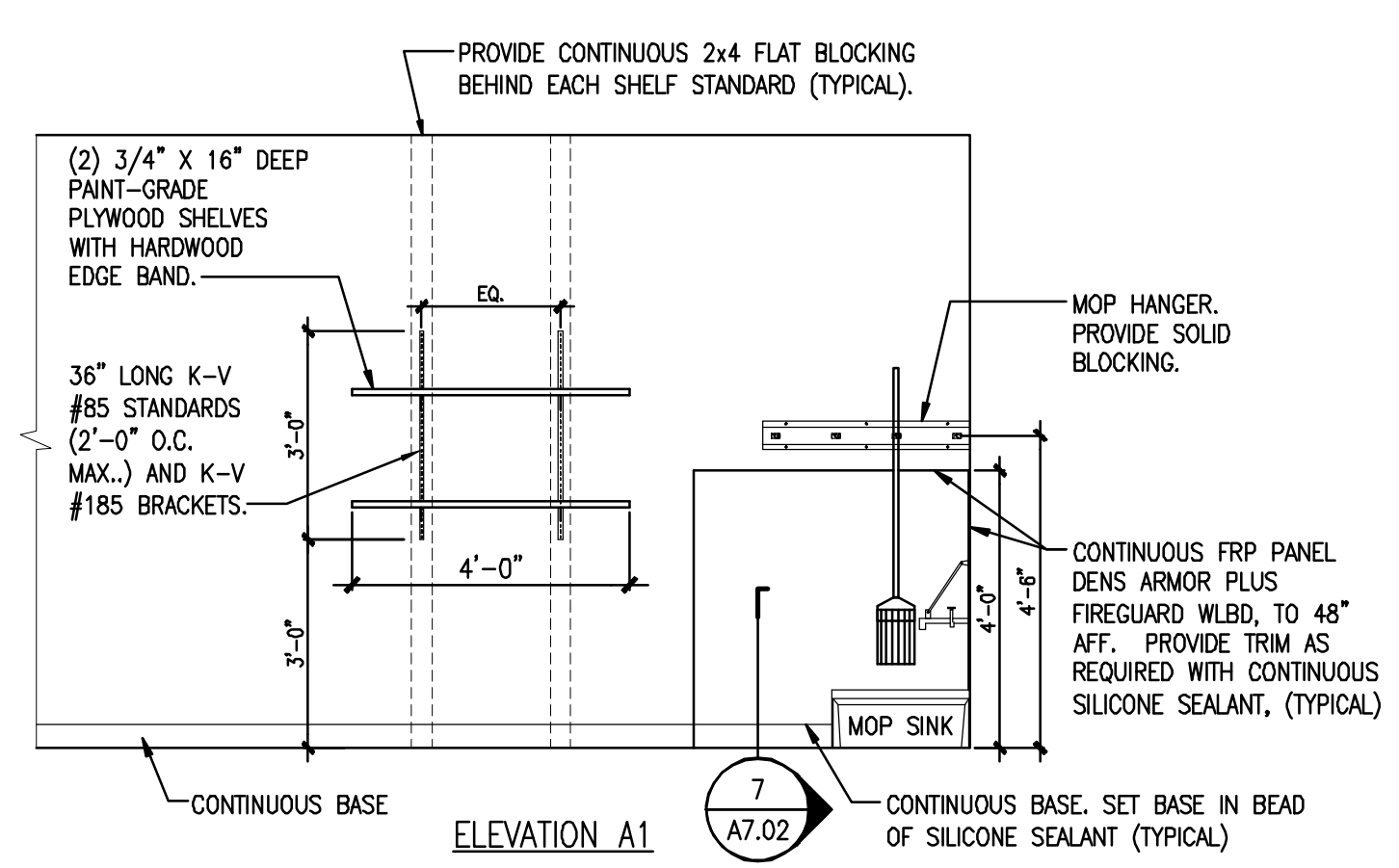

- 1 GRAB BARS, STAINLESS STEEL W/ CONCEALED MOUNTING:
- 2 GRAB BAR ANCHORS:
- 3 TOILET TISSUE DISPENSER, SINGLE-ROLL, SURFACE MOUNTED:
- 4 TOILET TISSUE DISPENSER, MULTI-ROLL, SURFACE MOUNTED:
- 5 MIRROR, FRAMELESS W/ CLIPS, 30x36 INCHES
- 6 MIRROR WITH STAINLESS STEEL CHANNEL FRAME:
- 7 MOP HOLDER:
- 8 ROBE HOOK, SINGLE:
- 9 PAPER TOWEL DISPENSER:
- 10 SOAP DISPENSER, SURFACE MOUNTED:
- 11 24\"/>

13 INTERIOR ELEVATIONS FOR JANITOR CLOSET

REFERENCED FROM: SCALE: 3/8"=1'-0"

14 BATHROOM ACCESSORY LEGEND AND INSTALLATION HEIGHTS

REFERENCED FROM: SCALE: 3/8"=1'-0"

CWS
CWS Architects
 Architecture
 Space Planning
 Value Design
 434 Cumberland Avenue
 Portland, ME 04101
 Phone: (207) 774-4441
 Fax: (207) 774-4016
 www.CWSarch.com

BENEDICT & WALTER
 REGISTERED ARCHITECT
 NO. 1947
 STATE OF MAINE

Owner:
SOUTHERN MAINE STUDENT HOUSING LLC
 247 COMMERCIAL STREET
 ROCKPORT, MAINE 04856
 TEL: (207) 236-4067

Contractor:
PIZZAGALLI CONSTRUCTION
 131 PRESUMPSCOT STREET
 PORTLAND, ME 04103
 TEL: (207) 874-2323
 FAX: (207) 874-2727

BAYSIDE VILLAGE - A STUDENT HOUSING COMPLEX
 132 MARGINAL WAY
 PORTLAND, MAINE

Project No: 2006-432/BVP

Drawing Title:
INTERIOR ELEVATIONS UNIT-BATHROOMS AND LEGEND

Scale: AS NOTED
 Date: SEPTEMBER 14, 2007

Revisions:

Drawing Number:
A4.21

ISSUED FOR CONSTRUCTION