

NOTES:

1. COMPACT GRAVEL SUBBASE, BASE COURSE TO 92% OF MAXIMUM DENSITY USING HEAVY ROLLER COMPACTION.
2. CONTRACTOR SHALL SET GRADE STAKES MARKING SUBBASE AND FINISH GRADE ELEVATIONS FOR CONSTRUCTION REFERENCE.
3. ACCESSIBLE PARKING SPACES AND ACCESS AISLES CANNOT EXCEED A SLOPE OF 1:50 IN ANY DIRECTION.

**PAVED PARKING LOT/
DRIVEWAY SECTION**

NOT TO SCALE

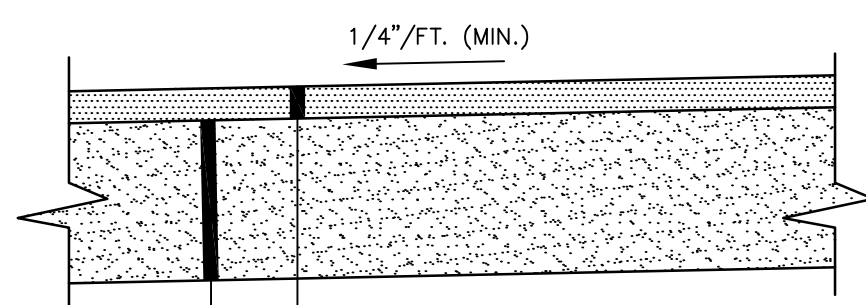

NOTE:

SIDEWALKS ON ACCESSIBLE ROUTES CANNOT EXCEED A SLOPE OF 1:20 IN DIRECTION OF TRAVEL NOR 1:50 CROSS SLOPE.

BITUMINOUS SIDEWALK

NOT TO SCALE

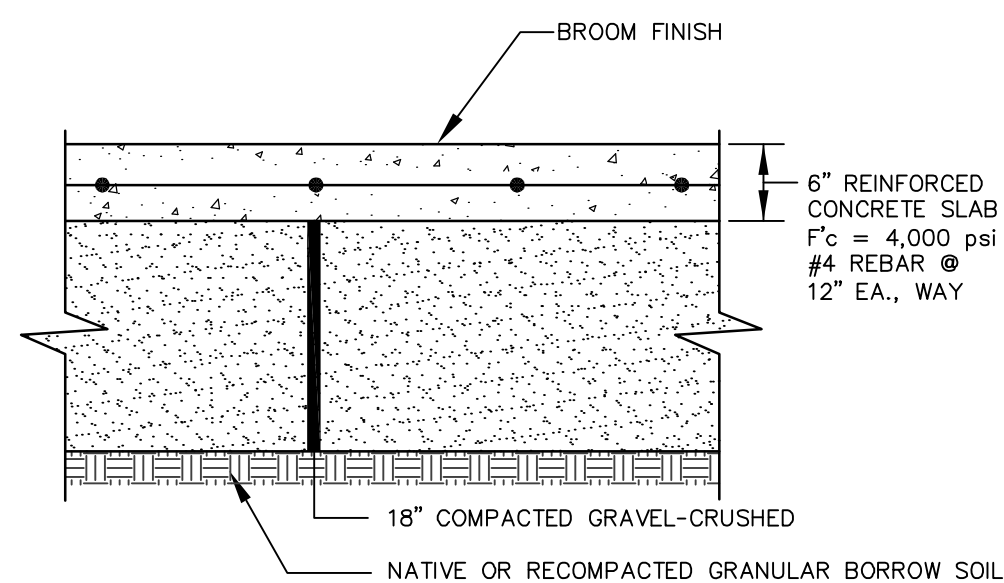

NOTES:

1. PROVIDE CONTRACTION CONTROL JOINTS EVERY 6' IN EACH DIRECTION.
2. SIDEWALKS ON ACCESSIBLE ROUTES CANNOT EXCEED A SLOPE OF 1:20 IN DIRECTION OF TRAVEL NOR 1:50 CROSS SLOPE.

6" CONCRETE PAVING

NOT TO SCALE

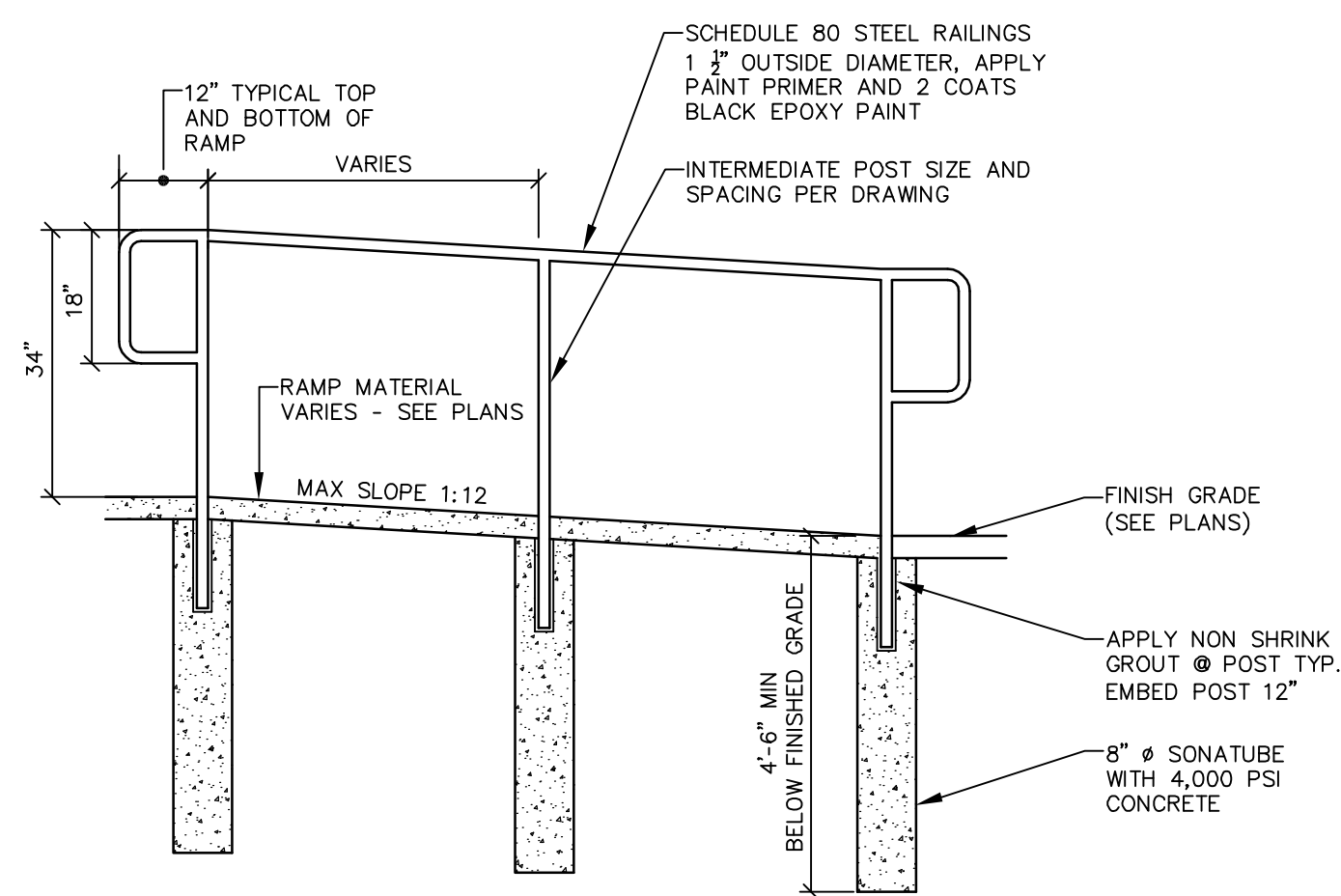

NOTES:

1. PROVIDE SHOP DRAWINGS INCLUDING MATERIALS, FABRICATION DETAILS, LAYOUT AND FINISH OF HANDRAILS FOR ENGINEER'S APPROVAL.
2. ENDS OF HANDRAIL SHALL BE EITHER ROUNDED OR RETURNED SMOOTHLY TO GROUND.
3. ALL HAND RAILS SHALL MEET APPLICABLE ADA STANDARDS.
4. ALL LANDINGS SHALL HAVE A MAXIMUM CROSS SLOPE OF 2%. ALL RAMP SLOPES SHALL NOT EXCEED 1:12.
5. SET RAIL TO BUTT AGAINST EACH EDGE OF SIDEWALK BOTH SIDES OF RAMP.

RAMP HANDRAIL DETAIL

NOT TO SCALE

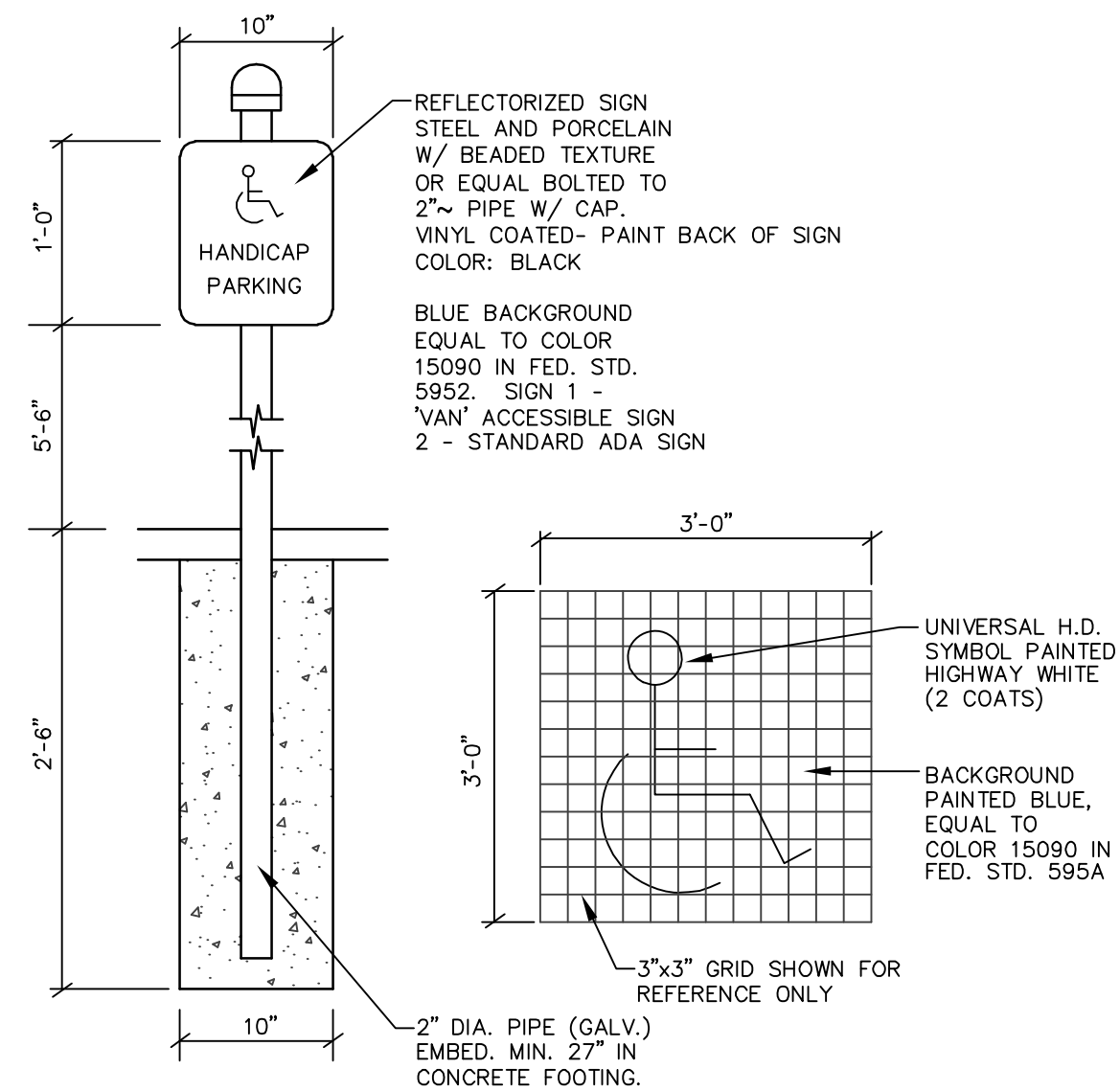

HANDICAP SIGNS/SYMBOLS

NOT TO SCALE

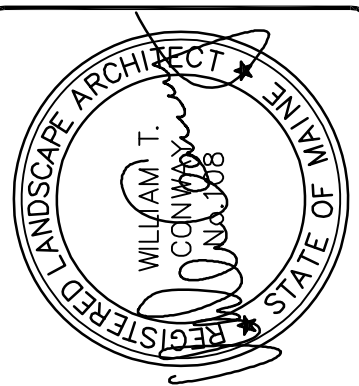

DESIGNED	CHECKED
WTC	WTC
D WTC 11-22-17	100% CONSTRUCTION DOCUMENTS
C WTC 09-11-17	90% MAINE HOUSING SUBMISSION
B WTC 03-30-17	50% MAINE HOUSING SUBMISSION
A WTC 09-28-16	ISSUED FOR REVIEW
REV. BY:	DATE:
STATUS:	

THIS PLAN SHALL NOT BE MODIFIED WITHOUT WRITTEN PERMISSION FROM SEBAGO TECHNIQS, INC. ANY ALTERATIONS AUTHORIZED OR OTHERWISE, SHALL BE AT THE USER'S SOLE RISK AND WITHOUT LIABILITY TO SEBAGO TECHNIQS, INC.

SEBAGO
TECHNICS
WWW.SEAGOTECHNIQS.COM
79 John Roberts Rd., Suite B
South Portland, ME 04106
Tel. 207-200-2100 Tel. 207-783-5656

SITE DETAILS
OF: **NORTHFIELD GREEN COMMUNITY**
ALLEN AVENUE
PORTLAND, MAINE
FOR: **CWS ARCHITECTS**
434 CUMBERLAND AVENUE
PORTLAND, MAINE 04101

PROJECT NO.	SCALE
16173	AS SHOWN