

DISPLAY THIS CARD ON PRINCIPAL FRONTAGE OF WORK



CITY OF PORTLAND

BUILDING PERMIT

This is to certify that DEVELOPMENT COMPANY LLC located At 22 YALE ST

Job ID: 2011-05-1144-UI

CBL: 436- A-008-001

has permission to Install a Prestidge Boiler

provided that the person or persons, firm or corporation accepting this permit shall comply with all of the provisions of the Statutes of Maine and of the Ordinances of the City of Portland regulating the construction, maintenance and use of the buildings and structures, and of the application on file in the department.

Notification of inspection and written permission procured before this building or part thereof is lathed or otherwise closed-in. 48 HOUR NOTICE IS REQUIRED.

A final inspection must be completed by owner before this building or part thereof is occupied. If a certificate of occupancy is required, it must be

Fire Prevention Officer

Code Enforcement Officer / Plan Reviewer

**THIS CARD MUST BE POSTED ON THE STREET SIDE OF THE PROPERTY
PENALTY FOR REMOVING THIS CARD**



Certificate of Occupancy



CITY OF PORTLAND, MAINE

Department of Planning and Urban Development

Building Inspections Division

Location: 22 YALE ST

CBL: 436- A-008-001

Issued to: MJ, DEVELOPMENT COMPANY LLC

Date Issued: 7/9/2012

This is to certify that the building, premises, or part thereof, at the above location, built-altered-changed as to use under Building Permit No. 2011-05-1144-UI, has had a final inspection, has been found to conform substantially to the requirements of the Building Code and the Land Use Code of the City of Portland, and is hereby approved for occupancy or use, limited or otherwise, as indicated below.

PORTION OF BUILDING OR PREMISES

ENTIRE

APPROVED OCCUPANCY

USE GROUP R-3
SINGLE FAMILY DWELLING
UNFINISHED BASEMENT
TYPE 5-B
IRC 2003

Approved:

7-9-12

(Date)

Inspector

Inspections Division Director

Notice: This certificate identifies the legal use of the building or premises, and ought to be transferred from owner to owner upon the sale of the property.

BUILDING PERMIT INSPECTION PROCEDURES

Please call 874-8703 or 874-8693 (ONLY)

or email: buildinginspections@portlandmaine.gov

With the issuance of this permit, the owner, builder or their designee is required to provide adequate notice to the city of Portland Inspections Services for the following inspections. Appointments must be requested 48 to 72 hours in advance of the required inspection. The inspection date will need to be confirmed by this office.

- **Please read the conditions of approval that is attached to this permit!! Contact this office if you have any questions.**
- **Permits expire in 6 months. If the project is not started or ceases for 6 months.**
- **If the inspection requirements are not followed as stated below additional fees may be incurred due to the issuance of a "Stop Work Order" and subsequent release to continuc.**

The project cannot move to the next phase prior to the required inspection and approval to continue, REGARDLESS OF THE NOTICE OF CIRCUMSTANCES.

IF THE PERMIT REQUIRES A CERTIFICATE OF OCCUPANCY, IT MUST BE PAID FOR AND ISSUED TO THE OWNER OR DESIGNEE BEFORE THE SPACE MAY BE OCCUPIED.

City of Portland, Maine - Building or Use Permit Application

389 Congress Street, 04101 Tel: (207) 874-8703, FAX: (207) 8716

Job No: 2011-05-1144-UI 2012-40600-HVAC	Date Applied: 2/7/2012	CBL: 436- A-008-001	
Location of Construction: 22 YALE ST	Owner Name: MJ DEVELOPMENT COMPANY LLC	Owner Address: 31 OLD CAMPUS DR PORTLAND, ME 04103	Phone:
Business Name:	Contractor Name: Jim Jackson	Contractor Address: 95 Settler Rd., South Portland, ME 04106	Phone: 207-831-1810
Lessee/Buyer's Name:	Phone:	Permit Type: HVAC	Zone: R-3
Past Use: Single family	Proposed Use: Same Single family – install boiler in basement	Cost of Work: 6000.00	CEO District:
		Fire Dept: Approved Denied N/A	Inspection: 123 Use Group: Type: Signature:
Proposed Project Description: install boiler		Pedestrian Activities District (P.A.D.)	
Permit Taken By:	Zoning Approval		

<p>1. This permit application does not preclude the Applicant(s) from meeting applicable State and Federal Rules.</p> <p>2. Building Permits do not include plumbing, septic or electrical work.</p> <p>3. Building permits are void if work is not started within six (6) months of the date of issuance. False informatin may invalidate a building permit and stop all work.</p>	<p>Special Zone or Reviews</p> <p><input type="checkbox"/> Shoreland</p> <p><input type="checkbox"/> Wetlands</p> <p><input type="checkbox"/> Flood Zone</p> <p><input type="checkbox"/> Subdivision</p> <p><input type="checkbox"/> Site Plan</p> <p>___ Maj ___ Min ___ MM</p> <p>Date: OK 2/7/12 ABM</p>	<p>Zoning Appeal</p> <p><input type="checkbox"/> Variance</p> <p><input type="checkbox"/> Miscellaneous</p> <p><input type="checkbox"/> Conditional Use</p> <p><input type="checkbox"/> Interpretation</p> <p><input type="checkbox"/> Approved</p> <p><input type="checkbox"/> Denied</p> <p>Date:</p>	<p>Historic Preservation</p> <p><input checked="" type="checkbox"/> Not in Dist or Landmark</p> <p><input type="checkbox"/> Does not Require Review</p> <p><input type="checkbox"/> Requires Review</p> <p><input type="checkbox"/> Approved</p> <p><input type="checkbox"/> Approved w/Conditions</p> <p><input type="checkbox"/> Denied</p> <p>Date: ABM</p>
	CERTIFICATION		

I hereby certify that I am the owner of record of the named property, or that the proposed work is authorized by the owner of record and that I have been authorized by the owner to make this application as his authorized agent and I agree to conform to all applicable laws of this jurisdiction. In addition, if a permit for work described in the appication is issued, I certify that the code official's authorized representative shall have the authority to enter all areas covered by such permit at any reasonable hour to enforce the provision of the code(s) applicable to such permit.

SIGNATURE OF APPLICANT ADDRESS DATE PHONE

RESPONSIBLE PERSON IN CHARGE OF WORK, TITLE DATE PHONE

R-3



FILL IN AND SIGN WITH INK

APPLICATION FOR PERMIT HEATING OR POWER EQUIPMENT

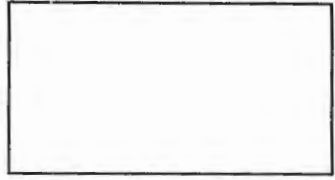

original 2011-05-1144
child - 2012-4-0600

To the INSPECTOR OF BUILDINGS, PORTLAND, ME.

The undersigned hereby applies for a permit to install the following heating, cooking or power equipment in accordance with the Laws of Maine, the Building Code of the City of Portland, and the following specifications:

Location / CBL Portland 436-A-8 Use of Building single family Date 7-1-11
 Name and address of owner of appliance Jim MacCormack Lt 3 York St (22 York St)
 Installer's name and address Jim Jackson 30 Bellon Rd Portland Me
95 Settler Rd Telephone 831-1810
SP 04106

Location of appliance:
 Basement Floor
 Attic Roof

Type of Fuel:
 Gas Oil Solid

Appliance Name: Prestidge
 U.L. Approved Yes No

Will appliance be installed in accordance with the manufacture's installation instructions? Yes No

IF NO Explain: _____

The Type of License of Installer:
 Master Plumber # 2731
 Solid Fuel # _____
 Oil # _____
 Gas # 8406
 Other _____

Type of Chimney:
 Masonry Lined
 Factory built _____
 Metal
 Factory Built U.L. Listing # _____
 Direct Vent
 Type PVC pipe UL# _____

Type of Fuel Tank
 Oil
 Gas N/A

Size of Tank _____

Number of Tanks _____

Distance from Tank to Center of Flame _____ feet.

Cost of Work: \$ 5,500

Permit Fee: \$ 80

RECEIVED
FEB 07 2012

Approved

Fire: _____
 Ele.: _____
 Bldg.: _____

Signature of Installer Jim Jackson

Approved with Conditions

See attached letter or requirement

Inspector's Signature _____ Date Approved _____

White - Inspection Yellow - File Pink - Applicant's Gold - Assessor's Copy

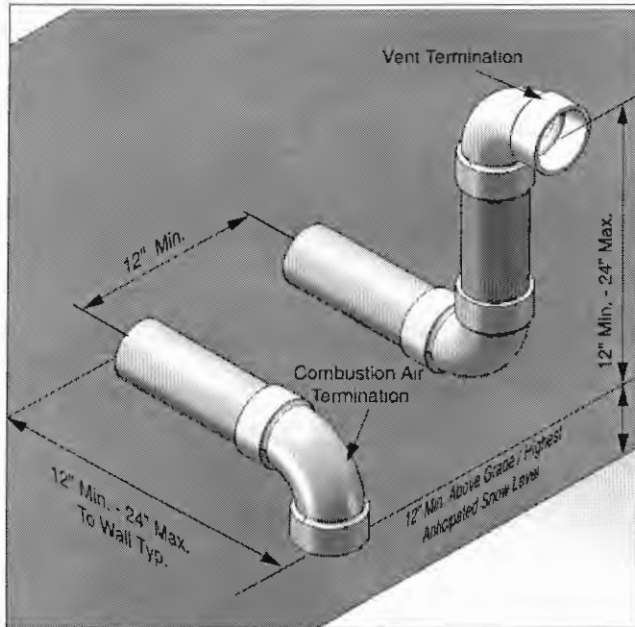

Fig. 8: Direct Vent - Sidewall Termination of Vent and Combustion Air Piping

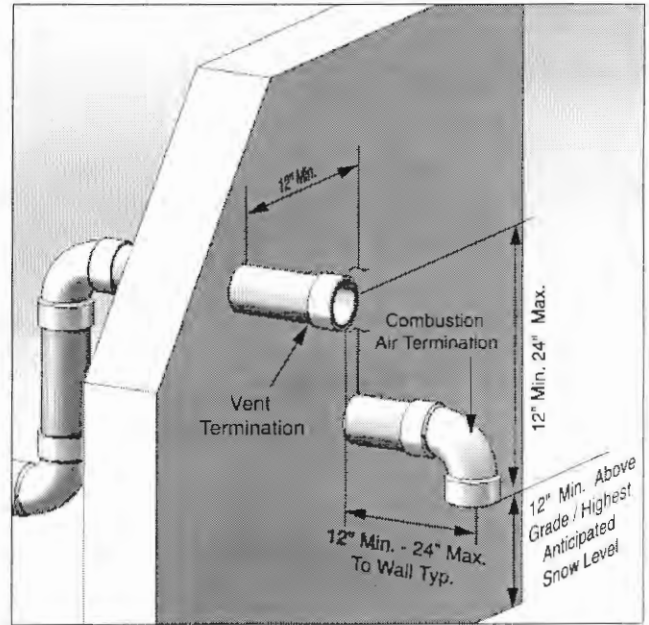

Fig. 9: Direct Vent - Alternate Sidewall Termination of Vent and Combustion Air Piping

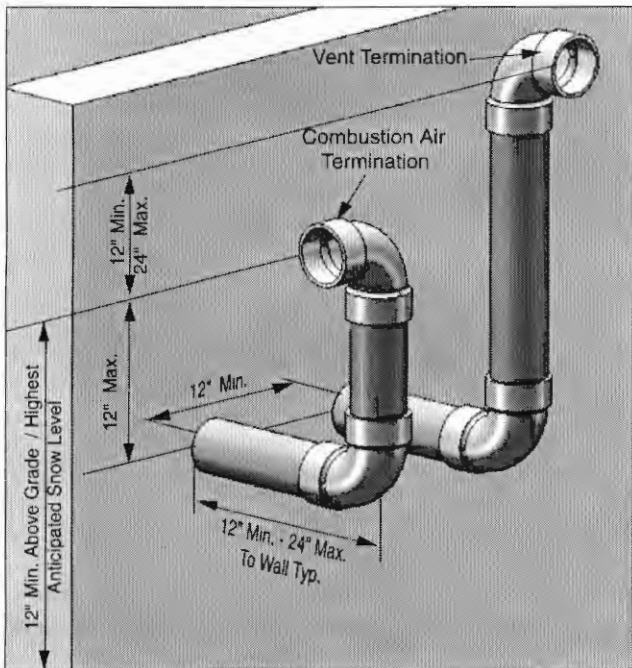

Fig. 10: Direct Vent - Sidewall Snorkel Termination of Vent and Combustion Air Piping

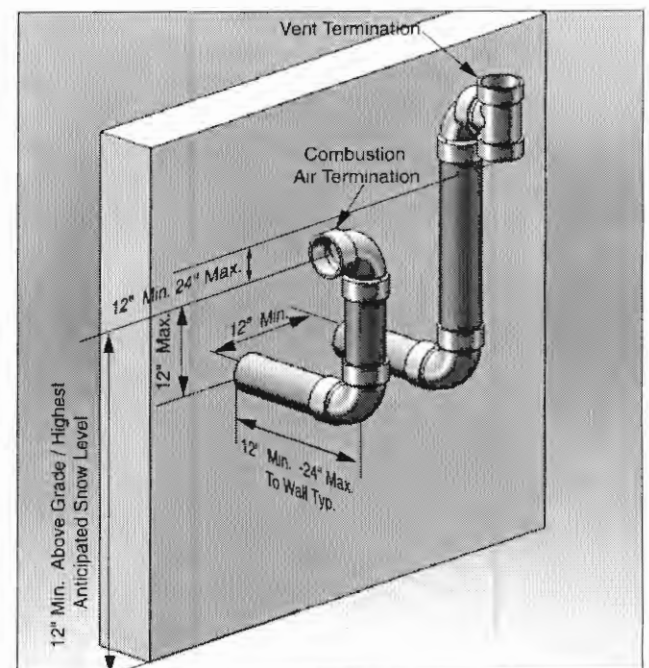

Fig. 11: Direct Vent - Sidewall Snorkel Termination of Vent and Combustion Air Piping with Tee Vent Termination

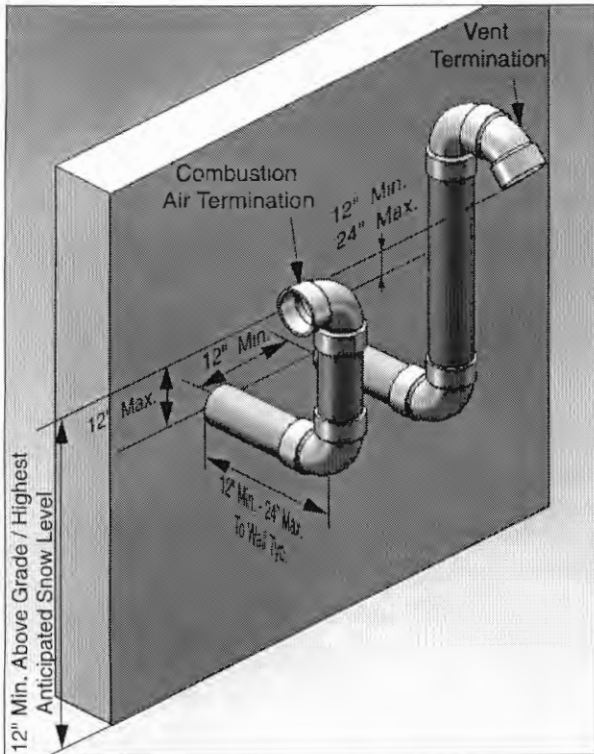

Fig. 12: Direct Vent - Sidewall Snorkel Termination of Vent and Combustion Air Piping with 45° Vent Termination

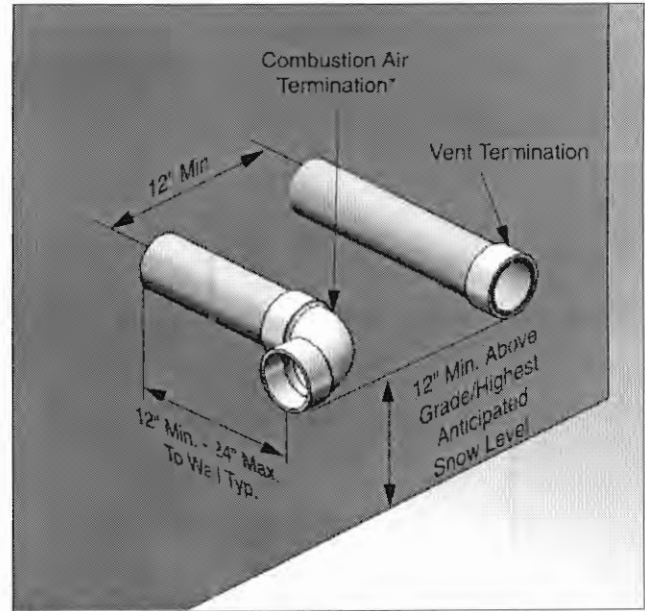

Fig. 13: Direct Vent - Sidewall Termination of Vent and Combustion Air Piping with Coupling Vent Termination

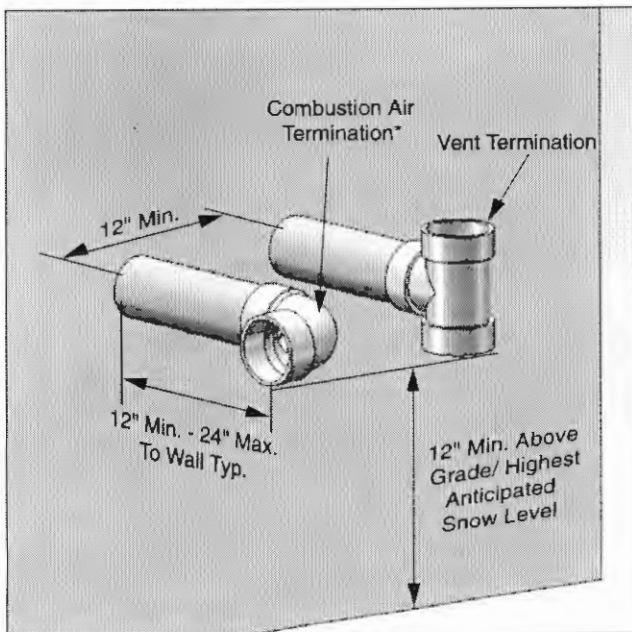

Fig. 14: Direct Vent - Sidewall Termination of Vent and Combustion Air Piping with Tee Vent Termination

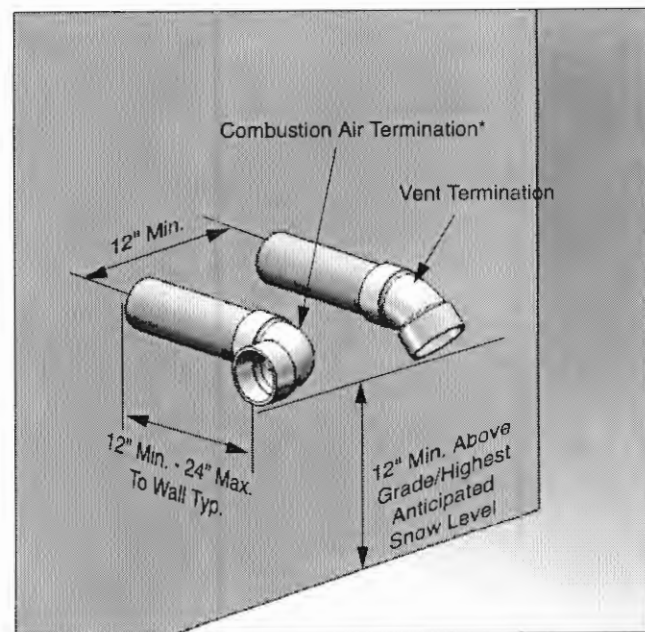

Fig. 15: Direct Vent - Sidewall Termination of Vent and Combustion Air Piping with 45° Vent Termination

NOTICE

* Combustion Air Termination should slope downward at 15° angle.

PLUMBING APPLICATION

Department of Health and Human Services
Division of Environmental Health

PROPERTY ADDRESS

Town or Plantation: Portland
Street Subdivision Lot #: Yale St Lot 3

PROPERTY OWNERS NAME

Last: Wescott First: Jim
Applicant Name: James Jackson
Mailing Address of Owner/Applicant (If Different): 30 Bolton St

PORTLAND Date Permit Issued: 7/1/11 PERMIT # 11679 TOWN COPY \$ 11170 Double Fee FEE Charged
Local Plumbing Inspector Signature: _____ L.P.I. # 1112
436-A-8

Owner/Applicant Statement

I certify that the information submitted is correct to the best of my knowledge and understand that any falsification is reason for the Local Plumbing Inspectors to deny a Permit.

Signature of Owner/Applicant: James Jackson Date: 7-1-11

Caution: Inspection Required

I have inspected the installation authorized above and found it to be in compliance with the Maine Plumbing Rules.

Local Plumbing Inspector Signature _____

Date Approved _____

PERMIT INFORMATION

This Application is for

- 1. NEW PLUMBING
- 2. RELOCATED PLUMBING

Type of Structure To Be Served:

- 1. SINGLE FAMILY DWELLING
- 2. MODULAR OR MOBILE HOME
- 3. MULTIPLE FAMILY DWELLING
- 4. OTHER - SPECIFY _____

Plumbing To Be Installed By:

- 1. MASTER PLUMBER
- 2. OIL BURNERMAN
- 3. MFG'D. HOUSING DEALER/MECHANIC
- 4. PUBLIC UTILITY EMPLOYEE
- 5. PROPERTY OWNER

LICENSE # 122311

Hook-Up & Piping Relocation Maximum of 1 Hook-Up

HOOK-UP: to public sewer in those cases where the connection is not regulated and inspected by the local Sanitary District.

OR

HOOK-UP: to an existing subsurface wastewater disposal system.

PIPING RELOCATION: of sanitary lines, drains, and piping without new fixtures.

OR

TRANSFER FEE
[\$6.00]

Number	Column 2 Type of Fixture	Number	Column 1 Type of Fixture
1	Hosebib / Sillcock	2	Bathtub (and Shower)
	Floor Drain	1	Shower (Separate)
	Urinal	3	Sink
	Drinking Fountain		Wash Basin
	Indirect Waste	3	Water Closet (Toilet)
	Water Treatment Softener, Filter, etc.	1	Clothes Washer
	Grease / Oil Separator	1	Dish Washer
	Roof Drain	1	Garbage Disposal
	Bidet	1	Laundry Tub
	Other: _____	1	Water Heater
1	Fixtures (Subtotal) Column 2	15	Fixtures (Subtotal) Column 1
			Fixtures (Subtotal) Column 2
			Total Fixtures
			Fixture Fee
			Transfer Fee
			Hook-Up & Relocation Fee
		170	Permit Fee (Total)

SEE PERMIT FEE SCHEDULE FOR CALCULATING FEE

170
110
180

RECEIVED
JUL - 1 2011
Dept. of Building Inspections
City of Portland Maine

436 A-8