

DISPLAY THIS CARD ON PRINCIPAL FRONTAGE OF WORK



# CITY OF PORTLAND BUILDING PERMIT

This is to certify that DEVELOPMENT COMPANY LLC MJ

Located At 12 YALE

Job ID: 2011-04-878-HVAC

CBL: 436 - - A - 005 - 001 - - - -

has permission to Prestidge Excellance direct vent heating system  
provided that the person or persons, firm or corporation accepting this permit shall comply with all of the provisions of the Statues of Maine and of the Ordinances of the City of Portland regulating the construction, maintenance and use of the buildings and structures, and of the application on file in the department.

Notification of inspection and written permission procured before this building or part thereof is lathed or otherwise closed-in. 48 HOUR NOTICE IS REQUIRED.

A final inspection must be completed by owner before this building or part thereof is occupied. If a certificate of occupancy is required, it must be

\_\_\_\_\_  
Fire Prevention Officer

\_\_\_\_\_  
Code Enforcement Officer / Plan Reviewer

THIS CARD MUST BE POSTED ON THE STREET SIDE OF THE PROPERTY.  
PENALTY FOR REMOVING THIS CAR

*OK to close + snow NA*

## BUILDING PERMIT INSPECTION PROCEDURES

Please call 874-8703 or 874-8693 (ONLY)

or email: [buildinginspections@portlandmaine.gov](mailto:buildinginspections@portlandmaine.gov)

With the issuance of this permit, the owner, builder or their designee is required to provide adequate notice to the city of Portland Inspections Services for the following inspections. Appointments must be requested 48 to 72 hours in advance of the required inspection. The inspection date will need to be confirmed by this office.

- **Please read the conditions of approval that is attached to this permit!! Contact this office if you have any questions.**
- **Permits expire in 6 months. If the project is not started or ceases for 6 months.**
- **If the inspection requirements are not followed as stated below additional fees may be incurred due to the issuance of a "Stop Work Order" and subsequent release to continue.**

The project cannot move to the next phase prior to the required inspection and approval to continue, REGARDLESS OF THE NOTICE OF CIRCUMSTANCES.

IF THE PERMIT REQUIRES A CERTIFICATE OF OCCUPANCY, IT MUST BE PAID FOR AND ISSUED TO THE OWNER OR DESIGNEE BEFORE THE SPACE MAY BE OCCUPIED.

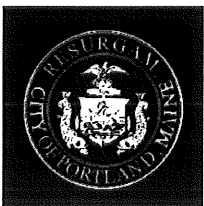

# PORTLAND MAINE

*Strengthening a Remarkable City, Building a Community for Life* • [www.portlandmaine.gov](http://www.portlandmaine.gov)

Director of Planning and Urban Development  
Penny St. Louis

Job ID: 2011-04-878-HVAC

Located At: 12 YALE

CBL: 436 - - A - 005 - 001 - - - -

## Conditions of Approval:

### **Zoning**

1. This is NOT an approval for an additional dwelling unit. You SHALL NOT add any additional kitchen equipment including, but not limited to items such as stoves, microwaves, refrigerators, or kitchen sinks, etc. without special approvals.
2. This property shall remain a single family dwelling. Any change of use shall require a separate permit application for review and approval.
3. Separate permits shall be required for future decks, sheds, pools, and/or garages.
4. All conditions on the original permit #10-1305 are still in force.

### **Building**

The installation must comply with the State of Maine gas regulations.

**City of Portland, Maine - Building or Use Permit Application**  
 389 Congress Street, 04101 Tel: (207) 874-8703, FAX: (207) 8716

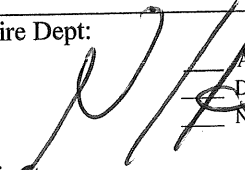
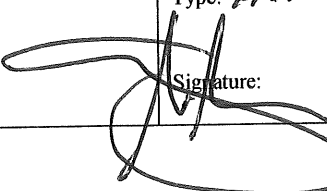
Job No: 2011-04-878-HVAC	Date Applied: 4/21/2011	CBL: 436 - - A - 005 - 001 - - - - -	
Location of Construction: 12 YALE ST	Owner Name: MJ DEVELOPMENT COMPANY LLC	Owner Address: 31 OLD CAMPUS DR PORTLAND, ME - MAINE 04103	Phone:
Business Name:	Contractor Name: JAMES M JACKSON,	Contractor Address: 30 BOLTON ST PORTLAND MAINE 04102	Phone: ( ) - 831-1810
Lessee/Buyer's Name:	Phone:	Permit Type: HVAC - HVAC	Zone: R-3
Past Use:  Single family dwelling under permit # 10-1305	Proposed Use:  Same - Single Family Dwelling - to install heating system	Cost of Work: \$4000.00	CEO District:
		Fire Dept:  Approved Denied N/A	Inspection: Use Group: R-3 Type: HVAC
		Signature:	Signature: 
Proposed Project Description: 12 Yale Street - to install heating system		Pedestrian Activities District (P.A.D.)	

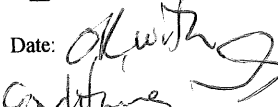
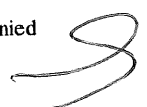
Permit Taken By: Gayle	<b>Zoning Approval</b>		
1. This permit application does not preclude the Applicant(s) from meeting applicable State and Federal Rules. 2. Building Permits do not include plumbing, septic or electrical work. 3. Building permits are void if work is not started within six (6) months of the date of issuance. False informatin may invalidate a building permit and stop all work.	<b>Special Zone or Reviews</b> <input type="checkbox"/> Shoreland <input type="checkbox"/> Wetlands <input type="checkbox"/> Flood Zone <input type="checkbox"/> Subdivision <input type="checkbox"/> Site Plan _ Maj _ Min _ MM Date: 	<b>Zoning Appeal</b> <input type="checkbox"/> Variance <input type="checkbox"/> Miscellaneous <input type="checkbox"/> Conditional Use <input type="checkbox"/> Interpretation <input type="checkbox"/> Approved <input type="checkbox"/> Denied Date:	<b>Historic Preservation</b> <input checked="" type="checkbox"/> Not in Dist or Landmark <input type="checkbox"/> Does not Require Review <input type="checkbox"/> Requires Review <input type="checkbox"/> Approved <input type="checkbox"/> Approved w/Conditions <input type="checkbox"/> Denied Date: 
	<b>CERTIFICATION 4/26/11</b>		

I hereby certify that I am the owner of record of the named property, or that the proposed work is authorized by the owner of record and that I have been authorized by the owner to make this application as his authorized agent and I agree to conform to all applicable laws of this jurisdiction. In addition, if a permit for work described in the appication is issued, I certify that the code official's authorized representative shall have the authority to enter all areas covered by such permit at any reasonable hour to enforce the provision of the code(s) applicable to such permit.

SIGNATURE OF APPLICANT	ADDRESS	DATE	PHONE
RESPONSIBLE PERSON IN CHARGE OF WORK, TITLE		DATE	PHON





FILL IN AND SIGN WITH INK

# APPLICATION FOR PERMIT HEATING OR POWER EQUIPMENT



436 A 005 SF

To the INSPECTOR OF BUILDINGS, PORTLAND, ME.

The undersigned hereby applies for a permit to install the following heating, cooking or power equipment in accordance with the Laws of Maine, the Building Code of the City of Portland, and the following specifications:

Location / CBL 12 Yale St Use of Building single Date 4-20-11  
 Name and address of owner of appliance Jim Wescott  
12 Yale St, Portland  
 Installer's name and address Portland PTH 30 Bolles St Portland  
 Telephone 207-831-1810

**Location of appliance:**  
 Basement       Floor  
 Attic               Roof

**Type of Fuel:**  
 Gas       Oil       Solid

**Appliance Name:** Prestige Excellence  
 U.L. Approved  Yes  No

Will appliance be installed in accordance with the manufacture's installation instructions?  Yes       No

IF NO Explain: \_\_\_\_\_

**The Type of License of Installer:**  
 Master Plumber # 2731  
 Solid Fuel # \_\_\_\_\_  
 Oil # \_\_\_\_\_  
 Gas # PAT 8408  
 Other \_\_\_\_\_

**Type of Chimney:**  
 Masonry Lined  
 Factory built \_\_\_\_\_  
 Metal  
 Factory Built U.L. Listing # \_\_\_\_\_  
 Direct Vent  
 Type PVC UL# \_\_\_\_\_

**Type of Fuel Tank**  
 Oil  
 Gas

**Size of Tank** \_\_\_\_\_

**Number of Tanks** \_\_\_\_\_

**Distance from Tank to Center of Flame** \_\_\_\_\_ feet.

**Cost of Work:** \$ 3500  
**Permit Fee:** \$ 60.00

**RECEIVED**  
 APR 21 2011  
 Dept. of Building Inspections  
 City of Portland Maine

**Approved**      **Approved with Conditions**

Fire: \_\_\_\_\_       See attached letter or requirement  
 Ele.: \_\_\_\_\_  
 Bldg.: \_\_\_\_\_

Signature of Installer James M. Jack      Inspector's Signature \_\_\_\_\_      Date Approved \_\_\_\_\_

White - Inspection      Yellow - File      Pink - Applicant's      Gold - Assessor's Copy

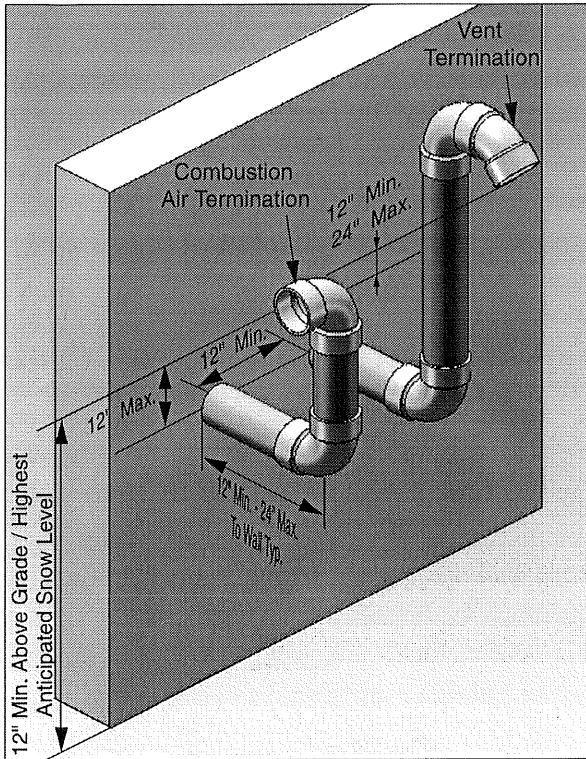

Fig. 12: Direct Vent - Sidewall Snorkel Termination of Vent and Combustion Air Piping with 45° Vent Termination

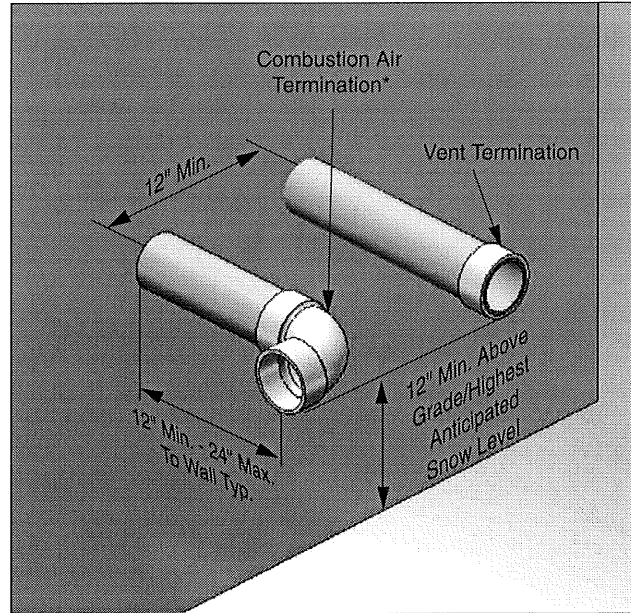

Fig. 13: Direct Vent - Sidewall Termination of Vent and Combustion Air Piping with Coupling Vent Termination

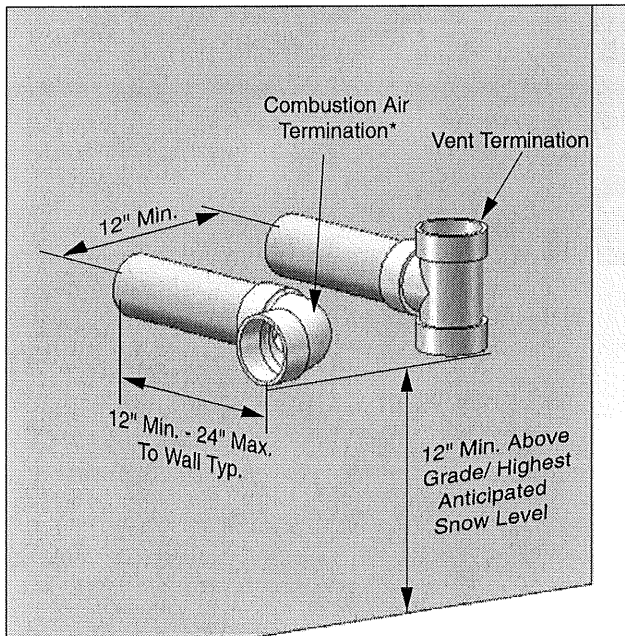

Fig. 14: Direct Vent - Sidewall Termination of Vent and Combustion Air Piping with Tee Vent Termination

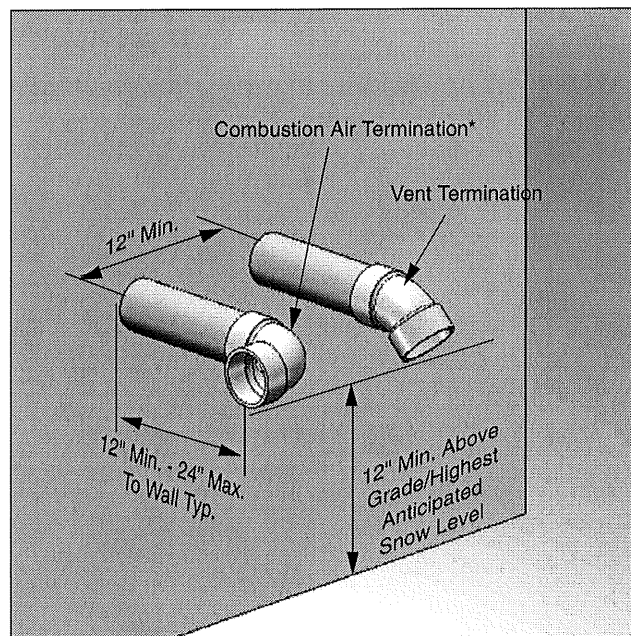

Fig. 15: Direct Vent - Sidewall Termination of Vent and Combustion Air Piping with 45° Vent Termination

**NOTICE** \* Combustion Air Termination should slope downward at 15° angle.

Memorandum  
Department of Planning and Urban Development  
Planning Division

---



TO: Inspections Department

FROM: Philip DiPierro, Development Review Coordinator

DATE: April 28, 2011

RE: C. of O. for # 12 Yale Street, Lot #1, Wescott Single Family  
(Id#2009-0053) (CBL 436 A 005001)

---

After visiting the site, I have the following comments:

Site work complete:

At this time, I recommend issuing

878-5216

Cc: Tammy Munson, Inspection Services Manager  
File: Barbara Barhydt, Development Review Services Manager  
File: Urban Insight