



**Customer Information**

**Name:** DAVID ROWE  
**Address:** 241 PERKINS RIDGE RD  
 AUBURN, ME 04210  
**Primary Phone:** 207-619-3655  
**Secondary Phone:** 207-650-5778

**Store Information**

**PORTLAND**  
 245 RIVERSIDE STREET  
 PORTLAND, ME 04103  
**Store Number:** 2401  
**Customer Agreement # :** 353751  
**Associate:** MICHAEL

Line #	Product Description	Qty	Unit Price	Total Price
--------	---------------------	-----	------------	-------------

100-1 70 Series NFJ Double-Hung-3001,3901  
 36 x 48  
 Standard Width = RO: 36 1/2" | UNIT: 36"  
 Standard Height = RO: 48 1/2" | UNIT: 48"  
 Frame Width = 36  
 Frame Height = 48  
 Unit Code = 30.25x40  
 Exterior Color = White  
 Interior Finish Color = White  
 Glass Option = Low-E2  
 High Altitude Breather Tubes = No  
 Glass Strength = Standard  
 Glass Tint = No Tint  
 Specialty Glass = None  
 Number of Sash Locks = Double  
 Lock Type = Standard  
 None  
 Insect Screen Type = Full Screen  
 Insect Screen Material = Fiberglass  
 Exterior Trim Style = None  
 Drywall Return = No  
 J-Channel Filler = No  
 Extension Jamb Type = None  
 Room Location = None  
 Unit U-Factor = 0.33  
 Unit Solar Heat Gain Coefficient (SHGC) = 0.29  
 U.S. ENERGY STAR Qualified = No  
 Installation Zip Code = 04103,  
 U.S. ENERGY STAR® Climate Zone = Northern  
 Performance Grade (PG) Rating = PG50  
 SKU = 239574  
 Vendor Name = S/O SILVER LINE BLDG PRD  
 Vendor Number = 60660514  
 Customer Service = (888) 888-7020  
 Catalog Version Date = 10/24/2014

2 Was: ~~\$193.38~~ **\$386.76**  
 Now: **\$164.37** **\$328.74**  
 Save \$58.02 (15.0%) until 11/19/2014  
 \* S/O SILVER LINE BLDG  
 PRD-239574 Promotion until  
 11/19/2014

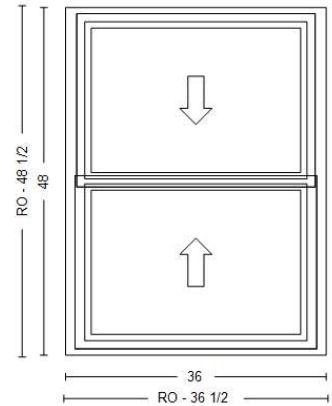

Line #	Product Description	Qty	Unit Price	Total Price
--------	---------------------	-----	------------	-------------

200-1 70 Series NFJ Double-Hung-3001,3901  
 23.75 x 38  
 Standard Width = RO: 24 1/4" | UNIT: 23 3/4"  
 Standard Height = RO: 38 1/2" | UNIT: 38"  
 Frame Width = 23 3/4  
 Frame Height = 38  
 Unit Code = 20x32  
 Exterior Color = White  
 Interior Finish Color = White  
 Glass Option = Low-E2  
 High Altitude Breather Tubes = No  
 Glass Strength = Standard  
 Glass Tint = No Tint  
 Specialty Glass = None  
 Number of Sash Locks = Single  
 Lock Type = Standard  
 None  
 Insect Screen Type = Full Screen  
 Insect Screen Material = Fiberglass  
 Exterior Trim Style = None  
 Drywall Return = No  
 J-Channel Filler = No  
 Extension Jamb Type = None  
 Room Location = None  
 Unit U-Factor = 0.33  
 Unit Solar Heat Gain Coefficient (SHGC) = 0.29  
 U.S. ENERGY STAR Qualified = No  
 Installation Zip Code = 04103,  
 U.S. ENERGY STAR® Climate Zone = Northern  
 Performance Grade (PG) Rating = PG50  
 SKU = 239574  
 Vendor Name = S/O SILVER LINE BLDG PRD  
 Vendor Number = 60660514  
 Customer Service = (888) 888-7020  
 Catalog Version Date = 10/24/2014

1 Was: ~~\$156.58~~ \$156.58  
 Now: **\$133.09** **\$133.09**  
 Save \$23.49 (15.0%) until 11/19/2014  
 \* S/O SILVER LINE BLDG  
 PRD-239574 Promotion until  
 11/19/2014

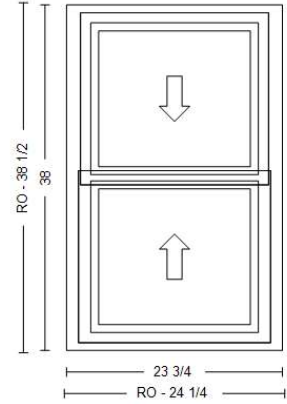

Line #	Product Description	Qty	Unit Price	Total Price
--------	---------------------	-----	------------	-------------

300-1 70 Series NFJ Single-Hung-2901  
 32 x 36  
 Standard Width = RO: 32 1/2" | UNIT: 32"  
 Standard Height = RO: 36 1/2" | UNIT: 36"  
 Frame Width = 32  
 Frame Height = 36  
 Unit Code = 28x30  
 Drywall Access = No  
 Exterior Color = White  
 Interior Finish Color = White  
 Glass Option = Low-E2  
 High Altitude Breather Tubes = No  
 Glass Strength = Standard  
 Glass Tint = No Tint  
 Specialty Glass = None  
 Hardware Color/Finish = White  
 Number of Sash Locks = Double  
 Lock Type = Standard  
 None  
 Insect Screen Type = Half Screen  
 Insect Screen Material = Fiberglass  
 Drywall Return = No  
 J-Channel Filler = No  
 Extension Jamb Type = None  
 Room Location = None  
 Unit U-Factor = 0.33  
 Unit Solar Heat Gain Coefficient (SHGC) = 0.3  
 U.S. ENERGY STAR Qualified = No  
 Installation Zip Code = 04103,  
 U.S. ENERGY STAR® Climate Zone = Northern  
 Performance Grade (PG) Rating = PG50  
 Foam = No  
 SKU = 261463  
 Vendor Name = S/O SILVER LINE BLDG PRD  
 Vendor Number = 60660514  
 Customer Service = (888) 888-7020  
 Catalog Version Date = 10/24/2014

1 Was: ~~\$125.12~~ \$125.12  
 Now: **\$106.36** **\$106.36**  
 Save \$18.76 (15.0%) until 11/19/2014  
 \* S/O SILVER LINE BLDG  
 PRD-261463 Promotion until  
 11/19/2014

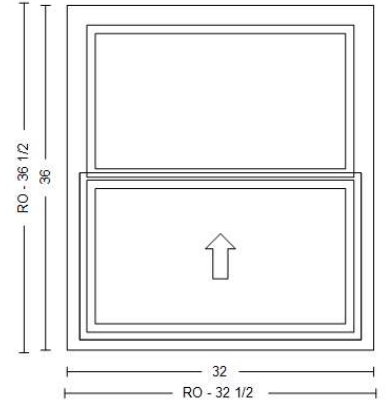

# Quote Summary:

Line#	Item Summary	Was Price	Now Price	Qty	Total Unit Savings	Total Price
100-1	70 Series NFJ Double-Hung-3001,3901 Equal Sash , , 36 x 48 , / White - White	\$193.38	\$164.37	2	(\$58.01)	\$328.74
200-1	70 Series NFJ Double-Hung-3001,3901 Equal Sash , , 23.75 x 38 , / White - White	\$156.58	\$133.09	1	(\$23.49)	\$133.09
300-1	70 Series NFJ Single-Hung-2901 Equal Sash , Fixed/Active , 32 x 36 , / White - White	\$125.12	\$106.36	1	(\$18.77)	\$106.36
<b>Pre-Savings Total:</b>						<b>\$668.46</b>
<b>Total Savings:</b>						<b>(\$100.27)</b>
<b>Pre-tax Customer Price:</b>						<b>\$568.19</b>
<b>Pricing Valid Through 11/19/2014</b>						



## Limited Lifetime Warranty

### Residential Vinyl Windows and Patio Doors

1. Subject to the terms and conditions stated herein, the manufacturer warrants to the Original Purchaser that under the conditions of normal use and service, all window and/or patio door products, including mechanical parts and insulated glass, will be free from the following defects in material and workmanship for the lifetime of the product:

- a) Vinyl products will be free from blistering, peeling, flaking, rotting or corrosion.
- b) There will be no material obstruction of vision on the internal surfaces of the insulated glass unit caused by sealant failure of the insulated glass unit.
- c) Component parts will be free from any and all manufacturing defects.

In the event that the Original Purchaser experiences a problem with respect to any of the defects set forth in Section 1a, b or c above, a new replacement part will be provided upon receipt of the original part or validation of the complaint. The manufacturer reserves the right to require return of the defective part(s).

2. The warranties described above cover only manufacturing defects and do not include defects or damages caused by, or as the result of, any of the following circumstances:

- a) The improper installation or use of the product or products by the Original Purchaser, his agents, assigns or invitees.
- b) The improper application or use of the product.
- c) The occurrence of accidents, vandalism, fire, floods, acts of God including, but not limited to, earthquakes and hurricanes.
- d) Any modification or alteration to the product.
- e) The failure to perform reasonable and necessary maintenance on the product or products.
- f) The neglect, abuse, improper handling and/or improper storage of the product.
- g) Exposure of the product to excessive heat and/or cold beyond naturally occurring conditions.
- h) Stresses caused by building defects or settlement or movement of the structure in which it was installed.
- i) The application of harmful cleaning solutions or products including, but not limited to, acetone, petroleum products or abrasive compounds.
- j) Misalignment of grilles/muntins of 1/8" or less from appropriate position.
- k) Slight fading and/or color variations caused by normal aging or weathering.
- l) Torn or ripped screens for any cause whatsoever.
- m) The improper removal of any permanent warning or identification labels from the product or products.
- n) The rusting or corrosion of non-vinyl products or components due to the close proximity to coastal areas unless the product is composed of appropriate stainless steel or other non-corrosive hardware.
- o) Installation of the product or products outside of the 48 contiguous United States.
- p) Any inappropriate or unintended use or uses of the product including, but not limited to, any commercial use.

3. With respect to insulated glass product, the above warranties cover only manufacturing defects related to the insulated glass unit and does not include defects or damages caused by, or as the result of, the following circumstances:

- a) Minor blemishes in the glass that do not significantly impair the structure or vision through the glass including glass curvature.
- b) Color variation or variations of the glass.
- c) Glass breakage for any cause or any reason.
- d) Subjection to stresses arising from glass surface temperature differentials or caused by building settlement or movement.
- e) Condensation on the external surfaces of the window and/or glass, which may occur as the natural result of humidity and interior/external temperature differentials.



- f) The transportation or installation of the glass product or products at altitudes in excess of 3,500 feet above or below point of manufacture unless equipped with capillary or breather tubes.
  - g) The very gradual, natural migration of inert gas infills used in insulated glass units.
  - h) Improper application, alteration, modification, or use of the insulated glass units, including the application of aftermarket films.
4. For quality assurance purposes, all window and patio door products should be inspected by the Original Purchaser prior to, or at the time of installation or upon transfer of title to the Original Occupant.
  5. Commercial Applications - If the products are installed in a building operated as a multi-family dwelling or used for commercial purposes or rental properties such as schools, houses of worship, apartment complexes, government owned structures, office buildings, etc., then this Warranty will be limited to ten (10) years on all materials and will not be transferable.
  6. The warranties set forth above are expressly in lieu of all other expressed warranties and of all other obligations or liabilities on the manufacturer's part. The manufacturer neither assumes, nor authorizes any other person to assume for the manufacturer, another liability in connection with the sale of the product. The warranties as described herein are the exclusive remedies for breach. There are no warranties that extend beyond the description on the face of this document. The manufacturer makes no warranty whatsoever with respect to accessories or parts not supplied by the manufacturer.
  7. The warranties cover materials only and the manufacturer does not assume any expense or responsibility involved with the removal and/or reinstallation of any replacement parts. The manufacturer's obligation under the warranties is expressly limited to, at the manufacturer's option, replacement or repair of any defective part or component. The manufacturer reserves the right to discontinue the model or models manufactured under these warranties. Any discontinued parts or components may be replaced with an equivalent part at the sole discretion of the manufacturer. The manufacturer is not responsible for any color variation in the replacement part or component. The manufacturer is not responsible for any window which has been modified in any manner to accommodate an alarm system which may be attached to the product nor is it responsible for the reconnecting of the window to the alarm system. The manufacturer reserves the right to inspect any and all defects in the field. Field visitation(s) may result in service charges for non-warranty site surveys.
  8. Under no circumstances is the manufacturer liable for consequential, exemplary or special damages including, but not limited to, damage or loss of other property or equipment.
  9. Some states do not allow limitations on how long an implied warranty lasts and/or the exclusion or limitation of incidental or consequential damages, so the above limitations may not apply to you. These warranties give you specific legal rights and you may also have other rights which vary from state to state.
  10. ELIGIBILITY REQUIREMENTS: Enforceability of the warranties set forth above are limited to the Original Purchaser. The term "Original Purchaser" as used in the warranties means:

That individual, individuals or entity which took original title to the premises or are the original occupants of the structure in which the product was installed.

Any inquiry with respect to the product must be made in writing and include the Original Purchaser's name, address, date of purchase, product information from the product label and daytime as well as evening telephone numbers.

All claims and/or inquiries should be forwarded to the following address: American Craftsman Window & Door Company  
Attn: Warranty/Registration Department  
P.O. Box 6029  
North Brunswick, New Jersey 08902-6029

11. NON-TRANSFERABILITY: The warranties described above are non-transferable and limited to the Original Purchaser as described in Section 10 above.
12. If any part of the warranties described above are void or unenforceable in any State of the United States, the remaining portions will nonetheless continue in full force and effect.