

City of Portland, Maine - Building or Use Permit Application

389 Congress Street, 04101 Tel: (207) 874-8703, FAX: (207) 8716

Job No: 2012-09-4968-ALTR #2012-50367 HVAC	Date Applied: 11/20/2012	CBL: 431- B-007-001	
Location of Construction: 74 WATSON ST	Owner Name: DONALD PETERSON	Owner Address: 10 ISLAND STREET PORTLAND, ME 04103	Phone:
Business Name:		Contractor Address: NESTBROOK MAINE 04092	Phone: 650-0611
Lessee/Buyer's Name:	CLOSED		Zone: R-3
Past Use: Single Family Dwelling	Same: Single Family Dwelling to install new heating system - Laars Mascott II		CEO District:
Proposed Project Description: new HVAC		Inspection: Use Group: Type: <i>W/C</i> Approved Denied N/A Signature: <i>[Signature]</i>	
Permit Taken By: Brad	Pedestrian Activities District (P.A.D.)		

1. This permit application does not preclude the Applicant(s) from meeting applicable State and Federal Rules. 2. Building Permits do not include plumbing, septic or electrical work. 3. Building permits are void if work is not started within six (6) months of the date of issuance. False informatin may invalidate a building permit and stop all work.	Zoning Approval		
	Special Zone or Reviews <input type="checkbox"/> Shoreland <input type="checkbox"/> Wetlands <input type="checkbox"/> Flood Zone <input type="checkbox"/> Subdivision <input type="checkbox"/> Site Plan Date: <i>ok [Signature]</i> 11/20/12	Zoning Appeal <input type="checkbox"/> Variance <input type="checkbox"/> Miscellaneous <input type="checkbox"/> Conditional Use <input type="checkbox"/> Interpretation <input type="checkbox"/> Approved <input type="checkbox"/> Denied Date:	Historic Preservation <input checked="" type="checkbox"/> Not in Dist or Landmark <input type="checkbox"/> Does not Require Review <input type="checkbox"/> Requires Review <input type="checkbox"/> Approved <input type="checkbox"/> Approved w/Conditions <input type="checkbox"/> Denied Date: <i>[Signature]</i>

SCANNED

CERTIFICATION

I hereby certify that I am the owner of record of the named property, or that the proposed work is authorized by the owner of record and that I have been authorized by the owner to make this application as his authorized agent and I agree to conform to all applicable laws of this jurisdiction. In addition, if a permit for work described in the application is issued, I certify that the code official's authorized representative shall have the authority to enter all areas covered by such permit at any reasonable hour to enforce the provision of the code(s) applicable to such permit.

SIGNATURE OF APPLICANT	ADDRESS	DATE	PHONE
RESPONSIBLE PERSON IN CHARGE OF WORK, TITLE	DATE		PHONE

2-12-13

G/BKL

MASCOT G.7 CONDENSATE DRAINS

510.9 UPC

SEE BRIAW

① NEEDS GFCI @ BOILER W/ W/ 60W
PIES

DISPLAY THIS CARD ON PRINCIPAL FRONTAGE OF WORK



CITY OF PORTLAND

BUILDING PERMIT

This is to certify that Donald Peterson

Located At 74 WATSON ST

Job ID: 2012-09-4968-ALTR

CBL: 431- B-007-001

has permission to Install an HVAC system (Single Family Residence).

provided that the person or persons, firm or corporation accepting this permit shall comply with all of the provisions of the Statues of Maine and of the Ordinances of the City of Portland regulating the construction, maintenance and use of the buildings and structures, and of the application on file in the department.

Notification of inspection and written permission procured before this building or part thereof is lathed or otherwise closed-in. 48 HOUR NOTICE IS REQUIRED.

A final inspection must be completed by owner before this building or part thereof is occupied. If a certificate of occupancy is required, it must be

Fire Prevention Officer

Code Enforcement Officer / Plan Reviewer

12/11/2012

THIS CARD MUST BE POSTED ON THE STREET SIDE OF THE PROPERTY
PENALTY FOR REMOVING THIS CARD

SCANNED

BUILDING PERMIT INSPECTION PROCEDURES

Please call 874-8703 or 874-8693 (ONLY)

or email: buildinginspections@portlandmaine.gov

With the issuance of this permit, the owner, builder or their designee is required to provide adequate notice to the city of Portland Inspections Services for the following inspections. Appointments must be requested 48 to 72 hours in advance of the required inspection. The inspection date will need to be confirmed by this office.

- **Please read the conditions of approval that is attached to this permit!! Contact this office if you have any questions.**
 - **Permits expire in 6 months. If the project is not started or ceases for 6 months.**
 - **If the inspection requirements are not followed as stated below additional fees may be incurred due to the issuance of a "Stop Work Order" and subsequent release to continue.**
1. Close-In: Electrical, Plumbing and Framing
 2. Final Inspection

The project cannot move to the next phase prior to the required inspection and approval to continue, REGARDLESS OF THE NOTICE OF CIRCUMSTANCES.

IF THE PERMIT REQUIRES A CERTIFICATE OF OCCUPANCY, IT MUST BE PAID FOR AND ISSUED TO THE OWNER OR DESIGNEE BEFORE THE SPACE MAY BE OCCUPIED.



PORTLAND MAINE

Strengthening a Remarkable City, Building a Community for Life • www.portlandmaine.gov

Director of Planning and Urban Development
Jeff Levine

Job ID: 2012-09-4968-ALTR

Located At: 74 WATSON ST

CBL: 431- B-007-001

Conditions of Approval:

Building

1. The installation must comply with UL, the Manufacturers' Listing, MUBEC (IRC, 2009), and State of Maine Gas Regulations.
2. Separate permits are required for any electrical: plumbing, sprinkler, fire alarm, HVAC systems, commercial hood exhaust systems and fuel tanks. Separate plans may need to be submitted for approval as a part of this process.
3. Maintain proper setback(s) from property lines/buildings and proper clearances from vertical openings when direct venting
4. A Carbon Monoxide (CO) alarm shall be installed in each area within or giving access to bedrooms. That detection must be powered by the electrical service (plug-in or hardwired) in the building and battery.

	U.S. Installations (see note 1)	Canadian Installations (see note 2)
A= Clearance above grade, veranda, porch, deck, or balcony	12 inches (30 cm) See note 6	12 inches (30 cm) See note 6
B= Clearance to window or door that may be opened	Direct vent only: 12 inches (30cm); Other than Direct vent: 4 ft (1.2m) below or to side of opening; 1 ft (30cm) above opening	36 inches (91 cm)
C= Clearance to permanently closed window	See note 4	See note 5
D= Vertical clearance to ventilated soffit located above the terminal within a horizontal distance of 2 feet (61cm) from the center line of the terminal	See note 4	See note 5
E= Clearance to unventilated soffit	See note 4	See note 5
F= Clearance to outside corner	See note 4	See note 5
G= Clearance to inside corner	3 feet (91 cm) minimum	See note 5
H= Clearance to each side of center line extended above meter/regulator assembly	See note 4	3 feet (91 cm) within a height 15 feet above the meter/regulator assembly
I= Clearance to service regulator vent outlet	See note 4	3 feet (91 cm)
J= Clearance to nonmechanical air supply inlet to building or the combustion air inlet to any other appliance	Direct vent only: 12" (30cm) 80-285; 36" (91cm) 399-850. Other than Direct vent: 4 ft (1.2m) below or to side of opening; 1 ft (30cm) above opening	36 inches (91 cm)
K= Clearance to a mechanical air supply inlet	3 feet (91 cm) above if within 10 feet (3 m) horizontally	6 feet (1.83 m)
L= Clearance above paved sidewalk or paved driveway located on public property	Vent termination not allowed in this location for category IV appliances.	Vent termination not allowed in this location for category IV appliances.
M= Clearance under veranda, porch, deck, or balcony	See note 4	12 inches (30 cm) (see note 3)

Notes:

1. In accordance with the current ANSI Z223.1 / NFPA 54 National Fuel Gas Code.
2. In accordance with the current CAN/CGA-B149 Installation Codes.
3. Permitted only if veranda, porch, deck, or balcony is fully open on a minimum of two sides beneath the floor.
4. For clearances not specified in ANSI Z223.1 / NFPA 54, clearance is in accordance with local installation codes and the requirements of the gas supplier.
5. For clearances not specified in CAN/CGA-B149, clearance is in accordance with local installation codes and the requirements of the gas supplier.
6. **IMPORTANT:** terminal must be placed such that it remains a minimum 12" above expected snow line. Local codes may have more specific requirements, and must be consulted.

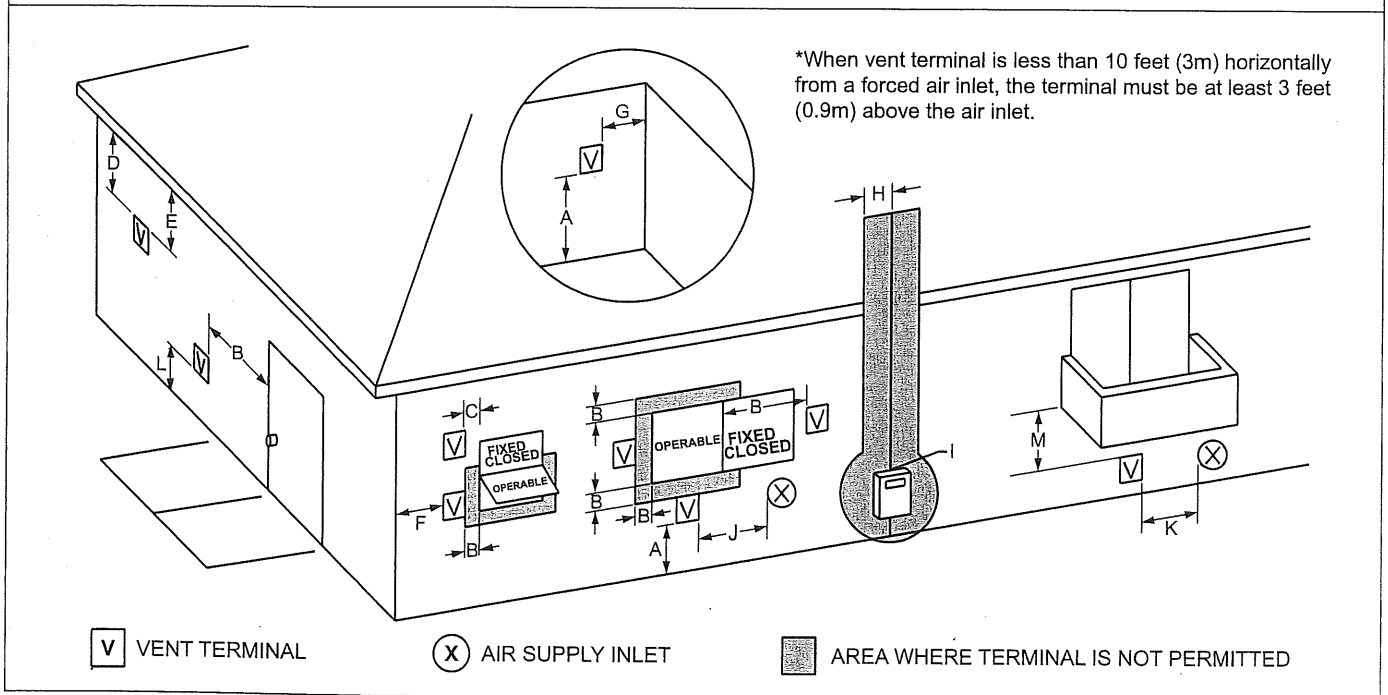
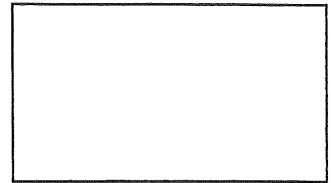

Figure 9. Combustion Air and Vent Through Side Wall.



FILL IN AND SIGN WITH INK

APPLICATION FOR PERMIT HEATING OR POWER EQUIPMENT



2012-09-4568-ALTR

Entire 11/18/12 (85)
2012-58367

To the INSPECTOR OF BUILDINGS, PORTLAND, ME.

The undersigned hereby applies for a permit to install the following heating, cooking or power equipment in accordance with the Laws of Maine, the Building Code of the City of Portland, and the following specifications:

Location / CBL 74 Watson St 431 3007 & 2 Use of Building residential Date 11/21/12
 Name and address of owner of appliance JIM'S PH
89 Lamb St Westbrook
 Installer's name and address JIM'S PH (SAME)
 Telephone 207 650 0611

Location of appliance:

- Basement
- Attic
- Floor
- Roof

Type of Fuel:

- Gas
- Oil
- Solid

Appliance Name:

U.L. Approved Yes No

Will appliance be installed in accordance with the manufacture's installation instructions? Yes No

IF NO Explain: _____

The Type of License of Installer:

- Master Plumber # 01958
- Solid Fuel # _____
- Oil # _____
- Gas # DNT 545
- Other _____

Type of Chimney:

- Masonry Lined
Factory built NA
- Metal
Factory Built U.L. Listing # _____
- Direct Vent Lorrs
Type MASCOTT II UL# _____

Type of Fuel Tank

- Oil
- Gas

Size of Tank NATURAL

Number of Tanks _____

Distance from Tank to Center of Flame _____ feet.

Cost of Work: \$ 8000

Permit Fee: \$ 100.00

Approved

Fire: _____

Ele.: _____

Bldg.: _____

Signature of Installer

Approved with Conditions

- See attached letter or requirement

Inspector's Signature

Date Approved

White - Inspection

Yellow - File

Pink - Applicant's

Gold - Assessor's Copy



PORTLAND MAINE

Strengthening a Remarkable City, Building a Community for Life • www.portlandmaine.gov

Receipts Details:

Tender Information: Check , Check Number: 873\$190.00

Tender Amount: 190.00

Receipt Header:

Cashier Id: bsaucier

Receipt Date: 11/19/2012

Receipt Number: 50368

Receipt Details:

Reference ID:	8788	Fee Type:	BP-Plumbing
Receipt Number:	0	Payment Date:	
Transaction Amount:	90.00	Charge Amount:	90.00
Job ID: Job ID: 2012-09-4968-ALTR - Renovations of porch, kitchen & bath			
Additional Comments: 74 Watson			

Reference ID:	8789	Fee Type:	BP-HVAC
Receipt Number:	0	Payment Date:	
Transaction Amount:	100.00	Charge Amount:	100.00
Job ID: Job ID: 2012-09-4968-ALTR - Renovations of porch, kitchen & bath			
Additional Comments:			

Thank You for your Payment!

High Efficiency Mascot® II Boilers

The Mascot II is a 125 MBTU heating only or combination ("Combi" - heating and domestic hot water) wall mounted boiler packed with features and benefits that both the homeowner and contractor can enjoy.

For the homeowner, the Mascot II offers a 95% plus efficiency rating for lower operating costs, has "zero clearance installation" so it can fit just about anywhere and has a modern appliance design. It is a reliable, quiet, smooth operating boiler that has enough output to keep your home warm with continuous hot water for long relaxing showers.

Contractors will love the Mascot II because they install in less time than other units do, thanks to the service-friendly design and full package of system components. Components are easily accessible for disassembly, should an unlikely call for service be required, saving service time and money.

Boiler setup is a breeze because of full access to both the gas valve and control panel at the same time (see figure on following page). The gas valve is accessible directly behind the front lower panel that rotates down via a hinged connection. While the lower panel is open, the center console that houses the control display remains closed and fully visible.

- Sleek, appliance-grade cabinet that looks great in any location
- 95% AFUE efficiency, condensing operation
- 2-year parts warranty, 12-year heat exchanger warranty
- Energy Star qualified
- Zero Installation Clearance
- Sealed combustion
- Direct spark ignition for smooth reliable starts
- Two venting options to meet the needs of almost any installation
- Optimized gas usage for lower energy bills via 20% to 100% input modulating gas valve
- Quiet variable speed blower
- Boilers are set up for natural gas, no parts necessary for conversion to LP gas
- Built in expansion tank that will handle 26 gallons of system water (enough to cover 1,800 feet of ½" PEX tubing)
- Three speed circulator with air vent and "quick-remove" mounting system
- Automatic 3-way valve for DHW priority eliminates the need for separate zone setup when using an indirect DHW tank
- Mounting kit with template and wall bracket for fast and easy installation
- Light-weight (100 lbs.) makes handling easy
- Stainless steel A.S.M.E. primary heat exchanger with externally welded manifolds for better flow rates and prevention of leaks
- Stainless steel brazed plate DHW heat exchanger (combi models) with advanced flow switch
- Hydronic system water pressure sensor for safety at low water levels
- Advanced Laars integrated control system with temperature control, diagnostics, outdoor reset capability, and easy access for field wiring
- Unique, sealed condensate trap does not need to be primed at startup
- Pump Freeze Protection

LAARS 
Heating Systems Company
A subsidiary of BRADFORD WHITE Corporation

NOW WITH 100%
CUSTOMER SATISFACTION
GUARANTEE

LAARS® MASCOT® II

Gas-Fired Wall-Mounted
Combination Boiler &
Water Heater



LAARS®
Heating Systems Company
A subsidiary of BRADFORD WHITE® Corporation

THE MASCOT® II

- Operates quietly, smoothly and reliably
- Energy Star rated, 95% Efficient (AFUE)
- Low emissions, 10ppm NOx
- Zero installation clearance, fits almost anywhere
- Easy to install, setup and service
- 2 year parts, 12 year heat exchanger warranty



100% CUSTOMER SATISFACTION GUARANTEE

If your Mascot II requires more than two warranty service repairs during the first year of operation, we will replace the boiler at no charge!

This program rivals any in the industry. All you have to do is have the boiler installed and started up per the installation & operations manual and register with Laars via a 10-Point installation checklist. It's that simple, Laars is engineered to be the best.

Ask your local Laars representative for details.

MASCOT® II APPLICATIONS

- Perfect for radiant floor heating applications, and systems with large emitters - no restriction on low return water temperatures
- Approved for closet and alcove installations – perfect for condominiums and town homes
- Great for saving space by combining heating and domestic hot water in one small appliance

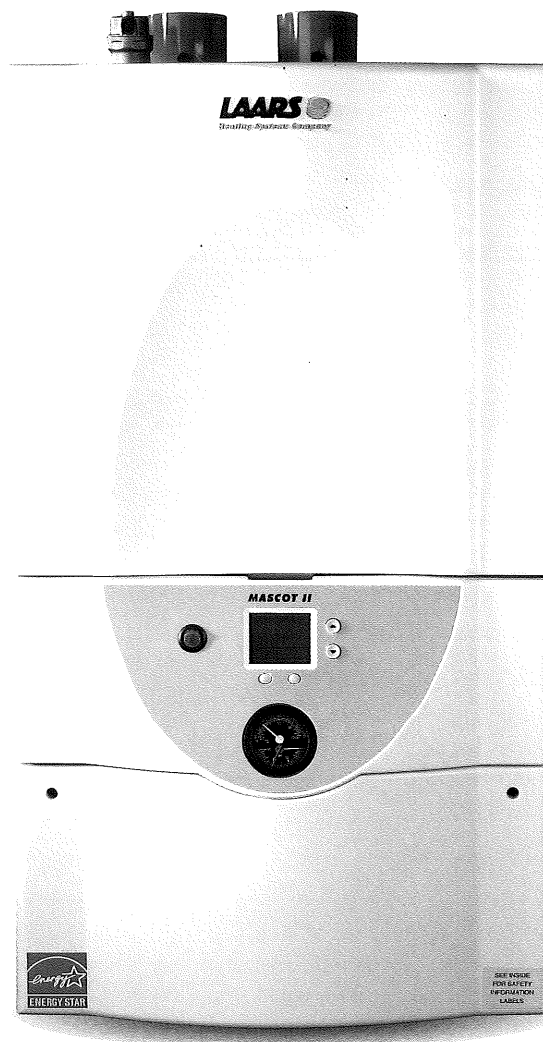

**American design, with clean
appliance look and feel**

LAARS 
Heating Systems Company
A subsidiary of **BRADFORD WHITE** Corporation

LAARS® MASCOT® II DIMENSIONS

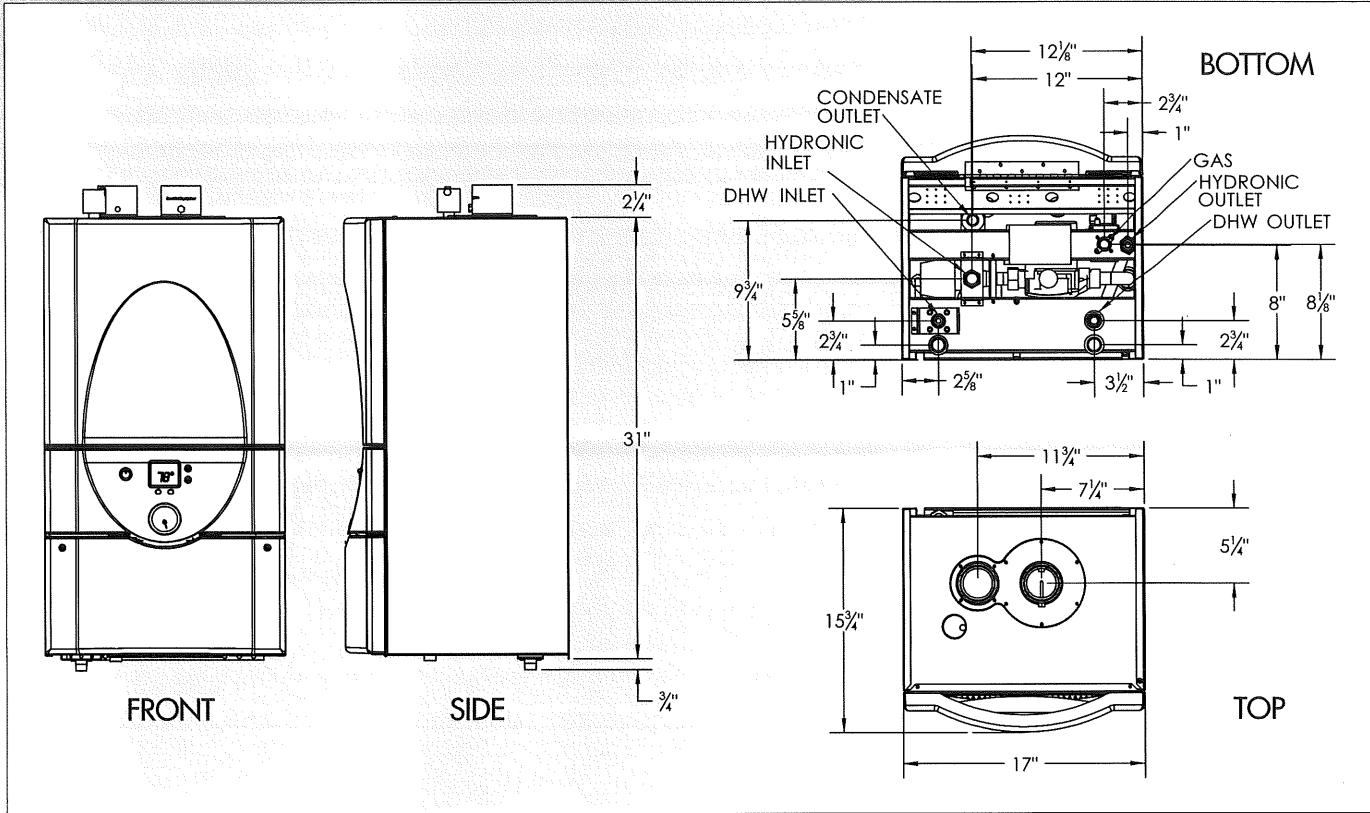

LAARS® MASCOT® II SPECIFICATIONS

DESCRIPTION	MASCOT II - 125	
	Natural Gas / LP Gas	
Input, max fire	125,000 BTU/hr	36.6 kW
Output, max fire	121,250 BTU/hr	35.5 kW
DHW Max Outlet Water Temp	180 °F	60 °C
DHW Max Flow Rate (dt@60°F)	4.0 gpm	15.1 l/m
Flow Rate, min	0.5 gpm	1.9 l/m
Pressure Relief Setting	30 psi	207 kPa
Gas Connection	1/2	NPT
Supply Flow Connection	3/4	NPT
Return Flow Connection	3/4	NPT
Burner and Heat Exchanger Material	Stainless Steel	—
Weight	100 lbs	45.4 kg
Service Clearances		
Front and Bottom	24 in	61 cm
Top and Sides	6 in	15.2 cm
Air Vents		
Two Pipe Flue Terminal	2 in	5.1 cm
Concentric	3 / 5 in	7.6 / 12.7 cm
Electrical Supply		
Voltage	120 V	
Frequency	60 HZ	

MASCOT® II

INTELLIGENTLY DESIGNED

Air elimination valve

Concentric or two-pipe venting connections, two-pipe connection uses standard off the shelf PVC or CPVC piping.

A built in expansion tank eliminates unsightly externally mounted tanks

System is fully protected with resettable circuit breakers

Each Mascot II is supplied with a unique, sealed condensate trap that does not need priming at startup.

Laars advanced integrated control system

Each Mascot II uses a state of the art, condensing, stainless steel heat exchanger with a 5:1 turndown. The design delivers 95% AFUE, a low 10ppm NOx emissions and only 1.5 amp electrical draw resulting in one of the most environmentally friendly, compact, combination units on the market.

Every Mascot II is equipped with an advanced Laars integrated LCD push button control system, illuminated power switch and pressure gauge. Temperature control, diagnostics, outdoor reset capability and many other functions are seamlessly integrated in this one easy to use center console.

The Mascot II lower door opens independently from the rest of the unit allowing access to both the gas valve and controls at the same time, making setup very easy.

Mascot II boilers are designed with a built-in expansion tank, air elimination vent, three-speed circulator, primeless condensate trap and direct access to wiring. These features, along with a wall-mounting template, save contractors hundreds of dollars in material & labor and help reduce installation errors. Not to mention most components are "off the shelf" replacement parts and can easily be obtained from many distribution locations.

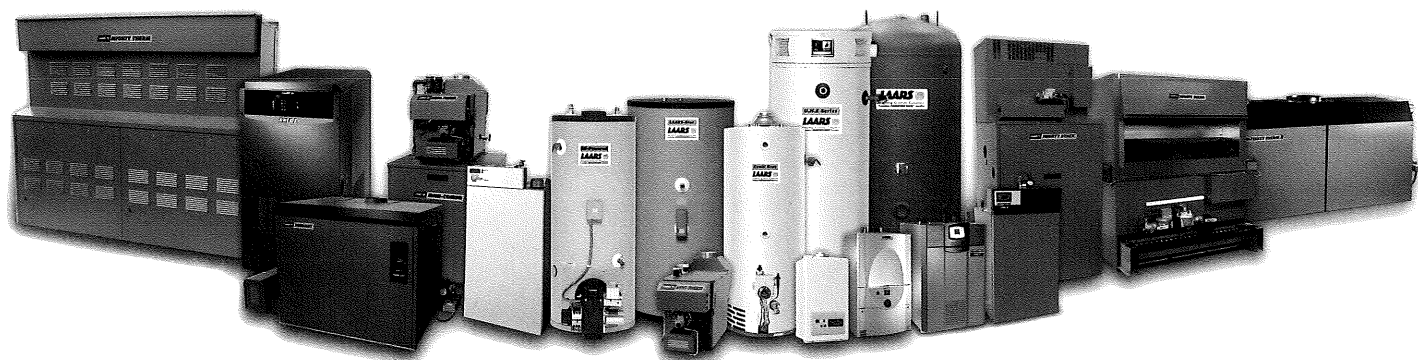

View our entire product line at www.Laars.com



LAARS[®] 
Heating Systems Company
 A subsidiary of **BRADFORD WHITE** Corporation

800.900.9276 • Fax 800.559.1583 (Customer Service, Service Advisors)
 20 Industrial Way, Rochester, NH 03867 • 603.335.6300 • Fax 603.335.3355 (Applications Engineering)
 1869 Sismet Road, Mississauga, Ontario, Canada L4W 1W8 • 905.238.0100 • Fax 905.366.0130

www.Laars.com