

Technical Data Manual

Model Nos. and pricing: see Price List



Vitodens 100-W, WB1B
(with preinstalled coaxial vent pipe adaptor)

Vitodens 100-W

WB1B Series

Gas-Fired Wall-Mounted Condensing Boiler
with modulating stainless steel Matrix cylinder burner and stainless steel Inox-Radial heat exchanger for room air independent operation (using a direct vent system) or room air dependent operation

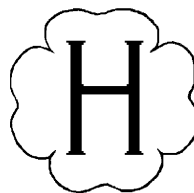

VITODENS 100-W

Equipped with a Viessmann stainless steel heat exchanger for lasting performance and reliability and a modulating Matrix cylinder gas burner, the Vitodens 100-W wall-mounted condensing boiler is the perfect combination of value, quality and Viessmann technology.

The benefits at a glance:

- **Outstanding efficiency** of 95.2 % A.F.U.E. on all models.
- **Lasting performance** with Viessmann-made SA240 316Ti stainless steel Inox-Radial heat exchanger constructed to ASME Section IV and CSA B51.
- **Low-emission** with fully-modulating stainless steel Matrix cylinder burner. Factory calibration eliminates adjustments in the field.
 - < 29 ppm NO_x (at 3% O₂)
 - < 40 ppm CO (at 3% O₂)
- **Control variety** Integrated boiler control interfaces with any level of external control - from room thermostat to outdoor reset and more.
- **Compact, lightweight design** and zero clearance to combustibles make it a great choice for limited-space installations.
- **Extremely quiet operation;** quieter than most refrigerators.
 - < 50 dBA (at 1 meter / 3.3 ft.)
- **Easy installation, service and maintenance** with all pipe connections located at the bottom and serviceable components easily accessible from the front.
- **Multiple venting options**
 - Horizontal or vertical sealed combustion coaxial vent system (factory supplied).
 - Horizontal, vertical or hybrid sealed combustion double-pipe vent system (field supplied).
 - Horizontal or vertical single-wall vent system (field supplied).
- **Suitable for high altitude levels** of up to 10,000 ft. / 3,000 m **without deration.**
- **Built-in automatic frost protection** allows boiler to be shut off for an extended period of time while protecting it against freeze-up.
- **Limited lifetime warranty** in residential applications.

Product Information Cross-Section

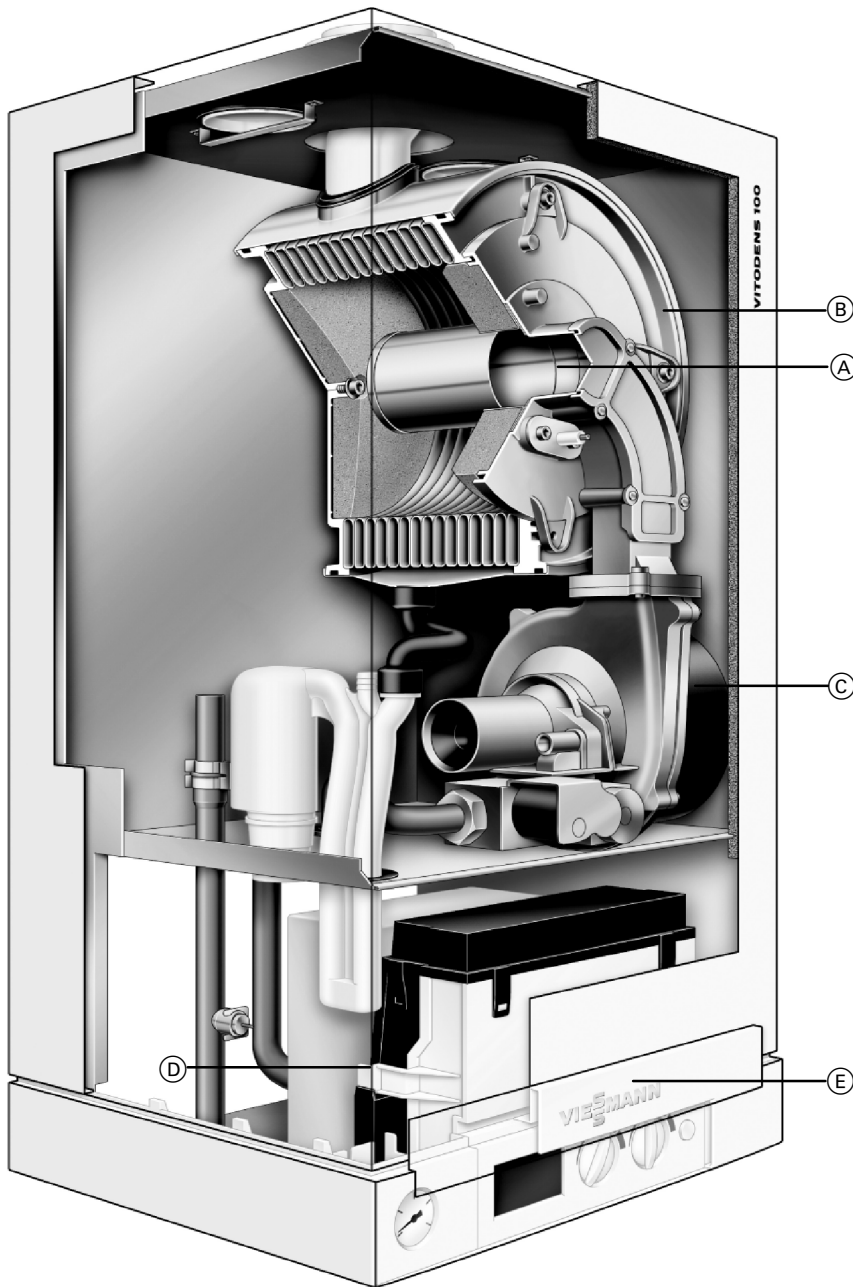

Legend

- Ⓐ Stainless steel MatriX cylinder burner
- Ⓑ Inox-Radial stainless steel heat exchanger
- Ⓒ Burner blower
- Ⓓ Gas and hydronic connections
- Ⓔ Boiler control

Standard Equipment:

Wall-mount boiler and installation fittings c/w 30 psi pressure relief valve, pressure gage, gas shut-off valve, two fill/drain valves, all mounting hardware, outdoor temperature sensor, and LP conversion kit.

Product may not look exactly as illustrated.

Technical Data

Technical Data

Boiler Model		Standard heating boiler	
		Model No.	
		WB1B 26	WB1B 35
Natural gas and LPG			
CSA input	MBH	37-91	37-118
	kW	10.8-26.7	10.8-34.6
CSA output/DOE ^{*1}	MBH	34-83	34-108
heating capacity	kW	9.9-24.3	9.9-31.6
Net I = B = R rating ^{*2}	MBH	72	94
Heat exchanger surface area	ft. ²	10.23	10.23
	m ²	0.86	0.86
Min. gas supply pressure			
Natural gas	"w.c.	4	4
LPG	"w.c.	10	10
Max. gas supply pressure^{*3}			
Natural gas and LPG	"w.c.	14	14
A.F.U.E.	%	95.2	95.2
Weight	lbs	78	78
	kg	34.1	34.1
Shipping weight	lbs	95	95
	kg	43	43
Boiler water content	USG	0.87	0.87
	ltr	3.3	3.3
Boiler max. flow rate ^{*4}	GPM	6.2	6.2
	ltr/h	1400	1400
Max. operating pressure at 210°F / 99°C	psig	45	45
	bar	3	3
Boiler water temperature			
– Adjustable high limit (AHL) range			
– space heating (steady state)		86 to 176 / 30 to 80	
– DHW production (set-point)		172 / 78	
– Fixed high limit (FHL)		210 / 99	
Boiler connections			
Boiler heating supply and return	NPTM (male) "	¾	¾
Pressure relief valve	NPTF (female) "	¾	¾
Drain valve	(male thread)	¾	¾
Dimensions			
Overall depth	inches	14 ¹ / ₈	14 ¹ / ₈
	mm	360	360
Overall width	inches	15 ^¾	15 ^¾
	mm	400	400
Overall height	inches	28 ^½	28 ^½
	mm	725	725

^{*1} Output based on 140°F / 60°C, 120 °F / 49°C system supply/return temperature.

^{*2} Net I = B = R rating based on piping and pick-up allowance of 1.15.

^{*3} If the gas supply pressure exceeds the maximum gas supply pressure value, a separate gas pressure regulator must be installed upstream of the heating system.

^{*4} See "Maximum Flow Rates" on pages 15 to 17 in this manual.

		Standard heating boiler	
Boiler Model	Model No.	WB1B 10-26	WB1B 10-35
Gas supply connection	NPTF "	¾	¾
Flue gas *5			
Temperature (at boiler return temperature of 86°F / 30°C)			
- at rated full load	°F / °C	127 / 53	131 / 55
- at rated partial load	°F / °C	90 / 32	90 / 32
Temperature (at boiler return temperature of 140°F / 60°C)		°F / °C	167 / 75
172 / 78			
Flue gas value			
Mass flow rate (of flue gas)			
- at rated full load	lbs/h	79.2	100.1
	kg/h	36.0	45.5
- at rated partial load	lbs/h	33.0	33.0
	kg/h	15.0	15.0
Available draught	Pa	100	100
	mbar	1.0	1.0
Flue gas temperature sensor limit	°F / °C	230 / 110	230 / 110
Average condensate flow rate *6			
with natural gas			
- T _S /T _R = 122/86°F / 50/30 °C	USG/day	1.95-2.3	2.5-2.8
	ltr/day	8-9	9.4-10.5
Condensate connection *7	hose nozzle		
	Ø in	1	1
Boiler flue gas connection *8	Ø in/mm	2 ³ / ₈ /60	2 ³ / ₈ /60
Combustion air supply connection *8	outer Ø in/mm	4/100	4/100
Noise level (at 1 meter)			
- at full load	(dB)	47	49
- at partial load	(dB)	40	42
High altitude (factory set) *9	ft. / m	0-5,000 / 0-1,500	0-5,000 / 0-1,500

*5 Measured flue gas temperature with a combustion air temperature of 68°F / 20°C.

*6 Based on typical boiler cycles, including partial load conditions.

*7 Requires 1" / 25 mm tubing. See Vitodens 100-W Installation Instructions for details.

*8 For an overview of venting options refer to the appendix starting on page 19. For detailed information refer to the Vitodens Venting System Installation Instructions.

*9 For 5,000 to 10,000 ft / 1,500 to 3,048 m operation, a coding address change is required. Refer to the Installation and Service Instructions for details.

► For information regarding other Viessmann System Technology componentry, please reference documentation of respective product.

Vitodens 100-W

Vitodens 100-W, WB1B 26/35
without piping connections

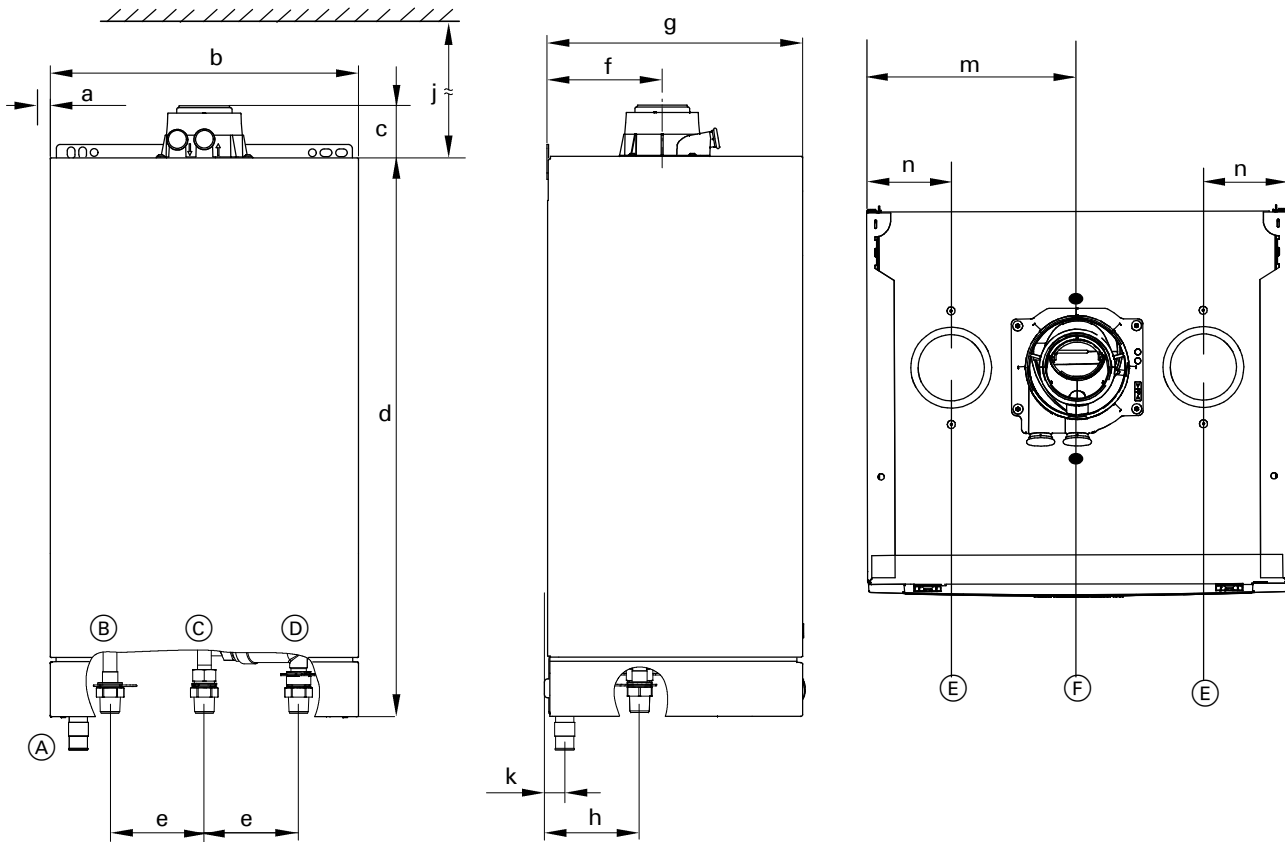

Fig. 1 Front view

Side view

Top view

Connections Vitodens 100-W,
WB1B 10-26, 10-35

Legend

Connections

- (A) Condensate drain, plastic hose
Ø 1" / 25mm
- (B) Boiler water supply, NPT 3/4" (male thread)
- (C) Gas connection, NPT 3/4" (male thread)
- (D) Boiler water return, NPT 3/4" (male thread)
- (E) Combustion air opening for double pipe system
- (F) Combustion air opening for co-axial system

Dimensions

- a See fig. 2 for dimensions
- b 15 3/4" / 400 mm
- c 2 5/8" / 68 mm
- d 28 1/2" / 725 mm
- e 4 7/8" / 123 mm
- f 6 1/8" / 156 mm
- g 14 1/8" / 360 mm
- h 5" / 125 mm
- j 9 7/8" / 250 mm
- k 1 1/4" / 31 mm
- m 7 7/8" / 200 mm
- n 3 1/8" / 80 mm

**Vitodens 100-W, WB1B 26/35
with piping connections**

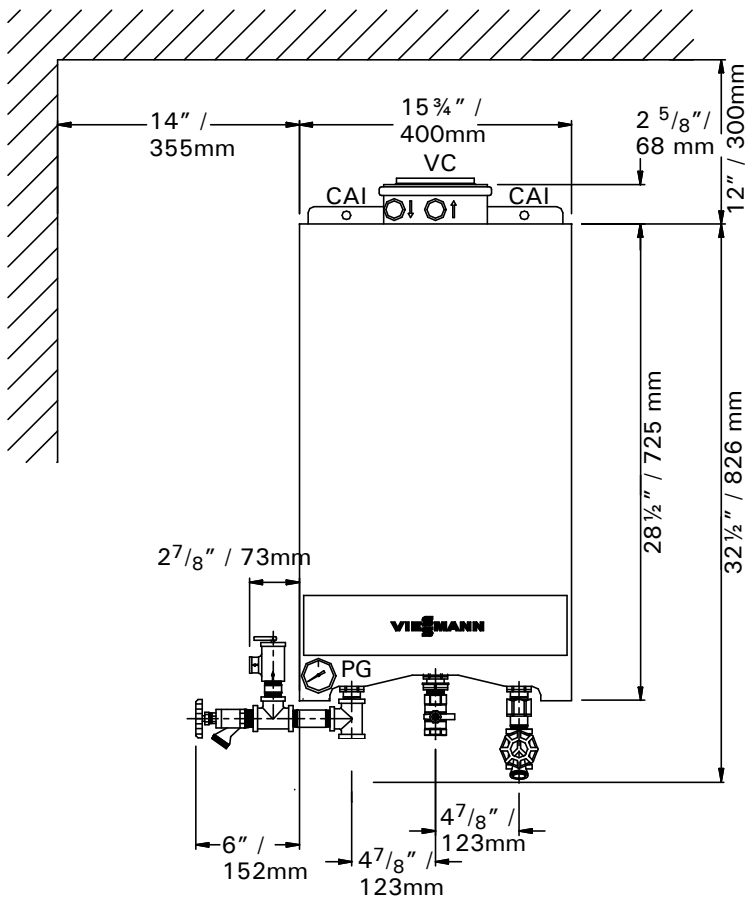

Fig. 2

**Piping connections for Vitodens
100-W, WB1B 10-26 and 10-35
(factory supplied)**

Legend

- BWR Boiler water return, 3/4"
- BWS Boiler water supply, 3/4"
- BD Boiler drain
- BF Boiler fill
- GC Gas connection, 3/4" NPTM (male thread)
- PRV Pressure relief valve
- PG Pressure gage
- VC Venting connection
- CAI Combustion air inlet connection (optional)

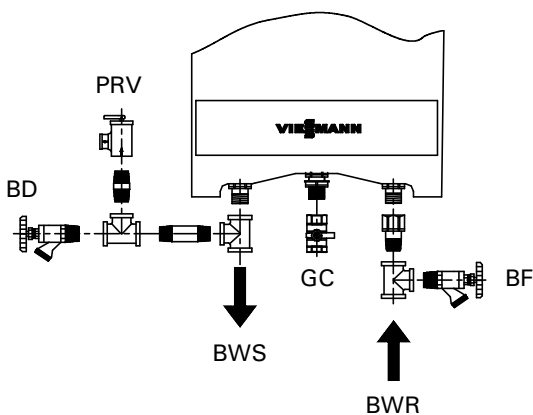

Fig. 3

Recommended Minimum Service Clearances

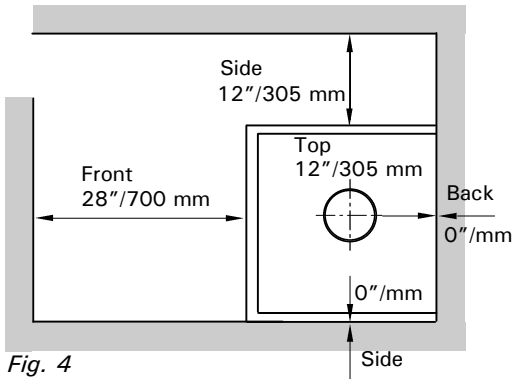

Fig. 4

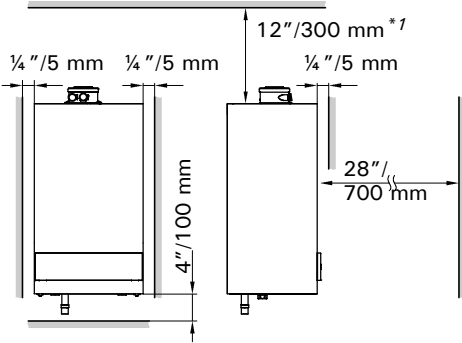

Fig. 5

Minimum Clearances to Combustibles

Top	Front	Rear	Left	Right	Vent pipe ^{*1}
0	0 AL, CL	0	0	0	0

AL = Alcove

CL = Closet

^{*1}Refer to the Installation Instructions of the Vitodens Venting System for details.

Note:

The Vitodens 100-W boiler has passed the zero inches vent clearance to combustibles testing requirements provided by the boiler Harmonized Standard ANSI Z21.13, CSA 4.9.2005 and therefore is listed for zero clearance to combustibles when vented with a single wall special venting system (AL-29-4C material) or UL/ULC-listed CPVC gas vent material. The zero inches vent clearance to combustibles for the Vitodens 100-W boiler supercedes the clearance to combustibles listing that appears on the special venting system label.

Waterside Flow (boiler circuit)

The Vitodens 100-W is designed only for closed loop, forced circulation hot water heating systems.

Pressure drop (primary circuit) of Vitodens 100-W

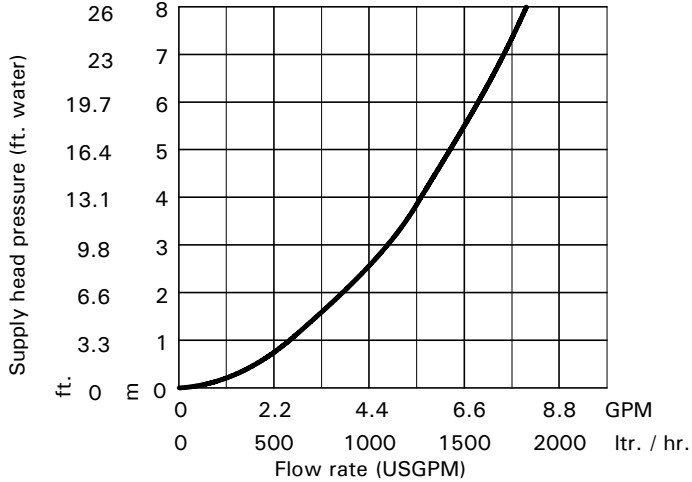

A low-loss header **must** be used when the **system** flow rate exceeds the maximum or falls below the minimum flow rate of the Vitodens 100-W boiler. An alternative method may be used, such as primary secondary piping using closely spaced tees. A low-loss header offers additional benefits not provided by a pair of closely spaced tees. Viessmann strongly recommends and prefers the use of a low-loss header over closely spaced tees.

Please see page 13 for details.

Use standard friction loss method for pipe sizing.

Observe boiler maximum and minimum flow rate limitations. If system flow rate exceeds boiler maximum flow rate (as stated on page 13) or if system flow rate is unknown, Viessmann strongly recommends the installation of a low-loss header. See page 13 for low-loss header information.

Heating Circuit Pumps

Recommended heating pumps with Vitodens 100-W, WB1B 10-26, 10-35:

- Grundfos 15-58 (3-speed)
- Taco OOR
- or equivalent

Refer to the graph above for the proper waterside boiler friction loss calculations.

IMPORTANT

Pump selection must be based on accurate system flow and pressure drop calculations (incl. DHW sizing).

DHW Production/Wall Mounting

Domestic Hot Water Production via DHW Storage Tank

Vitodens 100-W boilers can be used in conjunction with the stand-alone DHW storage tanks offered by Viessmann (a separate DHW controller should be field supplied). All Viessmann DHW storage tanks sold in North America are available in "Vitosilver" finish only.

Size and select the DHW storage tank based on the forecast DHW consumption of the building in question.

For further technical information on DHW storage tanks, see the Vitocell-V Technical Data Manuals.

Wall Mounting Information

The Vitodens 100-W (model WB1B 10-26 and 10-35) comes with a template, which allows you to easily mark the location of the screws for the mounting bracket and the location of the flue gas pipe on the wall (Viessmann coaxial PPS vent system only).

The connection to the heating circuits must be made on site (installation fittings are supplied in the Installation Fittings package supplied with the boiler).

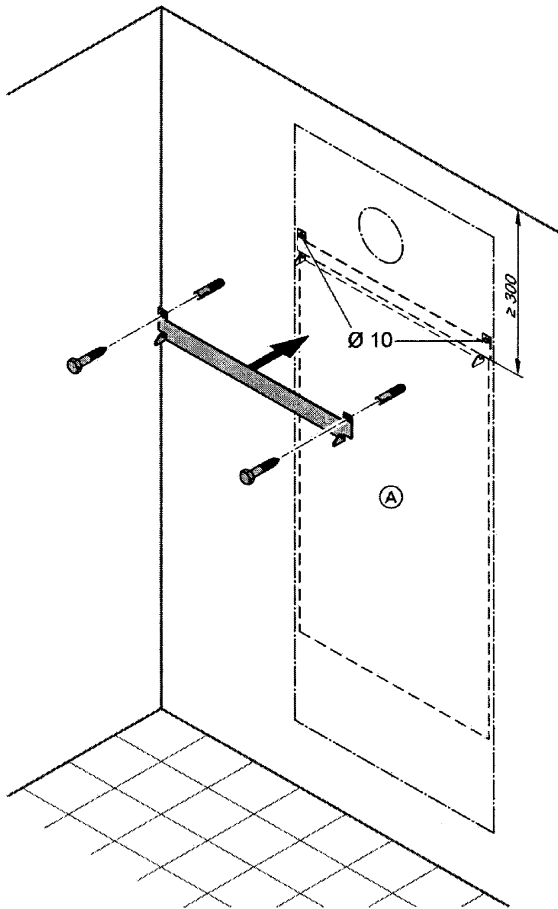

Fig. 6

Legend

(A) Mounting template

Condensate Connection

Install the condensate drain pipe ($\varnothing \frac{7}{8}'' / 22\text{mm}$) with a suitable gradient (min. 2.5%). Discharge condensate from the boiler into the drainage system, either directly or (if required) via a neutralization unit (accessory).

The condensate drain of the Vitodens 100-W boiler is equipped with a built-in siphon trap in order to keep flue gases from being discharged via the condensate drain.

IMPORTANT

Pipe ventilation must take place between the siphon trap and the neutralization unit (if applicable).

Condensate connection for Vitodens 100-W

- model WB1A 8-24, 8-30

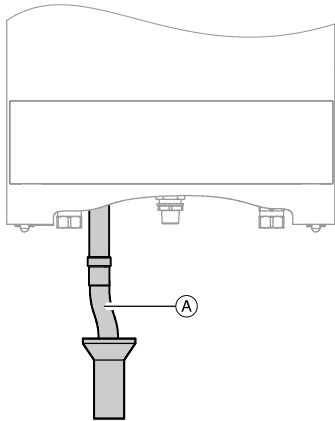

Ⓐ Discharge tubing

Fig. 7

Condensate Drainage and Condensate Neutralization

The condensate formed both in the condensing boiler and in the flue gas pipe must be discharged into the public sewage system in accordance with all applicable local regulations. The condensate produced by a gas-fired heating system has a pH value between 3 and 4.

Some local codes may require the use of a separate neutralization unit to treat the aggressive and corrosive condensate. With a neutralization unit installed, all condensate from the boiler and the flue gas pipe enters into the neutralization unit where it is treated and released into the public sewage system with a safe pH value of above 6.5.

The use of neutralization granulate (performing the neutralizing process) is dependent on the operation of the heating system. To determine the required refill amount, check granulate level several times during the first year of operation. In some cases one granulate fill may last an entire year.

Contact Viessmann to order a neutralization unit for the Vitodens 100-W boiler. See Viessmann Price List for order information.

The condensate discharge outlet to the drainage system connection must be clearly visible. It must be installed with a suitable gradient and provided with a stench trap.

If the condensate outlet of the Vitodens 100-W boiler is lower than the drain, a condensate pump must be used.

Only corrosion-resistant materials may be used for condensate drainage purposes (e.g. braided hose). Do not use galvanized materials or materials containing copper for piping, couplings etc. The condensate drain must have a trap to prevent flue gas leakage.

Please note that other requirements may apply depending on local regulations and/or project-specific details.

It is advisable to contact your local waterworks office (authority responsible for waste water regulations) well before commencing with the installation of the neutralization unit in order to establish details of local regulations that apply.

The following table shows the concentration of (effluent) substances (e.g. heavy metals) contained in the waste water from the Vitodens 100-W condensing boiler.

Condensate (effluent) substances	Values measured in mg/ltr	
	Vitodens 100	
Lead	<	0.01
Cadmium	<	0.005
Chromium	<	0.01
Copper	<	0.01
Nickel	<	0.01
Zinc	<	0.05
Tin	<	0.05

Vitodens 100-W Venting Options

For an overview of venting options refer to the appendix starting on page 19. For detailed information refer to the Vitodens Venting System Installation Instructions.

Electrical Connection

All electrical connections are made to the boiler's integrated power pump module (120 VAC/60 Hz). Use disconnect means and power service switch as per local code requirements.

Control Unit

Function and construction

The control is integrated into the Vitodens 100-W boiler.

- Integrated diagnostic system
- For room temperature-dependent operation, an external control or a room temperature thermostat may be connected
- To control DHW temperature, a separate DHW controller may be connected
- External heat demand
- 0-10 V (field wiring)
- Viessmann outdoor temperature sensor (field wiring)
- Open Therm (field wiring)

The control unit consists of:

- LCD Display
- Selector dial for boiler water temperature adjustment
- Selector dial for service setting
- Temperature adjustable high limit
- Boiler temperature sensor
- Burner fault display
- Burner fault reset
- Pressure gage
- Fuse

Boiler temperature sensor

The boiler temperature sensor is connected to the control unit and built into the boiler.

Frost protection

Frost protection is continuously active. The burner is switched ON when the boiler water temperature reaches 41 °F / 5 °C and is switched OFF again when the boiler water temperature reaches at least 59 °F / 15 °C (but not more than 68 °F / 20 °C).



For details on the control, please refer to the Vitodens 100-W Operating Instructions.

Accessories for the Vitodens 100-W

Neutralization Unit for Single-Boiler Applications
with neutralizing granulate

for Vitodens 100-W, WB1B 10-26, 10-35
Part No. 7134 231

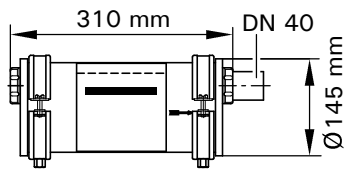

Fig. 8

Low-Loss Header

-Type 80/50
Part No. 7134 791
(max. flow rate 17.6 GPM / 4 m³/h)
-Type 120/80
Part No. 7134 792
(max. flow rate 35.2 GPM / 8 m³/h)

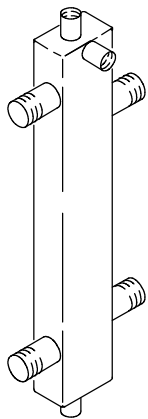

Fig. 9

A low-loss header offers additional benefits not provided by a pair of closely spaced tees. Viessmann strongly recommends and prefers the use of a low-loss header over closely spaced tees. When used in conjunction with the Vitodens 100-W boiler, the low-loss header acts as hydraulic break, decoupling boiler and system circuits from each other (no sensor required). It is recommended to use the low-loss header in applications in which the total system flow rate exceeds the maximum or falls below the minimum flow rate of the Vitodens 100-W boiler. For maximum boiler flow rates, see the table on page 9 in this manual.

Viessmann strongly recommends the use of a low-loss header in cases where the system head and flow rates are unknown.

In addition, the low-loss header helps eliminate air and debris [D] from the heating system. See Fig. 10 and 11 for an illustration of the principle of operation.

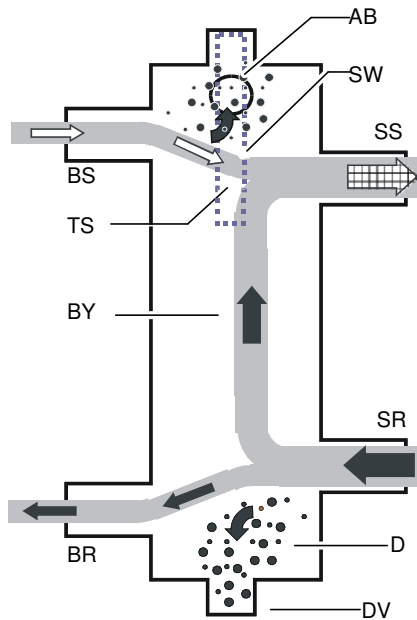

Fig. 10 Low-loss header design

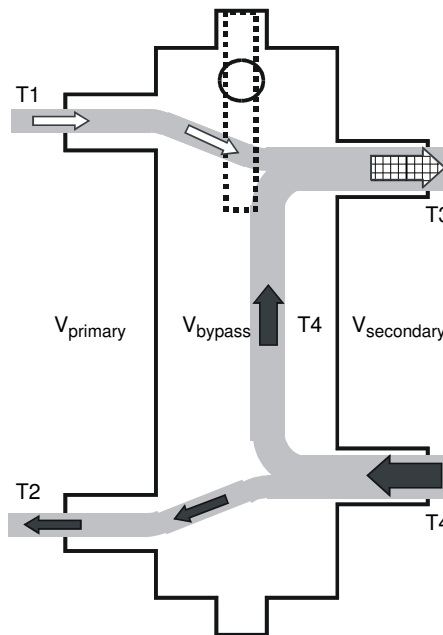

Fig. 11 Principle of Operation

Product does not look exactly as illustrated.

The low-loss header is available in the following sizes. Select the size based on the maximum system flow rate of your application.

Model No.	Max. system flow rate
Type 80/50	17.6 GPM / 4 m ³ /h
Type 120/80	35.2 GPM / 8 m ³ /h

Legend

- AB Air Bleed
- BR Boiler Return
- BS Boiler Supply
- BY Bypass (with laminar flow)
- D Debris and/or air
- DV Drain Valve
- SR System Return
- SS System Supply
- TS Viessmann Temperature Sensor (not used)
- SW Sensor Well

- T1 Boiler supply temperature
- T2 Boiler return temperature
- T3 System supply temperature
- T4 System return temperature
- V_{primary} Boiler circuit flow rate
- V_{secondary} Heating circuit flow rate
- V_{bypass} Bypass flow rate
- Q_{primary} Heat supplied by boiler
- Q_{secondary} Heat consumed by system

$$V_{primary} < V_{secondary}$$

$$T1 > T3$$

$$T2 = T4$$

$$Q_{primary} = Q_{secondary}$$

$$T1 \leq 176^{\circ}F / 80^{\circ}C$$

$$V_{secondary} = V_{primary} + V_{bypass}$$

IMPORTANT

When installing a low-loss header, system mixed supply temperature (T3) must be calculated as follows:

$$T3 = \frac{T1 \times V_{primary} + T4 \times V_{bypass}}{V_{secondary}}$$

Standard Equipment/How the Vitodens 100-W Operates.../ Installation Examples

Standard Equipment

The Vitodens 100-W gas-fired condensing boiler with Inox-Radial heat exchanger surfaces, modulating stainless steel MatriX cylinder gas burner
c/w

- installation fittings with 30 psig pressure relief valve, air vent and pressure gauge
- two fill/drain valves
- all mounting hardware

The boiler comes fully piped and prewired.

Venting material (coaxial) is to be supplied by Viessmann only. Side wall vent installations must include Viessmann protective screen!

Wall mounting componentry

The following wall mounting components are supplied with the Vitodens 100-W boiler:

- Mounting bracket
- Mounting bolts
- Installation fittings
- Screws for mounting bracket on
 - wood studs (2" x 4")
 - metal studs
 - brick/concrete wall

How the Vitodens 100-W boiler operates...

The Vitodens 100-W boiler uses a premix combustion system, which is designed to deliver a certain air-gas mixture to the burner for complete combustion. The gas is injected upstream of the blower. The burner and heat exchanger are part of a forced-draft design. The benefits of forced-draft systems are lower component temperatures, direct air-fuel connection (premix) for improved mixing, and longer service life of the boiler due to mild to moderate ambient conditions.

The MatriX cylinder burner, blower and the combination gas valve are factory calibrated and pre-adjusted. A pneumatic link between combustion air and gas flows guarantees optimal boiler performance at all firing rates. Blower speed is automatically increased or decreased based on heat demand, thereby regulating the amount of combustion air drawn. The pneumatic link between air and gas introduces the required amount of gas for optimal combustion to meet the current heat demand, based on a linear relationship between ΔP air and ΔP gas.

Installation Examples

IMPORTANT

The examples on the following pages depict possible piping layouts of the Vitodens 100-W boiler.

Please note that the following examples are simplified conceptual drawings only! Piping and necessary componentry must be field verified. A low water cut-off (LWCO) must be installed where required by local codes. Proper installation and functionality in the field is the responsibility of the heating contractor.

System Layout 1

Vitodens 100-W, WB1B 10-26, 10-35 with one heating circuit

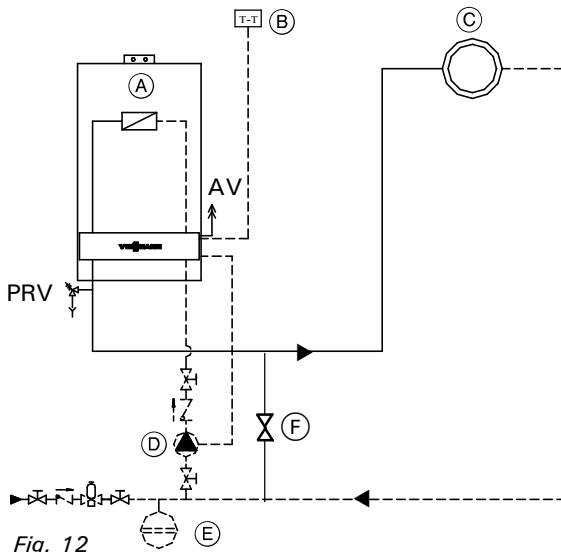

Fig. 12

Legend

AV Air vent
PRV Pressure relief valve

- (A) Vitodens 100-W
- (B) Room thermostat
- (C) Heating circuit
- (D) Heating circuit pump (field supplied)
- (E) Expansion tank
- (F) Pressure Activated By-Pass

* **Please note:**
Heating circuit (C) in the examples should be designed to 30°F to 40°F / 16.7°C to 22.2°C. For lesser delta T design, system layout designer must use one of the examples (3 or 4) on the following pages.

System Layout 1 - Alternate Option

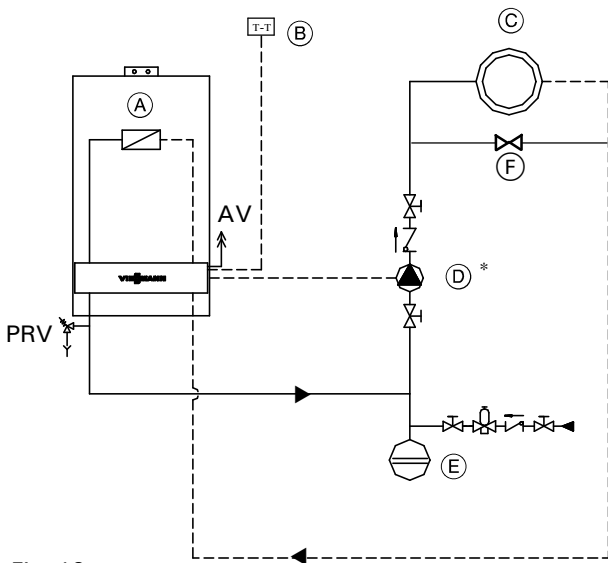

Fig. 13

IMPORTANT

Ensure that a pressure activated by-pass is installed if there are system component(s) in (C) that may isolate the flow to the pump (D).

Please note!

The use of a low-loss header is recommended if the water flow rate is less than 1.7 GPM / 400 ltr/h or more than 6.2 GPM / 1400 ltr/h. The low-loss header is available as accessory part.

Maximum Flow Rates

Model	WB1B	10-26	10-35
Δ t			
Output Btu/h		83,000	108,000
30 °F rise (GPM)		5.5	----
35 °F rise (GPM)		4.7	6.2
40 °F rise (GPM)		4.2	5.4

Installation Examples

System Layout 2

Vitodens 100-W, WB1B 10-26, 10-35 with...

- DHW storage tank
- low-loss header
- one heating circuit

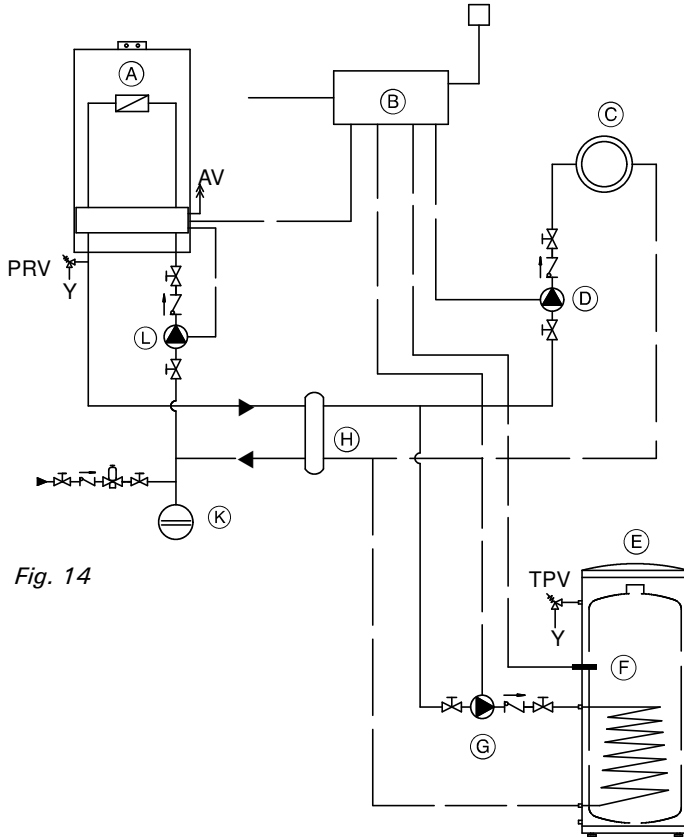

Fig. 14

AV Air vent
 PRV Pressure relief valve
 TPV Temperature and pressure relief valve

- (A) Vitodens 100-W gas-fired condensing boiler
- (B) External boiler/DHW controller (field supplied)
- (C) Heating circuit
- (D) Heating circuit pump (field supplied)
- (E) DHW storage tank
- (F) DHW tank temperature aquastat or sensor
- (G) DHW circulating pump (field supplied)
- (H) Low-loss header
- (K) Expansion tank
- (L) Primary pump (boiler circuit, field supplied) *with low-loss header only*

IMPORTANT

Primary pump (L) must pump into the boiler (as illustrated).

Please note!

The use of a low-loss header is recommended if the water flow rate is less than 1.7 GPM / 400 ltr/h or more than 6.2 GPM / 1400 ltr/h.

The low-loss header is available as accessory part.

Maximum Flow Rates

Model	WB1B	10-26	10-35
Δt			
Output Btu/h		83,000	108,000
30°F rise (GPM)		5.5	----
35°F rise (GPM)		4.7	6.2
40°F rise (GPM)		4.2	5.4

IMPORTANT

DHW supply and return piping between boiler DHW connections and the Viessmann DHW tank connections, shall be a minimum of 1" nominal pipe diameter (irrespective of the 3/4" DHW connection outlet sizes provided on the boiler and the DHW tank). This ensures that the head of the pump is fully utilized to overcome the resistance of the DHW heat exchanger coil and to provide sufficient water flow to the boiler heat exchanger. In non-Viessmann DHW tank applications, perform, in addition to the above, accurate calculations for DHW tank coil pressure drop versus boiler pump head to ensure sufficient water flow to the boiler heat exchanger. Failure to heed the above instructions may cause boiler short-cycling and inadequate DHW supply.

System Layout 3

Vitodens 100-W, WB1B 10-26, 10-35 with DHW storage tank and one heating circuit

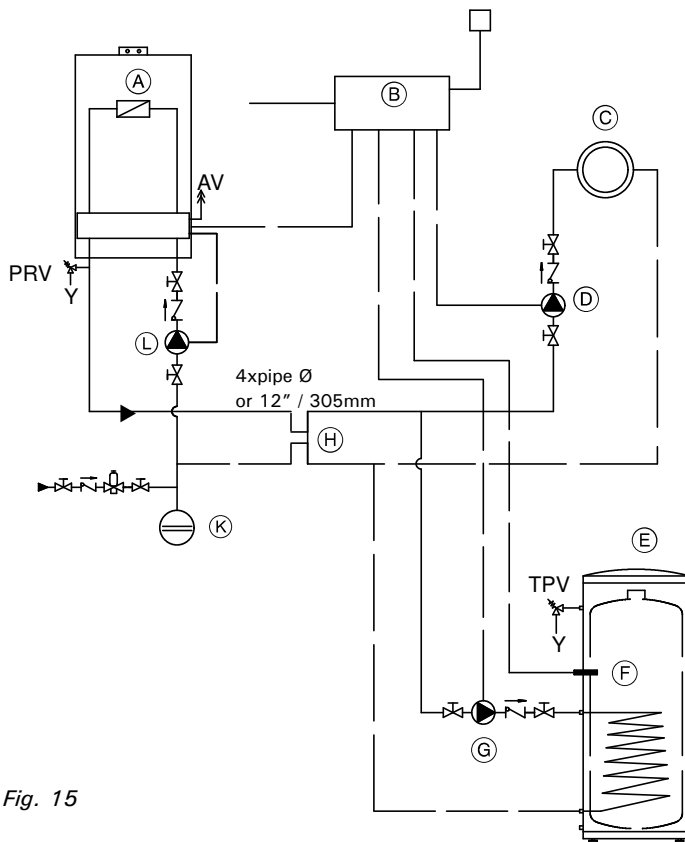

Fig. 15

AV Air vent
 PRV Pressure relief valve
 TPV Temperature and pressure relief valve

- (A) Vitodens 100-W gas-fired condensing boiler
- (B) External boiler/DHW controller (field supplied)
- (C) Heating circuit
- (D) Heating circuit pump (field supplied)
- (E) DHW storage tank
- (F) DHW tank temperature aquastat or sensor
- (G) DHW circulating pump (field supplied)
- (H) Closely spaced tees, 4xpipe Ø or 12" / 305mm*
- (K) Expansion tank
- (L) Primary pump (boiler circuit, field supplied) *with low-loss header only*

* A low-loss header offers additional benefits not provided by a pair of closely spaced tees. Viessmann strongly recommends and prefers the use of a low-loss header over closely spaced tees.

Please see page 13 for details.

IMPORTANT

Primary pump (L) must pump into the boiler (as illustrated).

Please note!

The use of a low-loss header is recommended if the water flow rate is less than 1.7 GPM / 400 ltr/h or more than 6.2 GPM / 1400 ltr/h.

The low-loss header is available as an accessory part.

Maximum Flow Rates

Model	WB1B	10-26	10-35
Δ t			
Output Btu/h		83,000	108,000
30 °F rise (GPM)		5.5	----
35 °F rise (GPM)		4.7	6.2
40 °F rise (GPM)		4.2	5.4

IMPORTANT

DHW supply and return piping between boiler DHW connections and the Viessmann DHW tank connections, shall be a minimum of 1" nominal pipe diameter (irrespective of the 3/4" DHW connection outlet sizes provided on the boiler and the DHW tank). This ensures that the head of the pump is fully utilized to overcome the resistance of the DHW heat exchanger coil and to provide sufficient water flow to the boiler heat exchanger. In non-Viessmann DHW tank applications, perform, in addition to the above, accurate calculations for DHW tank coil pressure drop versus boiler pump head to ensure sufficient water flow to the boiler heat exchanger. Failure to heed the above instructions may cause boiler short-cycling and inadequate DHW supply.

System Design Considerations

IN THE COMMONWEALTH OF MASSACHUSETTS...

-this product shall be installed by a licensed plumber or gas fitter.

-the flexible connector (if used) may not exceed 36".

-any level type shutoff used must be of tee handle type.

Boiler location

As a direct vent appliance, the Vitodens 100-W may be installed for room air independent operation (sealed combustion) **regardless** of size and ventilation method of the room in which it is located. The Vitodens 100-W may be installed, for example, in the main living area of a house, in non-ventilated utility rooms, cupboards, closets and alcoves with no clearance required from combustible materials, as well as in attics with a direct outlet for the flue gas/fresh air system. Follow all local and national codes.

Flue gas system

Viessmann coaxial PPS (Polypropylene - flame retardant) concentric flue gas/fresh air systems and two-pipe stainless steel/CPVC systems for room air independent operation (sealed combustion) and side wall venting are tested to ANSI Z21.13 - CSA 4.9 - 2007 standards and are certified together with the Vitodens 100-W boiler as a constructional unit. The Vitodens 100-W boiler may also be vented vertically or horizontally, using a metallic AL29-4C® special stainless steel, or non-metallic CPVC single-wall, room air dependent venting system (UL/ULC listed for category IV). For a more detailed description of the direct vent and single-wall vent system, please refer to the Vitodens Venting System Installation Instructions.

Flue gas temperature protection

Viessmann coaxial PPS (Polypropylene - flame retardant) flue pipes used for the Vitodens 100-W are rated for max. flue gas temperatures of up to 248 °F/120 °C. Flue gas temperature protection is also included although the maximum permissible flue gas temperature will not be exceeded in any operating condition or in the event of malfunctioning.

Low water cut-off

A low water cut-off may be required by local codes. If the boiler is installed above the radiation level, a low water cut-off device of approved type must be installed in all instances. An approved low water cut-off device that meets government and local regulations must be provided by the heating contractor. Do not install an isolation valve between the boiler and the low water cut-off. The Vitodens 100-W boiler has a built-in flow switch, which may be accepted by local codes in lieu of a low water cut-off.

System layout

- The max. boiler water temperature for ...
 - space heating is 180°F / 82°C.
 - DHW production is 172°F / 78°C.To minimize distribution losses, Viessmann recommends that the heating and domestic hot water systems be based on a maximum boiler supply temperature of 158 °F/70 °C.
- Due to the low return temperatures required for gas condensing, avoid the use of mixing valves in the heating circuit whenever possible. If mixing valves are required, e.g. for multi-circuit systems or underfloor heating systems, only 3-way mixing valves may be used.
Do not use 4-way mixing valves in a system with condensing boilers.

Water connections

Vitodens 100-W boilers can be used in any fully pumped hot water heating system. Minimum system pressure is 0.8 bar/12 psig.

Chemical corrosion protection products

Corrosion does not typically occur in sealed heating systems which have been correctly installed and are correctly operated. Many manufacturers of plastic pipes recommend the use of chemical additives. In this case, only commercially available corrosion protection products that have been approved for boilers with domestic hot water heating via single-wall heat exchangers (instantaneous plate heat exchangers or DHW tanks) may be used.

Underfloor heating systems

For underfloor heating systems Viessmann recommends the use of plastic tubing with an oxygen diffusion barrier in order to prevent the diffusion of oxygen through tubing. If plastic tubing without an oxygen diffusion barrier is used in underfloor heating systems, Viessmann recommends that such systems be separated from the boiler with a heat exchanger.

Oxygen diffusion barrier underfloor tubing

The boiler warranty does not cover leaks resulting from corrosion caused by the use of underfloor plastic tubing without an oxygen diffusion barrier. Such systems must have the non-oxygen diffusion barrier tubing separated from the boiler with a heat exchanger. Viessmann recommends the use of underfloor plastic tubing with an oxygen diffusion barrier.

Water quality

Treatment for boiler feed water should be considered in areas of known problems, such as where a high mineral content and hardness exist. In areas where freezing might occur, an antifreeze may be added to the system water to protect the system. Please adhere to the specifications given by the antifreeze manufacturer. Do not use automotive silicate based antifreeze. Please observe that an antifreeze/water mixture may require a backflow preventer within the automatic water feed and influence components such as diaphragm expansion tanks, radiation, etc. Maximum antifreeze content is 50% for the Vitodens 100-W boiler. Do **not** use antifreeze other than specifically made for hot water heating systems. The system may also contain components which might be negatively affected by antifreeze. Check total system frequently when filled with antifreeze. Advise system operator/ultimate owner that system is filled with a glycol mix. The heating contractor must provide a MSDS (Material Safety Data Sheet) for the antifreeze used to the system operator/ultimate owner.

Warranty

Our warranty does not cover damages resulting from the following:

- installation or service by unqualified and unlicensed personnel.
- attempting to perform any repair work on the boiler other than that mentioned in the boiler literature.
- tampering with or attempting to readjust the factory settings of the combination gas valve
- leaks resulting from corrosion caused by the use of underfloor plastic tubing without an oxygen diffusion barrier.

For detailed warranty information, please read warranty sheet supplied with product.

Vitodens 100-W Venting Alternatives

Venting Alternatives	Vent System Diameter								Type
	Viessmann Coaxial PPs Vent ¹			Stainless Steel Vent ²		CPVC Vent ³			
Max. Equivalent Length (EqL)	60/100	80/125	100/150	3"	4"	2"	3"	4"	Diameter
Horizontally Vented EqL	82 / 25	98 / 30	118 / 36	164 / 50	200 / 61	86 / 26	164 / 50	200 / 61	ft. / m
Vertically Vented EqL	82 / 25	98 / 30	118 / 36	164 / 50	200 / 61	86 / 26	164 / 50	200 / 61	ft. / m
See Page(s)	20-21			22-23		24-25			Page
Horizontal Intake / Vertically Vented EqL	—	—	—	164 / 50	200 / 61	—	164 / 50	200 / 61	ft. / m
See Page(s)				26		26			Page
Select vent material based on vent configuration, preferred material, and necessary maximum equivalent length. Always follow Viessmann venting installation instructions. - Do not common vent Vitodens 100-W with any other appliance. - Layouts on the following pages are for illustrative purposes only . - Do not use Price List for installation purposes. This is not a design tool.									

¹ Sealed combustion, coaxial vent material to be supplied by Viessmann **only**.

² Stainless steel vent material **must** be ULC/UL listed, stainless steel AL29-4C® for Category IV boilers.

Suggested sources: Flexmaster Canada Ltd. / Z-Flex (US) Inc., Heat-fab, ProTech Systems Inc., or Security Chimneys Int'l.

³ CPVC vent material **must** be ULC/UL listed, for Category IV boilers. Suggested source: IPEX Inc.

► Boiler standard working pressure: 30 psig; maximum: 45 psig. For 45 psig, order optional PRV 9549 944.

► Do **not** include first 90° elbow in equivalent vent length calculations (this applies to all vent materials).

Standard Equipment:

Wall-mount boiler and installation fittings c/w 30 psig pressure relief valve, pressure gage, gas shut-off valve, two fill/drain valves, all mounting hardware, outdoor temperature sensor, and LP conversion kit.

Appendix

Coaxial PPs Vent System

Vent System ¹	Vent System Diameter			Diameter	
	60/100	80/125	100/150		
Horizontally Vented	Maximum Equivalent Length (EqL)	82 / 25	98 / 30	118 / 36	ft. / m
Room Air Independent Operation 	Basic Horizontal Vent Kit Venting pieces can be ordered individually, or as a convenient kit using the Order No. to the right; Basic Vent Kit includes one of each of the items numbered ② to ⑤, and two Mounting Clips ⑥.	7424 119	—	—	Order No.
	① Boiler Vent Pipe Adaptor 60/100	included with boiler			
	Adaptor, coaxial 60/100 to 80/125 (not shown)	—	7424 112	—	Order No.
	Adaptor, coaxial 60/100 to 100/150 (not shown)	—	—	7424 113	Order No.
	② 90° Elbow EqL = 1.6ft. / 0.5m	7424 094	7424 095	7424 096	Order No.
	③ Straight Pipe ² 3.3ft. / 1m	7424 091	7424 092	7424 093	Order No.
	④ Vent Termination 2.6ft. / 0.8m	7424 100	7424 101	7424 102	Order No.
	⑤ Protective Screen ¹	7134 237			Order No.
	⑥ Mounting Clip ² (each)	7424 109	7424 110	7424 111	Order No.
	Other Available Vent Pieces not shown in illustration above	Sliding Coupling 1.25ft. / 0.4m	7424 106	7424 107	7424 108
Straight Pipe ² 1.6ft. / 0.5m		7424 088	7424 089	7424 090	Order No.
45° Elbow (Set of 2) EqL = 1.0ft. / 0.3m		7424 097	7424098	7424 099	Order No.

¹ PPs coaxial vent material **must** be ULC S-636 certified for Category IV boilers. Do **not** mix non-ULC S-636 with ULC S-636 venting. Side wall venting installation **must** include Viessmann Protective Screen!

² Order 1 Mounting Clip for **each** straight length of vent pipe installed.

▶ Do **not** include first 90° elbow in equivalent vent length calculations (this applies to all vent materials).

▶ A **maximum** of 5 elbows may be installed in the vent system; do **not** exceed maximum equivalent vent length.

▶ Always follow Viessmann venting installation instructions 5368 815.

Coaxial PPs Vent System (continued)

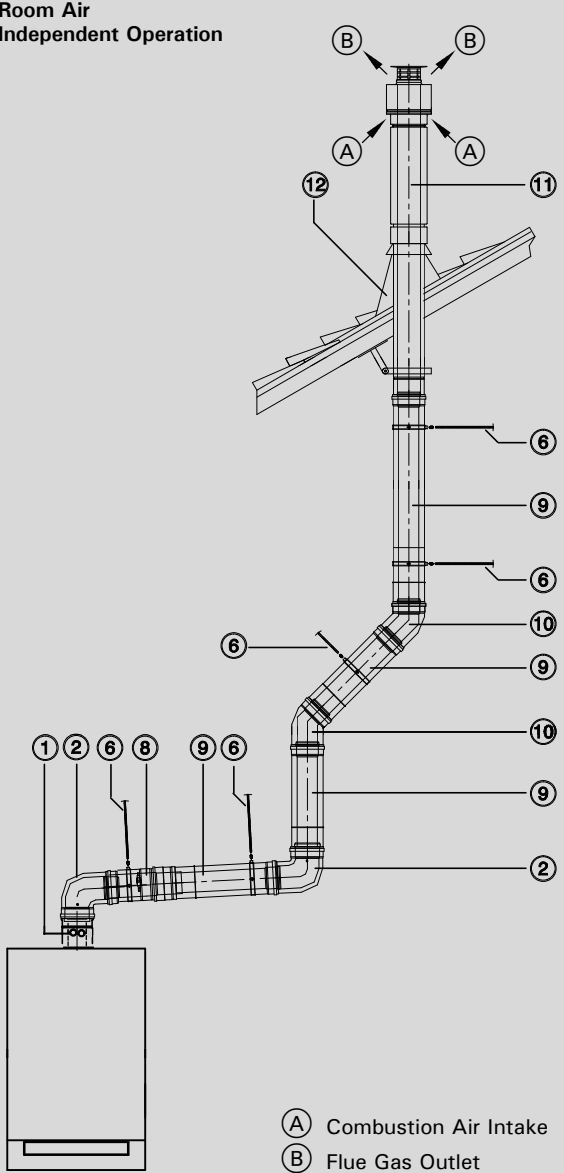
Vent System ¹	Vent System Diameter			Diameter	
	60/100	80/125	100/150		
Vertically Vented	Maximum Equivalent Length (EqL)	82 / 25	98 / 30	118 / 36	ft. / m
Room Air Independent Operation  <p>(A) Combustion Air Intake (B) Flue Gas Outlet</p>	① Boiler Vent Pipe Adaptor 60/100	included with boiler			
	Adaptor, coaxial 60/100 to 80/125 (not shown)	—	7424 112	—	Order No.
	Adaptor, coaxial 60/100 to 100/150 (not shown)	—	—	7424 113	Order No.
	② 90° Elbow EqL = 1.6ft. / 0.5m	7424 094	7424 095	7424 096	Order No.
	⑥ Mounting Clip ² (each)	7424 109	7424 110	7424 111	Order No.
	⑧ Sliding Coupling 1.25ft. / 0.4m	7424 106	7424 107	7424 108	Order No.
	⑨ Straight Pipe ² 1.6ft. / 0.5m	7424 088	7424 089	7424 090	Order No.
	Straight Pipe ² 3.3ft. / 1m	7424 091	7424 092	7424 093	Order No.
	⑩ 45° Elbow (Set of 2) EqL = 1ft. / 0.3m	7424 097	7424 098	7424 099	Order No.
	⑪ Vent Termination 3.9ft. / 1.2m	7424 103	7424 104	7424 105	Order No.
	⑫ Roof Flashing and Storm Collar (B-Vent material or better)	field supplied			

5369 277 v1.5

¹ PPs coaxial vent material **must** be ULC S-636 certified for Category IV boilers. Do **not** mix non-ULC S-636 with ULC S-636 venting.

² Order 1 Mounting Clip for **each** straight length of vent pipe installed.

▶ Do **not** include first 90° elbow in equivalent vent length calculations (this applies to all vent materials).

▶ A **maximum** of 5 elbows may be installed in the vent system; do **not** exceed maximum equivalent vent length.

▶ Always follow Viessmann venting installation instructions 5368 815.

Appendix

Stainless Steel Vent System

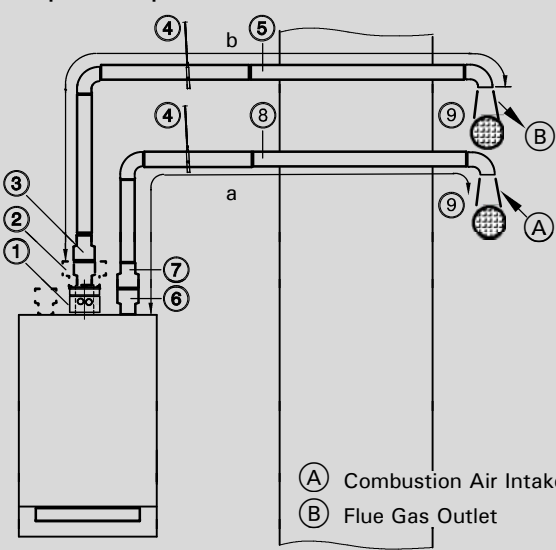
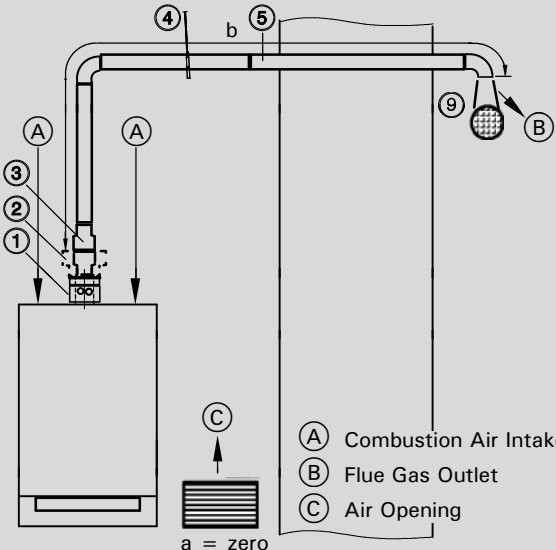
Vent System ¹	Vent System Diameter		Diameter
	3"	4"	
Horizontally Vented	Maximum Equivalent Length (EqL)	$a + b \leq$	164 / 50 200 / 61 ft. / m
Room Air Independent Operation  <p>(A) Combustion Air Intake (B) Flue Gas Outlet</p>	① Boiler Vent Adaptor	included with boiler	
	② Adaptor, for stainless steel 60/100 to 80/125 (outer shell removed)	7424 112	Order No.
	③ Adaptor(s), stainless steel 80mm to 3" 3" to 4" (not shown)	field supplied	field supplied and field supplied
	④ Venting Support ²	field supplied	
	⑤ ULC/UL listed Stainless Steel Vent Material ¹ for EqL calculations, use: ■ 45° Elbow EqL = 2ft. / 0.6m ■ 90° Elbow EqL = 3ft. / 0.9m	field supplied	
	⑥ Adaptor(s), CPVC 60mm to 2"	7134 769	Order No.
	⑦ 2" to 3" or 2" to 4"	field supplied	
	⑧ Combustion Air Intake Vent Material Allowable materials: see note below ³	field supplied	
	⑨ Bird Screen c/w Termination for stainless steel	field supplied	
Room Air Dependent Operation  <p>(A) Combustion Air Intake (B) Flue Gas Outlet (C) Air Opening a = zero</p>	① Boiler Vent Adaptor	included with boiler	
	② Adaptor, for stainless steel 60/100 to 80/125 (outer shell removed)	7424 112	Order No.
	③ Adaptor(s), stainless steel 80mm to 3" 3" to 4" (not shown)	field supplied	field supplied and field supplied
	④ Venting Support ²	field supplied	
	⑤ ULC/UL listed Stainless Steel Vent Material ¹ for EqL calculations, use: ■ 45° Elbow EqL = 2ft. / 0.6m ■ 90° Elbow EqL = 3ft. / 0.9m	field supplied	
	⑨ Bird Screen c/w Termination for stainless steel	field supplied	

¹ Stainless steel vent material **must** be ULC/UL listed, stainless steel AL29-4C® for Category IV boilers. Suggested sources: Flexmaster Canada Ltd. / Z-Flex (US) Inc., Heat-fab, ProTech Systems Inc., or Security Chimneys Int'l.
² Boiler cannot support weight of vent system. Support venting as prescribed in vent manufacturer's installation instructions.
³ Combustion air supply pipe may be made of the following materials: ABS, CPVC, PVC, or stainless steel.
 ▶ Do **not** include first 90° elbow in equivalent vent length calculations (this applies to all vent materials).
 ▶ A **maximum** of 5 x 90° elbows may be installed in the air intake and flue outlet combined; do **not** exceed maximum equivalent vent length.
 ▶ Always follow Viessmann venting installation instructions 5368 815.

Stainless Steel Vent System (continued)

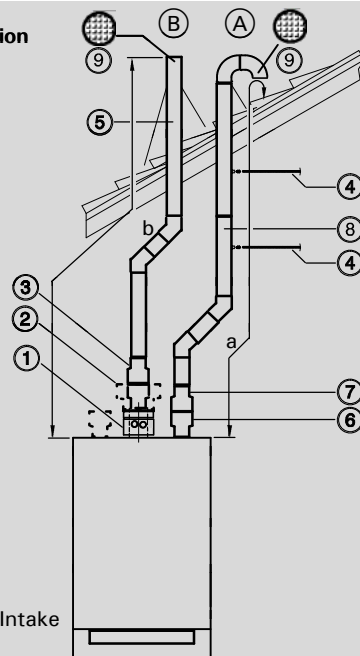
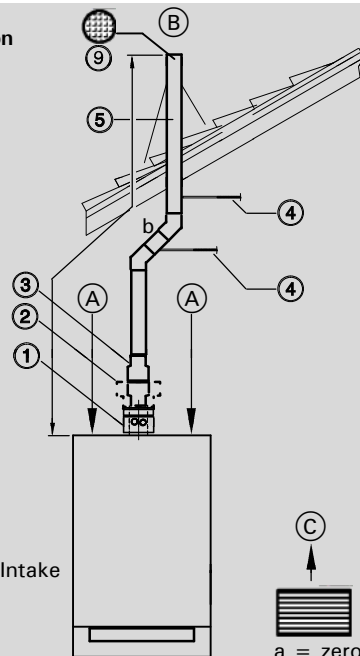
Vent System ¹	Vent System Diameter			Diameter
		3"	4"	
Vertically Vented	Maximum Equivalent Length (EqL)	a + b ≤ 164 / 50	200 / 61	ft. / m
Room Air Independent Operation  <p> (A) Combustion Air Intake (B) Flue Gas Outlet </p>	① Boiler Vent Adaptor	included with boiler		
	② Adaptor, for stainless steel 60/100 to 80/125 (outer shell removed)	7424 112		Order No.
	③ Adaptor(s), stainless steel 80mm to 3"	field supplied	field supplied	and field supplied
	3" to 4" (not shown)	—		
	④ Venting Support ²	field supplied		
	⑤ ULC/UL listed Stainless Steel Vent Material ¹ for EqL calculations, use: ■ 45° Elbow EqL = 2ft. / 0.6m ■ 90° Elbow EqL = 3ft. / 0.9m	field supplied		
	⑥ Adaptor(s), CPVC 60mm to 2"	7134 769		Order No.
	⑦ 2" to 3" or 2" to 4"	field supplied		
	⑧ Combustion Air Intake Vent Material ³	field supplied		
	⑨ Bird Screen c/w Termination	field supplied		
Room Air Dependent Operation  <p> (A) Combustion Air Intake (B) Flue Gas Outlet (C) Air Opening a = zero </p>	① Boiler Vent Adaptor	included with boiler		
	② Adaptor, for stainless steel 60/100 to 80/125 (outer shell removed)	7424 112		Order No.
	③ Adaptor(s), stainless steel 80mm to 3"	field supplied	field supplied	and field supplied
	3" to 4" (not shown)	—		
	④ Venting Support ²	field supplied		
	⑤ ULC/UL listed Stainless Steel Vent Material ¹ for EqL calculations, use: ■ 45° Elbow EqL = 2ft. / 0.6m ■ 90° Elbow EqL = 3ft. / 0.9m	field supplied		
	⑨ Bird Screen c/w Termination for stainless steel	field supplied		

¹ Stainless steel vent material **must** be ULC/UL listed, stainless steel AL29-4C® for Category IV boilers.

Suggested sources: Flexmaster Canada Ltd. / Z-Flex (US) Inc., Heat-fab, ProTech Systems Inc., or Security Chimneys Int'l.

² Boiler cannot support weight of vent system. Support venting as prescribed in vent manufacturer's installation instructions.

³ Combustion air supply pipe may be made of the following materials: ABS, CPVC, PVC, or stainless steel.

▶ Do **not** include first 90° elbow in equivalent vent length calculations (this applies to all vent materials).

▶ A **maximum** of 5 x 90° elbows may be installed in the air intake and flue outlet combined; do **not** exceed maximum equivalent vent length.

▶ Always follow Viessmann venting installation instructions 5368 815.

IMPORTANT :
Do not use any DWV plumbing pipes to vent this boiler.

CPVC Vent System

Vent System ¹	Vent System Diameter			Diameter	
	2"	3"	4"		
Horizontally Vented	Maximum Equivalent Length (EqL) $a + b \leq$	86 / 26	164 / 50	200 / 61	ft. / m
Room Air Independent Operation 	① Boiler Vent Adaptor	included with boiler			
	② Adaptor(s), CPVC 60mm to 2"	7134 769			Order No.
	③ Adaptor(s), CPVC 2" to 3" 3" to 4" (not shown)	—	field supplied	field supplied and field supplied	
	④ Venting Support ²	field supplied			
	⑤ ULC/UL listed CPVC Vent Material ¹ for EqL calculations, use: ■ 45° Elbow EqL = 3ft. / 0.9m ■ 90° Elbow EqL = 5ft. / 1.5m	field supplied			
	⑥ Adaptor(s), CPVC 60mm to 2"	7134 769			Order No.
	⑦ 2" to 3" or 2" to 4"	field supplied			
	⑧ Combustion Air Intake Vent Material Allowable materials: see note below ³	field supplied			
	⑨ Bird Screen (Set of 2) for CPVC	7134 780	7134 781	7134 782	Order No.
Room Air Dependent Operation 	① Boiler Vent Adaptor	included with boiler			
	② Adaptor(s), CPVC 60mm to 2"	7134 769			Order No.
	③ Adaptor(s), CPVC 2" to 3" 3" to 4" (not shown)	—	field supplied	field supplied and field supplied	
	④ Venting Support ²	field supplied			
	⑤ ULC/UL listed CPVC Vent Material ¹ for EqL calculations, use: ■ 45° Elbow EqL = 3ft. / 0.9m ■ 90° Elbow EqL = 5ft. / 1.5m	field supplied			
	⑨ Bird Screen (Set of 2) for CPVC	7134 780	7134 781	7134 782	Order No.

¹ CPVC vent material **must** be ULC/UL listed, for Category IV boilers. Suggested source: IPEX Inc.
² Boiler cannot support weight of vent system. Support venting as prescribed in vent manufacturer's installation instructions.
³ Combustion air supply pipe may be made of the following materials: ABS, CPVC, PVC, or stainless steel.
 ▶ Do **not** include first 90° elbow in equivalent vent length calculations (this applies to all vent materials).
 ▶ A **maximum** of 5 x 90° elbows may be installed in the air intake and flue outlet combined; do **not** exceed maximum equivalent vent length.
 ▶ Always follow Viessmann venting installation instructions 5368 815.

IMPORTANT :
Do not use any DWV plumbing pipes to vent this boiler.

CPVC Vent System (continued)

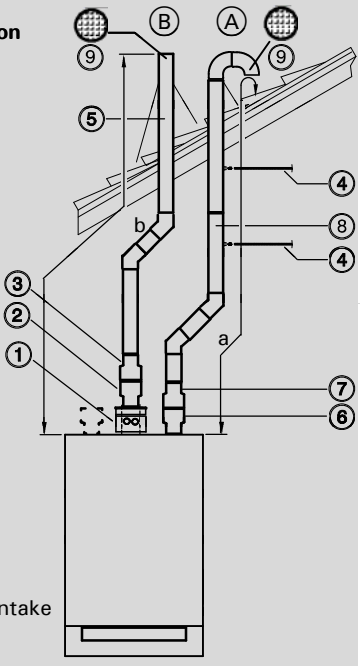
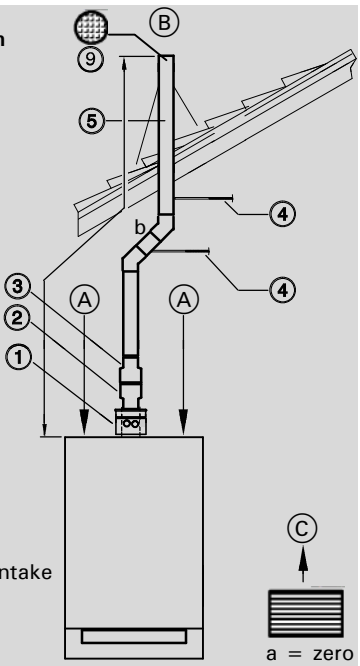
Vent System ¹	Vent System Diameter			Diameter	
	2"	3"	4"		
Vertically Vented	Maximum Equivalent Length (EqL) $a + b \leq$	86 / 26	164 / 50	200 / 61	ft. / m
Room Air Independent Operation  <p> (A) Combustion Air Intake (B) Flue Gas Outlet </p>	① Boiler Vent Adaptor	included with boiler			
	② Adaptor(s), CPVC 60mm to 2"	7134 769			Order No.
	③ Adaptor(s), CPVC 2" to 3"	—	field supplied	field supplied	
	3" to 4" (not shown)	—	—	field supplied	
	④ Venting Support ²	field supplied			
	⑤ ULC/UL listed CPVC Vent Material ¹ for EqL calculations, use: ■ 45° Elbow EqL = 3ft. / 0.9m ■ 90° Elbow EqL = 5ft. / 1.5m	field supplied			
	⑥ Adaptor(s), CPVC 60mm to 2"	7134 769			Order No.
	⑦ 2" to 3" or 2" to 4"	field supplied			
	⑧ Combustion Air Intake Vent Material Allowable materials: see note below ³	field supplied			
	⑨ Bird Screen (Set of 2) for CPVC	7134 780	7134 781	7134 782	Order No.
Room Air Dependent Operation  <p> (A) Combustion Air Intake (B) Flue Gas Outlet (C) Air Opening a = zero </p>	① Boiler Vent Adaptor	included with boiler			
	② Adaptor(s), CPVC 60mm to 2"	7134 769			Order No.
	③ Adaptor(s), CPVC 2" to 3"	—	field supplied	field supplied	
	3" to 4" (not shown)	—	—	field supplied	
	④ Venting Support ²	field supplied			
	⑤ ULC/UL listed CPVC Vent Material ¹ for EqL calculations, use: ■ 45° Elbow EqL = 3ft. / 0.9m ■ 90° Elbow EqL = 5ft. / 1.5m	field supplied			
	⑨ Bird Screen (Set of 2) for CPVC	7134 780	7134 781	7134 782	Order No.

5369 277 v1.5

¹ CPVC vent material **must** be ULC/UL listed, for Category IV boilers. Suggested source: IPEX Inc.

² Boiler cannot support weight of vent system. Support venting as prescribed in vent manufacturer's installation instructions.

³ Combustion air supply pipe may be made of the following materials: ABS, CPVC, PVC, or stainless steel.

▶ Do **not** include first 90° elbow in equivalent vent length calculations (this applies to all vent materials).

▶ A **maximum** of 5 x 90° elbows may be installed in the air intake and flue outlet combined; do **not** exceed maximum equivalent vent length.

▶ Always follow Viessmann venting installation instructions 5368 815.

IMPORTANT :
Do not use any DWV plumbing pipes to vent this boiler.

CPVC or Stainless Steel Vent System

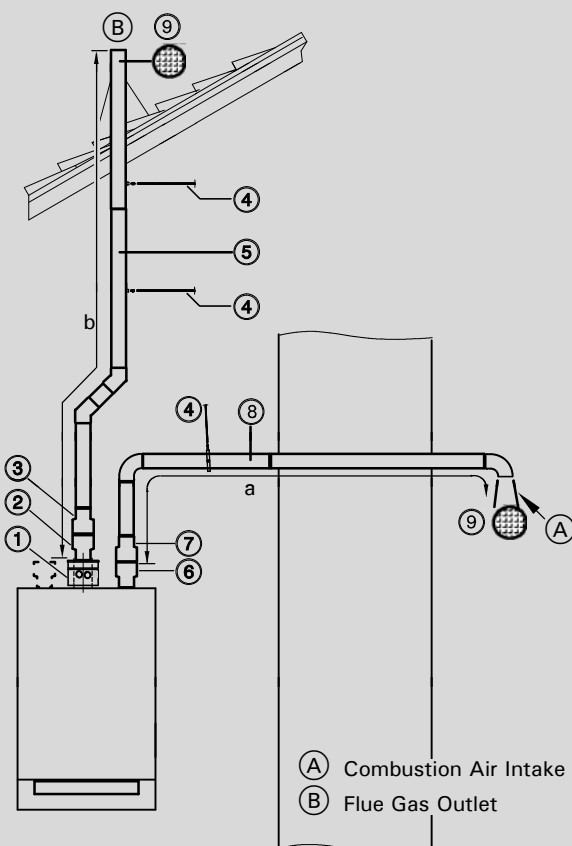
Vent System ¹	Vent System Diameter			Diameter	
	2"	3"	4"		
Hybrid Vent System Horizontal Intake / Vertically Vented	Maximum Equivalent Length (EqL) $a + b \leq$	86 / 26	164 / 50	200 / 61	ft. / m
Room Air Independent Operation  <p>(A) Combustion Air Intake (B) Flue Gas Outlet</p>	① Boiler Vent Adaptor	included with boiler			
	② Adaptor , for stainless steel 60/100 to 80/125 (outer shell removed)	—	7424 112		Order No.
	② Adaptor(s) , CPVC 60mm to 2"	7134 769			Order No.
	③ Adaptor(s) , stainless steel 80mm to 3"	—	field supplied	field supplied	and field supplied
	3" to 4" (not shown)	—	—	—	
	③ Adaptor(s) , CPVC 2" to 3"	—	field supplied	field supplied	and field supplied
	3" to 4" (not shown)	—	—	—	
	④ Venting Support ²	field supplied			
	⑤ ULC/UL listed Stainless Steel Vent Material ^{1a} for EqL calculations, use: ■ 45° Elbow EqL = 2ft. / 0.6m ■ 90° Elbow EqL = 3ft. / 0.9m or ⑤ ULC/UL listed CPVC Vent Material ^{1b} for EqL calculations, use: ■ 45° Elbow EqL = 3ft. / 0.9m ■ 90° Elbow EqL = 5ft. / 1.5m	field supplied			
	⑥ Adaptor(s) , CPVC 60mm to 2"	7134 769			Order No.
⑦ 2" to 3" or 2" to 4"	field supplied				
⑧ Combustion Air Intake Vent Material Allowable materials: see note below ³	field supplied				
⑨ Bird Screen c/w Termination for stainless steel or ⑨ Bird Screen (Set of 2) for CPVC	field supplied				
	7134 780	7134 781	7134 782	Order No.	

^{1a}Stainless steel vent material **must** be ULC/UL listed, stainless steel AL29-4C® for Category IV boilers.
Suggested sources: Flexmaster Canada Ltd. / Z-Flex (US) Inc., Heat-fab, ProTech Systems Inc., or Security Chimneys Int'l.
^{1b}CPVC vent material **must** be ULC/UL listed, for Category IV boilers. Suggested source: IPEX Inc.
²Boiler cannot support weight of vent system. Support venting as prescribed in vent manufacturer's installation instructions.
³Combustion air supply pipe may be made of the following materials: ABS, CPVC, PVC, or stainless steel.
▶ Do **not** include first 90° elbow in equivalent vent length calculations (this applies to all vent materials).
▶ A **maximum** of 5 x 90° elbows may be installed in the air intake and flue outlet combined; do **not** exceed maximum equivalent vent length.
▶ Always follow Viessmann venting installation instructions 5368 815.

Viessmann Manufacturing Company (U.S.) Inc.
45 Access Road
Warwick, Rhode Island • 02886 • USA
1-800-288-0667 • Fax (401) 732-0590
www.viessmann-us.com • info@viessmann-us.com

Viessmann Manufacturing Company Inc.
750 McMurray Road
Waterloo, Ontario • N2V 2G5 • Canada
1-800-387-7373 • Fax (519) 885-0887
www.viessmann.ca • info@viessmann.ca

