

**City of Portland, Maine - Building or Use Permit Application**

389 Congress Street, 04101 Tel: (207) 874-8703, Fax: (207) 874-8716

Permit No: 02-0566	Issue Date: JUL - 8 2002	CB#: 428 C003001
-----------------------	-----------------------------	------------------

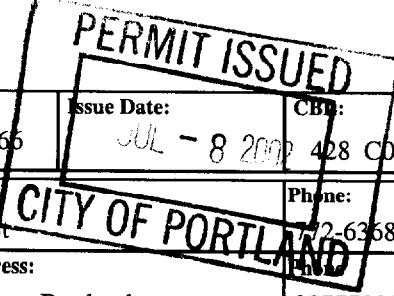

Location of Construction: 537 Washington Ave	Owner Name: Waltz Richard P	Owner Address: 140 Ludlow St	Phone: 72-6368
Business Name:	Contractor Name: Richard P. Waltz 772-2801	Contractor Address: 179 Presumpscot Portland	2077722801
Lessee/Buyer's Name	Phone:	Permit Type: Alterations - Dwellings	Zone: R-5

Past Use: Single Family	Proposed Use: Single Family	Permit Fee: \$58.00	Cost of Work: \$5,000.00	CEO District: 2
		FIRE DEPT: <input type="checkbox"/> Approved <input checked="" type="checkbox"/> Denied N/A	INSPECTION: Use Group: R-3 Type: SB BOLA 1999	

Proposed Project Description:  
Replacing Existing 8' x 20.3' Porch and Adding a 20' x 12' Deck.

*Not building deck -  
Deck not approved.*

Signature: *[Signature]*

Signature: *[Signature]*

PEDESTRIAN ACTIVITIES DISTRICT (P.A.D.)

Action:  Approved  Approved w/Conditions  Denied

Signature: \_\_\_\_\_ Date: \_\_\_\_\_

Permit Taken By: gad	Date Applied For: 05/24/2002	<b>Zoning Approval</b>		
-------------------------	---------------------------------	------------------------	--	--

<p>1. This permit application does not preclude the Applicant(s) from meeting applicable State and Federal Rules.</p> <p>2. Building permits do not include plumbing, septic or electrical work.</p> <p>3. Building permits are void if work is not started within six (6) months of the date of issuance. False information may invalidate a building permit and stop all work..</p>	<p><b>Special Zone or Reviews</b></p> <p><input type="checkbox"/> Shoreland</p> <p><input type="checkbox"/> Wetland</p> <p><input type="checkbox"/> Flood Zone</p> <p><input type="checkbox"/> Subdivision</p> <p><input type="checkbox"/> Site Plan</p> <p>Maj <input type="checkbox"/> Minor <input type="checkbox"/> MM <input type="checkbox"/></p> <p>Date: 7/3/02</p>	<p><b>Zoning Appeal</b></p> <p><input type="checkbox"/> Variance</p> <p><input type="checkbox"/> Miscellaneous</p> <p><input type="checkbox"/> Conditional Use</p> <p><input type="checkbox"/> Interpretation</p> <p><input type="checkbox"/> Approved</p> <p><input type="checkbox"/> Denied</p> <p>Date: _____</p>	<p><b>Historic Preservation</b></p> <p><input checked="" type="checkbox"/> Not in District or Landmark</p> <p><input type="checkbox"/> Does Not Require Review</p> <p><input type="checkbox"/> Requires Review</p> <p><input type="checkbox"/> Approved</p> <p><input type="checkbox"/> Approved w/Conditions</p> <p><input type="checkbox"/> Denied</p> <p>Date: 7/3/02</p>
---	---	--	--

**CERTIFICATION**

I hereby certify that I am the owner of record of the named property, or that the proposed work is authorized by the owner of record and that I have been authorized by the owner to make this application as his authorized agent and I agree to conform to all applicable laws of this jurisdiction. In addition, if a permit for work described in the application is issued, I certify that the code official's authorized representative shall have the authority to enter all areas covered by such permit at any reasonable hour to enforce the provision of the code(s) applicable to such permit.

SIGNATURE OF APPLICANT \_\_\_\_\_ ADDRESS \_\_\_\_\_ DATE \_\_\_\_\_ PHONE \_\_\_\_\_

RESPONSIBLE PERSON IN CHARGE OF WORK, TITLE \_\_\_\_\_ DATE \_\_\_\_\_ PHONE \_\_\_\_\_

# DISPLAY THIS CARD ON PRINCIPAL FRONTAGE OF WORK CITY OF PORTLAND

Please Read  
Application And  
Notes, If Any,  
Attached

BUILDING INSPECTION

## PERMIT

Permit Number: 020566

This is to certify that Waltz Richard P/Richard P. Waltz  
has permission to Replacing Existing 8' x 20.3' Arch and adding a 8' x 12' Deck  
AT 537 Washington Ave 428 C003001

provided that the person or persons, firm or corporation accepting this permit shall comply with all of the provisions of the Statutes of Maine and of the Ordinances of the City of Portland regulating the construction, maintenance and use of buildings and structures, and of the application on file in this department.

Apply to Public Works for street line and grade if nature of work requires such information.

Notification of inspection must be given and written permission procured before this building or part thereof is altered or closed-in.  
**HEAVY NOTICE IS REQUIRED.**

A certificate of occupancy must be procured by owner before this building or part thereof is occupied.

### OTHER REQUIRED APPROVALS

Fire Dept. \_\_\_\_\_  
Health Dept. \_\_\_\_\_  
Appeal Board \_\_\_\_\_  
Other \_\_\_\_\_  
Department Name

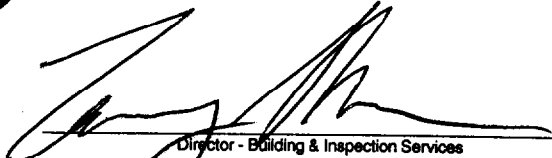
  
Director - Building & Inspection Services

**PENALTY FOR REMOVING THIS CARD**

02-0506

# All Purpose Building Permit Application

If you or the property owner owes real estate or personal property taxes or user charges on any property within the City, payment arrangements must be made before permits of any kind are accepted.

Location/Address of Construction: <u>537 Washington Avenue</u>		
Total Square Footage of Proposed Structure	Square Footage of Lot <u>7,800</u>	
Tax Assessor's Chart, Block & Lot Chart# <u>428</u> Block# <u>C</u> Lot# <u>003</u>	Owner: <u>Richard P. Wultz Sr.</u>	Telephone: <u>207-772-6368</u>
Lessee/Buyer's Name (If Applicable) <u>N/A</u>	Applicant name, address & telephone: <u>536 WASHINGTON</u> <u>772-2801 * Dick</u>	Cost Of Work: \$ <u>5,000</u> Fee: \$ <u>58.—</u>
Current use: <u>Residence / Single Family III</u>		
If the location is currently vacant, what was prior use: _____		
Approximately how long has it been vacant: _____		
Proposed use: <u>Same</u>		
Project description: <u>Replacing existing 8' x 20' 3" porch adding 20 x 12 Deck</u>		
Contractor's name, address & telephone: <u>Richard P. Wultz Plg. &amp; Htg. Co., Inc</u> <u>536 Washington Avenue Portland, Me. 04103 207 772 2801</u>		
Who should we contact when the permit is ready: <u>Richard Bernier</u>		
Mailing address: <u>536 Washington Ave.</u> <u>Portland, Me. 04103</u>		
We will contact you by phone when the permit is ready. You must come in and pick up the permit and review the requirements before starting any work, with a Plan Reviewer. A stop work order will be issued and a \$100.00 fee if any work starts before the permit is picked up. PHONE: <u>772 2801</u>		

IF THE REQUIRED INFORMATION IS NOT INCLUDED IN THE SUBMISSIONS THE PERMIT WILL BE AUTOMATICALLY DENIED AT THE DISCRETION OF THE BUILDING/PLANNING DEPARTMENT, WE MAY REQUIRE ADDITIONAL INFORMATION IN ORDER TO APPROVE THIS PERMIT.

I hereby certify that I am the Owner of record of the named property, or that the owner of record authorizes the proposed work and that I have been authorized by the owner to make this application as his/her authorized agent. I agree to conform to all applicable laws of this jurisdiction. In addition, if a permit for work described in this application is issued, I certify that the Code Official's authorized representative shall have the authority to enter all areas covered by this permit at any reasonable hour to enforce the provisions of the codes applicable to this permit.

Signature of applicant: <u>R. P. Wultz Sr.</u>	Date: <u>5-20-02</u>
--	----------------------

This is NOT a permit, you may not commence ANY work until the permit is issued. If you are in a Historic District you may be subject to additional permitting and fees with the Planning Department on the 4th floor of City Hall

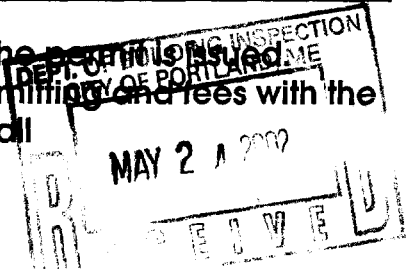

Existing House

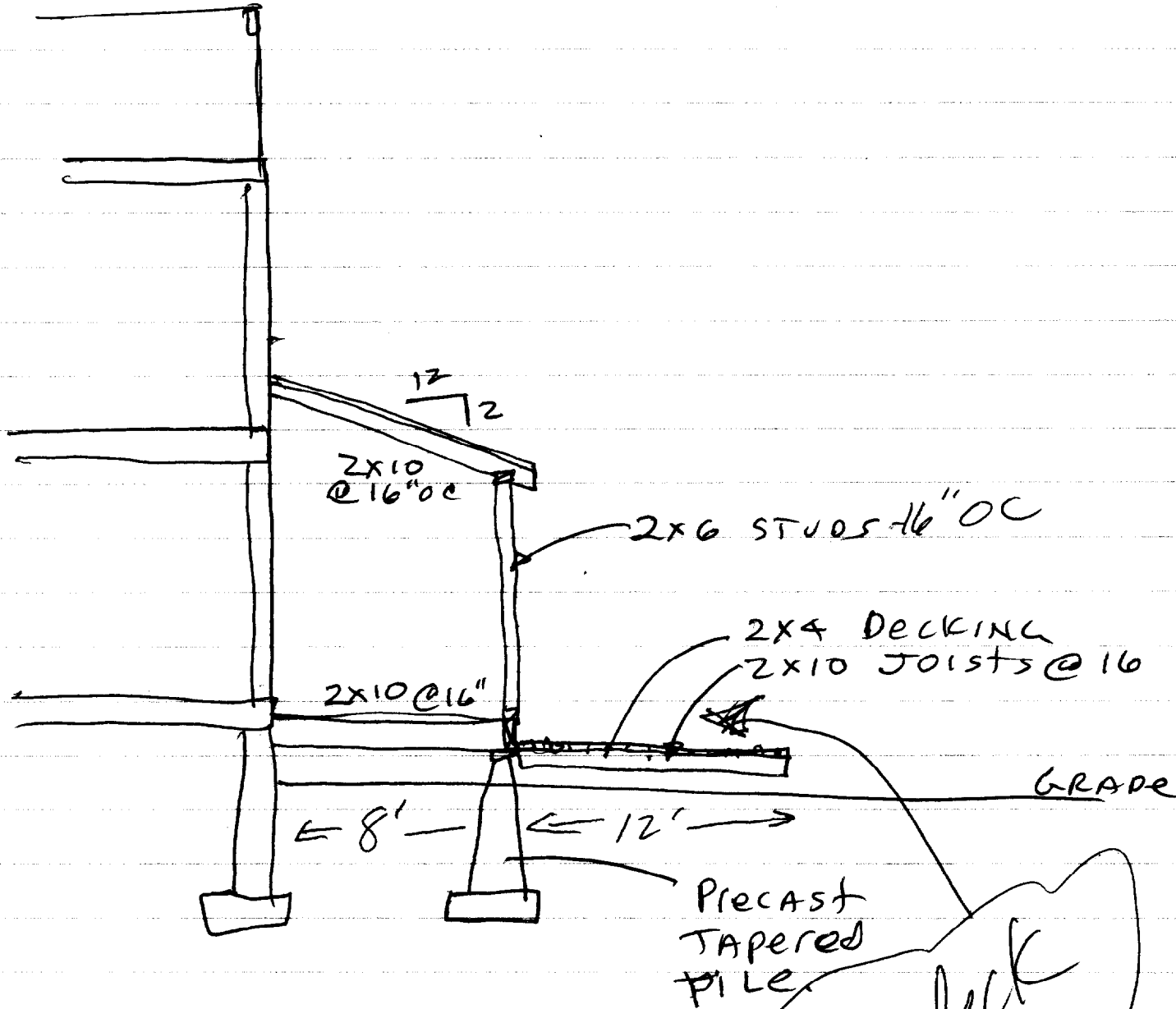

Not doing deck

Rear - 20' Rear  
Side - 8'

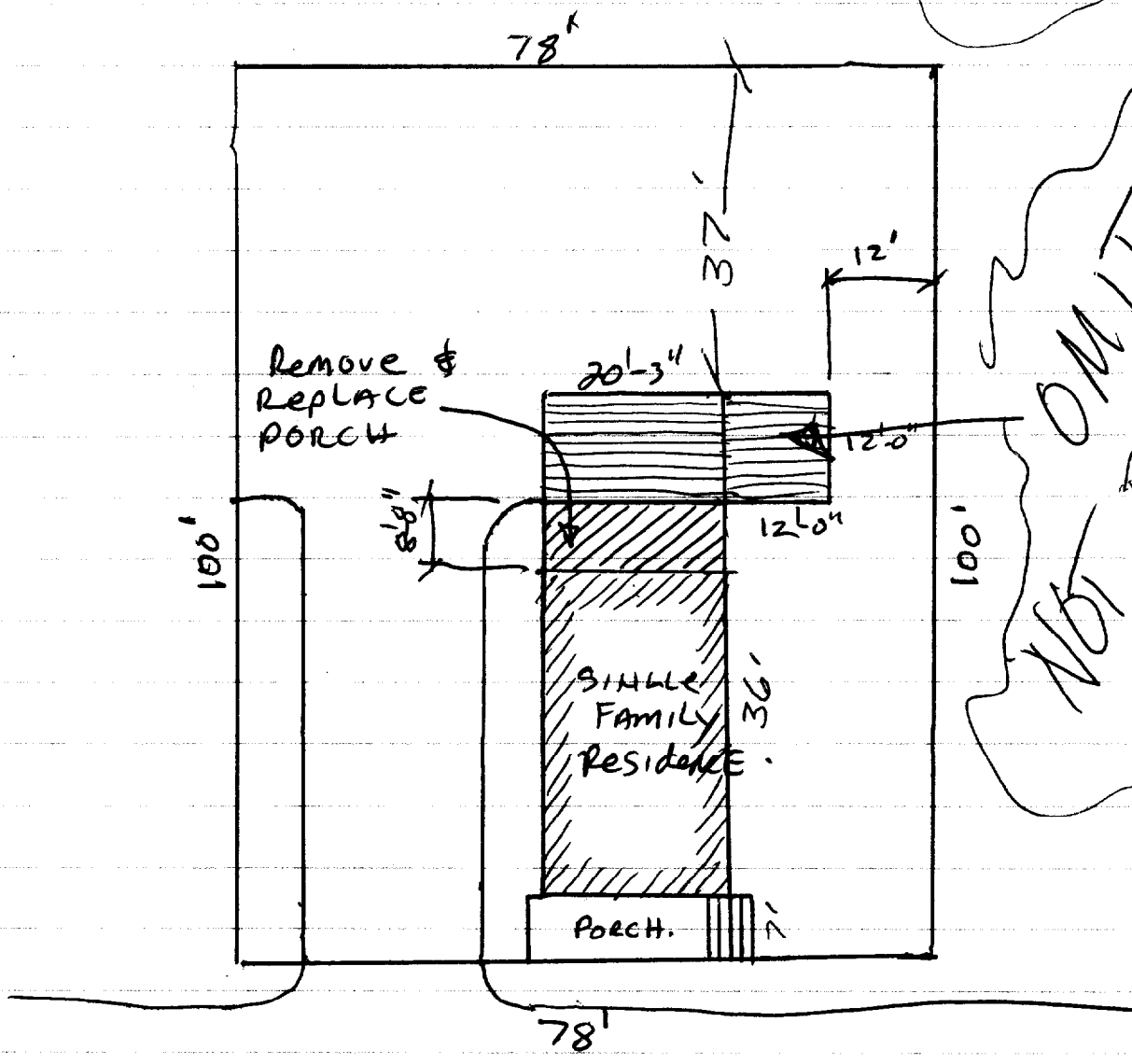

WASHINGTON AVE.

# BUILDING PERMIT INSPECTION PROCEDURES

Please call 874-8703 or ~~874-8632~~ to schedule your inspections as agreed upon

Permits expire in 6 months, if the project is not started or ceases for 6 months.

The Owner or their designee is required to notify the inspections office for the following inspections and provide adequate notice. Notice must be called in 48-72 hours in advance in order to schedule an inspection:

By initializing at each inspection time, you are agreeing that you understand the inspection procedure and additional fees from a "Stop Work Order" and "Stop Work Order Release" will be incurred if the procedure is not followed as stated below.

\_\_\_\_\_ **Pre-construction Meeting:** Must be scheduled with your inspection team upon receipt of this permit. Jay Reynolds, Development Review Coordinator at 874-8632 must also be contacted at this time, before any site work begins on any project other than single family additions or alterations.

- Footing/Building Location Inspection:** Prior to pouring concrete
- N/A **Re-Bar Schedule Inspection:** Prior to pouring concrete
- N/A **Foundation Inspection:** Prior to placing ANY backfill
- Framing/Rough Plumbing/Electrical:** Prior to any insulating or drywalling
- Final/Certificate of Occupancy:** Prior to any occupancy of the structure or use. NOTE: There is a \$75.00 fee per inspection at this point.

Certificate of Occupancy is not required for certain projects. Your inspector can advise you if your project requires a Certificate of Occupancy. All projects DO require a final inspection

\_\_\_\_\_ **If any of the inspections do not occur, the project cannot go on to the next phase, REGARDLESS OF THE NOTICE OR CIRCUMSTANCES.**

\_\_\_\_\_ **CERIFICATE OF OCCUPANICES MUST BE ISSUED AND PAID FOR, BEFORE THE SPACE MAY BE OCCUPIED**

x Maria Kelly  
Signature of applicant/designee

Date 7/9/02

Signature of Inspections Official

Date

CBL: 428-003 Building Permit #: 02-0566