

City of Portland, Maine – Building or Use Permit Application 389 Congress Street, 04101, Tel: (207) 874-8703, FAX: 874-8716

Location of Construction: <i>24 Presumpscott Street Portland 04103</i>		Owner: <i>Robert Poor</i>		Phone: <i>871-0701 711-3480</i>		Permit No: <i>990775</i>	
Owner Address: <i>SAA</i>		Lessee/Buyer's Name:		Phone:		BusinessName:	
Contractor Name:		Address:		Phone:		<div style="border: 2px solid black; padding: 5px; text-align: center;"> PERMIT ISSUED Permit Issued: JUL 22 1999 CITY OF PORTLAND </div>	
Past Use: <i>3 family</i>		Proposed Use: <i>same</i>		COST OF WORK: <i>\$500.00</i>			
Proposed Project Description: <i>6x14 deck rplacing existing rear porch</i>		FIRE DEPT. <input type="checkbox"/> Approved <input type="checkbox"/> Denied Signature:		INSPECTION: Use Group <i>R2</i> Type <i>5B</i> <i>BOC 496</i>		Zone: CBL: <i>428-L-003</i>	
				PEDESTRIAN ACTIVITIES DISTRICT (P.A.D.) Action: Approved <input type="checkbox"/> Approved with Conditions: <input type="checkbox"/> Denied <input type="checkbox"/> Signature: Date:		Zoning Approval: Special Zone or Reviews: <input type="checkbox"/> Shoreland <input type="checkbox"/> Wetland <input type="checkbox"/> Flood Zone <input type="checkbox"/> Subdivision <input type="checkbox"/> Site Plan maj <input type="checkbox"/> minor <input type="checkbox"/> mm <input type="checkbox"/>	
Permit Taken By: <i>SP</i>		Date Applied For: <i>July 12, 1999 K.</i>					

1. This permit application does not preclude the Applicant(s) from meeting applicable State and Federal rules.
2. Building permits do not include plumbing, septic or electrical work.
3. Building permits are void if work is not started within six (6) months of the date of issuance. False information may invalidate a building permit and stop all work..

**PERMIT ISSUED
WITH REQUIREMENTS**

CERTIFICATION

I hereby certify that I am the owner of record of the named property, or that the proposed work is authorized by the owner of record and that I have been authorized by the owner to make this application as his authorized agent and I agree to conform to all applicable laws of this jurisdiction. In addition, if a permit for work described in the application is issued, I certify that the code official's authorized representative shall have the authority to enter all areas covered by such permit at any reasonable hour to enforce the provisions of the code(s) applicable to such permit

SIGNATURE OF APPLICANT	ADDRESS:	DATE: <i>July 12, 1999</i>	PHONE:
RESPONSIBLE PERSON IN CHARGE OF WORK, TITLE			PHONE:

- Historic Preservation**
- Not in District or Landmark
 - Does Not Require Review
 - Requires Review

- Action:
- Approved
 - Approved with Conditions
 - Denied

Date: _____

CEO DISTRICT

2

COMMENTS

7/26/99 - owner called for pre/con - new deck is larger (extends into
near setback) - Referred him to Marge S. @ 8695. Discussed footings / Anchors /
Guard Rails / handrails / Treads & Risers / - No other questions by owner.
He will call B-4 pouring tubes - 7/26 - owner called Marge Schumaker.

7/29/99 - Went to site tubes all poured structure HAS been REDUCED FROM ORIGINAL
in size JN

Inspection Record

Type	Date
Foundation: _____	_____
Framing: _____	_____
Plumbing: _____	_____
Final: _____	_____
Other: _____	_____

THIS IS NOT A PERMIT/CONSTRUCTION CANNOT COMMENCE UNTIL THE PERMIT IS ISSUED

**Building or Use Permit Pre-Application
Attached Single Family Dwellings/Two-Family Dwelling
Multi-Family or Commercial Structures and Additions Thereto**

In the interest of processing your application in the quickest possible manner, please complete the Information below for a Building or Use Permit.

NOTEIf you or the property owner owes real estate or personal property taxes or user charges on ANY PROPERTY within the City, payment arrangements must be made before permits of any kind are accepted.**

Location/Address of Construction (include Portion of Building): 24 Rossumscot St			
Total Square Footage of Proposed Structure 84 sq ft		Square Footage of Lot 4800 sq ft	
Tax Assessor's Chart, Block & Lot Number Chart# 428 Block# L Lot# 003		Owner: Robert Ross	Telephone#: 871-0701
Owner's Address: 24 Rossumscot St Portland, ME 04103		Lessee/Buyer's Name (If Applicable)	Cost Of Work: \$ 500.00 Fee \$ 30.00
Proposed Project Description: (Please be as specific as possible) A 6'x14' Deck replacing existing deck near Rosch.			
Contractor's Name, Address & Telephone Owner			Rec'd By [Signature]
Current Use: 3-fam		Proposed Use: Same	

Separate permits are required for Internal & External Plumbing, HVAC and Electrical installation.

- All construction must be conducted in compliance with the 1996 B.O.C.A. Building Code as amended by Section 6-Art II.
- All plumbing must be conducted in compliance with the State of Maine Plumbing Code.
- All Electrical Installation must comply with the 1996 National Electrical Code as amended by Section 6-Art III.
- HVAC (Heating, Ventilation and Air Conditioning) installation must comply with the 1993 BOCA Mechanical Code.

You must Include the following with you application:

- 1) A Copy of Your Deed or Purchase and Sale Agreement
- 2) A Copy of your Construction Contract, if available
- 3) A Plot Plan/Site Plan

Minor or Major site plan review will be required for the above proposed projects. The attached checklist outlines the minimum standards for a site plan.

4) Building Plans

Unless exempted by State Law, construction documents must be designed by a registered design professional.

A complete set of construction drawings showing all of the following elements of construction:

- Cross Sections w/Framing details (including porches, decks w/ railings, and accessory structures)
- Floor Plans & Elevations
- Window and door schedules
- Foundation plans with required drainage and dampproofing
- Electrical and plumbing layout. Mechanical drawings for any specialized equipment such as furnaces, chimneys, gas equipment, HVAC equipment (air handling) or other types of work that may require special review must be included.

Certification

I hereby certify that I am the Owner of record of the named property, or that the proposed work is authorized by the owner of record and that I have been authorized by the owner to make this application as his/her authorized agent. I agree to conform to all applicable laws of this jurisdiction. In addition, if a permit for work described in this application is issued, I certify that the Code Official's authorized representative shall have the authority to enter all areas covered by this permit at any reasonable hour to enforce the provisions of the codes applicable to this permit.

Signature of applicant: [Signature]	Date: 7/12/99
--	----------------------

Building Permit Fee: \$30.00 for the 1st \$1000.cost plus \$6.00 per \$1,000.00 construction cost thereafter.

Additional Site review and related fees are attached on a separate addendum

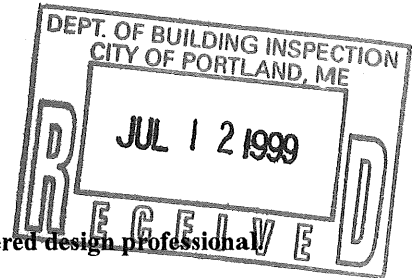

Inspection Services
Michael J. Nugent
Manager



Department of Urban Development
Joseph E. Gray, Jr.
Director

CITY OF PORTLAND

congratulations!!!!!!

**Building or Use Permit Application
Attached Single Family Dwellings/Two-Family Dwelling
Multi-Family or Commercial Structures and Additions Thereto**

As an applicant for a building permit, you are about to enter into a relationship with our Office. We welcome any questions, comments or suggestions that will make the process more efficient. Attached you will find an application and some samples of the submissions you will provide at application time. Please read ***ALL*** of the information and if you need any further assistance please call 874-8703 or 874-8693.

Minor or Major site plan review will be required for the most of the above proposed projects.

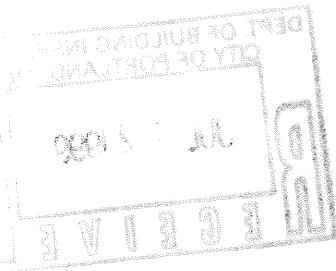

Existing House

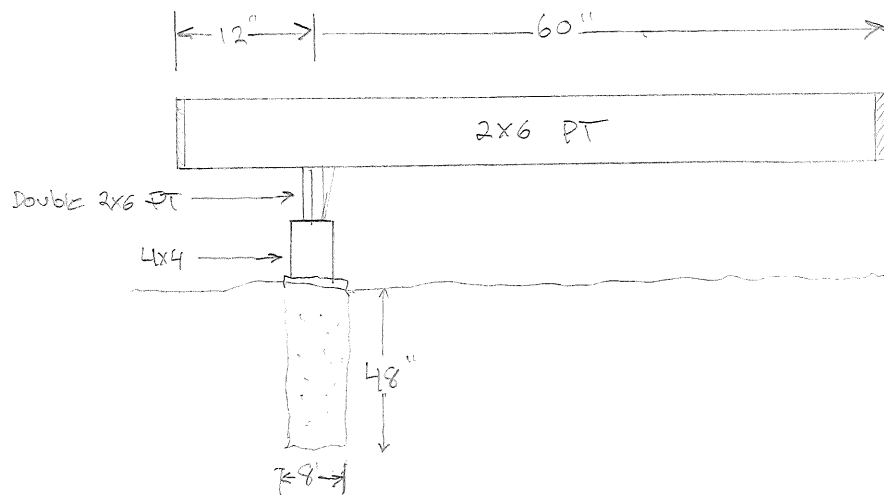

BUILDING PERMIT REPORT

DATE: 17 July 99 ADDRESS: 24 Presumpscott St CBL: 428-1-003

REASON FOR PERMIT: To replace 6x14' deck

BUILDING OWNER: Robert Poor

PERMIT APPLICANT: _____

USE GROUP R-2 BOCA 1996 CONSTRUCTION TYPE 5B

CONDITION(S) OF APPROVAL

This permit is being issued with the understanding that the following conditions are met:

Approved with the following conditions: *1, *11, *13, *29, *32, *34, #31

1. This permit does not excuse the applicant from meeting applicable State and Federal rules and laws.
2. Before concrete for foundation is placed, approvals from the Development Review Coordinator and Inspection Services must be obtained. (A 24 hour notice is required prior to inspection)
3. Foundation drain shall be placed around the perimeter of a foundation that consists of gravel or crushed stone containing not more than 10 percent material that passes through a No. 4 sieve. The drain shall extend a minimum of 12 inches beyond the outside edge of the footing. The thickness shall be such that the bottom of the drain is not higher than the bottom of the base under the floor, and that the top of the drain is not less than 6 inches above the top of the footing. The top of the drain shall be covered with an approved filter membrane material. Where a drain tile or perforated pipe is used, the invert of the pipe or tile shall not be higher than the floor elevation. The top of joints or top of perforations shall be protected with an approved filter membrane material. The pipe or tile shall be placed on not less than 2" of gravel or crushed stone, and shall be covered with not less than 6" of the same material. Section 1813.5.2
4. Foundations anchors shall be a minimum of 1/2" in diameter, 7" into the foundation wall, minimum of 12" from corners of foundation and a maximum 6' o.c. between bolts. (Section 2305.17)
5. Waterproofing and dampproofing shall be done in accordance with Section 1813.0 of the building code.
6. Precaution must be taken to protect concrete from freezing. Section 1908.0
7. It is strongly recommended that a registered land surveyor check all foundation forms before concrete is placed. This is done to verify that the proper setbacks are maintained.
8. Private garages located beneath habitable rooms in occupancies in Use Group R-1, R-2, R-3 or I-1 shall be separated from adjacent interior spaces by fire partitions and floor/ceiling assembly which are constructed with not less than 1-hour fire resisting rating. Private garages attached side-by-side to rooms in the above occupancies shall be completely separated from the interior spaces and the attic area by means of 1/2 inch gypsum board or the equivalent applied to the garage means of 1/2 inch gypsum board or the equivalent applied to the garage side. (Chapter 4, Section 407.0 of the BOCA/1996)
9. All chimneys and vents shall be installed and maintained as per Chapter 12 of the City's Mechanical Code. (The BOCA National Mechanical Code/1993). Chapter 12 & NFPA 211
10. Sound transmission control in residential building shall be done in accordance with Chapter 12, Section 1214.0 of the City's Building Code.
11. Guardrails & Handrails: A guardrail system is a system of building components located near the open sides of elevated walking surfaces for the purpose of minimizing the possibility of an accidental fall from the walking surface to the lower level. Minimum height all Use Groups 42", except Use Group R which is 36". In occupancies in Use Group A, B, H-4, I-1, I-2, M and R and public garages and open parking structures, open guards shall have balusters or be of solid material such that a sphere with a diameter of 4" cannot pass through any opening. Guards shall not have an ornamental pattern that would provide a ladder effect. (Handrails shall be a minimum of 36" but not more than 38". Use Group R-3 shall not be less than 30", but not more than 38".) Handrail grip size shall have a circular cross section with an outside diameter of at least 1 1/4" and not greater than 2". (Sections 1021 & 1022.0) - Handrails shall be on both sides of stairway. (Section 1014.7)
12. Headroom in habitable space is a minimum of 7'6". (Section 1204.0)
13. Stair construction in Use Group R-3 & R-4 is a minimum of 10" tread and 7 1/4" maximum rise. All other Use Group minimum 11" tread, 7" maximum rise. (Section 1014.0)
14. The minimum headroom in all parts of a stairway shall not be less than 80 inches. (6'8") 1014.4
15. Every sleeping room below the fourth story in buildings of Use Groups R and I-1 shall have at least one operable window or exterior door approved for emergency egress or rescue. The units must be operable from the inside without the use of special knowledge or separate tools. Where windows are provided as means of egress or rescue they shall have a sill height not more than 44 inches (1118mm) above the floor. All egress or rescue windows from sleeping rooms shall have a minimum net clear opening height dimension of 24 inches (610mm). The minimum net clear opening width dimension shall be 20 inches (508mm), and a minimum net clear opening of 5.7 sq. ft. (Section 1018.6)
16. Each apartment shall have access to two (2) separate, remote and approved means of egress. A single exit is acceptable when it exits directly from the apartment to the building exterior with no communications to other apartment units. (Section 1010.1)
17. All vertical openings shall be enclosed with construction having a fire rating of at least one (1) hour, including fire doors with self closer's. (Over 3 stories in height requirements for fire rating is two (2) hours.) (Section 710.0)
18. The boiler shall be protected by enclosing with (1)hour fire rated construction including fire doors and ceiling, or by providing automatic extinguishment. (Table 302.1.1)
19. All single and multiple station smoke detectors shall be of an approved type and shall be installed in accordance with the provisions of the City's Building Code Chapter 9, Section 920.3.2 (BOCA National Building Code/1996), and NFPA 101 Chapter 18 & 19. (Smoke detectors shall be

installed and maintained at the following locations):

- In the immediate vicinity of bedrooms
- In all bedrooms
- In each story within a dwelling unit, including basements

In addition to the required AC primary power source, required smoke detectors in occupancies in Use Groups R-2, R-3 and I-1 shall receive power from a battery when the AC primary power source is interrupted. (Interconnection is required) Section 920.3.2.

20. A portable fire extinguisher shall be located as per NFPA #10. They shall bear the label of an approved agency and be of an approved type. (Section 921.0)
21. The Fire Alarm System shall maintained to NFPA #72 Standard.
22. The Sprinkler System shall maintained to NFPA #13 Standard.
23. All exit signs, lights and means of egress lighting shall be done in accordance with Chapter 10 Section & Subsections 1023.0 & 1024.0 of the City's Building Code. (The BOCA National Building Code/1996)
24. Section 25-135 of the Municipal Code for the City of Portland states, "No person or utility shall be granted a permit to excavate or open any street or sidewalk from the time of November 15 of each year to April 15 of the following year".
25. The builder of a facility to which Section 4594-C of the Maine State Human Rights Act Title 5 MRSA refers, shall obtain a certification from a design professional that the plans commencing construction of the facility, the builder shall submit the certification the Division of Inspection Services.
26. Ventilation shall meet the requirements of Chapter 12 Sections 1210.0 of the City's Building Code. (Crawl spaces & attics).
27. All electrical, plumbing and HVAC permits must be obtained by a Master Licensed holders of their trade. No closing in of walls until all electrical (min. 72 hours notice) and plumbing inspections have been done.
28. All requirements must be met before a final Certificate of Occupancy is issued.
- X 29. All building elements shall meet the fastening schedule as per Table 2305.2 of the City's Building Code (the BOCA National Building Code/1996).
30. Ventilation of spaces within a building shall be done in accordance with the City's Mechanical Code (The BOCA National Mechanical Code/1993). (Chapter M-16)
- (31) Please read and implement the attached Land Use Zoning report requirements. *rear of New deck shall not be closer to the rear lot line than the old porch.*
- X 32. Boring, cutting and notching shall be done in accordance with Sections 2305.4.4, 2305.5.1 and 2305.5.3 of the City's Building Code.
33. Glass and glazing shall meet the requirements of Chapter 24 of the building code.
- X 34. IF The pier foundation is new The piers must rest on a footing with and anchor connecting The Two - Also, The 4"x4" post must be fastened to the pier & Framing of the deck.
35. _____
36. _____

[Signature]
Building Inspector

cc: L. McDougall, PFD

Marge Schmuckal, Zoning Administrator

PSH 12-14-91

**On the basis of plans submitted and conditions placed on these plans any deviations shall require a separate approval.

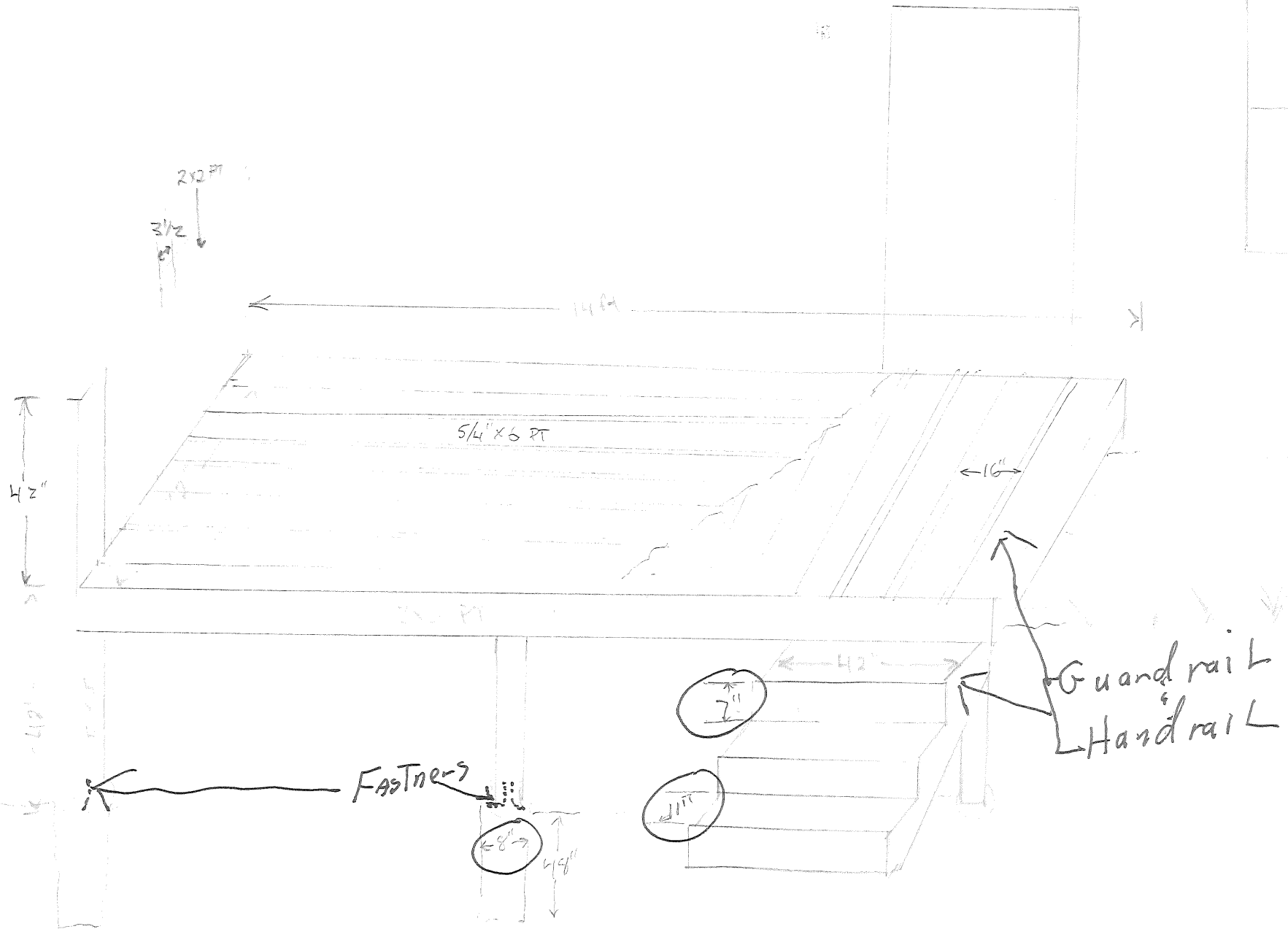

Property Line

Historic (Property) Line

Back Driveway

22' 8"

22' 8"

Deck

Side Reg. 8' shows 22' 8" ok

Replaces Existing Porch

72"

CAN NOT be closer to rear than the old structure

Front of House

Front Driveway

Savoy ST 33'

Presumpscot ST

25' 10" sidewalk

