

City of Portland, Maine - Building or Use Permit Application
 389 Congress Street, 04101 Tel: (207) 874-8703, Fax: (207) 874-8716

Permit No: 08-1289	Issue Date:	CBL: 428 L002001
-----------------------	-------------	---------------------

Location of Construction: 20 PRESUMPCOT ST	Owner Name: GIROUX JAMES R	Owner Address: PO BOX 11082	Phone:
Business Name:	Contractor Name: Down East Energy	Contractor Address: 172 Main Street South Portland	Phone 2077995585
Lessee/Buyer's Name	Phone:	Permit Type: Tanks - Dwellings	Zone: R-5

Past Use: 3 unit <i>legal use - 3 div.</i>	Proposed Use: 3 unit - 120 Gallon propane Tank & a Rinnai 556 FA	Permit Fee: \$40.00	Cost of Work: \$21,000.00	CEO District: 4
		FIRE DEPT: <input checked="" type="checkbox"/> Approved <input type="checkbox"/> Denied <i>TO UTPA 58</i>	INSPECTION: Use Group: <i>R2</i> Type: <i>HVAC UP TANK</i> <i>IMC-2003</i>	

Proposed Project Description: 120 Gallon propane Tank & a Rinnai 556 FA	Signature: <i>Greg Curran</i>	Signature: <i>JMB 11/14/08</i>
PEDESTRIAN ACTIVITIES DISTRICT (P.A.D.)		
Action: <input type="checkbox"/> Approved <input type="checkbox"/> Approved w/Conditions <input type="checkbox"/> Denied		
Signature: _____ Date: _____		

Permit Taken By: Idobson	Date Applied For: <i>12/13</i> 11/05/2008	Zoning Approval
-----------------------------	---	------------------------

1. This permit application does not preclude the Applicant(s) from meeting applicable State and Federal Rules. 2. Building permits do not include plumbing, septic or electrical work. 3. Building permits are void if work is not started within six (6) months of the date of issuance. False information may invalidate a building permit and stop all work..	Special Zone or Reviews <input type="checkbox"/> Shoreland <input type="checkbox"/> Wetland <input type="checkbox"/> Flood Zone <input type="checkbox"/> Subdivision <input type="checkbox"/> Site Plan Maj <input type="checkbox"/> Minor <input type="checkbox"/> MM <input type="checkbox"/> <i>OK w/ conditions</i> Date: <i>11/6/08 Arsen</i>	Zoning Appeal <input type="checkbox"/> Variance <input type="checkbox"/> Miscellaneous <input type="checkbox"/> Conditional Use <input type="checkbox"/> Interpretation <input type="checkbox"/> Approved <input type="checkbox"/> Denied Date: _____	Historic Preservation <input checked="" type="checkbox"/> Not in District or Landmark <input type="checkbox"/> Does Not Require Review <input type="checkbox"/> Requires Review <input type="checkbox"/> Approved <input type="checkbox"/> Approved w/Conditions <input type="checkbox"/> Denied <i>ABH</i> Date: _____
--	---	---	--

CERTIFICATION

I hereby certify that I am the owner of record of the named property, or that the proposed work is authorized by the owner of record and that I have been authorized by the owner to make this application as his authorized agent and I agree to conform to all applicable laws of this jurisdiction. In addition, if a permit for work described in the application is issued, I certify that the code official's authorized representative shall have the authority to enter all areas covered by such permit at any reasonable hour to enforce the provision of the code(s) applicable to such permit.

SIGNATURE OF APPLICANT	ADDRESS	DATE	PHONE
RESPONSIBLE PERSON IN CHARGE OF WORK, TITLE		DATE	PHONE

City of Portland, Maine - Building or Use Permit

389 Congress Street, 04101 Tel: (207) 874-8703, Fax: (207) 874-8716

Permit No: 08-1289	Date Applied For: 10/10/2008	CBL: 428 L002001
------------------------------	--	----------------------------

Location of Construction: 20 PRESUMPCOT ST	Owner Name: GIROUX JAMES R	Owner Address: PO BOX 11082	Phone:
Business Name:	Contractor Name: Down East Energy	Contractor Address: 172 Main Street South Portland	Phone: (207) 799-5585
Lessee/Buyer's Name	Phone:	Permit Type: Tanks - Dwellings	

Proposed Use: 3 unit - 120 Gallon propane Tank & a Rinnai 556 FA	Proposed Project Description: 120 Gallon propane Tank & a Rinnai 556 FA
--	---

Dept: Zoning	Status: Approved with Conditions	Reviewer: Ann Machado	Approval Date: 11/06/2005
Note:			Ok to Issue: <input checked="" type="checkbox"/>
1) This property shall remain a three family dwelling. Any change of use shall require a separate permit application for review and approval.			
2) This permit is being approved on the basis of plans submitted. Any deviations shall require a separate approval before starting that work.			
Dept: Building	Status: Approved with Conditions	Reviewer: Jeanine Bourke	Approval Date: 11/14/2008
Note:			Ok to Issue: <input checked="" type="checkbox"/>
1) The appliance shall be installed in accordance with the IMC 2003 and NFPA 211			
Dept: Fire	Status: Approved with Conditions	Reviewer: Capt Greg Cass	Approval Date: 11/07/2008
Note:			Ok to Issue: <input checked="" type="checkbox"/>
1) Install shall comply with NFPA 58 A compliance letter is required.			

Comments:
10/10/2008-ldobson: Jeanie sent back for more info
11/5/2008-amachado: Lannie recieved required information. Gave permit to zoning.

BUILDING PERMIT INSPECTION PROCEDURES

Please call 874-8703 or 874-8693 (ONLY)

to schedule your inspections as agreed upon

Permits expire in 6 months, if the project is not started or ceases for 6 months.

The Owner or their designee is required to notify the inspections office for the following inspections and provide adequate notice. Notice must be called in 48-72 hours in advance in order to schedule an inspection:

By initializing at each inspection time, you are agreeing that you understand the inspection procedure and additional fees from a "Stop Work Order" and "Stop Work Order Release" will be incurred if the procedure is not followed as stated below.

A Pre-construction Meeting will take place upon receipt of your building permit.

 X **Final inspection required at completion of work.**

Certificate of Occupancy is not required for certain projects. Your inspector can advise you if your project requires a Certificate of Occupancy. All projects DO require a final inspection.

If any of the inspections do not occur, the project cannot go on to the next phase, REGARDLESS OF THE NOTICE OR CIRCUMSTANCES.

CERIFICATE OF OCCUPANICES MUST BE ISSUED AND PAID FOR, BEFORE THE SPACE MAY BE OCCUPIED.

Signature of Applicant/Designee

Signature of Inspections Official

Date

Date



FILL IN AND SIGN WITH INK

APPLICATION FOR PERMIT HEATING OR POWER EQUIPMENT

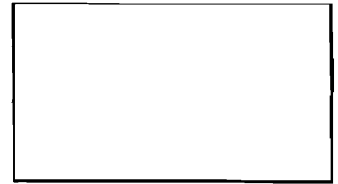

To the INSPECTOR OF BUILDINGS, PORTLAND, ME.

The undersigned hereby applies for a permit to install the following heating, cooking or power equipment in accordance with the Laws of Maine, the Building Code of the City of Portland, and the following specifications:

Location / CBL 48C1 Use of Building 3 unit Home Date 10/10/08
 Name and address of owner of appliance Jim Giroux 20 Presumpscott St
Portland ME 04104 272-2515 871-1913
 Installer's name and address Downeast Energy 172 Main St. South
Portland ME 04106 Telephone 207-744-5585

Location of appliance:

- Basement
- Floor
- Attic
- Roof

Type of Fuel:

- Gas
- Oil
- Solid

Appliance Name:

Rinnai 556FA

U.L. Approved Yes No

Will appliance be installed in accordance with the manufacture's installation instructions? Yes No

IF NO Explain: _____

The Type of License of Installer:

- Master Plumber # _____
- Solid Fuel # _____
- Oil # _____
- Gas # _____
- Other _____

Type of Chimney:

- Masonry Lined
Factory built _____
- Metal
Factory Built U.L. Listing # _____
- Direct Vent
Type Rinnai UL# _____

Type of Fuel Tank

- Oil
- Gas

Wilde
11-5-08

Size of Tank 120 gal

Number of Tanks 1

Distance from Tank to Center of Flame 40 feet.

Cost of Work: \$ 2100⁰⁰

Permit Fee: \$ _____

Approved

Fire: _____
 Ele.: _____
 Bldg.: _____

Approved with Conditions

- See attached letter or requirement

Signature of Installer

Candrea Kaine

Inspector's Signature

Date Approved



**HOME OWNER / INSTALLER
FOR YOUR SAFETY**
THIS MANUAL MUST BE READ IN ITS
ENTIRETY BEFORE OPERATING HEATER

RHFE-556FA III / FTRA III

ENERGYSAVER

GAS DIRECT VENT WALL FURNACE

Owner's Operation and Installation Manual



WARNING: IF THE INFORMATION IN THIS MANUAL IS NOT FOLLOWED EXACTLY, A FIRE OR EXPLOSION MAY RESULT CAUSING PROPERTY DAMAGE, PERSONAL INJURY OR LOSS OF LIFE.

DO NOT STORE OR USE GASOLINE OR OTHER FLAMMABLE VAPORS AND LIQUIDS IN THE VICINITY OF THIS OR ANY OTHER APPLIANCE.

WHAT TO DO IF YOU SMELL GAS

- DO NOT TRY TO LIGHT ANY APPLIANCE.
- DO NOT TOUCH ANY ELECTRICAL SWITCH; DO NOT USE ANY PHONE IN YOUR BUILDING.
- IMMEDIATELY CALL YOUR GAS SUPPLIER FROM A NEIGHBOR'S PHONE. FOLLOW THE GAS SUPPLIER'S INSTRUCTIONS.
- IF YOU CANNOT REACH YOUR GAS SUPPLIER, CALL THE FIRE DEPARTMENT.

INSTALLATION AND SERVICE MUST BE PERFORMED BY A QUALIFIED INSTALLER, SERVICE AGENCY OR THE GAS SUPPLIER.

This appliance may be installed in an aftermarket, permanently located, manufactured home (USA only) or mobile home, where not prohibited by local codes.

This appliance is only for use with the type of gas indicated on the Rating Plate. This appliance is not convertible for use with other gases, unless a certified kit is used.

Rinnai

**INSTALLER: MUST LEAVE MANUAL WITH UNIT AFTER INSTALLATION.
OWNER: RETAIN THIS MANUAL SAFELY, FOR FUTURE REFERENCE.**

CUT-AWAY DIAGRAM

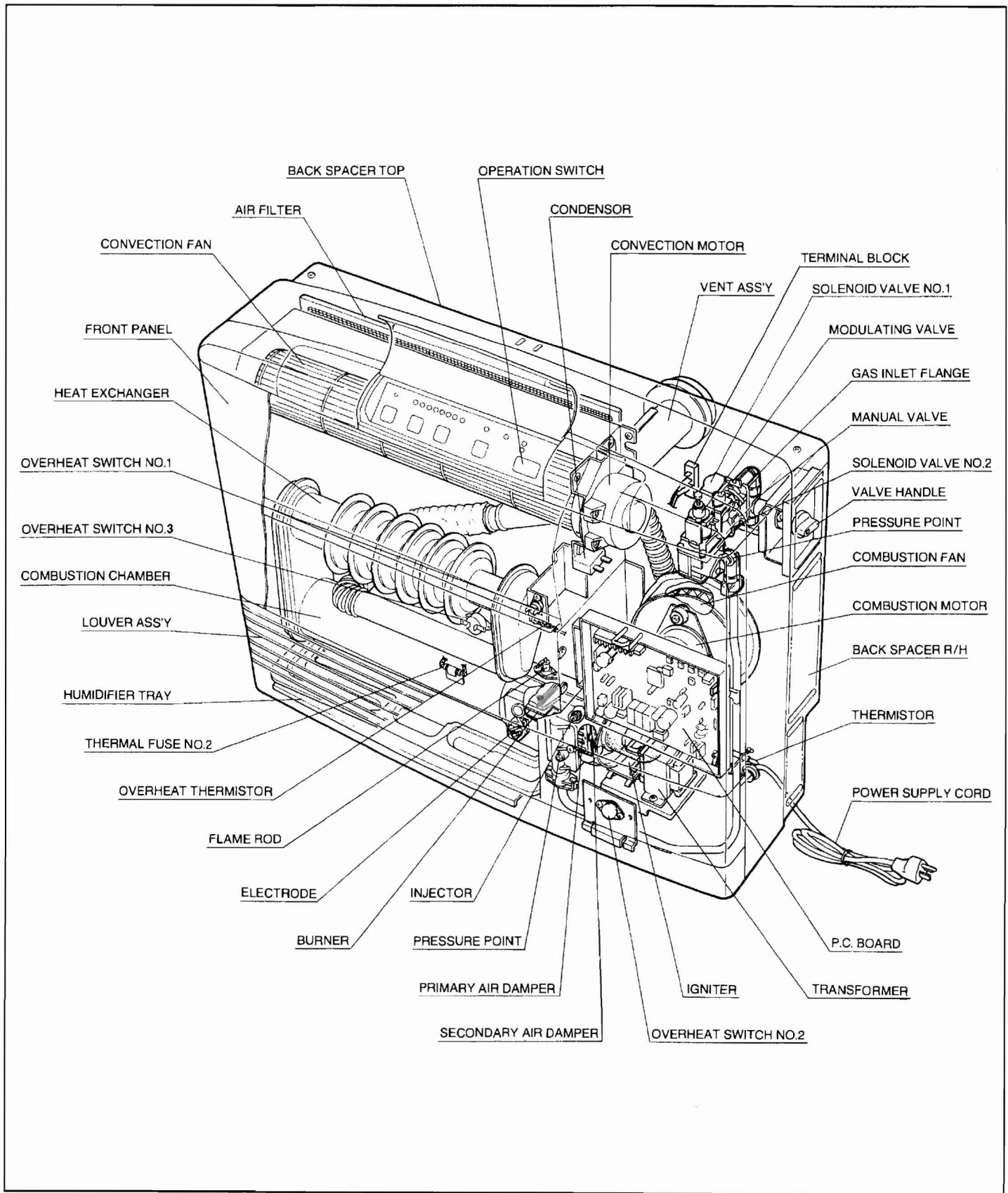

NOTICE BEFORE INSTALLATION

The heater must be installed by a qualified service person according to this installation instruction.

Check your local building codes for the proper method of installation. In the case of absence of local codes, this heater should be installed in accordance with the National Fuel Gas Code ANSI Z223—1.

Check local codes or, in the absence of local codes, the current CAN/CGA—B149 INSTALLATION CODE.

DUE TO HIGH TEMPERATURES, THE APPLIANCE SHOULD BE LOCATED OUT OF TRAFFIC AND AWAY FROM FURNITURE AND DRAPERIES.

CHILDREN AND ADULTS SHOULD BE ALERTED TO THE HAZARDS OF HIGH SURFACE TEMPERATURES AND SHOULD STAY AWAY TO AVOID BURNS OR CLOTHING IGNITION.

“WARNING” Do not operate appliance with the panel(s) removed, cracked or broken. Replacement of the panel(s) should be done by a licensed or qualified service person.

INSTALLATION AND REPAIR SHOULD BE DONE BY A QUALIFIED SERVICE PERSON. THE APPLIANCE SHOULD BE INSPECTED BEFORE USE AND AT LEAST ANNUALLY BY A QUALIFIED SERVICE PERSON. MORE FREQUENT CLEANING MAY BE REQUIRED DUE TO EXCESSIVE LINT FROM CARPETING, BEDDING MATERIAL, ETC. IT IS IMPERATIVE THAT CONTROL COMPARTMENTS, BURNERS AND CIRCULATING AIR PASSAGEWAYS OF THE UNIT BE KEPT CLEAN.

The appliance, when installed, must be electrically grounded in accordance with local codes or, in the absence of local codes, with the National Electrical Code, ANSI/NFPA 70 or Canadian Electrical Code, CSA C22.1, if an external electrical source is utilized.

WARNING: THIS APPLIANCE IS EQUIPPED WITH A THREE-PRONG (GROUNDING) PLUG FOR YOUR PROTECTION AGAINST SHOCK HAZARD AND SHOULD BE PLUGGED DIRECTLY INTO A PROPERLY GROUNDED THREE-PRONG RECEPTACLE. Do not cut or remove the grounding prong from the plug.











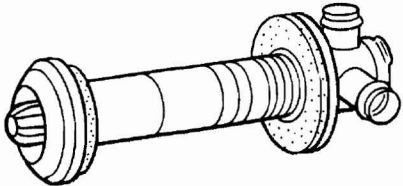

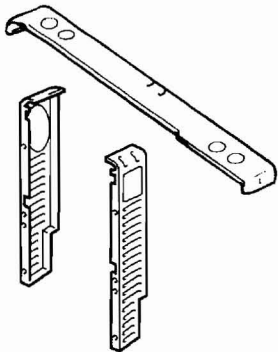

This gas appliance must not be connected to a chimney flue serving a separate solid-fuel burning appliance.

When the appliance is installed directly on carpeting, tile or other combustible material other than wood flooring, the appliance shall be installed on a metal or wood panel extending the full width and depth of the appliance.

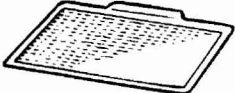
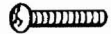
Rinnai recommends a dedicated electrical circuit.

Appliance input ratings are based on sea level operation and need not be changed for operation up to 2,000 feet elevation. For operation at elevations above 2,000 feet, manufactured to specified deration conditions for Canada and the United States.

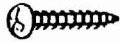
INSTALLATION INSTRUCTIONS

Flue Manifold1		Spare rubber seal1 (‘A’ Flue units only)			
		 (For weatherboard installations)			
Back Spacer Set		1	Flue Locking Clamp		1
			Flue Lock Stopper		1
			Insulation Clip		1
			Hose Clip		2
Customers operating information and Installation Instructions		1	Plastic tie for air inlet		1
Air Filter		1	(M4X20)	 For Flue Lock Stopper	1
(M4)	 For Back Spacer Set	6	(M4)	 For Flue Manifold	3
(M4)	 For Air Intake Clip	2	(M4.8X32) Wood Screws	 Wall Bracket Screws	5
Wall Bracket		1	Spacer Bracket		1

Check to ensure gas supply matches that of the appliance.
Refer to local gas authority for confirmation of gas type if in doubt.
Refer to data plate located inside of the front panel.
Check for damage, if the unit is damaged contact your supplier or Rinnai.
Do not install a damaged unit before checking with your supplier.
Refer to an approved pipe sizing chart if in doubt about size of gas line.

GAS CONNECTION

1. The gas supply line shall be gas-tight, sized and so installed as to provide a supply of gas sufficient to meet the maximum demand of the heater without loss of pressure.
2. A shut off valve (and appliance connector valve) should be installed in the upstream of the gas line to permit servicing.
3. Flexible pipe and any appliance connector valve used for gas piping shall be types approved by nationally recognized agencies.
4. Any compound used on the threaded joint of the gas piping shall be a type which resists the action of liquefied petroleum gas.
5. Supplied gas pressure must be within the limits shown in the specifications.
6. After completion of gas pipe connections, all joints including the heater must be checked for gas tightness by means of leak detector solution, soap and water, or an equivalent nonflammable solution, as applicable.

CAUTION: Since some leak test solutions, including soap and water, may cause corrosion or stress cracking, the piping shall be rinsed with water after testing, unless it has been determined that the leak test solution is noncorrosive.

7. The appliance and its appliance main gas valve must be disconnected from the gas supply piping system during any pressure testing of that system at test pressures in excess of 1/2 P.S.I (3.5kPa).

The appliance must be isolated from the gas supply piping system by closing its individual manual shut off valve during any pressure testing of the gas supply system at test pressures equal to or less than 1/2 psig.

8. Two 1/8" test plugs are provided for testing of manifold pressure see schematic for location.

At time of installation installer must supply a 1/8" N.P.T. plugged tapping, accessible for test manometer connection, immediately up stream of the gas supply connection to the appliance.

THIS IS NOT A BOUNDARY SURVEY

MORTGAGE INSPECTION OF: DEED BOOK 9057 PAGE 217 COUNTY Cumberland
PLAN BOOK 10 PAGE 91 LOT 135

ADDRESS: 18-20 Presumpscot Street, Portland, Maine

Job Number: 490-50

Buyers: James R. & David A. Giroux

Inspection Date: 8-27-04

Scale: 1" = 60'

Sellers: Rocco & Giovina Ferrante

Client File#: 41033

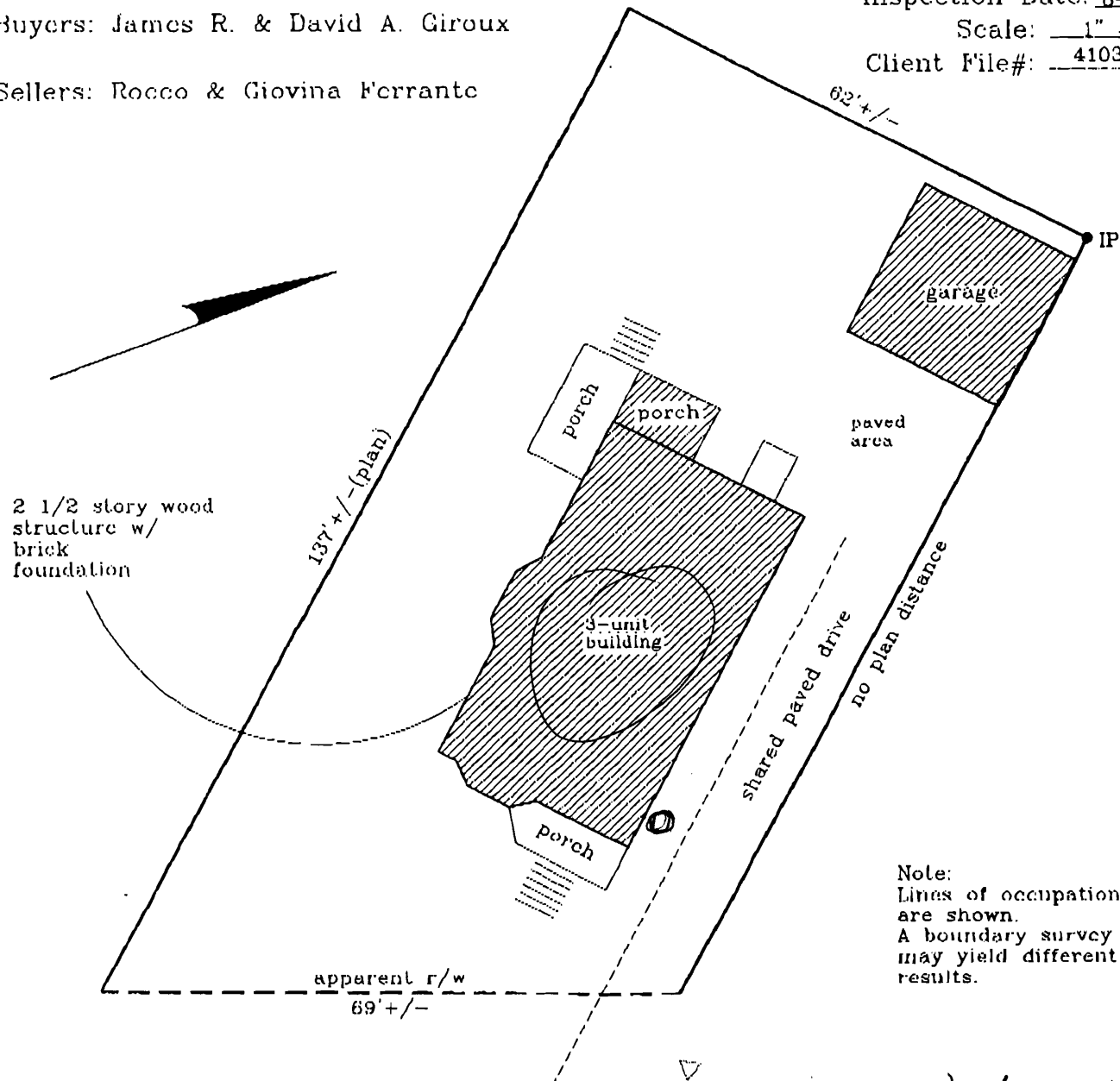

Note:
Lines of occupation are shown.
A boundary survey may yield different results.

to Washington Ave.

Presumpscot Street

I HEREBY CERTIFY TO: Bay Area Title Services, Inc; First Horizon Home Loan Corp. and its title insurer.

Monuments found did not conflict with the deed description.
The dwelling setbacks do not violate town zoning requirements.

As delineated on the Federal Emergency Management Agency Community Panel: 230051 0007 C

The structure does not fall within the special flood hazard zone.

The land does not fall within the special flood hazard zone.

A wetlands study has not been performed.

APPARENT EASEMENTS AND RIGHTS OF WAY ARE SHOWN. OTHER ENCUMBRANCES, RECORDED OR NOT, MAY EXIST. THIS SKETCH WILL NOT REVEAL ABUTTING DEED CONFLICTS, IF ANY.

copyright 1994

Livingston - Hughes

Professional Land Surveyors

88 Guinea Road

Kennebunkport - Maine 04046

207 967 9761 phone 207-967-4831 fax

THIS SKETCH IS FOR MORTGAGE PURPOSES ONLY