

DISPLAY THIS CARD ON PRINCIPAL FRONTAGE OF WORK



CITY OF PORTLAND BUILDING PERMIT



This is to certify that

HODGINS STREET PROPERTIES LLC /Gelinas HVAC
Services Inc.

PERMIT ID: 2013-00080

Located at

48 HODGINS ST

CBL: 427 G003001

has permission to **Install Carlin EZ Gas Burner in basement**

provided that the person or persons, firm or corporation accepting this permit shall comply with all of the provisions of the Statues of Maine and of the Ordinances of the City of Portland regulating the construction, maintenance and use of the buildings and structures, and of the application on file in the department.

Notification of inspection and written permission procured before this building or part thereof is lathed or otherwise closoed-in. 48 HOUR NOTICE IS REQUIRED.

A final inspection must be completed by owner before this building or part thereof is occupied. If a certificate of occupancy is required, it must be procured prior to occupancy.

Fire Prevention Officer

01/16/13

Code Enforcement Officer / Plan Reviewer

**THIS CARD MUST BE POSTED ON THE STREET SIDE OF THE PROPERTY
THERE IS A PENALTY FOR REMOVING THIS CARD**

BUILDING PERMIT INSPECTION PROCEDURES
Please call 874-8703 (ONLY)
or email: buildinginspections@portlandmaine.gov

With the issuance of this permit, the owner, builder or their designee is required to provide adequate notice to the city of Portland Inspections Services for the following inspections. Appointments must be requested 48 to 72 hours in advance of the required inspection. The inspection date will need to be confirmed by this office.

- **Please read the conditions of approval that is attached to this permit!! Contact this office if you have any questions.**
- **Permits expire in 6 months. If the project is not started or ceases for 6 months.**
- **If the inspection requirements are not followed as stated below additional fees may be incurred due to the issuance of a "Stop Work Order" and subsequent release to continue.**

REQUIRED INSPECTIONS:

Close-in/Elec./Plmb./Framing
Final Inspection

The project cannot move to the next phase prior to the required inspection and approval to continue, REGARDLESS OF THE NOTICE OF CIRCUMSTANCES.

IF THE PERMIT REQUIRES A CERTIFICATE OF OCCUPANCY, IT MUST BE PAID FOR AND ISSUED TO THE OWNER OR DESIGNEE BEFORE THE SPACE MAY BE OCCUPIED.

City of Portland, Maine - Building or Use Permit

389 Congress Street, 04101 Tel: (207) 874-8703, Fax: (207) 874-8716

Permit No: 2013-00080	Date Applied For: 01/14/2013	CBL: 427 G003001
---------------------------------	--	----------------------------

Location of Construction: 48 HODGINS ST	Owner Name: HODGINS STREET PROPERTIES	Owner Address: PO BOX 8249	Phone:
Business Name:	Contractor Name: Gelinac HVAC Services Inc.	Contractor Address: 2 Washington Ave Scarborough	Phone (207) 885-0771
Lessee/Buyer's Name	Phone:	Permit Type: HVAC	

Proposed Use: Two Family	Proposed Project Description: Install Carlin EZ Gas Burner in basement
------------------------------------	--

Dept: Zoning **Status:** Approved w/Conditions **Reviewer:** Ann Machado **Approval Date:** 01/15/2013

Note: **Ok to Issue:**

- 1) This property shall remain a two family dwelling. Any change of use shall require a separate permit application for review and approval.

Dept: Building **Status:** Approved w/Conditions **Reviewer:** Jon Rioux **Approval Date:** 01/16/2013

Note: **Ok to Issue:**

- 1) The installation must comply with UL, the Manufacturers' Listing, MUBEC (IRC, 2009), and State of Maine Gas Regulations. Separate permits are required for any electrical: plumbing, sprinkler, fire alarm, HVAC systems, commercial hood exhaust systems and fuel tanks. Separate plans may need to be submitted for approval as a part of this process. Maintain proper setback(s) from property lines/buildings and proper clearances from vertical openings when direct venting. A Carbon Monoxide (CO) alarm shall be installed in each area within or giving access to bedrooms. That detection must be powered by the electrical service (plug-in or hardwired) in the building and battery. R302.4 Dwelling unit rated penetrations. Penetrations of wall or floor/ceiling assemblies required to be fire-resistance rated in accordance with Section R302.2 or R302.3 shall be protected in accordance with this section.

City of Portland, Maine - Building or Use Permit Application

389 Congress Street, 04101 Tel: (207) 874-8703, Fax: (207) 874-8716

Permit No: 2013-00080	Issue Date:	CBL: 427 G003001
--------------------------	-------------	---------------------

Location of Construction: 48 HODGINS ST	Owner Name: HODGINS STREET PROPERTIES LLC	Owner Address: PO BOX 8249 PORTLAND, ME 04104	Phone:
Business Name:	Contractor Name: Gelinac HVAC Services Inc.	Contractor Address: 2 Washington Ave Scarborough ME 04074	Phone (207) 885-0771
Lessee/Buyer's Name	Phone:	Permit Type: HVAC	Zone: R5
Past Use: Two Family	Proposed Use: Two Family	Permit Fee: \$70.00	Cost of Work: \$4,500.00
Proposed Project Description: Install Carlin EZ Gas Burner (basement)		FIRE DEPT: <input type="checkbox"/> Approved <input type="checkbox"/> Denied <input checked="" type="checkbox"/> N/A	INSPECTION: Use Group: Type: ME Gas (MURSEC) Rogs HUAC
		Signature: _____ Signature: _____	
PEDESTRIAN ACTIVITIES DISTRICT (P.A.D.)			
Action: <input type="checkbox"/> Approved <input type="checkbox"/> Approved w/Conditions <input type="checkbox"/> Denied			
Signature: _____ Date: _____			

Permit Taken By: gg	Date Applied For: 01/14/2013	Zoning Approval		
<ol style="list-style-type: none"> This permit application does not preclude the Applicant(s) from meeting applicable State and Federal Rules. Building permits do not include plumbing, septic or electrical work. Building permits are void if work is not started within six (6) months of the date of issuance. False information may invalidate a building permit and stop all work.. 		Special Zone or Reviews <input type="checkbox"/> Shoreland <input type="checkbox"/> Wetland <input type="checkbox"/> Flood Zone <input type="checkbox"/> Subdivision <input type="checkbox"/> Site Plan Maj <input type="checkbox"/> Minor <input type="checkbox"/> MM <input type="checkbox"/> Date: 1/15/13 ABM	Zoning Appeal <input type="checkbox"/> Variance <input type="checkbox"/> Miscellaneous <input type="checkbox"/> Conditional Use <input type="checkbox"/> Interpretation <input type="checkbox"/> Approved <input type="checkbox"/> Denied Date:	Historic Preservation <input checked="" type="checkbox"/> Not in District or Landmark <input type="checkbox"/> Does Not Require Review <input type="checkbox"/> Requires Review <input type="checkbox"/> Approved <input type="checkbox"/> Approved w/Conditions <input type="checkbox"/> Denied Date: ABM

CERTIFICATION

I hereby certify that I am the owner of record of the named property, or that the proposed work is authorized by the owner of record and that I have been authorized by the owner to make this application as his authorized agent and I agree to conform to all applicable laws of this jurisdiction. In addition, if a permit for work described in the application is issued, I certify that the code official's authorized representative shall have the authority to enter all areas covered by such permit at any reasonable hour to enforce the provision of the code(s) applicable to such permit.

SIGNATURE OF APPLICANT	ADDRESS	DATE	PHONE
RESPONSIBLE PERSON IN CHARGE OF WORK, TITLE		DATE	PHONE

1-18-13 DWM Final OK



MODEL **EZ-Gas™**
Gas burner

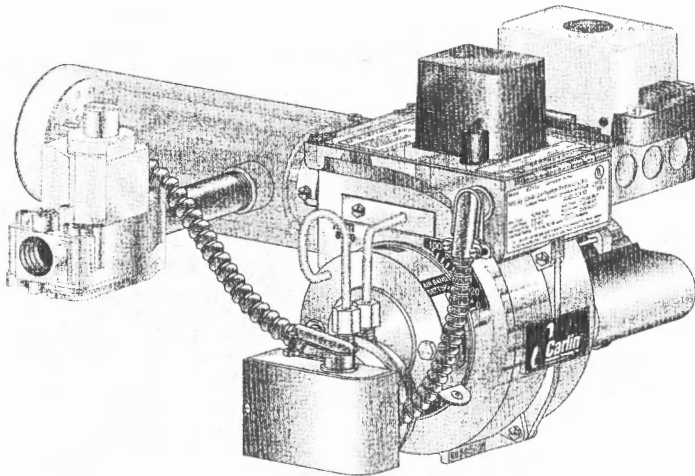

Instruction manual

Ratings

Input: 50,000 to 275,000 Btuh
Fuels: Natural gas or propane gas
	Max. supply pressure..... 14 inches w.c.
	Min. supply pressure..... 5 inches w.c.
	Manifold pressure 3.5 inches w.c.
Electrical:	Power..... 120V/60 Hz/1-Phase
	Motor..... 1/15, 1/7, or 1/6 HP, 3450 RPM
	Current..... Approx. 2.0, 2.5 or 2.3 amps
Ignition: Carlin Model 41800 solid state ignitor
Control: Carlin Model 60200FR microprocessor control
Agencies: UL Listed (US and Canada)



WARNING **Installer/servicer** — Except where specifically stated otherwise, this manual must be used only by a **qualified service technician**. (In the state of Massachusetts, this product must be installed by a licensed Plumber or Gas Fitter.) Failure to comply with this or other requirements in this manual could result in severe personal injury, death or substantial property damage.

WARNING **User** — Refer only to **User's Information** manual for information regarding operation of this burner. The burner **Instruction Manual** is intended only for your service technician. The burner and heat exchanger must be inspected and started at least annually by your service technician.

Contents

PLEASE read this first.....	2
Codes and standards.....	2
EZ-Gas burner at-a-glance.....	3
Prepare site • prepare burner • mount burner	4
Install gas piping	9
Wire burner.....	10
Check system • start-up burner/appliance.....	11
Perform checkout procedure • fill out certificate	14
Maintenance and service procedures.....	16
Troubleshooting.....	17
Dimensions and mounting information	19
Replacement parts.....	20

© Copyright 2008 — Carlin Combustion Technology, Inc.

Carlin Combustion Technology, Inc.

70 Maple Street
Ph 413-525-7700

East Longmeadow, MA 01028
Fx 413-525-8306

TECH SUPPORT 800-989-2275

carlincombustion.com

When appliance instructions differ from this manual, follow the appliance instructions.

1. Prepare site • prepare burner • mount burner (continued)

Inspect installation site

Verify combustion/ventilation air openings

WARNING Installing the burner/appliance in a space that does not provide enough air for combustion and ventilation can result in severe personal injury, death or substantial property damage. Follow all applicable codes and guidelines below to ensure space has sufficient air openings.

Large spaces

For appliances located in basements, ventilated crawl spaces or other large areas, no additional air openings should be necessary. Exception: If the building construction is unusually tight (see National Fuel Gas Code for definition), you will need to provide air openings into the building if appliance air comes from inside. Provide one opening within 12 inches of the ceiling, and one opening within 12 inches of the floor. Size each opening to provide free area (after deduction for louvers) of 1 square inch per 1,000 Btuh input of all fuel-burning appliances in the building.

Confined spaces — air from inside building

If air openings connect to areas inside the building, provide two openings, one within 12 inches of the ceiling, the other within 12 inches of the floor. Each opening must have a free area (after deduction for louvers) of 1 square inch per 1,000 Btuh of all appliances in the space. If the building construction is unusually tight (see National Fuel Gas Code for definition), you will need to provide air openings into the building. Provide two openings sized and located as for the openings into the boiler space.

Confined spaces — air from outside

If air openings connect directly to outside, provide two openings, one within 12 inches of the ceiling, the other within 12 inches of the floor. Each opening must have a free area (after louver deduction) of:

- If directly through side wall: 1 square inch for each 4,000 Btuh of all appliances in the space.
- If through vertical ducts: 1 square inch for each 4,000 Btuh of all appliances in the space.
- If through horizontal ducts: 1 square inch for each 2,000 Btuh of all appliances in the space.

Optional air inlet boot

For spaces not fitted with large enough air openings, you may be able to apply the optional Inlet air boot, with air ducted directly to the air boot from outside. You must use a vent outlet/air inlet termination approved by the appliance manufacturer. Refer to the appliance instructions and Inlet air boot instructions for correct application.

You will also have to apply this option if the appliance space may contain corrosive contaminants, such as laundry products, paints, varnishes or other chemicals.

WARNING Even when using the optional Inlet air boot, make sure the space provides enough ventilation to prevent overheating of the appliance, burner and controls. If there is risk of overheating, you must install ventilation air openings sized large enough to provide air for cooling the equipment. Failure to provide ventilation can result in severe personal injury, death or substantial property damage.

Figure 2 Locating & sizing air openings

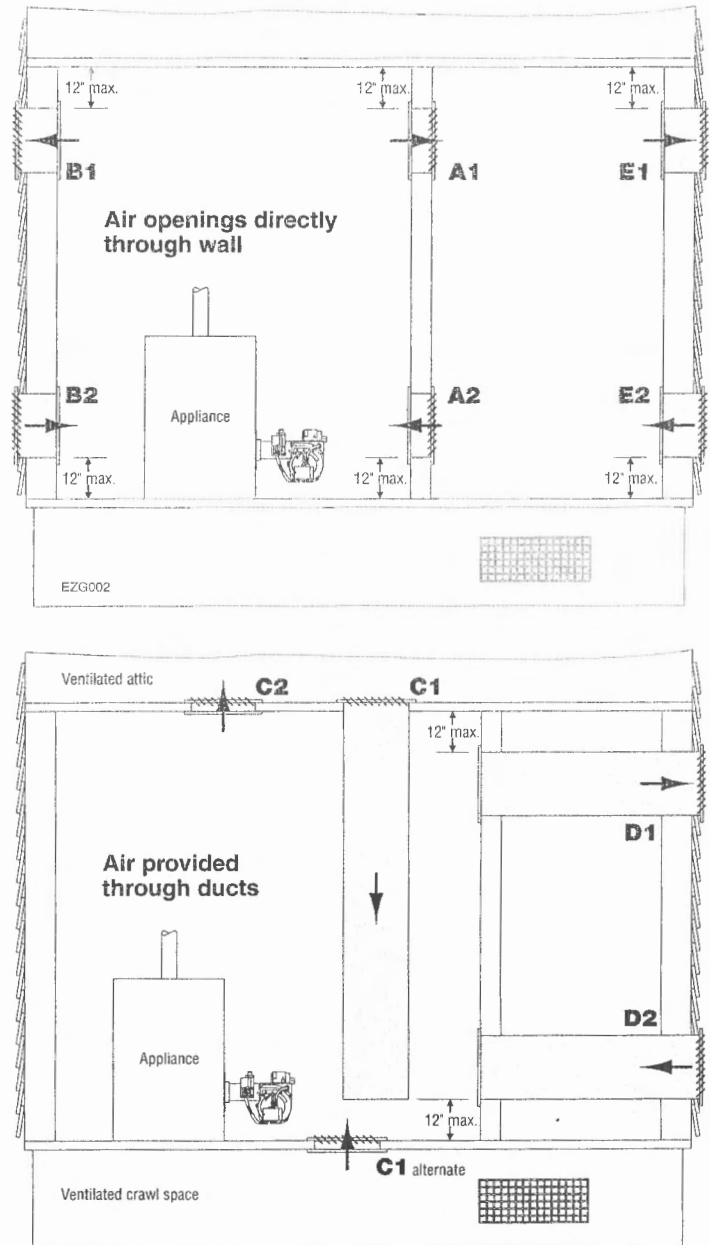

Minimum grille free area per 1,000 Btuh input of all appliances in space

A1 & 2	Two openings through interior wall	1 sq. in.
B1 & 2	Two openings through outside wall	0.25 sq. in.
C1 & 2	Two vertical ducts (to attic and crawl space)	0.25 sq. in.
D1 & 2	Two horizontal ducts from outside	0.50 sq. in.
E1 & 2	If building construction is unusually tight, provide two air openings as shown if appliance air comes from inside.	1 sq. in.

Example A space contains two fuel-burning appliances. The combined input is 120,000 Btuh. Air comes in through horizontal ducts from outside. This is case D. So multiply 0.50 sq. in. times 120 to get 60 sq. in. free area per opening. If louvers reduce free area to 70%, then divide minimum free area by 0.7 for actual grille area, or $60 \div 0.7 = 85.7$ sq. in.

1. Prepare site • prepare burner • mount burner (continued)

Inspect installation site

Verify combustion/ventilation air openings

WARNING Installing the burner/appliance in a space that does not provide enough air for combustion and ventilation can result in severe personal injury, death or substantial property damage. Follow all applicable codes and guidelines below to ensure space has sufficient air openings.

Large spaces

For appliances located in basements, ventilated crawl spaces or other large areas, no additional air openings should be necessary. Exception: If the building construction is unusually tight (see National Fuel Gas Code for definition), you will need to provide air openings into the building if appliance air comes from inside. Provide one opening within 12 inches of the ceiling, and one opening within 12 inches of the floor. Size each opening to provide free area (after deduction for louvers) of 1 square inch per 1,000 Btuh input of all fuel-burning appliances in the building.

Confined spaces — air from inside building

If air openings connect to areas inside the building, provide two openings, one within 12 inches of the ceiling, the other within 12 inches of the floor. Each opening must have a free area (after deduction for louvers) of 1 square inch per 1,000 Btuh of all appliances in the space. If the building construction is unusually tight (see National Fuel Gas Code for definition), you will need to provide air openings into the building. Provide two openings sized and located as for the openings into the boiler space.

Confined spaces — air from outside

If air openings connect directly to outside, provide two openings, one within 12 inches of the ceiling, the other within 12 inches of the floor. Each opening must have a free area (after louver deduction) of:

- If directly through side wall: 1 square inch for each 4,000 Btuh of all appliances in the space.
- If through vertical ducts: 1 square inch for each 4,000 Btuh of all appliances in the space.
- If through horizontal ducts: 1 square inch for each 2,000 Btuh of all appliances in the space.

Optional air inlet boot

For spaces not fitted with large enough air openings, you may be able to apply the optional Inlet air boot, with air ducted directly to the air boot from outside. You must use a vent outlet/air inlet termination approved by the appliance manufacturer. Refer to the appliance instructions and Inlet air boot instructions for correct application.

You will also have to apply this option if the appliance space may contain corrosive contaminants, such as laundry products, paints, varnishes or other chemicals.

WARNING Even when using the optional Inlet air boot, make sure the space provides enough ventilation to prevent overheating of the appliance, burner and controls. If there is risk of overheating, you must install ventilation air openings sized large enough to provide air for cooling the equipment. Failure to provide ventilation can result in severe personal injury, death or substantial property damage.

Figure 2 Locating & sizing air openings

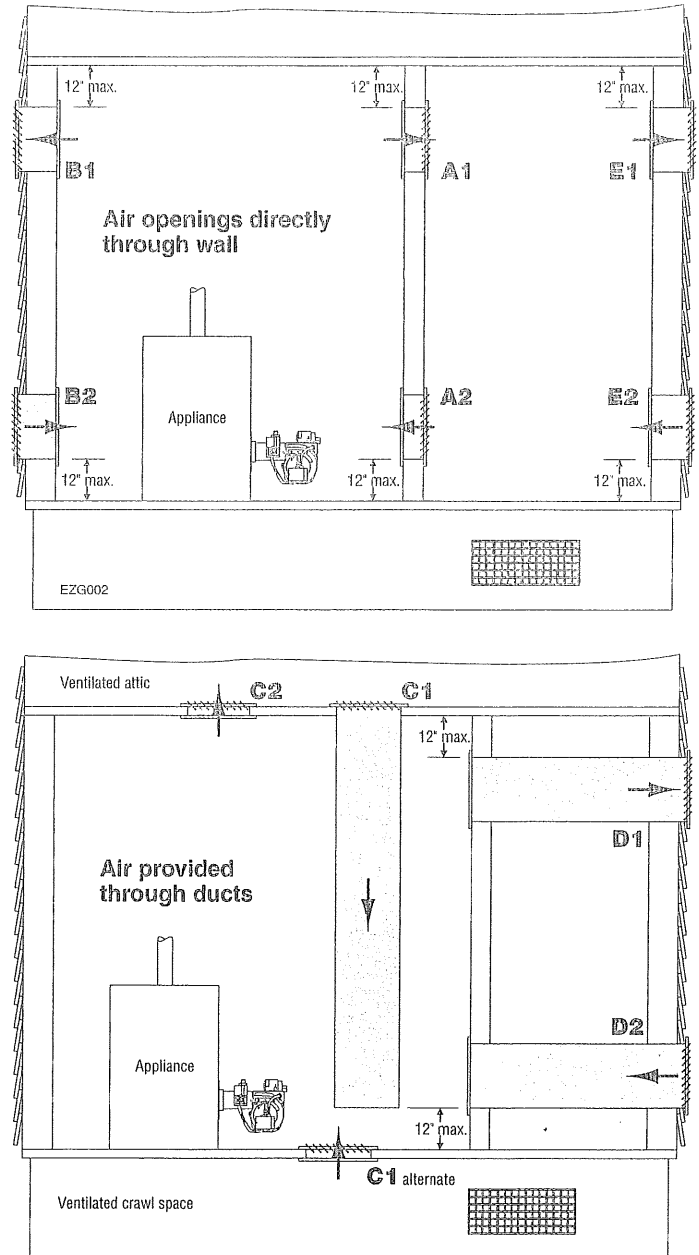

Minimum grille free area per 1,000 Btuh input of all appliances in space

A1 & 2	Two openings through interior wall	1 sq. in.
B1 & 2	Two openings through outside wall	0.25 sq. in.
C1 & 2	Two vertical ducts (to attic and crawl space)	0.25 sq. in.
D1 & 2	Two horizontal ducts from outside	0.50 sq. in.
E1 & 2	If building construction is unusually tight, provide two air openings as shown if appliance air comes from inside.	1 sq. in.

Example A space contains two fuel-burning appliances. The combined input is 120,000 Btuh. Air comes in through horizontal ducts from outside. This is case D. So multiply 0.50 sq. in. times 120 to get 60 sq. in. free area per opening. If louvers reduce free area to 70%, then divide minimum free area by 0.7 for actual grille area, or $60 \div 0.7 = 85.7$ sq. in.