

DISPLAY THIS CARD ON PRINCIPAL FRONTAGE OF WORK



# CITY OF PORTLAND

# BUILDING PERMIT

This is to certify that MADALYN F PAIGE HEIRS

Located At 72 WORDSWORTH ST

Job ID: 2012-05-3889-HVAC

CBL: 426- B-020-001

has permission to install an after-the-fact HVAC system (Single Family Residence).

provided that the person or persons, firm or corporation accepting this permit shall comply with all of the provisions of the Statues of Maine and of the Ordinances of the City of Portland regulating the construction, maintenance and use of the buildings and structures, and of the application on file in the department.

Notification of inspection and written permission procured before this building or part thereof is lathed or otherwise closed-in. 48 HOUR NOTICE IS REQUIRED.

A final inspection must be completed by owner before this building or part thereof is occupied. If a certificate of occupaney is required, it must be

**Fire Prevention Officer**

  
**Code Enforcement Officer / Plan Reviewer**

05/04/2012

THIS CARD MUST BE POSTED ON THE STREET SIDE OF THE PROPERTY

PENALTY FOR REMOVING THIS CARD

## BUILDING PERMIT INSPECTION PROCEDURES

Please call 874-8703 or 874-8693 (ONLY)

or email: [buildinginspections@portlandmaine.gov](mailto:buildinginspections@portlandmaine.gov)

With the issuance of this permit, the owner, builder or their designee is required to provide adequate notice to the city of Portland Inspections Services for the following inspections. Appointments must be requested 48 to 72 hours in advance of the required inspection. The inspection date will need to be confirmed by this office.

- **Please read the conditions of approval that is attached to this permit!! Contact this office if you have any questions.**
- **Permits expire in 6 months. If the project is not started or ceases for 6 months.**
- **If the inspection requirements are not followed as stated below additional fees may be incurred due to the issuance of a "Stop Work Order" and subsequent release to continue.**

### 1. Final Inspection (After-the-Fact)

The project cannot move to the next phase prior to the required inspection and approval to continue, REGARDLESS OF THE NOTICE OF CIRCUMSTANCES.

IF THE PERMIT REQUIRES A CERTIFICATE OF OCCUPANCY, IT MUST BE PAID FOR AND ISSUED TO THE OWNER OR DESIGNEE BEFORE THE SPACE MAY BE OCCUPIED.



# PORTLAND MAINE

*Strengthening a Remarkable City, Building a Community for Life • [www.portlandmaine.gov](http://www.portlandmaine.gov)*

Acting Director of Planning and Urban Development  
Gregory Mitchell

Job ID: 2012-05-3889-HVAC

Located At: 72 WORDSWORTH  
ST

CBL: 426- B-020-001

## Conditions of Approval:

### **Building**

1. The installation must comply with UL, the Manufacturers' Listing, MUBEC (IRC, 2009), and State of Maine Gas Regulations.
2. Separate permits are required for any electrical: plumbing, sprinkler, fire alarm, HVAC systems, commercial hood exhaust systems and fuel tanks. Separate plans may need to be submitted for approval as a part of this process.
3. Maintain proper setback(s) from property lines/buildings and proper clearances from vertical openings when direct venting
4. A Carbon Monoxide (CO) alarm shall be installed in each area within or giving access to bedrooms. That detection must be powered by the electrical service (plug-in or hardwired) in the building and battery.
5. M1804.2.5 Direct vent terminations. Vent terminals for direct-vent appliances shall be installed in accordance with the manufacturer's installation instructions.

**City of Portland, Maine - Building or Use Permit Application**

389 Congress Street, 04101 Tel: (207) 874-8703, FAX: (207) 8716

Job No: 2012-05-3889-HVAC	Date Applied: 5/1/2012	CBL: 426- B-020-001	
Location of Construction: 72 WORDSWORTH ST	Owner Name: MADALYN F PAIGE HEIRS	Owner Address: 72 WORDSWORTH ST PORTLAND, ME 04103	Phone:
Business Name:	Contractor Name: P & P Plumbing & Heating	Contractor Address: 24 Caddie Lane, Portland, ME 04103	Phone: (207) 797-3100
Lessee/Buyer's Name:	Phone:	Permit Type: HVAC - HVAC	Zone: R-5
Past Use: Single family	Proposed Use: Same - Single family - permit Baxi Luna Wall Hung unit	Cost of Work: 6000.00	CEO District:
		Fire Dept: <input type="checkbox"/> Approved <input type="checkbox"/> Denied <input type="checkbox"/> N/A	Inspection: Use Group: R3 Type: SB Maine Gos Regs (NUBAC) Signature: <i>[Signature]</i>
Proposed Project Description: install Baxi Luna wall hung (after the fact)		Pedestrian Activities District (P.A.D.)	

Permit Taken By:	<b>Zoning Approval</b>		
<p>1. This permit application does not preclude the Applicant(s) from meeting applicable State and Federal Rules.</p> <p>2. Building Permits do not include plumbing, septic or electrical work.</p> <p>3. Building permits are void if work is not started within six (6) months of the date of issuance. False information may invalidate a building permit and stop all work.</p>	<p><b>Special Zone or Reviews</b></p> <p><input type="checkbox"/> Shoreland</p> <p><input type="checkbox"/> Wetlands</p> <p><input type="checkbox"/> Flood Zone</p> <p><input type="checkbox"/> Subdivision</p> <p><input type="checkbox"/> Site Plan</p> <p><input type="checkbox"/> Maj <input type="checkbox"/> Min <input type="checkbox"/> MM</p> <p>Date: <i>OK 5/2/12</i></p>	<p><b>Zoning Appeal</b></p> <p><input type="checkbox"/> Variance</p> <p><input type="checkbox"/> Miscellaneous</p> <p><input type="checkbox"/> Conditional Use</p> <p><input type="checkbox"/> Interpretation</p> <p><input type="checkbox"/> Approved</p> <p><input type="checkbox"/> Denied</p> <p>Date:</p>	<p><b>Historic Preservation</b></p> <p><input checked="" type="checkbox"/> Not in Dist or Landmark</p> <p><input type="checkbox"/> Does not Require Review</p> <p><input type="checkbox"/> Requires Review</p> <p><input type="checkbox"/> Approved</p> <p><input type="checkbox"/> Approved w/Conditions</p> <p><input type="checkbox"/> Denied</p> <p>Date: <i>ASN</i></p>
	<b>CERTIFICATION</b>		

I hereby certify that I am the owner of record of the named property, or that the proposed work is authorized by the owner of record and that I have been authorized by the owner to make this application as his authorized agent and I agree to conform to all applicable laws of this jurisdiction. In addition, if a permit for work described in the application is issued, I certify that the code official's authorized representative shall have the authority to enter all areas covered by such permit at any reasonable hour to enforce the provision of the code(s) applicable to such permit.

SIGNATURE OF APPLICANT	ADDRESS	DATE	PHONE
RESPONSIBLE PERSON IN CHARGE OF WORK, TITLE		DATE	PHONE



FILL IN AND SIGN WITH INK

# APPLICATION FOR PERMIT HEATING OR POWER EQUIPMENT

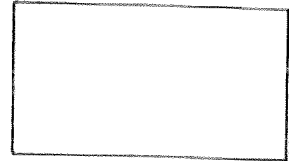

To the INSPECTOR OF BUILDINGS, PORTLAND, ME.

The undersigned hereby applies for a permit to install the following heating, cooking or power equipment in accordance with the Laws of Maine, the Building Code of the City of Portland, and the following specifications:

Location / CBI. 72 Wordsworth St <sup>Portland</sup> ME Use of Building Residential Date 4/30/2012  
 Name and address of owner of appliance Thomas M Paige PR For Estate of  
Madelyn F Paige  
 Installer's name and address DTP Plumbing + Heating  
24 Caddie Lane Portland ME 04103 Telephone 797-3100

**Location of appliance:**

- Basement
- Attic
- Floor
- Roof

**Type of Fuel:**

- Gas
- Oil
- Solid

Appliance Name: Bexi Luna O-310

U.L. Approved  Yes  No

Will appliance be installed in accordance with the manufacture's installation instructions?  Yes  No

IF NO Explain: \_\_\_\_\_

**The Type of License of Installer:**

- Master Plumber # MS90008367
- Solid Fuel # \_\_\_\_\_
- Oil # \_\_\_\_\_
- Gas # PNT 1284
- Other \_\_\_\_\_

**Type of Chimney:**

- Masonry Lined  
Factory built \_\_\_\_\_
- Metal  
Factory Built U.L. Listing # \_\_\_\_\_
- Direct Vent  
Type Coaxial/Dual Ave U.L.# \_\_\_\_\_

**Type of Fuel Tank**

- Oil
- Gas Natural

Size of Tank \_\_\_\_\_

Number of Tanks \_\_\_\_\_

Distance from Tank to Center of Flame \_\_\_\_\_ feet.

Cost of Work: \$ 5200.00

Permit Fee: \$ \_\_\_\_\_

**Approved**

Fire: \_\_\_\_\_

Ele.: \_\_\_\_\_

Bldg.: \_\_\_\_\_

**Approved with Conditions**

- See attached letter or requirement

Inspector's Signature \_\_\_\_\_

Date Approved \_\_\_\_\_

Signature of Installer Stephane...

White - Inspection    Yellow - File    Pink - Applicant's    Gold - Assessor's Copy

R-5



FILL IN AND SIGN WITH INK

# APPLICATION FOR PERMIT HEATING OR POWER EQUIPMENT

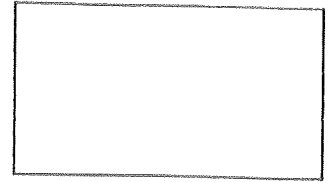

406 B 020 2012 05 3889

To the INSPECTOR OF BUILDINGS, PORTLAND, ME.

The undersigned hereby applies for a permit to install the following heating, cooking or power equipment in accordance with the Laws of Maine, the Building Code of the City of Portland, and the following specifications:

Location / CBL 72 Woodsworth St <sup>Portland</sup> ME Use of Building Residential Date 4/30/2012  
 Name and address of owner of appliance Thomas M Paige Cell-831-8296-Home(892-5570)  
77 Evergreen Lane Windham ME 04062  
 Installer's name and address Pt P Plumbing + Heating  
24 Caddie Lane Portland ME 04103 Telephone 797-3100

### Location of appliance:

- Basement  Floor
- Attic  Roof

### Type of Fuel:

- Gas  Oil  Solid

Appliance Name: Baxi Luna Wall hung  
 U.L. Approved  Yes  No 130,000 BTU

Will appliance be installed in accordance with the manufacture's installation instructions?  Yes  No

IF NO Explain: \_\_\_\_\_

### The Type of License of Installer:

- Master Plumber # PNT 3902
- Solid Fuel # \_\_\_\_\_
- Oil # \_\_\_\_\_
- Gas # \_\_\_\_\_
- Other \_\_\_\_\_

### Type of Chimney:

- Masonry Lined  
Factory built \_\_\_\_\_
- Metal  
Factory Built U.L. Listing # \_\_\_\_\_

Direct Vent  
Type \_\_\_\_\_

### Type of Fuel Tank

- Oil
- Gas

Size of Tank \_\_\_\_\_

Number of Tanks \_\_\_\_\_

Distance from Tank to Center of Flame \_\_\_\_\_ feet.

Cost of Work: \$ 5200.00

Permit Fee: \$ \_\_\_\_\_

RECEIVED  
 MAY 01 2012  
 Dept. of Building Inspections  
 City of Portland Maine  
 ASKED  
 The  
 Fac  
 Closing May 18th

DENIED

### Approved

### Approved with Conditions

Fire: \_\_\_\_\_

Ele.: \_\_\_\_\_

Bldg.: \_\_\_\_\_

See attached letter or requirement

Inspector's Signature

Date Approved

Signature of Installer Thomas M Paige (Owner)

White - Inspection    Yellow - File    Pink - Applicant's    Gold - Assessor's Copy

1. Locate the flue elbow on the adaptor at the top of the boiler. Set the elbow to the required orientation (rear, right or left).
2. Measure the distance from the outside wall face to the elbow (Fig. 3). This dimension will be known as 'X'.
3. Taking the, mark dimension 'X' as shown (Fig. 4). Measure the length of waste material, and transfer the dimension to the flue duct (Fig. 4).
4. Remove the waste from both. Ensure that the cut ends are square and free from burrs.
5. Remove the flue elbow from the adaptor.

**IMPORTANT:** Check all measurements before cutting. Clearance to combustible materials when using concentric system is zero.

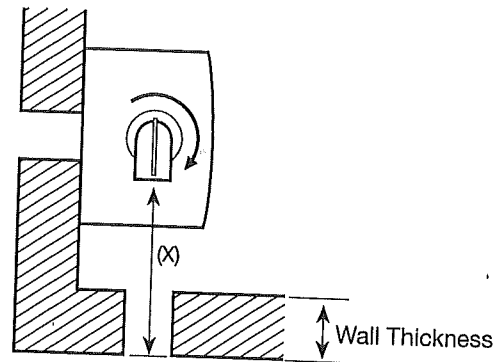
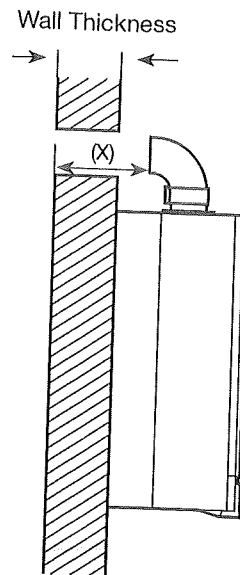
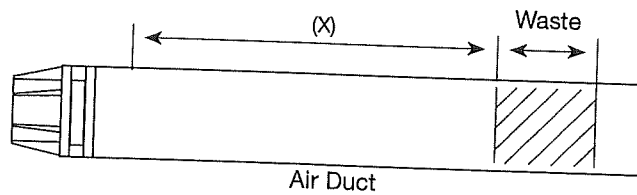

Fig. 3



Air Duct

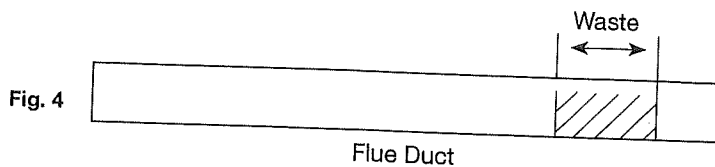

Fig. 4

Flue Duct

## 2. TECHNICAL DATA

### 2.1 PERFORMANCE

Central Heating		MAX		MIN
Altitude	Ft	0÷2000	2000÷4500	
	m	0÷610	610÷1370	
Heat Input (Gross)	Btu/h	126 249	120 107	45 040
	kW	37	35.2	13.2
Heat Output (modulating)	Btu/h	105 776	100 658	35 486
	kW	31	29.5	10.4
Burner Pressure Setting natural gas (A)	w.c.	5.6	5.2	0.7
	mbar	14.0	12.8	1.8
Gas Rate natural gas (A)	ft <sup>3</sup> /h	124.2	118.2	44.5
	m <sup>3</sup> /h	3.52	3.35	1.26
Burner Pressure Setting LP gas (E)	w.c.	9.8	9.3	1.3
	mbar	24.4	23.0	3.3
Gas Rate LP gas (E)	ft <sup>3</sup> /h	49.0	46.6	17.29
	m <sup>3</sup> /h	1.39	1.32	0.49
CH Water Temp. (Approx.)	°F	185		
	°C	85		

table 1

Domestic Hot Water		MAX		MIN
Altitude	Ft	0÷2000	2000÷4500	
	m	0÷610	610÷1370	
Heat Input (Gross)	Btu/h	126 249	120 107	45 040
	kW	37	35.2	13.2
Heat Output (modulating)	Btu/h	105 776	100 658	35 486
	kW	31	29.5	10.4
Burner Pressure Setting natural gas (A)	w.c.	5.6	5.1	0.7
	mbar	14.0	12.8	1.8
Gas Rate natural gas (A)	ft <sup>3</sup> /h	124.2	118.2	44.5
	m <sup>3</sup> /h	3.52	3.35	1.26
Burner Pressure Setting LP gas (E)	w.c.	9.8	9.3	1.3
	mbar	24.4	23.0	3.3
Gas Rate LP gas (E)	ft <sup>3</sup> /h	49.0	46.6	17.29
	m <sup>3</sup> /h	1.39	1.32	0.49
Flow Rate at 77°F Rise / 40°C	(Can)	2.7		
	(USA)	3.3		
	G.P.M.	12.5		
Outlet Water Temp. (Approx.)	°F	149		
	°C	65		

table 2





# PORTLAND MAINE

*Strengthening a Remarkable City, Building a Community for Life* • [www.portlandmaine.gov](http://www.portlandmaine.gov)

## Receipts Details:

**Tender Information:** Check , BusinessName: Estate of Madeline page, Check Number: 272  
**Tender Amount:** 80.00

## Receipt Header:

**Cashier Id:** gguertin  
**Receipt Date:** 5/1/2012  
**Receipt Number:** 43418

## Receipt Details:

Referance ID:	6331	Fee Type:	BP-Constr
Receipt Number:	0	Payment Date:	
Transaction Amount:	80.00	Charge Amount:	80.00
Job ID: Job ID: 2012-05-3889-HVAC - install Baxi Luna wall hung (after the fact)			
Additional Comments: 72 wordsworth			

Thank You for your Payment!