

City of Portland, Maine – Building or Use Permit Application 389 Congress Street, 04101, Tel: (207) 874-8703, FAX: 874-8716

Location of Construction: 129 Providence St		Owner: Mazziotti, Randy		Phone: 772-8257		Permit No: 951024	
Owner Address: SAA Ptd, ME 04103		Leasee/Buyer's Name:		Phone:		BusinessName:	
Contractor Name:		Address:		Phone:		<div style="border: 2px solid black; padding: 5px; text-align: center;"> PERMIT ISSUED SEP 27 1995 CITY OF PORTLAND </div>	
Past Use: 2-fam		Proposed Use: Same w/shed		COST OF WORK: \$ 400.00 FIRE DEPT. <input type="checkbox"/> Approved <input type="checkbox"/> Denied Signature:		PERMIT FEE: \$ 25.00 INSPECTION: Use Group: 4 Type: 513 Signature:	
Proposed Project Description: Construct shed (10 x 8)		PEDESTRIAN ACTIVITIES DISTRICT (P.A.D.)		Action: Approved <input type="checkbox"/> Approved with Conditions: <input type="checkbox"/> Denied: <input type="checkbox"/> Signature: _____ Date: _____		Zone: _____ CBL: 425-6-037 Zoning Approval: _____ Special Zone Reviews: <input type="checkbox"/> Shoreland <input type="checkbox"/> Wetland <input type="checkbox"/> Flood Zone <input type="checkbox"/> Subdivision <input type="checkbox"/> Site Plan maj <input type="checkbox"/> minor <input type="checkbox"/> mm <input type="checkbox"/>	
Permit Taken By: Mary Gresik		Date Applied For: 25 September 1995				Zoning Appeal <input type="checkbox"/> Variance <input type="checkbox"/> Miscellaneous <input type="checkbox"/> Conditional Use <input type="checkbox"/> Interpretation <input type="checkbox"/> Approved <input type="checkbox"/> Denied	

1. This permit application doesn't preclude the Applicant(s) from meeting applicable State and Federal rules.
2. Building permits do not include plumbing, septic or electrical work.
3. Building permits are void if work is not started within six (6) months of the date of issuance. False information may invalidate a building permit and stop all work..

CERTIFICATION

I hereby certify that I am the owner of record of the named property, or that the proposed work is authorized by the owner of record and that I have been authorized by the owner to make this application as his authorized agent and I agree to conform to all applicable laws of this jurisdiction. In addition, if a permit for work described in the application issued, I certify that the code official's authorized representative shall have the authority to enter all areas covered by such permit at any reasonable hour to enforce the provisions of the code(s) applicable to such permit

 SIGNATURE OF APPLICANT: Randy Mazziotti ADDRESS: _____ DATE: 25 September 1995 PHONE: _____

RESPONSIBLE PERSON IN CHARGE OF WORK, TITLE _____ PHONE: _____

White-Permit Desk Green-Assessor's Canary-D.P.W. Pink-Public File Ivory Card-Inspector

CEO DISTRICT

6.
H. L. ...

COMMENTS

3/21/96 A Review
Completed

Inspection Record

Type	Date
Foundation: _____	_____
Framing: _____	_____
Plumbing: _____	_____
Final: _____	_____
Other: _____	_____

CABINET STYLE	CABINET HARDWARE	MISC.	APPLIANCES	SPECIAL INSTRUCTIONS

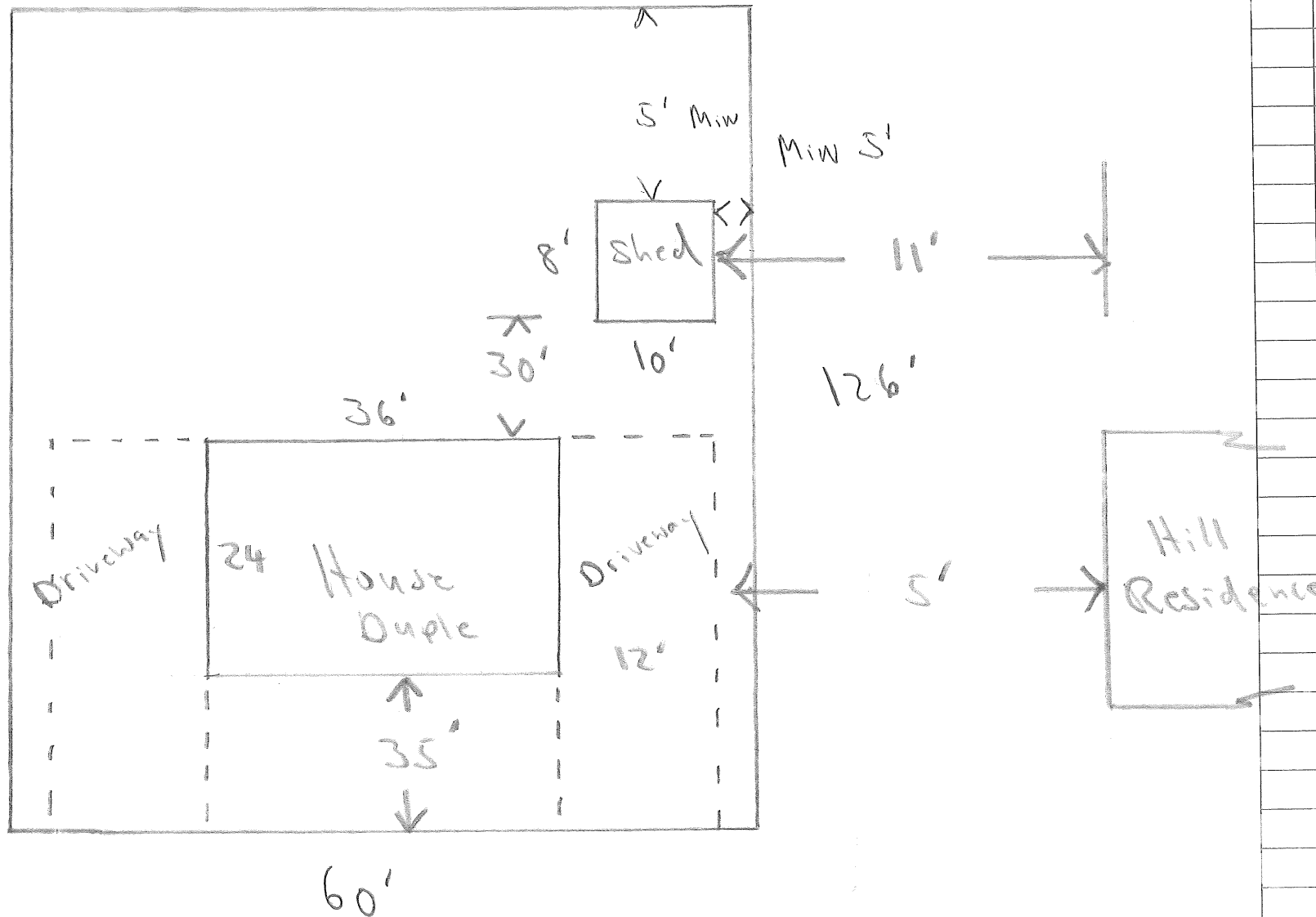

QTY.	CABINET	PRICE

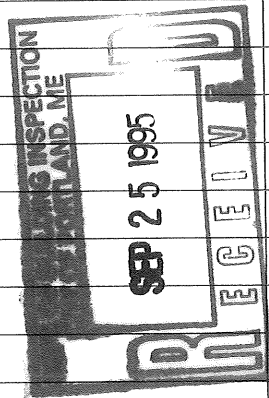

Sold To _____ Delivered To _____ Customer Approval _____
 Address _____ Sold By _____
 _____ Delivery Date _____

List		
Other		
Net		
Sales Tax		
Total		

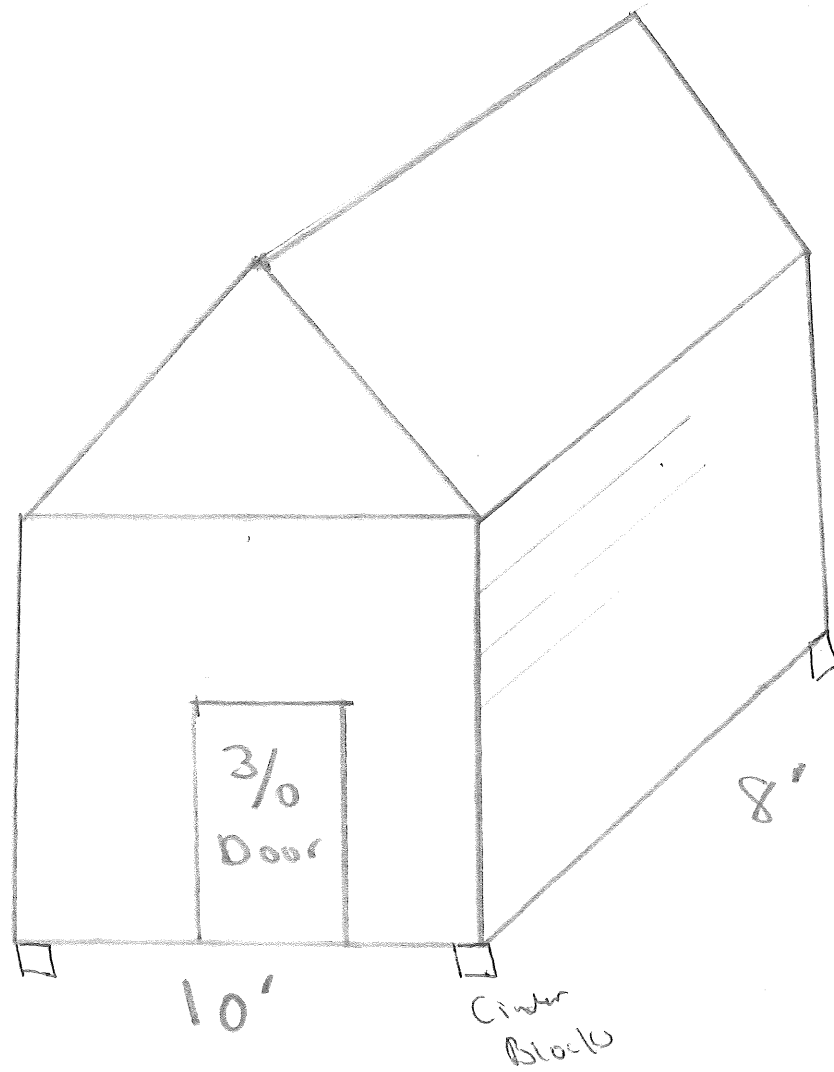

No windows

400.00

6/12 Pitch

2x4 Rafter Rough

2x4 walls

24" O.C.

1/2 Sheathing

Vinyl Siding

2x6 Floor Rough

16" O.C.

Randy Ma

129 Provi

Portland

772-8257

