

City of Portland, Maine - Building or Use Permit Application

389 Congress Street, 04101 Tel: (207) 874-8703, Fax: (207) 874-8716

Permit No: 09-0131	Issue Date:	CBL: 425 A002001
-----------------------	-------------	---------------------

Location of Construction: 125 PRESUMPSCOT ST	Owner Name: PRESUMPSCOT STREET PROPE	Owner Address: PO BOX 403	Phone:
Business Name:	Contractor Name: Coast Line Air	Contractor Address: PO Box 125 Westbrook	Phone: 2072320113
Lessee/Buyer's Name	Phone:	Permit Type: HVAC	Zone: IM

Past Use: Commercial	Proposed Use: Commercial - install a York/Coleman 90+Split system Hot air in attic - w/ 1000 gallon tank	Permit Fee: \$355.00	Cost of Work: \$30,000.00	CEO District: 4
Proposed Project Description: install a York/Coleman 90+Split system Hot air in attic - w/ 1000 gallon tank		FIRE DEPT: <input checked="" type="checkbox"/> Approved <input type="checkbox"/> Denied * See Conditions	INSPECTION: Use Group: B Type: HVAC IMC-2003	

Signature: <i>RC</i>	Signature: <i>AMB 3/5/09</i>
PEDESTRIAN ACTIVITIES DISTRICT (P.A.D.)	
Action: <input type="checkbox"/> Approved <input type="checkbox"/> Approved w/Conditions <input type="checkbox"/> Denied	
Signature:	Date:

Permit Taken By: Ldobson	Date Applied For: 02/18/2009	Zoning Approval	
-----------------------------	---------------------------------	------------------------	--

<ol style="list-style-type: none"> This permit application does not preclude the Applicant(s) from meeting applicable State and Federal Rules. Building permits do not include plumbing, septic or electrical work. Building permits are void if work is not started within six (6) months of the date of issuance. False information may invalidate a building permit and stop all work.. 	Special Zone or Reviews <input type="checkbox"/> Shoreland <input type="checkbox"/> Wetland + Zoning Use made with this Application <input type="checkbox"/> Flood Zone <input type="checkbox"/> Subdivision <input type="checkbox"/> Site Plan Maj <input type="checkbox"/> Minor <input type="checkbox"/> MM <input type="checkbox"/>	Zoning Appeal <input type="checkbox"/> Variance <input type="checkbox"/> Miscellaneous <input type="checkbox"/> Conditional Use <input type="checkbox"/> Interpretation <input type="checkbox"/> Approved <input type="checkbox"/> Denied	Historic Preservation <input checked="" type="checkbox"/> Not in District or Landmark <input type="checkbox"/> Does Not Require Review <input type="checkbox"/> Requires Review <input type="checkbox"/> Approved <input type="checkbox"/> Approved w/Conditions <input type="checkbox"/> Denied
	Date: <i>2/19/09</i>	Date:	Date:

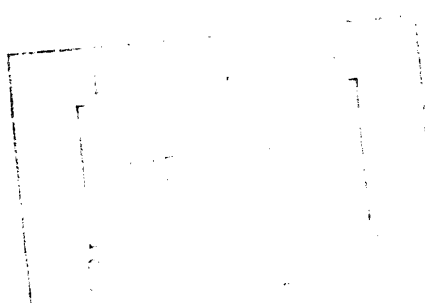

CERTIFICATE OF
SCANNED

I hereby certify that I am the owner of record of the named property, or that the proposed work is authorized by the owner of record and that I have been authorized by the owner to make this application as his authorized agent and I agree to conform to all applicable laws of this jurisdiction. In addition, if a permit for work described in the application is issued, I certify that the code official's authorized representative shall have the authority to enter all areas covered by such permit at any reasonable hour to enforce the provision of the code(s) applicable to such permit.

SIGNATURE OF APPLICANT	ADDRESS	DATE	PHONE
RESPONSIBLE PERSON IN CHARGE OF WORK, TITLE		DATE	PHONE



FILL IN AND SIGN WITH INK

APPLICATION FOR PERMIT HEATING OR POWER EQUIPMENT

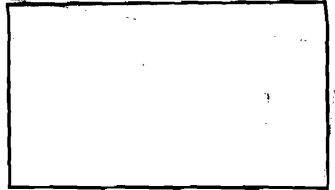

To the INSPECTOR OF BUILDINGS, PORTLAND, ME.

LE. EARL REGAN 3201-34-11

The undersigned hereby applies for a permit to install the following heating, cooking or power equipment in accordance with the Laws of Maine, the Building Code of the City of Portland, and the following specifications:

Location / CBL 125 Presumscott Street Use of Building office Date 2-12-09

Name and address of owner of appliance Jerry ADE Spanwink, medical office

Installer's name and address Coast Line Air mech. Thomas J. Smart
PO BOX 125 Westbrook, ME 04092 Telephone 207-232-0113

Location of appliance:

- Basement
 - Attic
 - Floor
 - Roof
- Above Ceiling
- Platform

Type of Fuel:

- Gas
- Oil
- Solid

Appliance Name: PROPRANE York / Coleman 90+
U.L. Approved Yes No SPLIT SYSTEM HOT AIR

Will appliance be installed in accordance with the manufacture's installation instructions? Yes No

IF NO Explain: _____

The Type of License of Installer:

- Master Plumber # _____
- Solid Fuel # _____
- Oil # _____
- Gas # PNT # 2671 ME GAS
- Other hic

Type of Chimney:

- Masonry Lined
- Factory built _____

- Metal
- Factory Built U.L. Listing # _____

Direct Vent
Type Sch 40 PVC UL# _____

Type of Fuel Tank

- Oil
- Gas PROPANE - ERNSTING

Size of Tank 1000 underground

Number of Tanks (1)

Distance from Tank to Center of Flame 50 ^{ft} feet.

Cost of Work: \$ 30,000.00 320

Permit Fee: \$ 450.00 + 35 tank
355

Approved

Approved with Conditions

Fire: _____
Ele.: _____
Bldg.: _____

- See attached letter or requirement

Signature of Installer Thomas J. Smart Toms.

Inspector's Signature

Date Approved

SUBMITTAL DATA SHEET

**ADD - ON COILS FOR USE WITH SPLIT-SYSTEM
COOLING & HEAT PUMPS**
MODELS: MC, FC

JOB NAME: _____			LOCATION: _____		
PURCHASER: _____			ORDER NO: _____		
ENGINEER: _____					
SUBMITTED TO: _____		FOR: _____	REF: _____	APPROVAL: _____	CONSTRUCTION: _____
SUBMITTED BY: _____			DATE: _____		
UNIT DESIGNATION: _____			SCHEDULE NO. _____	MODEL NO. _____	

PRODUCT DATA

Cooling Performance

Total Capacity* _____ MBH
Sensible Capacity* _____ MBH
Temperature of Air Entering
Indoor Coil _____ °F (DB/WB)

Supply Air Blower Performance

Total Supply Air _____ CFM
Total Resistance External To Unit _____ IWG
Blower Speed Tap _____ RPM
Motor Rating _____ HP

Electrical Data

Power Supply _____ / _____ / _____
Total Unit Ampacity _____ AMPS
Minimum Wire Size _____ AWG
(Copper conductors)
Maximum Overcurrent Device _____ AMPS
 Fuses (Dual Element)
 Circuit Breaker (HACR)

Unit Weight

Total Operating Weight _____ LBS
(Including field-installed accessories)
* Shown in Outdoor Unit Technical Guide

CLEARANCES

Front	24"
Rear	0"
Sides	0"

Recommended service clearance.



FEATURES

MC & FC COILS

- Rifled copper tubes and aluminum fins
- MicroBlueTM fin coating
- Sweat connect refrigerant connections
- MC - upflow, downflow and horizontal applications
- FC - upflow or downflow applications
- 3/4" insulation standard
- Available with or without factory installed R-22 TXV

MATCHED INDOOR UNIT

- Model Number (# _____)
 Submittal Part Number (# _____)

MATCHED OUTDOOR UNIT

- Model Number (# _____)
 Submittal Part Number (# _____)

FIELD INSTALLED ACCESSORIES

- Electric Heaters (# _____)
 Capacity (@ _____ Volts) _____ MBH
 Power Input Requirement (Less Blower Motor) _____ KW
 Filter Rack (# _____)
 Combustible Floor Base (# _____)
 Interconnecting Lines Length _____ Ft
 Thermal Expansion Valve Kit (# _____)

DIMENSIONS - INCHES

Dimensions - MC Coils

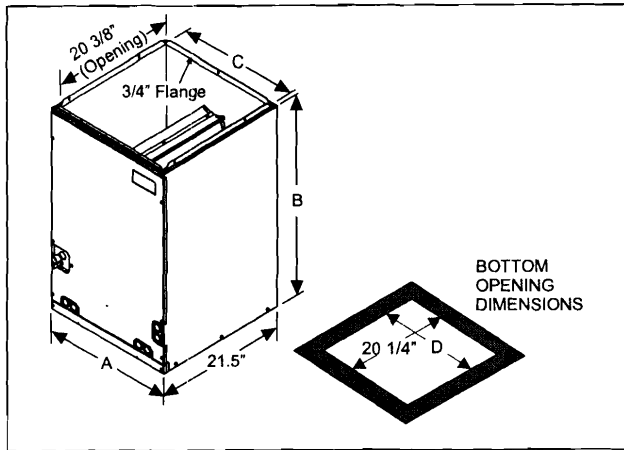

COIL - MC

Dimensions - MC Coils

Model	A	B	C	D	Refrigerant Line Size ¹		Factory Installed TXV
					Liquid	Vapor	
MC18A2AH1	14.5	22	13 3/8	13.5	3/8	3/4	2A
MC18A3XH1	14.5	22	13 3/8	13.5	3/8	3/4	None
MC18A4EH1	14.5	22	13 3/8	13.5	3/8	3/4	4E
MC18B2AH1	17.5	22	16 3/8	16.5	3/8	3/4	2A
MC18B3XH1	17.5	22	16 3/8	16.5	3/8	3/4	None
MC18B4EH1	17.5	22	16 3/8	16.5	3/8	3/4	4E
MC24A2AH1	14.5	26.5	13 3/8	13.5	3/8	3/4	2A
MC24A3XH1	14.5	26.5	13 3/8	13.5	3/8	3/4	None
MC24A4FH1	14.5	26.5	13 3/8	13.5	3/8	3/4	4F
MC24B2AH1	17.5	26.5	16 3/8	16.5	3/8	3/4	2A
MC24B3XH1	17.5	26.5	16 3/8	16.5	3/8	3/4	None
MC24B4FH1	17.5	26.5	16 3/8	16.5	3/8	3/4	4F
MC30A2AH1	14.5	26.5	13 3/8	13.5	3/8	3/4	2A
MC30A3XH1	14.5	26.5	13 3/8	13.5	3/8	3/4	None
MC30A4EH1	14.5	26.5	13 3/8	13.5	3/8	3/4	4E
MC30A4FH1	14.5	26.5	13 3/8	13.5	3/8	3/4	4F
MC30B2AH1	17.5	26.5	16 3/8	16.5	3/8	3/4	2A
MC30B3XH1	17.5	26.5	16 3/8	16.5	3/8	3/4	None
MC30B4EH1	17.5	26.5	16 3/8	16.5	3/8	3/4	4E
MC30B4FH1	17.5	26.5	16 3/8	16.5	3/8	3/4	4F
MC32A2AH1	14.5	22	13 3/8	13.5	3/8	3/4	2A
MC32A3XH1	14.5	22	13 3/8	13.5	3/8	3/4	None
MC32A4FH1	14.5	22	13 3/8	13.5	3/8	3/4	4F
MC32A4GH1	14.5	22	13 3/8	13.5	3/8	3/4	4G
MC32A4MH1	14.5	22	13 3/8	13.5	3/8	3/4	4M
MC35B2AH1	17.5	22	16 3/8	16.5	3/8	3/4	2A
MC35B3XH1	17.5	22	16 3/8	16.5	3/8	3/4	None
MC35B4FH1	17.5	22	16 3/8	16.5	3/8	3/4	4F
MC35B4GH1	17.5	22	16 3/8	16.5	3/8	3/4	4G
MC35B4HH1	17.5	22	16 3/8	16.5	3/8	3/4	4H
MC35B4MH1	17.5	22	16 3/8	16.5	3/8	3/4	4M
MC35C2AH1	21	22	19 7/8	20	3/8	3/4	2A
MC35C3XH(1,2)	21	26.5/22	19 7/8	20	3/8	3/4	None
MC35C4FH1	21	22	19 7/8	20	3/8	3/4	4F
MC35C4GH1	21	22	19 7/8	20	3/8	3/4	4G
MC35C4HH1	21	22	19 7/8	20	3/8	3/4	4H
MC35C4MH1	21	22	19 7/8	20	3/8	3/4	4M
MC36A2AH1	14.5	26.5	13 3/8	13.5	3/8	7/8	2A
MC36A3XH1	14.5	26.5	13 3/8	13.5	3/8	7/8	None
MC36A4EH1	14.5	26.5	13 3/8	13.5	3/8	7/8	4E
MC36A4FH1	14.5	26.5	13 3/8	13.5	3/8	7/8	4F
MC36A4GH1	14.5	26.5	13 3/8	13.5	3/8	7/8	4G

Model	A	B	C	D	Refrigerant Line Size ¹		Factory Installed TXV
					Liquid	Vapor	
MC36A4HH1	14.5	26.5	13 3/8	13.5	3/8	7/8	4H
MC36B2AH1	17.5	26.5	16 3/8	16.5	3/8	7/8	2A
MC36B3XH1	17.5	26.5	16 3/8	16.5	3/8	7/8	None
MC36B4EH1	17.5	26.5	16 3/8	16.5	3/8	7/8	4E
MC36B4FH1	17.5	26.5	16 3/8	16.5	3/8	7/8	4F
MC36B4GH1	17.5	26.5	16 3/8	16.5	3/8	7/8	4G
MC36B4HH1	17.5	26.5	16 3/8	16.5	3/8	7/8	4H
MC36C2AH1	21	26.5	19 7/8	20	3/8	7/8	2A
MC36C3XH1	21	26.5	19 7/8	20	3/8	7/8	None
MC3C4EH1	21	26.5	19 7/8	20	3/8	7/8	4E
MC3C4GH1	21	26.5	19 7/8	20	3/8	7/8	4G
MC36C4HH1	21	26.5	19 7/8	20	3/8	7/8	4H
MC37A2AH1	14.5	26.5	13 3/8	13.5	3/8	3/4	2A
MC37A3XH1	14.5	26.5	13 3/8	13.5	3/8	3/4	None
MC37A4EH1	14.5	26.5	13 3/8	13.5	3/8	3/4	4E
MC37A4FH1	14.5	26.5	13 3/8	13.5	3/8	3/4	4F
MC42B2CH1	17.5	32	16 3/8	16.5	3/8	7/8	2C
MC42B3XH1	17.5	32	16 3/8	16.5	3/8	7/8	None
MC42B4FH1	17.5	32	16 3/8	16.5	3/8	7/8	4F
MC42B4HH1	17.5	32	16 3/8	16.5	3/8	7/8	4H
MC42C2CH1	21	32	19 7/8	20	3/8	7/8	2C
MC42C3XH1	21	32	19 7/8	20	3/8	7/8	None
MC42C4FH1	21	32	19 7/8	20	3/8	7/8	4F
MC42C4HH1	21	32	19 7/8	20	3/8	7/8	4H
MC43B2CH1	17.5	26.5	16 3/8	16.5	3/8	7/8	2C
MC43B3XH1	17.5	26.5	16 3/8	16.5	3/8	7/8	None
MC43B4GH1	17.5	26.5	16 3/8	16.5	3/8	7/8	4G
MC43B4KH1	17.5	26.5	16 3/8	16.5	3/8	7/8	4K
MC43B4MH1	17.5	26.5	16 3/8	16.5	3/8	7/8	4M
MC43C2CH1	21	26.5	19 7/8	20	3/8	7/8	2C
MC43C3XH1	21	26.5	19 7/8	20	3/8	7/8	None
MC43C4GH1	21	26.5	19 7/8	20	3/8	7/8	4G
MC43C4KH1	21	26.5	19 7/8	20	3/8	7/8	4K
MC43C4MH1	21	26.5	19 7/8	20	3/8	7/8	4M
MC48C2CH1	21	32	19 7/8	20	3/8	7/8	2C
MC48C3XH1	21	32	19 7/8	20	3/8	7/8	None
MC48C4FH1	21	32	19 7/8	20	3/8	7/8	4F
MC48C4HH1	21	32	19 7/8	20	3/8	7/8	4H
MC48C4JH1	21	32	19 7/8	20	3/8	7/8	4J
MC48C4KH1	21	32	19 7/8	20	3/8	7/8	4K
MC48D2CH1	24.5	32	23 3/8	23.5	3/8	7/8	2C
MC48D3XH1	24.5	32	23 3/8	23.5	3/8	7/8	None
MC48D4FH1	24.5	32	23 3/8	23.5	3/8	7/8	4F
MC48D4HH1	24.5	32	23 3/8	23.5	3/8	7/8	4H
MC48D4JH1	24.5	32	23 3/8	23.5	3/8	7/8	4J
MC48D4KH1	24.5	32	23 3/8	23.5	3/8	7/8	4K
MC60D2CH1	24.5	32	23 3/8	23.5	3/8	7/8	2C
MC60D3XH1	24.5	32	23 3/8	23.5	3/8	7/8	None
MC60D4GH1	24.5	32	23 3/8	23.5	3/8	7/8	4G
MC60D4HH1	24.5	32	23 3/8	23.5	3/8	7/8	4H
MC60D4JH1	24.5	32	23 3/8	23.5	3/8	7/8	4J
MC60D4KH1	24.5	32	23 3/8	23.5	3/8	7/8	4K
MC62D2CH1	24.5	36	23 3/8	23.5	3/8	7/8	2C
MC62D3XH1	24.5	36	23 3/8	23.5	3/8	7/8	None
MC62D4HH1	24.5	36	23 3/8	23.5	3/8	7/8	4H
MC62D4JH1	24.5	36	23 3/8	23.5	3/8	7/8	4J
MC62D4KH1	24.5	36	23 3/8	23.5	3/8	7/8	4K

All MC coils include a factory installed horizontal drain pan.

(3X) = Models require field installed metering device.

1. Refrigerant line sizes may require larger lines for extended line lengths. See York bulletin #690.01-AD1V for details.

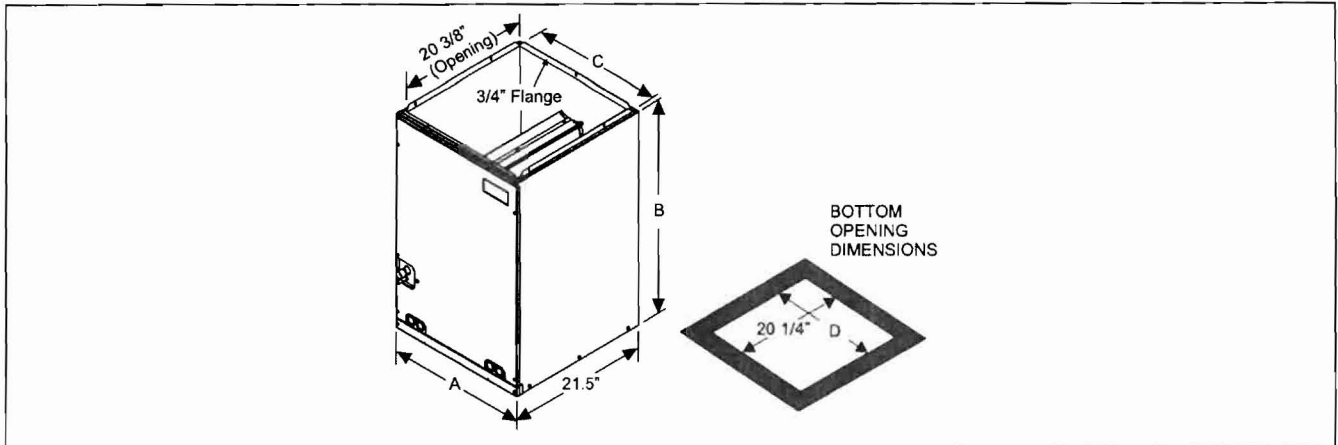

COIL - FC

Dimensions - FC Coils

Model	A	B	C	D	Refrigerant Line Size ¹		Factory Installed TXV
					Liquid	Vapor	
FC18A2AN1	14.5	18	13 3/8	13.5	3/8	3/4	2A
FC18A3XN1	14.5	18	13 3/8	13.5	3/8	3/4	None
FC18B2AN1	17.5	18	16 3/8	16.5	3/8	3/4	2A
FC18B3XN1	17.5	18	16 3/8	16.5	3/8	3/4	None
FC24A2AN1	14.5	22	13 3/8	13.5	3/8	3/4	2A
FC24A3XN1	14.5	22	13 3/8	13.5	3/8	3/4	None
FC24B2AN1	17.5	22	16 3/8	16.5	3/8	3/4	2A
FC24B3XN1	17.5	22	16 3/8	16.5	3/8	3/4	None
FC30A2AN1	14.5	22	13 3/8	13.5	3/8	3/4	2A
FC30A3XN1	14.5	22	13 3/8	13.5	3/8	3/4	None
FC30B2AN1	17.5	22	16 3/8	16.5	3/8	3/4	2A
FC30B3XN1	17.5	22	16 3/8	16.5	3/8	3/4	None
FC32A2AN1	14.5	20	13 3/8	13.5	3/8	3/4	2A
FC32A3XN1	14.5	20	13 3/8	13.5	3/8	3/4	None
FC35B2AN1	17.5	20	16 3/8	16.5	3/8	3/4	2A
FC35B3XN2	17.5	20	16 3/8	16.5	3/8	3/4	None
FC35C2AN1	21	20	19 7/8	20	3/8	3/4	2A
FC35C3XN(1,2)	21	24.5/20	19 7/8	20	3/8	3/4	None
FC36A2AN1	14.5	24.5	13 3/8	13.5	3/8	7/8	2A
FC36A3XN1	14.5	24.5	13 3/8	13.5	3/8	7/8	None
FC36B2AN1	17.5	24.5	16 3/8	16.5	3/8	7/8	2A
FC36B3XN1	17.5	24.5	16 3/8	16.5	3/8	7/8	None
FC36C2AN1	21	24.5	19 7/8	20	3/8	7/8	2A
FC36C3XN1	21	24.5	19 7/8	20	3/8	7/8	None

Dimensions - FC Coils

Model	A	B	C	D	Refrigerant Line Size ¹		Factory Installed TXV
					Liquid	Vapor	
FC37A2AN1	14.5	24.5	13 3/8	13.5	3/8	3/4	2A
FC37A3XN1	14.5	24.5	13 3/8	13.5	3/8	3/4	None
FC42B2CN1	17.5	28	16 3/8	16.5	3/8	7/8	2C
FC42B3XN1	17.5	28	16 3/8	16.5	3/8	7/8	None
FC42C2CN1	21	28	19 7/8	20	3/8	7/8	2C
FC42C3XN1	21	28	19 7/8	20	3/8	7/8	None
FC43B2CN1	17.5	24.5	16 3/8	16.5	3/8	7/8	2C
FC43B3XN1	17.5	24.5	16 3/8	16.5	3/8	7/8	None
FC43C2CN1	21	24.5	19 7/8	20	3/8	7/8	2C
FC43C3XN1	21	24.5	19 7/8	20	3/8	7/8	None
FC48C2CN1	21	28	19 7/8	20	3/8	7/8	2C
FC48C3XN1	21	28	19 7/8	20	3/8	7/8	None
FC48D2CN1	24.5	28	23 3/8	23.5	3/8	7/8	2C
FC48D3XN1	24.5	28	23 3/8	23.5	3/8	7/8	None
FC60C2CN1	21	28	19 7/8	20	3/8	7/8	2C
FC60C3XN1	21	28	19 7/8	20	3/8	7/8	None
FC60D2CN1	24.5	28	23 3/8	23.5	3/8	7/8	2C
FC60D3XN1	24.5	28	23 3/8	23.5	3/8	7/8	None
FC62D2CN1	24.5	32	23 3/8	23.5	3/8	7/8	2C
FC62D3XN1	24.5	32	23 3/8	23.5	3/8	7/8	None

All FC coils are not available with a factory installed horizontal drain pan.
 (3X) = Models require field installed metering device.

1. Refrigerant line sizes may require larger lines for extended line lengths. See York bulletin #690.01-AD1V for details.

MODULAR AIR HANDLER TYPICAL APPLICATIONS*

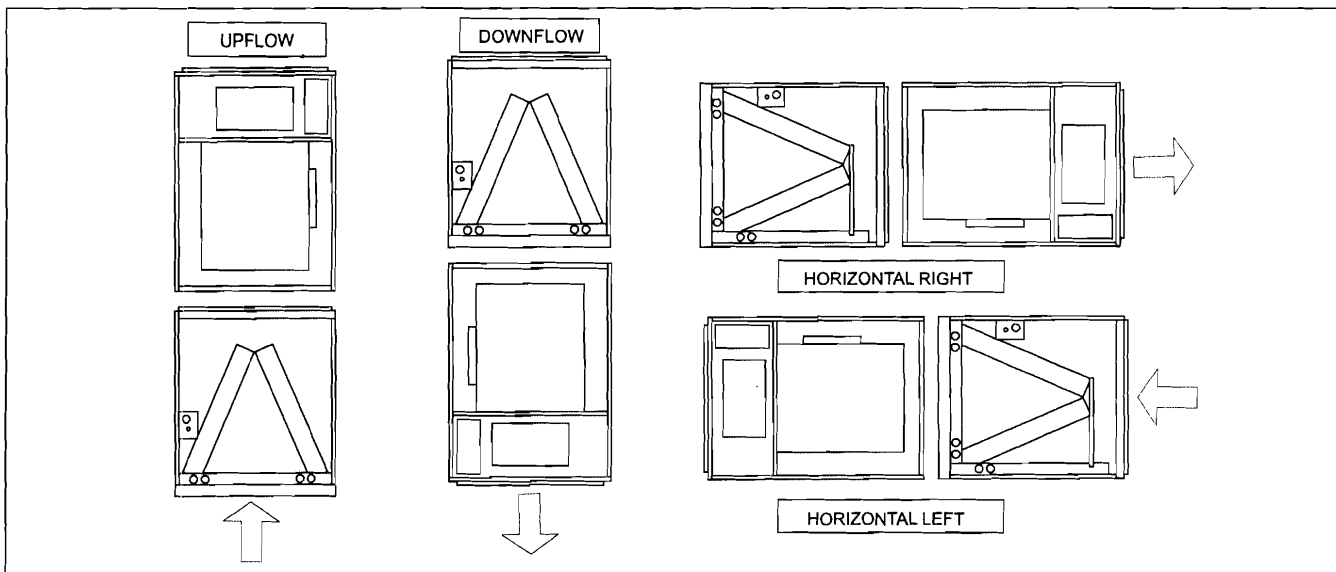

* See installation manual for furnace applications.

SUBMITTAL DATA SHEET

95.5% SINGLE STAGE GAS-FIRED RESIDENTIAL MULTI-POSITION GAS FURNACES MODELS: GG9S

JOB NAME:		LOCATION:	
PURCHASER:		ORDER NO.:	
ENGINEER:			
SUBMITTED TO:	FOR:	REF:	APPROVAL:
SUBMITTED BY:		DATE:	
UNIT DESIGNATION:	SCHEDULE NO.:	MODEL NO.:	

DIMENSIONS - INCHES

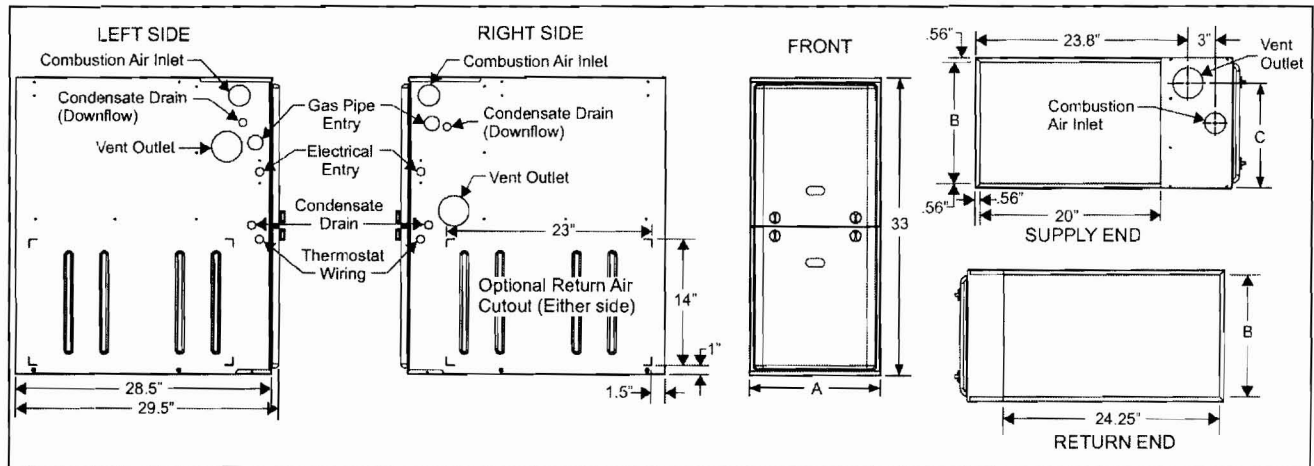

BTUH (kW) Input	Nominal CFM	Cabinet Size	Cabinet Dimensions (Inches)			Approximate Operating Weights Lbs
			A	B	C	
GG9S040A08MP11	800	A	14 1/2	13 3/8	11 3/4	113
GG9S060A10MP11	1000	A	14 1/2	13 3/8	11 3/4	118
GG9S060B12MP11	1200	B	17 1/2	16 3/8	13 1/4	122
GG9S080B12MP11	1200	B	17 1/2	16 3/8	14 3/4	126
GG9S080C16MP11	1600	C	21	19 7/8	16 1/2	136
GG9S080C22MP11	2200	C	21	19 7/8	16 1/2	139
GG9S100C16MP11	1600	C	21	19 7/8	18 1/4	142
GG9S100C20MP11	2000	C	21	19 7/8	18 1/4	145
GG9S120D16MP11	1600	D	24 1/2	23 3/8	21 3/4	153
GG9S120D20MP11	2000	D	24 1/2	23 3/8	21 3/4	156
GG9S130D20MP11	2000	D	24 1/2	23 3/8	No Hole	160

Due to continuous product improvements, specifications are subject to change without notice. Installation and conversions of these furnaces must be made by qualified distributor, dealer, or contractor personnel.



PRODUCT DATA

Heating Performance

Input Capacity _____ MBH
Output Capacity _____ MBH
Air Temp. Rise _____ °F

Supply Air Blower Performance

Total Supply Air _____ CFM
Total External Static Pressure _____ IWG
Blower Speed (circle) ___ HI MH ML L
Motor Rating _____ HP

Electrical Data

Power Supply _____ / /

Total Unit Ampacity _____ AMPS
Minimum Wire Size _____ AWG
Maximum Overcurrent Device

Fuses Circuit Breaker _____ AMPS

Unit Weight

Total Unit Weight _____ LBS

FEATURES

- Easily applied in upflow, horizontal left or right, or downflow installation with minimal conversion necessary.
- Compact, easy to install, ideal height 33" tall cabinet.
- Blower-off delay for cooling SEER improvement.
- Easy access to controls to connect power/control wiring.
- Built-in, high level self diagnostics with fault code displays standard on integrated control module for reliable operation.
- Low unit amp requirement for easy replacement application.
- Single wire twinning or staging feature available.
- All models are convertible to use propane (LP) gas.
- Electronic Hot Surface Ignition saves fuel cost with increased dependability and reliability.
- 100% shut off main gas valve for extra safety.
- 4 speed, direct drive PSC motor.
- 24V, 40 VA control transformer and blower relay supplied for add-on cooling.
- Hi-tech tubular aluminized steel primary heat exchanger.
- Secondary heat exchanger made of corrosion resistant stainless steel materials.
- Timed on, adjustable off blower capability for maximum comfort.
- Blower door safety switch.
- Solid removable bottom panel allows easy conversion.
- Airflow leakage less than 1% of Nominal airflow at ductblaster conditions.
- No knockouts to deal with, making installation easier.
- Movable duct connector flanges for application flexibility.
- Quiet inducer operation.
- Inducer rotates for easy conversion of venting options.
- Fully supported blower assembly for easy access and removal of blower.
- External air filters used for maximum flexibility in meeting customers IAQ needs.
- Protection included from air intake, exhaust vent, or condensate blockage.
- Patent pending self priming internal condensate trap design for easy installation.
- Venting applications - may be installed as either 2-pipe (sealed combustion) or single-pipe vent (using indoor combustion air).
- No special vent termination required.
- 1/4 turn knobs provided for easy door removal.

FIELD INSTALLED ACCESSORIES

PROPANE (LP) CONVERSION KIT -

S1-1NP0347 - All Models except 130K Model
S1-1NP0501 - 130K Model

This accessory conversion kit may be used to convert natural gas (N) units for propane (LP) operation.

CONCENTRIC VENT TERMINATION -

S1-1CT0302 (2")
S1-1CT0303 (3")

For use through rooftop, sidewall. Allows combustion air to enter and exhaust to exit through single common hole. Eliminates unsightly elbows for a cleaner installation.

SIDEWALL VENT TERMINATION KIT -

S1-1HT0901 (3")
S1-1HT0902 (2")

For use on sidewall, two-pipe installations only. Provide a more attractive termination for locations where the terminal is visible on the side of the home.

CONDENSATE NEUTRALIZER KIT - 1NK0301

Neutralizer cartridge has a 1/2" plastic tube fittings for installation in the drain line. Calcium carbonate refill media is also available from the Source 1 Parts (p/n 026-30228-000).

SIDE RETURN FILTER RACKS -

S1-1SR0200 - All Models
S1-1SR0402 - All Models
S1-1SF0101 - All Models (Upflow Only)

BOTTOM RETURN FILTER RACKS -

S1-1BR0514 or 1BR0614 - For 14-1/2" cabinets
S1-1BR0517 or 1BR0617 - For 17-1/2" cabinets
S1-1BR0521 or 1BR0621 - For 21" cabinets
S1-1BR0524 or 1BR0624 - For 24-1/2" cabinets

1BR05xx series are galvanized steel filter racks. 1BR06xx are pre-painted steel filter racks to match the appearance of the furnace cabinet.

COMBUSTIBLE FLOOR BASE KIT -

For installation of these furnaces in downflow applications directly onto combustible flooring material, These kits are required to prevent potential overheating situations.

S1-1CB0514 - For 14-1/2" cabinets
S1-1CB0517 - For 17-1/2" cabinets
S1-1CB0521 - For 21" cabinets
S1-1CB0524 - For 24-1/2" cabinets

EAC TRANSITION KITS -

For installation of EAC accessories with these furnaces to provide easy transition of return airflow through the EAC to get the proper sealing and reduced airflow leakage.

S1-1TK1001 - For all models using side return
S1-1TK1014 - For 14-1/2" cabinets using bottom return
S1-1TK1017 - For 17-1/2" cabinets using bottom return
S1-1TK1021 - For 21" cabinets using bottom return
S1-1TK1024 - For 24-1/2" cabinets using bottom return

HIGH ALTITUDE PRESSURE SWITCHES -

For installation where the altitude is less than 5,000 feet it is not required that the pressure switch be changed. For altitudes above 5,000 feet, see kits below.

S1-1PS3306 - 040, 080
S1-1PS3307 - 060
S1-1PS3302 - 100, 120, 130

SUBMITTAL DATA SHEET

**R-410A SPLIT SYSTEM AIR CONDITIONERS
2 THRU 5 TONS
MODELS: 14.5 SEER TCGF24 THRU 60**

JOB NAME:		LOCATION:		
PURCHASER:		ORDER NO:		
ENGINEER:				
SUBMITTED TO:	FOR:	REF:	APPROVAL:	CONSTRUCTION:
SUBMITTED BY:		DATE:		
UNIT DESIGNATION:		SCHEDULE NO.	MODEL NO.	

PRODUCT DATA

Cooling Performance

Total Capacity _____ MBH
Outdoor Design Temp _____ °F

Electrical Data

Power Supply _____ / _____ / _____
Compressor Ampacity _____ AMPs
Total Unit Ampacity _____ AMPs
Power Input Req _____ KW
Minimum Wire Size _____ AWG
Overcurrent Device
 Fuses Circuit Breaker

Unit Weight

Unit Weight _____ LBS

DIMENSIONS - INCHES

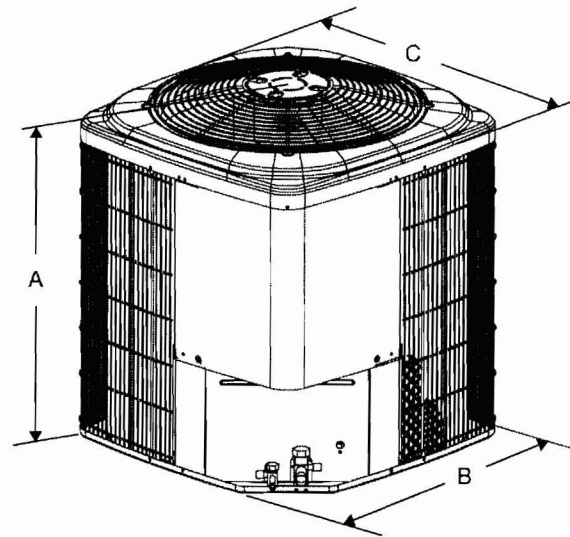

All dimensions are in inches. They are subject to change without notice. Certified dimensions will be provided upon request.



ARI Standard 216/243
Unitary Heat Pumps



Unit Model	Dimensions (Inches)			Refrigerant Connection Service Valve Size	
	A ¹	B	C	Liquid	Vapor
24	28	29	29	3/8"	3/4"
30	36	29	29		
36	36	29	29		7/8"
42	34	33.6	33.6		
48	36	33.6	33.6		
60	40	33.6	33.6	7/8" ²	

1. Including Fan Guard.
2. Adapter fitting required for 1-1/8" line set.

FEATURES

- UL approval (units & accessories).
- CUL listed.
- Certified in accordance with the Unitary Small Equipment certification program, which the ARI Standard 210/240.
- 5-year limited parts warranty.
- 10-year limited warranty on the compressor.
- All aluminum coil
- Internally protected compressor.
- High Pressure Switch
- Propeller type fan.
- Durable construction.
- Pre-painted steel cabinet.
- Factory wired.
- Sweat refrigerant connections.
- Re-useable brass service valves.
- Easy access to electrical compartment.
- Liquid line filter dryer.
- Powder coated fan guard and coil guard.
- 18 gauge G90 galvanized formed base pan.

CLEARANCES

Service Access	24 Inches
All Other Sides	10 Inches
Above Unit	48 Inches
Below Unit	0 Inches

MATCHING AIR SIDE EQUIPMENT

Model No. _____

Submittal Form No. _____

FIELD INSTALLED ACCESSORIES

Off Cycle Timer (2TD08700124) _____

Thermostats _____

Blower Off Delay (2FD06700224) _____

Low Ambient Pressure Switch _____

NOTES:

Subject to change without notice. Printed in U.S.A.
Copyright © 2008 by Johnson Controls, Inc. All rights reserved.

413436-USD-B-0708
Supersedes: 413436-USD-A-0608

Johnson Controls Unitary Products
5005 York Drive
Norman, OK 73069

VENT CLEARANCES

FIGURE 28: Home Layout

Direct Vent Terminal Clearances	Canadian Installations ^{1,3}	US Installation ^{2,3}
A. Clearance above grade, veranda, porch, deck, or balcony	12 inches (30 cm)	12 inches (30 cm)
B. Clearance to window or door that may be opened	12 inches (30 cm) for models ≤100,000 BTUH (30 kW), 36 inches (91 cm) for models >100,000 BTUH (30 kW)	Two-pipe (direct vent) applications: 9 inches (23 cm) for models ≤50,000 BTUH (15 kW), 12 inches (30 cm) for models >50,000 BTUH (15 kW). †† Single-pipe applications: 4 feet
C. Clearance to permanently closed window	12 inches (30 cm)	12 inches (30 cm)
D. Vertical clearance to ventilated soffit located above the terminal within a horizontal distance of 2 feet (61 cm) from the center line of the terminal	12 inches (30 cm) or in accordance with local installation codes and the requirements of the gas supplier.	12 inches (30 cm) or in accordance with local installation codes and the requirements of the gas supplier
E. Clearance to unventilated soffit	12 inches (30 cm) or in accordance with local installation codes and the requirements of the gas supplier	12 inches (30 cm) or in accordance with local installation codes and the requirements of the gas supplier
F. Clearance to outside corner	12 inches (30 cm) or in accordance with local installation codes and the requirements of the gas supplier	12 inches (30 cm) or in accordance with local installation codes and the requirements of the gas supplier
G. Clearance to inside corner	3 feet (91 cm)	3 feet (91 cm)
H. Clearance to each side of center line extended above meter/regulator assembly	Above a meter/regulator assembly within 3 feet (91 cm) horizontally of the vertical center-line of the regulator vent outlet to a maximum vertical distance of 15 feet (4.5 cm) above the meter/regulator assembly.	Above a meter/regulator assembly within 3 feet (91 cm) horizontally of the vertical center-line of the regulator vent outlet to a maximum vertical distance of 15 feet (4.5 cm) above the meter/regulator assembly.
I. Clearance to service regulator vent outlet	3 feet (91 cm)	3 feet (91 cm) or in accordance with local installation codes and the requirements of the gas supplier.
J. Clearance to nonmechanical air supply inlet to building or the combustion air inlet to any other appliance	12 inches (30 cm) for models ≤100,000 BTUH (30 kW), 36 inches (91 cm) for models >100,000 BTUH (30 kW)	Two-pipe (direct vent) applications: 9 inches (23 cm) for models ≤50,000 BTUH (15 kW), 12 inches (30 cm) for models >50,000 BTUH (15 kW). Single-pipe applications: 4 feet
K. Clearance to a mechanical supply inlet	6 feet (1.83 m)	3 feet (91 cm) above if within 10 feet (3 cm) horizontally
L. Clearance above paved sidewalk or paved driveway located on public property	7 feet (2.13 m)†	7 feet (2.13 m) or in accordance with local installation codes and the requirements of the gas supplier.
M. Clearance under veranda, porch, deck, or balcony	12 inches (30 cm)‡	12 inches (30 cm) or in accordance with local installation codes and the requirements of the gas supplier.

1. In accordance with the current CSA B149.1-00, Natural Gas and Propane Installation Code.

2. In accordance with the current ANSI Z223.1 / NFPA 54, National Gas Code.

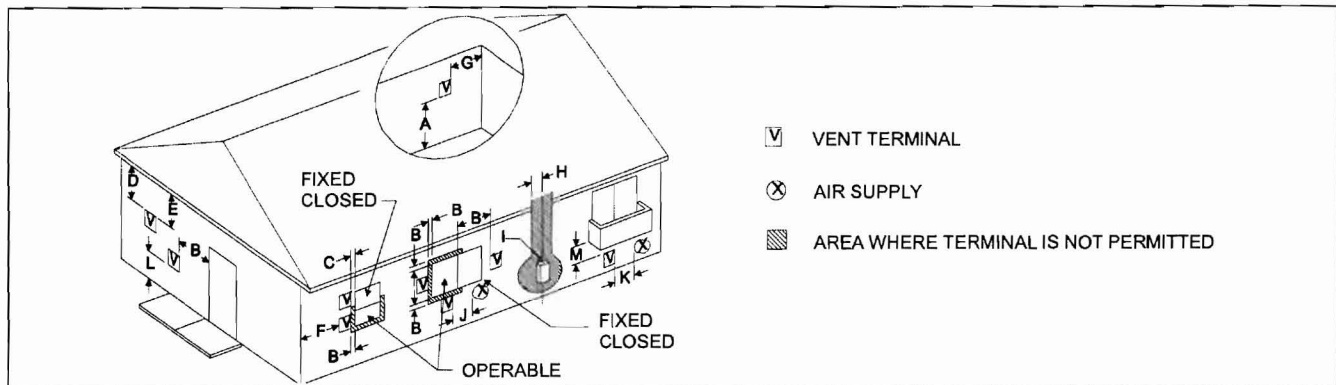
3. In accordance with the current ANSI Z21.47 * CSA 2.3 American National Standard.

† A vent shall not terminate directly above a sidewalk or paved driveway that is located between two single family dwellings and serves both dwellings.

†† 12 inches (30 cm) up from the bottom edge of the structure for Two-pipe (direct vent) applications per ANSI Z223.1 / NFPA 54, National Gas Code.

‡ Permitted only if veranda, porch, deck, or balcony is fully open on a minimum of two sides beneath the floor and the distance between the top of the vent termination and the underside of the veranda, porch, or deck is greater than 1 foot (30 cm) as specified in CSA B149.1-00.

A vent shall not terminate less than 1 foot (30 cm) above a grade level.

Any fresh air or make up inlet for dryer or furnace area is considered to be forced air inlet.

Avoid areas where condensate drippage may cause problems such as above planters, patios, or adjacent to windows where steam may cause fogging.

A terminus of a vent shall be fitted with a cap in accordance with the vent manufacturer's installation instructions, or in accordance with the installation instructions for a special venting system.

Responsibility for the provision of proper adequate venting and air supply for application shall rest with the installer.

Vent shall extend high enough above building, or a neighboring obstruction, so that wind from any direction will not create a positive pressure in the vicinity of the vent.

IMPORTANT

Consideration must be given for degradation of building materials by flue gases. Sidewall termination may require sealing or shielding of building surfaces with a corrosion resistant material to protect against combustion product corrosion. Consideration must be given to wind direction in order to prevent flue products and/or condensate from being blown against the building surfaces. If a metal shield is used it must be a stainless steel material at a minimum dimension of 20 inches. It is recommended that a retaining type collar be used that is attached to the building surface to prevent movement of the vent pipe.

VENT SYSTEM

This furnace is certified to be installed with one of two possible vent configurations.

1. Horizontal vent system. This vent system can be installed completely horizontal or combinations of horizontal, vertical, or offset using elbows.
2. Vertical vent system. This vent system can be installed completely vertical or a combination of horizontal, vertical, or offset using elbows.

VENT APPLICATIONS AND TERMINATION

When selecting the location for a combustion air / vent termination, the following should be considered:

1. Observe all clearances listed in vent clearances in these instructions.
2. Termination should be positioned where vent vapors will not damage plants or shrubs or air conditioning equipment.
3. Termination should be located where it will not be affected by wind gusts, light snow, airborne leaves or allow recirculation of flue gases.
4. Termination should be located where it will not be damaged or exposed to flying stones, balls, etc.
5. Termination should be positioned where vent vapors are not objectionable.
6. Horizontal portions of the vent system must slope upwards and be supported to prevent sagging.
7. Direct vent systems must be installed so the vent and the combustion air pipes terminate in the same atmospheric zone. Refer to Figures 13 or 14.

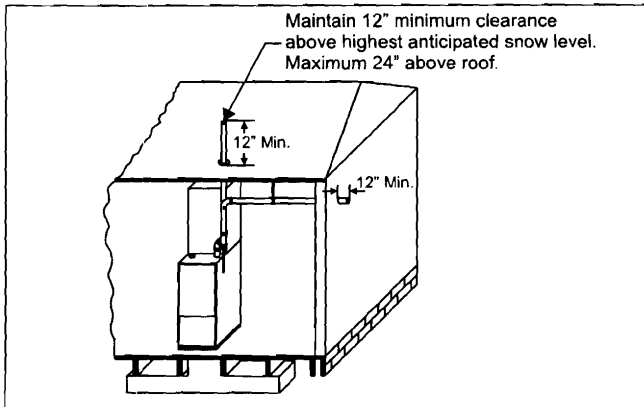

FIGURE 29: Termination Configuration - 1 Pipe

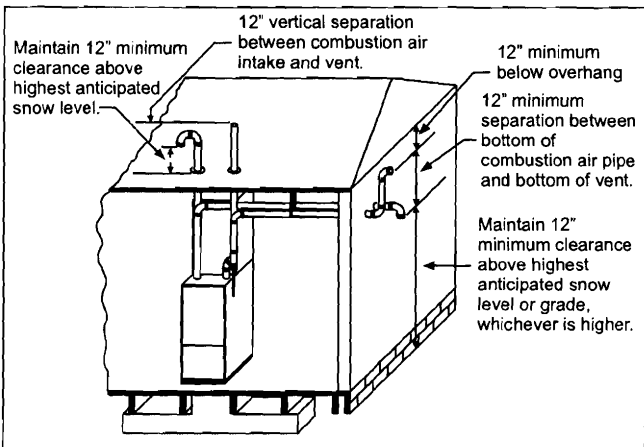

FIGURE 30: Termination Configuration - 2 Pipe

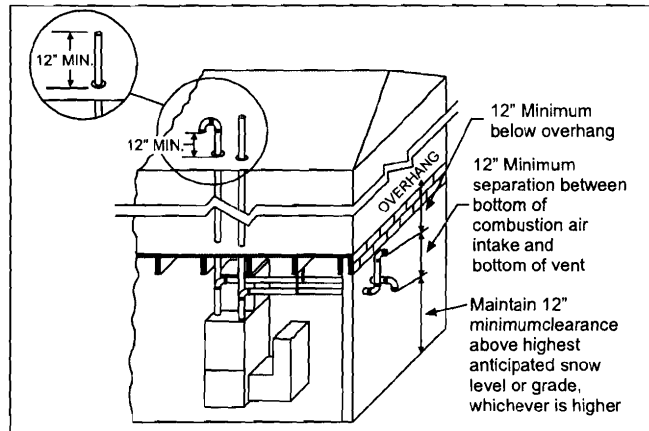

FIGURE 31: Termination Configuration - 2 Pipe Basement

VENTING MULTIPLE UNITS

Multiple units can be installed in a space or structure as either a single pipe configuration or a two-pipe configuration.

The combustion air side of the single pipe configuration shown in Figure 29 is referred to in these instructions as ambient combustion air supply. Follow the instructions for ambient combustion air installations, paying particular attention to the section on air source from inside the building. The vent for a single pipe system must be installed as specified in the venting section of these instructions with the vent terminating as shown in Figure 29. Each furnace must have a separate vent pipe. Under NO circumstances can the two vent pipes be tied together.

The combustion air side of the two-pipe configuration shown in Figure 30 can be installed so the combustion air pipe terminates as described in outdoor combustion air or ventilated combustion air sections in these instructions. Follow the instructions for outdoor combustion air or ventilated combustion air and the instructions for installing the vent system with the vent terminating as shown in Figures 32 or 33. The two-pipe system must have a separate combustion air pipe and a separate vent pipe for each furnace. Under NO circumstances can the two combustion air or vent pipes be tied together. The combustion air and vent pipes must terminate in the same atmospheric zone.

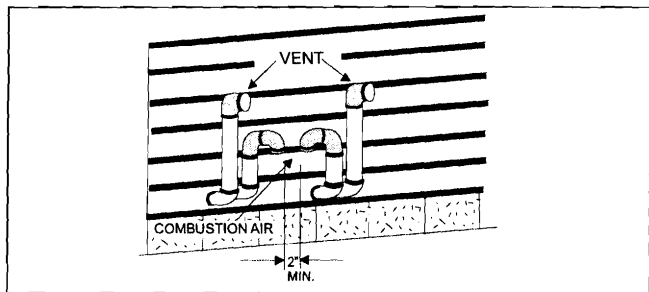

FIGURE 32: Double Horizontal Combustion Air Intake and Vent Termination

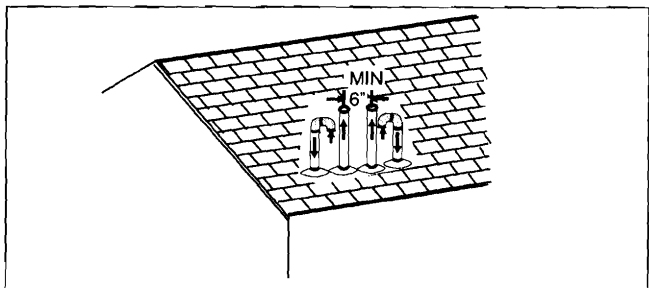

FIGURE 33: Double Vertical Combustion Air Intake and Vent Termination

COMBUSTION AIR SUPPLY

All installations must comply with Section 5.3, Air for Combustion and Ventilation of the National Fuel Gas Code, ANSI Z223.1 or Sections 7.2, 7.3 or 7.4 of CAN/CGA B149.1 or .2 Installation Code - latest editions.

This furnace is certified to be installed with one of three possible combustion air intake configurations.

1. **OUTDOOR COMBUSTION AIR:** This is a direct vent configuration where the combustion air is supplied through a PVC or ABS pipe that is connected to the PVC coupling attached to the furnace and is terminated in the same atmospheric zone as the vent. This type of installation is approved on all models. Refer to Figure 36.
2. **AMBIENT COMBUSTION AIR:** Combustion air is supplied from the area surrounding the furnace through openings in the furnace casing. The combustion air and the vent pipes are not terminated in the same atmospheric zone. Refer to Figure 21 for vent terminations. Refer to "Ambient Combustion Air Supply" for proper installation. Refer to Figure 36.
3. **VENTILATED COMBUSTION AIR:** Combustion air is supplied through a PVC or ABS pipe that is connected to the PVC coupling attached to the burner box and is terminated in a ventilated attic or crawl space. The combustion air and the vent pipes are not terminated in the same atmospheric zone. Refer to Figure 37 for attic and crawl space termination. Only the combustion air intake may terminate in the attic. The vent must terminate outside.

Outdoor Combustion Air

Combustion Air Intake/Vent Connections

This installation requires combustion air to be brought in from outdoors. This requires a properly sized pipe (Shown in Figure 30) that will bring air in from the outdoors to the furnace combustion air intake collar on the burner box. The second pipe (Shown in Figure 30) is the furnace vent pipe.

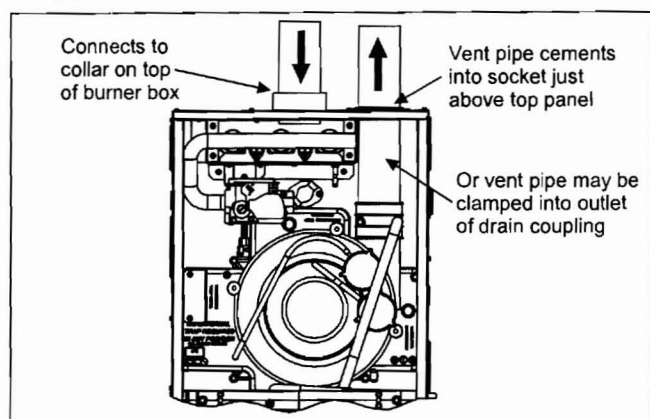

FIGURE 34: Direct Vent Air Intake Connection and Vent Connection

The combustion air intake pipe should be located either through the wall (horizontal or side vent) or through the roof (vertical vent). Care should be taken to locate side vented systems where trees or shrubs will not block or restrict supply air from entering the terminal.

Also, the terminal assembly should be located as far as possible from a swimming pool or a location where swimming pool chemicals might be stored. Be sure the terminal assembly follows the outdoor clearances listed in Section #1 "Outdoor Air Contaminants."

Ambient Combustion Air Supply

This type installation will draw the air required for combustion from within the space surrounding the appliance and from areas or rooms adjacent to the space surrounding the appliance. This may be from within the space in a non-confined location or it may be brought into the furnace area from outdoors through permanent openings or ducts. It is not piped directly into the furnace. A single, properly sized pipe from the furnace vent connector to the outdoors must be provided. It is recommended that the supplied intake coupling & 18" of pipe be attached to the furnace to prevent accidental blockage of the combustion air intake.

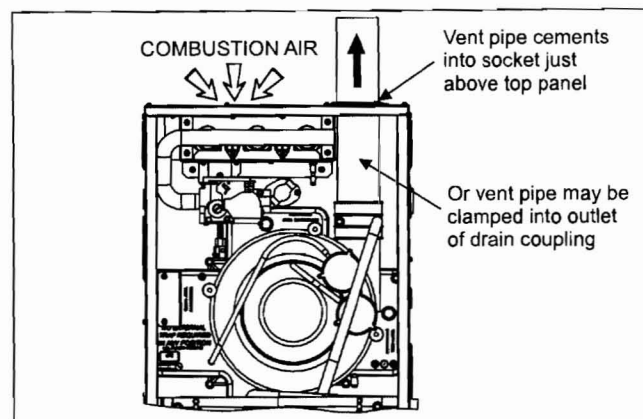

FIGURE 35: Combustion Airflow Path Through The Furnace Casing

WARNING

This type of installation requires that the supply air to the appliance(s) be of a sufficient amount to support all of the appliance(s) in the area. Operation of a mechanical exhaust, such as an exhaust fan, kitchen ventilation system, clothes dryer or fireplace may create conditions requiring special attention to avoid unsatisfactory operation of gas appliances. A venting problem or a lack of supply air will result in a hazardous condition, which can cause the appliance to soot and generate dangerous levels of CARBON MONOXIDE, which can lead to serious injury, property damage and / or death.

An **unconfined space** is not less than 50 cu.ft (1.42 m³) per 1,000 Btu/hr (0.2928 kW) input rating for all of the appliances installed in that area.

Rooms communicating directly with the space containing the appliances are considered part of the unconfined space, if doors are furnished with openings or louvers.

A **confined space** is an area with less than 50 cu.ft (1.42 m³) per 1,000 Btu/hr (0.2928 kW) input rating for all of the appliances installed in that area. The following must be considered to obtain proper air for combustion and ventilation in confined spaces.

Combustion Air Source From Outdoors

The blocking effects of louvers, grilles and screens must be given consideration in calculating free area. If the free area of a specific louver or grille is not known, refer to Table 11, to estimate free area.

Table 11: Estimated Free Area

Wood or Metal Louvers or Grilles	Wood 20-25%* Metal 60-70% *
Screens+	1/4" (0.635 cm) mesh or larger 100%

* Do not use less than 1/4" (0.635 cm) mesh

+ Free area of louvers and grille varies widely; the installer should follow louver or grille manufacturer's instructions.

Dampers, Louvers and Grilles (Canada Only)

1. The free area of a supply air opening shall be calculated by subtracting the blockage area of all fixed louvers grilles or screens from the gross area of the opening.
2. Apertures in a fixed louver, a grille, or screen shall have no dimension smaller than 0.25" (0.64 cm).
3. A manually operated damper or manually adjustable louvers are not permitted for use.
4. A automatically operated damper or automatically adjustable louvers shall be interlocked so that the main burner cannot operate unless either the damper or the louver is in the fully open position.

⚠ WARNING

When a Category I furnace is removed or replaced, the original venting system may no longer be correctly sized to properly vent the attached appliances.

An improperly sized vent system can cause CARBON MONOXIDE to spill into the living space causing personal injury, and or death.

Table 12: Unconfined Space Minimum Area in Square Inch

BTUH Input Rating	Minimum Free Area in Square Feet Required for Each Opening
40,000	40 (258 cm ²)
60,000	60 (387 cm ²)
80,000	80 (516 cm ²)
100,000	100 (645 cm ²)
120,000	120 (742 cm ²)
130,000	130 (838 cm ²)

Table 13: Free Area

BTUH Input Rating	Minimum Free Area Required for Each Opening		
	Horizontal Duct (2,000 BTUH)	Vertical Duct or Opening to Outside (4,000 BTUH)	Round Duct (4,000 BTUH)
40,000	20 in ² (129 cm ²)	10 in ² (64 cm ²)	4" (10 cm)
60,000	30 in ² (193 cm ²)	15 in ² (97 cm ²)	5" (13 cm)
80,000	40 in ² (258 cm ²)	20 in ² (129 cm ²)	5" (13 cm)
100,000	50 in ² (322 cm ²)	25 in ² (161 cm ²)	6" (15 cm)
120,000	60 in ² (387 cm ²)	30 in ² (193 cm ²)	7" (18 cm)
130,000	65 in ² (419 cm ²)	33 in ² (213 cm ²)	7" (18 cm)

EXAMPLE: Determining Free Area.

Appliance 1 Appliance 2 Total Input
 100,000 + 30,000 = (130,000 ÷ 4,000) = 32.5 Sq. In. Vertical

Appliance 1 Appliance 2 Total Input
 100,000 + 30,000 = (130,000 ÷ 2,000) = 65 Sq. In. Horizontal

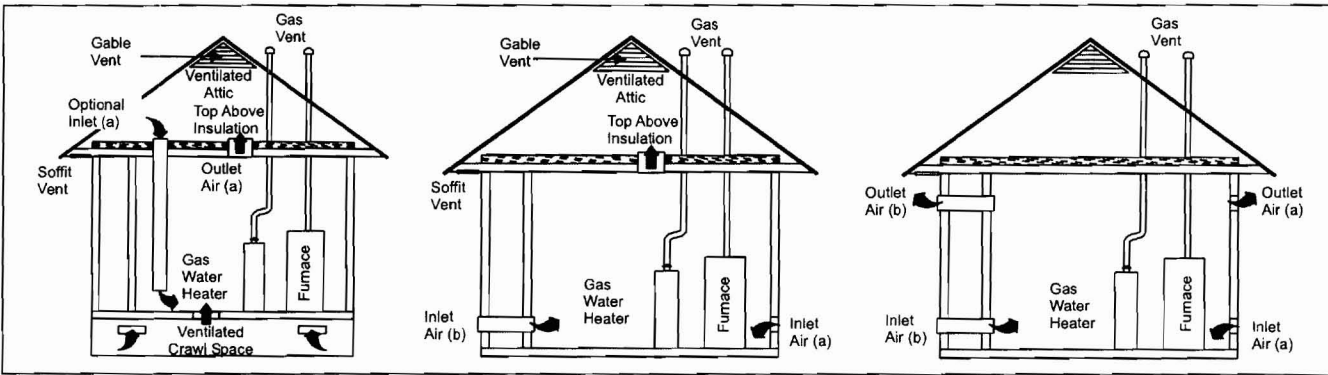

FIGURE 36: Outside and Ambient Combustion Air

Air Supply Openings and Ducts

1. An opening may be used in lieu of a duct to provide to provide the outside air supply to an appliance unless otherwise permitted by the authority having jurisdiction. The opening shall be located within 12" (30.5 cm) horizontally from, the burner level of the appliance. Refer to "AIR SOURCE FROM OUTDOORS AND VENT AND SUPPLY AIR SAFETY CHECK" in these instructions for additional information and safety check procedure.
2. The duct shall be either metal, or a material meeting the class 1 requirements of CAN4-S110 Standard for Air Ducts.
3. The duct shall be least the same cross-sectional area as the free area of the air supply inlet opening to which it connects.
4. The duct shall terminate within 12 in (30.5 cm) above, and within 24 in (61 cm) horizontally from, the burner level of the appliance having the largest input.
5. A square or rectangular shaped duct shall only be used when the required free area of the supply opening is 9 in² (58.06 cm²) or larger. When a square or rectangular duct is used, its small dimension shall not be less than 3 in (7.6 cm).
6. An air inlet supply from outdoors shall be equipped with a means to prevent the direct entry of rain and wind. Such means shall not reduce the required free area of the air supply opening.

7. An air supply inlet opening from the outdoors shall be located not less than 12" (30.5 cm) above the outside grade level.

Combustion Air Source from Outdoors

1. Two permanent openings, one within 12 in (30.5 mm) of the top and one within 12 in (30.5 mm) of bottom of the confined space, Two permanent openings, shall communicate directly or by means of ducts with the outdoors, crawl spaces or attic spaces.
2. One permanent openings, commencing within 12 in (30.5 mm) of the top of the enclosure shall be permitted where the equipment has clearances of at least 1 in (2.54 cm) from the sides and back and 6 in (15.24 cm) from the front of the appliance. The opening shall communicate directly with the outdoors and shall have a minimum free area of:
 - a. 1 square in per 3000 Btu per hour (6.45 cm³ per 0.879 kW) of the total input rating of all equipment located in the enclosure.
 - b. Not less than the sum of all vent connectors in the confined space.
3. The duct shall be least the same cross-sectional area as the free area of the air supply inlet opening to which it connects.
4. The blocking effects of louvers, grilles and screens must be given consideration in calculating free area. If the free area of a specific louver or grille is not known. Refer to Table 11, "Estimated Free Area".

BUILDING PERMIT INSPECTION PROCEDURES

Please call 874-8703 or 874-8693 (ONLY)

to schedule your inspections as agreed upon

Permits expire in 6 months, if the project is not started or ceases for 6 months.

The Owner or their designee is required to notify the inspections office for the following inspections and provide adequate notice. Notice must be called in 48-72 hours in advance in order to schedule an inspection:

By initializing at each inspection time, you are agreeing that you understand the inspection procedure and additional fees from a "Stop Work Order" and "Stop Work Order Release" will be incurred if the procedure is not followed as stated below.

A Pre-construction Meeting will take place upon receipt of your building permit.

 X Framing/Rough Plumbing/Electrical: Prior to Any Insulating or drywalling

 X Final/Certificate of Occupancy: Prior to any occupancy of the structure or use.

NOTE: There is a \$75.00 fee per inspection at this point.

Certificate of Occupancy is not required for certain projects. Your inspector can advise you if your project requires a Certificate of Occupancy. All projects DO require a final inspection.

If any of the inspections do not occur, the project cannot go on to the next phase, REGARDLESS OF THE NOTICE OR CIRCUMSTANCES.

CERIFICATE OF OCCUPANICES MUST BE ISSUED AND PAID FOR, BEFORE THE SPACE MAY BE OCCUPIED.



Signature of Applicant/Designee

 3/6/09
Date



Signature of Inspections Official

 3/5/09
Date

Ventilated Combustion Air

The ventilated attic space or a crawl space from which the combustion air is taken must comply with the requirements specified in "AIR SOURCE FROM OUTDOORS" in this instruction or in Section 5.3, Air for Combustion and Ventilation of the National Fuel Gas Code, ANSI Z223.1 (latest edition). This type installation requires two properly sized pipes. One brings combustion air from a properly ventilated attic space or crawl space and a second pipe that extends from the furnace vent connection (top right of unit) to the exterior of the building. Refer to Table 7, "Maximum Equivalent Pipe Length" for intake pipe sizing, allowable length and elbow usage. Follow all notes, procedures and required materials in the "COMBUSTION AIR/VENT PIPE SIZING" section in these instructions when installing the combustion air pipe from the unit and into a ventilated attic space or crawl space. **DO NOT** terminate vent pipe in an Attic or Crawl Space.

Ventilated Combustion Air Termination

Refer to Figure 37, "Attic and Crawl Space Combustion Air Termination" for required attic termination for the combustion air intake pipe. For attic termination, use two 90 elbows with the open end in a downward position. Be sure to maintain 12" (30 cm) clearance above any insulation, flooring or other material.

A crawl space combustion air installation consists of a straight pipe from the PVC coupling on the burner box that extends into the crawl space and terminates with a 1/4" (6.35 mm) mesh screen and no elbows.

WARNING

CARBON MONOXIDE POISONING HAZARD

Failure to follow the steps outlined below for each appliance connected to the venting system being placed into operation could result in carbon-monoxide poisoning or death.

The following steps shall be followed for each appliance connected to the venting system being placed into operation, while all other appliances connected to the venting system are not in operation:

1. Inspect the venting system for proper size and horizontal pitch. Determine that there is no blockage, restriction, leakage, corrosion or other deficiencies, which could cause an unsafe condition
2. Close all building doors and windows and all doors.
3. Turn on clothes dryers and **TURN ON** any exhaust fans, such as range hoods and bathroom exhausts, so they shall operate at maximum speed. Open the fireplace dampers. Do not operate a summer exhaust fan.
4. Follow the lighting instructions. Place the appliance being inspected in operation. Adjust thermostat so the appliance shall operate continuously.
5. Test each appliance (such as a water heater) equipped with a draft hood for spillage (down-draft or no draft) at the draft hood relief opening after 5 minutes of main burner operation. Appliances that do not have draft hoods need to be checked at the vent pipe as close to the appliance as possible. Use a combustion analyzer to check the CO₂ and CO levels of each appliance. Use a draft gauge to check for a downdraft or inadequate draft condition.
6. After it has been determined that each appliance properly vents when tested as outlined above, return doors, windows, exhaust fans, fireplace dampers and any other gas burning appliance to their normal condition.
7. If improper venting is observed during any of the above tests, a problem exists with either the venting system or the appliance does not have enough combustion air (Supply Air from outside) to complete combustion. This condition must be corrected before the appliance can function safely.

NOTE: An unsafe condition exists when the CO reading exceeds 40 ppm and the draft reading is not in excess of - 0.1 in. W.C. (-25 kPa) with all of the appliance(s) operating at the same time.

8. Any corrections to the venting system and / or to the supply (outside) air system must be in accordance with the National Fuel Gas Code Z223.1 or CAN/CGA B149.1 Natural Gas and Propane Installation Code (latest editions). If the vent system must be resized, follow the appropriate tables in Appendix G of the above codes or for this appliance.

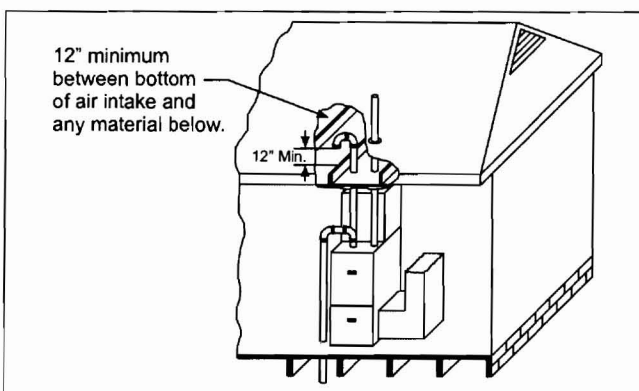

FIGURE 37: Attic and Crawl Space Combustion Air Termination

Specially Engineered Installations

The above requirements shall be permitted to be waived where special engineering, approved by the authority having jurisdiction, provides an adequate supply of air for combustion and ventilation.

WARNING

Be sure to instruct the owner not to block this intake pipe.

VENT BLOWER ROTATION

For ease of venting, the vent blower may be rotated 90° in either direction. For upflow installations the vent may exit through the top or either side of the cabinet. For downflow installations, the vent blower must be rotated so that the vent exits through either side of the cabinet. See Figures 23-26 for details.

City of Portland, Maine - Building or Use Permit

389 Congress Street, 04101 Tel: (207) 874-8703, Fax: (207) 874-8716

Permit No: 09-0131	Date Applied For: 02/18/2009	CBL: 425 A002001
------------------------------	--	----------------------------

Location of Construction: 125 PRESUMPCOT ST	Owner Name: PRESUMPCOT STREET PROPE	Owner Address: PO BOX 403	Phone:
Business Name:	Contractor Name: Coast Line Air	Contractor Address: PO Box 125 Westbrook	Phone (207) 232-0113
Lessee/Buyer's Name	Phone:	Permit Type: HVAC	

Proposed Use: Commercial - install a York/Coleman 90+Split system Hot air in attic - w/ 1000 gallon tank	Proposed Project Description: install a York/Coleman 90+Split system Hot air in attic - w/ 1000 gallon tank
--	---

Dept: Zoning	Status: Approved with Conditions	Reviewer: Marge Schmuckal	Approval Date: 02/19/2009
Note:			Ok to Issue: <input checked="" type="checkbox"/>
1) No determination as to zoning use has been made with this application. Any change of uses from those that have been previously approved in the past by means of permit are required to submit a change of use permit application.			
Dept: Building	Status: Approved with Conditions	Reviewer: Jeanine Bourke	Approval Date: 03/05/2009
Note:			Ok to Issue: <input checked="" type="checkbox"/>
1) Installation shall comply with 2003 International Mechanical Code			
Dept: Fire	Status: Approved with Conditions	Reviewer: Capt Keith Gautreau	Approval Date: 02/26/2009
Note:			Ok to Issue: <input checked="" type="checkbox"/>
1) Install shall comply with all manufacture's specifications.			
2) Install shall comply with NFPA 58 A compliance letter is required.			

Comments:
3/5/2009-jmb: Left vmsg with Earle R. For details on weight of units in attic and ductwork. Earle called back to confirm that the new attic storage area is 2x10 joists and the HVAC units will also be mounted to the exterior wall. Similar as in a previous tenant space. Ductwork will be installed from the unit.



05/20/09 Closed *JMS*



CITY OF PORTLAND, MAINE

Department of Building Inspections

Original Receipt

7.19 2009

Received from SMAI

Location of Work 175 PR-SAPSLO++

Cost of Construction \$ _____ Building Fee: _____

Permit Fee \$ 355 Site Fee: _____

Certificate of Occupancy Fee: _____

Total: 355

Building (I1) Plumbing (I5) Electrical (I2) Site Plan (U2)

Other HVAC + TANK

CBL: 425A2

Check #: CC Total Collected \$ 355

No work is to be started until permit issued.

If permit is Withdrawn or Denied, amount of the Refund is based on \$20.00 or 20% of the fee, (whichever is greater)

In order to receive a refund, you **MUST** present the Original Receipt.

Taken by: [Signature]

WHITE - Applicant's Copy

YELLOW - Office Copy

PINK - Permit Copy