

DISPLAY THIS CARD ON PRINCIPAL FRONTAGE OF WORK
CITY OF PORTLAND

Please Read
Application And
Notes, If Any,
Attached

BUILDING INSPECTION

PERMIT

PERMIT ISSUED Permit Number: 080382 MAY 7 2008 CITY OF PORTLAND

This is to certify that KELLEY CHARLES E VNIANT & SALLY E KELLEY JTS owner

has permission to Remove existing deck & replace w/new deck & tie foot print

AT 13 WELLSTONE unit 13

423 A005018

provided that the person or persons, firm or corporation accepting this permit shall comply with all of the provisions of the Statutes of Maine and of the Ordinances of the City of Portland regulating the construction, maintenance and use of buildings and structures, and of the application on file in this department.

Apply to Public Works for street line and grade if nature of work requires such information.

Notification of inspection must be given and when permission procured before this building or part thereof is started or closed-in.
 HOUR NOTICE IS REQUIRED.

A certificate of occupancy must be procured by owner before this building or part thereof is occupied.

OTHER REQUIRED APPROVALS

Fire Dept. _____

Health Dept. _____

Appeal Board _____

Other _____

Department Name

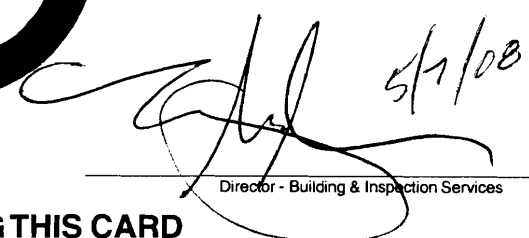
 Director - Building & Inspection Services

PENALTY FOR REMOVING THIS CARD

City of Portland, Maine - Building or Use Permit Application
 389 Congress Street, 04101 Tel: (207) 874-8703, Fax: (207) 874-8716

Permit No: 08-0382	Issue Date:	CBL: 423 A005013
-----------------------	-------------	---------------------

Location of Construction: 13 WELLSTONE unit 13	Owner Name: KELLEY CHARLES E VN VET &	Owner Address: 695 OCEAN AVE APT 13	Phone:
Business Name:	Contractor Name: Maine Properties, Inc.	Contractor Address: PO Box 368 Scarborough	Phone 2078833753
Lessee/Buyer's Name	Phone:	Permit Type: Additions - Multi Family	Zone: R-5

Past Use: Multi Condo Unit 13-	Proposed Use: Multi Condo Unit 13- Remove existing deck & replace w/new PT deck same foot print	Permit Fee: \$40.00	Cost of Work: \$1,500.00	CEO District: 4	Zone: R-5
Proposed Project Description: Remove existing deck & replace w/new PT deck same foot print <i>legal use: 72 Residential D.U.</i>		FIRE DEPT: <input type="checkbox"/> Approved <input type="checkbox"/> Denied Signature: <i>[Signature]</i>		INSPECTION: Use Group: <i>R-3</i> Type: <i>SB</i> <i>IBC 2003</i> Signature: <i>[Signature]</i>	
		PEDESTRIAN ACTIVITIES DISTRICT (P.A.D.) Action: <input type="checkbox"/> Approved <input type="checkbox"/> Approved w/Conditions <input type="checkbox"/> Denied Signature: _____ Date: _____			

Permit Taken By: ldobson	Date Applied For: 04/22/2008	Zoning Approval		
1. This permit application does not preclude the Applicant(s) from meeting applicable State and Federal Rules. 2. Building permits do not include plumbing, septic or electrical work. 3. Building permits are void if work is not started within six (6) months of the date of issuance. False information may invalidate a building permit and stop all work..		Special Zone or Reviews <input type="checkbox"/> Shoreland <input type="checkbox"/> Wetland <input type="checkbox"/> Flood Zone <input type="checkbox"/> Subdivision <input type="checkbox"/> Site Plan Maj <input type="checkbox"/> Minor <input type="checkbox"/> MM <input type="checkbox"/>	Zoning Appeal <input type="checkbox"/> Variance <input type="checkbox"/> Miscellaneous <input type="checkbox"/> Conditional Use <input type="checkbox"/> Interpretation <input type="checkbox"/> Approved <input type="checkbox"/> Denied	Historic Preservation <input checked="" type="checkbox"/> Not in District or Landmark <input type="checkbox"/> Does Not Require Review <input type="checkbox"/> Requires Review <input type="checkbox"/> Approved <input type="checkbox"/> Approved w/Conditions <input type="checkbox"/> Denied
		Date: <i>4/25/08</i>	Date: <i>4/25/08</i>	Date: <i>[Signature]</i>

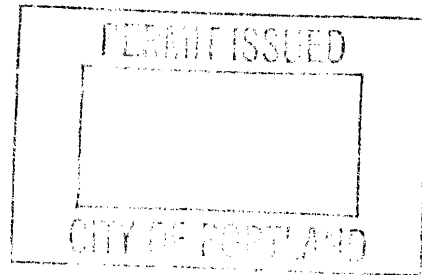

CERTIFICATION

I hereby certify that I am the owner of record of the named property, or that the proposed work is authorized by the owner of record and that I have been authorized by the owner to make this application as his authorized agent and I agree to conform to all applicable laws of this jurisdiction. In addition, if a permit for work described in the application is issued, I certify that the code official's authorized representative shall have the authority to enter all areas covered by such permit at any reasonable hour to enforce the provision of the code(s) applicable to such permit.

SIGNATURE OF APPLICANT	ADDRESS	DATE	PHONE
RESPONSIBLE PERSON IN CHARGE OF WORK, TITLE		DATE	PHONE

City of Portland, Maine - Building or Use Permit

389 Congress Street, 04101 Tel: (207) 874-8703, Fax: (207) 874-8716

Permit No: 08-0382	Date Applied For: 04/22/2008	CBL: 423 A005013
------------------------------	--	----------------------------

Location of Construction: 13 WELLSTONE unit 13	Owner Name: KELLEY CHARLES E VN VET &	Owner Address: 695 OCEAN AVE APT 13	Phone:
Business Name:	Contractor Name: Maine Properties, Inc.	Contractor Address: PO Box 368 Scarborough	Phone (207) 883-3753
Lessee/Buyer's Name	Phone:	Permit Type: Additions - Multi Family	

Proposed Use: Multi Condo Unit 13- Remove existing deck & replace w/new PT deck same foot print	Proposed Project Description: Remove existing deck & replace w/new PT deck same foot print
---	--

Dept: Zoning	Status: Approved with Conditions	Reviewer: Marge Schmuckal	Approval Date: 04/23/2008
Note: 1984 PRUD standards - legal use: 72 residential condos			Ok to Issue: <input checked="" type="checkbox"/>
1) This permit is being approved on the basis of plans submitted. Any deviations shall require a separate approval before starting that work.			
Dept: Building	Status: Approved	Reviewer:	Approval Date:
Note:			Ok to Issue: <input type="checkbox"/>

BUILDING PERMIT INSPECTION PROCEDURES

Please call 874-8703 or 874-8693 (ONLY)

to schedule your inspections as agreed upon

Permits expire in 6 months, if the project is not started or ceases for 6 months.

The Owner or their designee is required to notify the inspections office for the following inspections and provide adequate notice. Notice must be called in 48-72 hours in advance in order to schedule an inspection:

By initializing at each inspection time, you are agreeing that you understand the inspection procedure and additional fees from a "Stop Work Order" and "Stop Work Order Release" will be incurred if the procedure is not followed as stated below.

A Pre-construction Meeting will take place upon receipt of your building permit.

 X Footing/Building Location Inspection: Prior to pouring concrete or setting precast piers

 X Framing/Rough Plumbing/Electrical: Prior to Any Insulating or drywalling

 X Final inspection required at completion of work.

Certificate of Occupancy is not required for certain projects. Your inspector can advise you if your project requires a Certificate of Occupancy. All projects DO require a final inspection.

If any of the inspections do not occur, the project cannot go on to the next phase, REGARDLESS OF THE NOTICE OR CIRCUMSTANCES.

CERIFICATE OF OCCUPANICES MUST BE ISSUED AND PAID FOR, BEFORE THE SPACE MAY BE OCCUPIED

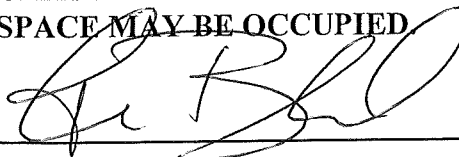

Signature of Applicant/Designee

 5/8/08

Date

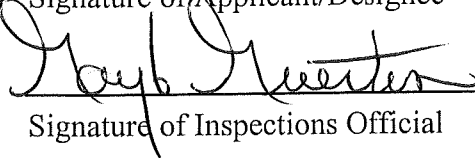

Signature of Inspections Official

 5/8/08

Date

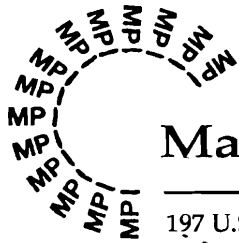

Maine Properties, Inc.

197 U.S. Route 1, P.O. Box 368, Scarborough, ME 04070-0368

207 / 883-3753

Fax • 207 / 883 - 0364

BEAM LOCATION & STRINGER DETAIL

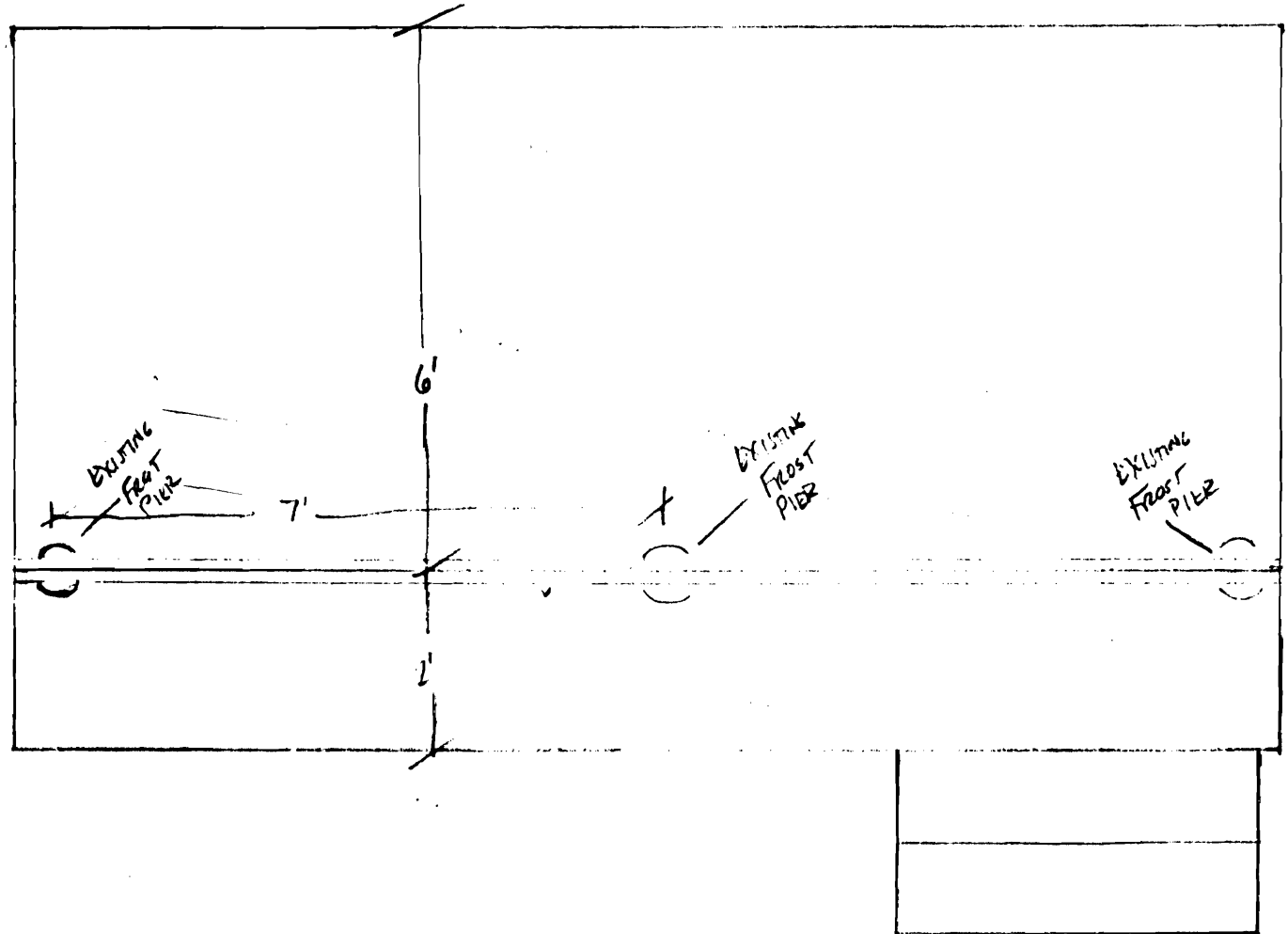

$\frac{1}{2}'' = 1'-0''$

13 WELLSTONE

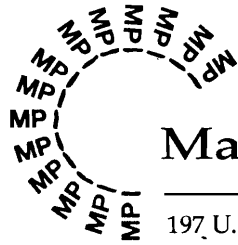

Maine Properties, Inc.

197 U.S. Route 1, P.O. Box 368, Scarborough, ME 04070-0368

207 / 883-3753

Fax • 207 / 883 - 0364

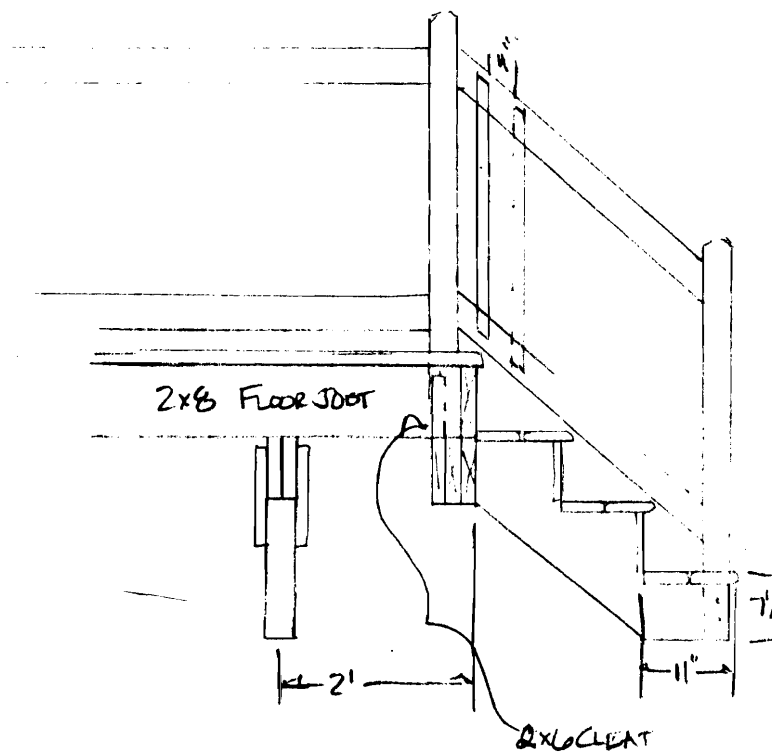

STAIR CROSS SECTION
1/2" = 1'-0"

FOR ALL WELLSTONE DECKS



General Building Permit Application

If you or the property owner owes real estate or personal property taxes or user charges on any property within the City, payment arrangements must be made before permits of any kind are accepted.

Location/Address of Construction: <u>13 Wellstone Drive</u>		
Total Square Footage of Proposed Structure/Area <u>104</u>		Square Footage of Lot
Tax Assessor's Chart, Block & Lot Chart# Block# Lot# <u>423</u> <u>A</u> <u>005-013</u>	Applicant * must be owner, Lessee or Buyer* Name <u>Maine Properties c/o</u> <u>Wellstone Condominium Ass.</u> Address <u>Wellstone Drive</u> City, State & Zip <u>Portland, Me 04103</u>	Telephone: <u>Pete Garrett</u> <u>883-3753</u> (Property Manager)
Lessee/DBA (If Applicable)	Owner (if different from Applicant) Name <u>Charles & Sally Kelley</u> Address <u>13 Wellstone Drive</u> City, State & Zip <u>Portland, Me 04103</u>	Cost Of Work: \$ <u>1,500</u> C of O Fee: \$ _____ Total Fee: \$ <u>40</u>
Current legal use (i.e. single family) <u>Condominium Single family Townhouse</u> If vacant, what was the previous use? _____ Proposed Specific use: <u>Recreation (Deck)</u> Is property part of a subdivision? <u>Yes Condo</u> If yes, please name <u>Wellstone Drive</u> Project description: <u>Remove existing deck and replace w/new P.T. Deck same</u> <u>Size as original (replacing due to rott)</u>		
Contractor's name: <u>Maine Properties Inc</u> Address: <u>PO Box 368 / 197 US Rt 1</u> City, State & Zip <u>Scarborough, Me 04070</u> Telephone: <u>883-3753</u> Who should we contact when the permit is ready: <u>TRANS BLAKE</u> Telephone: <u>415-3450</u> Mailing address: <u>PO Box 368 Scarborough Me 04074</u>		

Please submit all of the information outlined on the applicable Checklist. Failure to do so will result in the automatic denial of your permit.

In order to be sure the City fully understands the full scope of the project, the Planning and Development Department may request additional information prior to the issuance of a permit. For further information or to download copies of this form and other applications visit the Inspections Division on-line at www.portlandmaine.gov, or stop by the Inspections Division office, room 315 City Hall or call 874-8703.

I hereby certify that I am the Owner of record of the named property, or that the owner of record authorizes the proposed work and that I have been authorized by the owner to make this application as his/her authorized agent. I agree to conform to all applicable laws of this jurisdiction. In addition, if a permit for work described in this application is issued, I certify that the Code Official's authorized representative shall have the authority to enter all areas covered by this permit at any reasonable hour to enforce the provisions of the codes applicable to this permit.

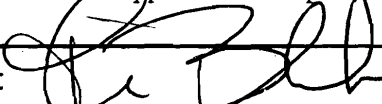
Signature:  Date: 4/22/08

This is not a permit; you may not commence ANY work until the permit is issued.

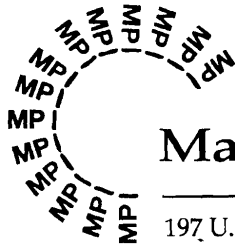

Maine Properties, Inc.

197 U.S. Route 1, P.O. Box 368, Scarborough, ME 04070-0368

207 / 883-3753

Fax • 207 / 883 - 0364

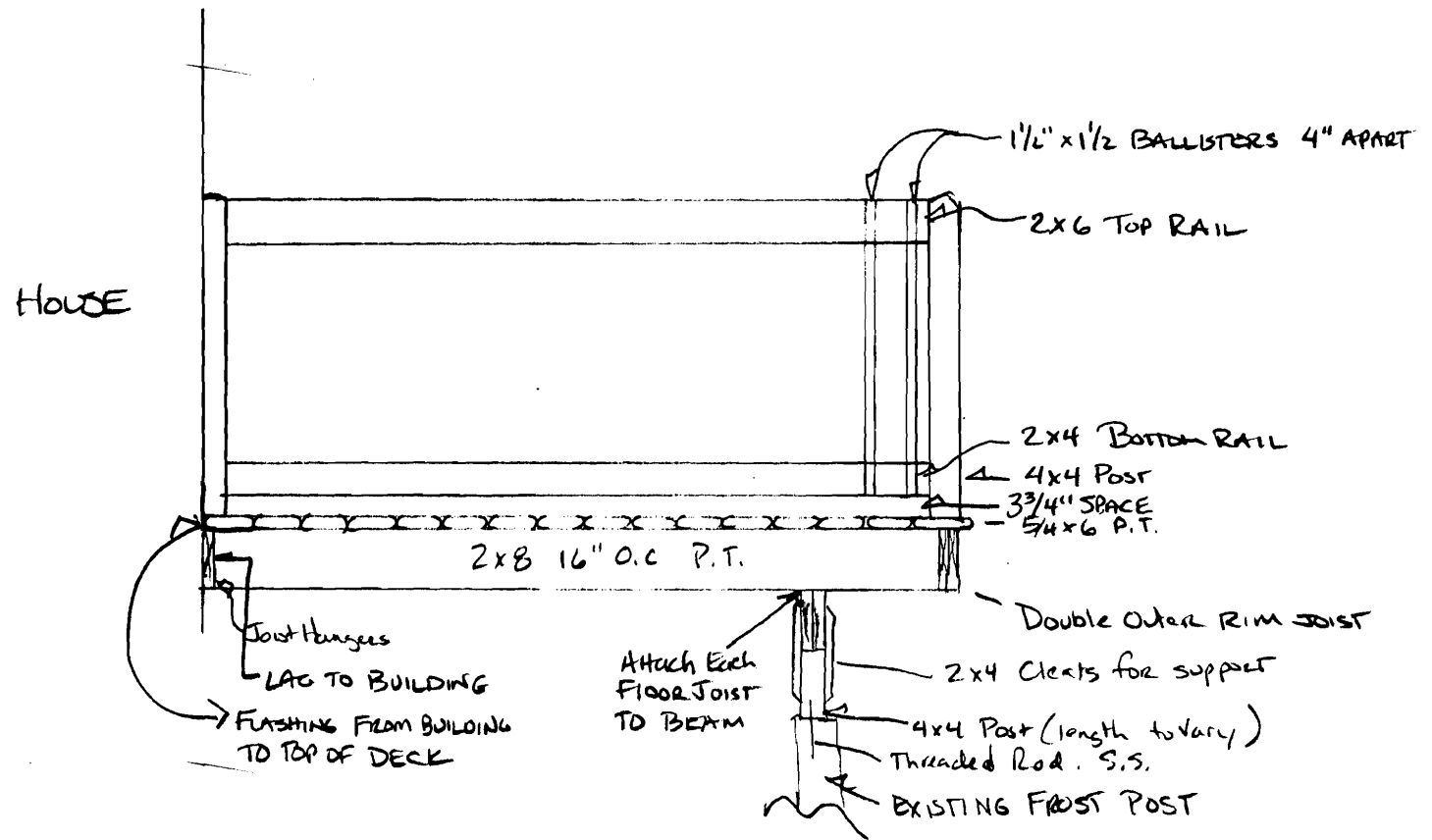

WELLSTONE DRIVE
1/2" = 1'-0"

PROJECT MANAGER = TRAVIS BLAKE
CONTACT # 415-3450

SCOPE OF WORK:
DEMO EXISTING DECK
CONSTRUCT NEW
SAME FOOTPRINT

Seigel

WELSTONE DRIVE
MAINE PROPERTIES INC
DECK REPLACEMENT
3,4,9,12,13,18,19,20,21,45

Front
Originally developed
under the old R-5
Prod Standards
that req. 12' side
setback
16' + Slope

