

**TYP. PAVED PARKING LOT SECTION**  
NOT TO SCALE

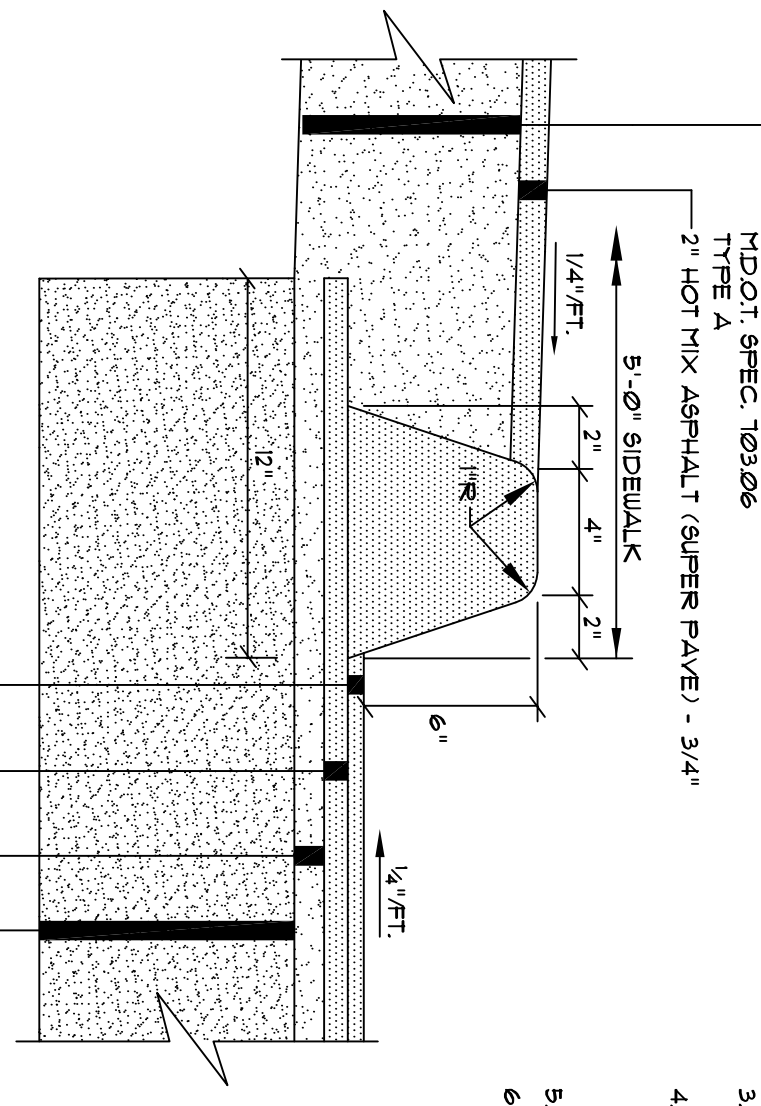

**BITUMINOUS CURB / SIDEWALK SECTION**  
NOT TO SCALE

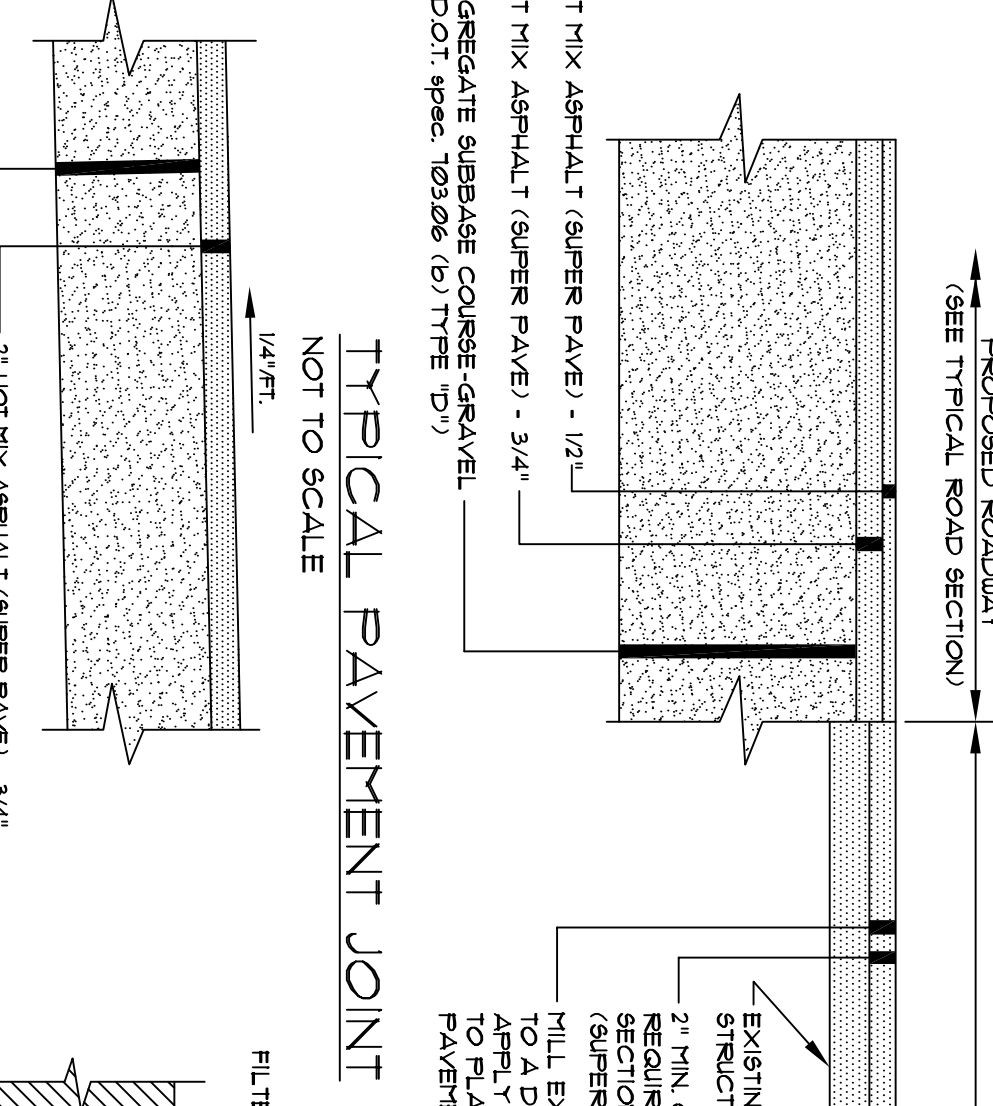

**TYPICAL PAVEMENT JOINT**  
NOT TO SCALE

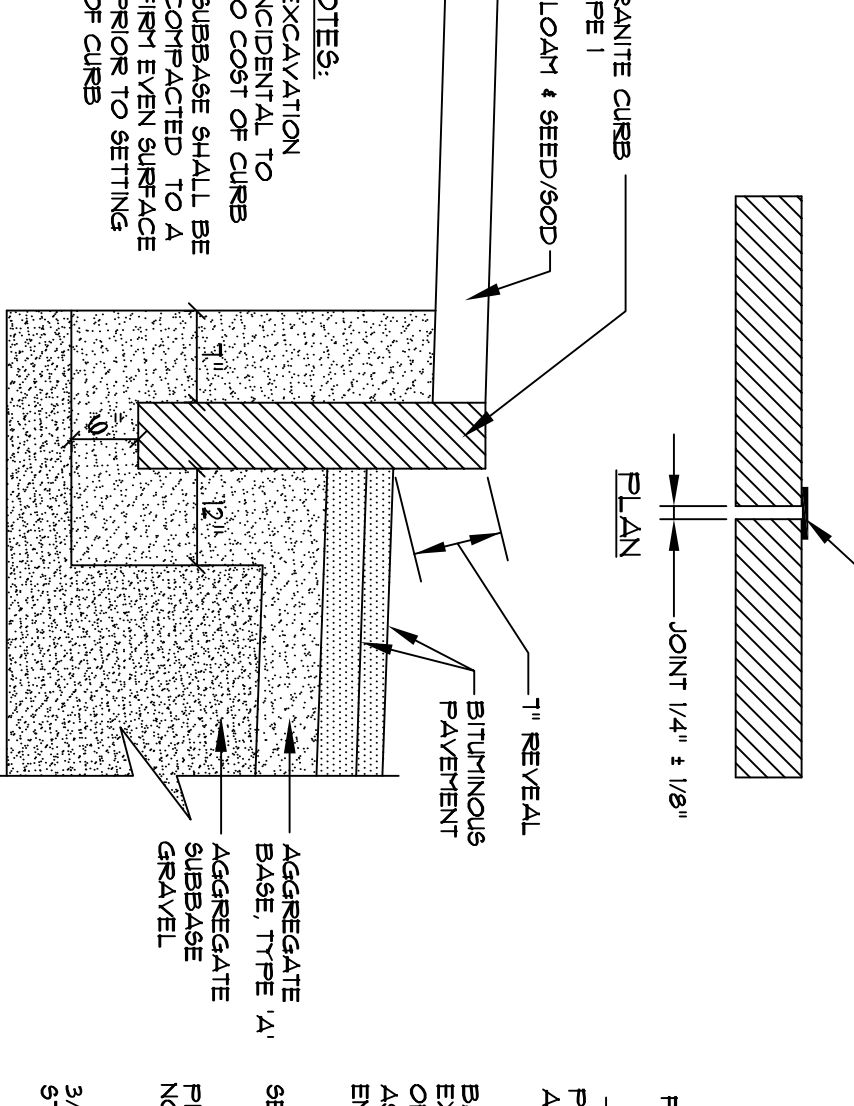

**BITUMINOUS SIDEWALK**  
NOT TO SCALE

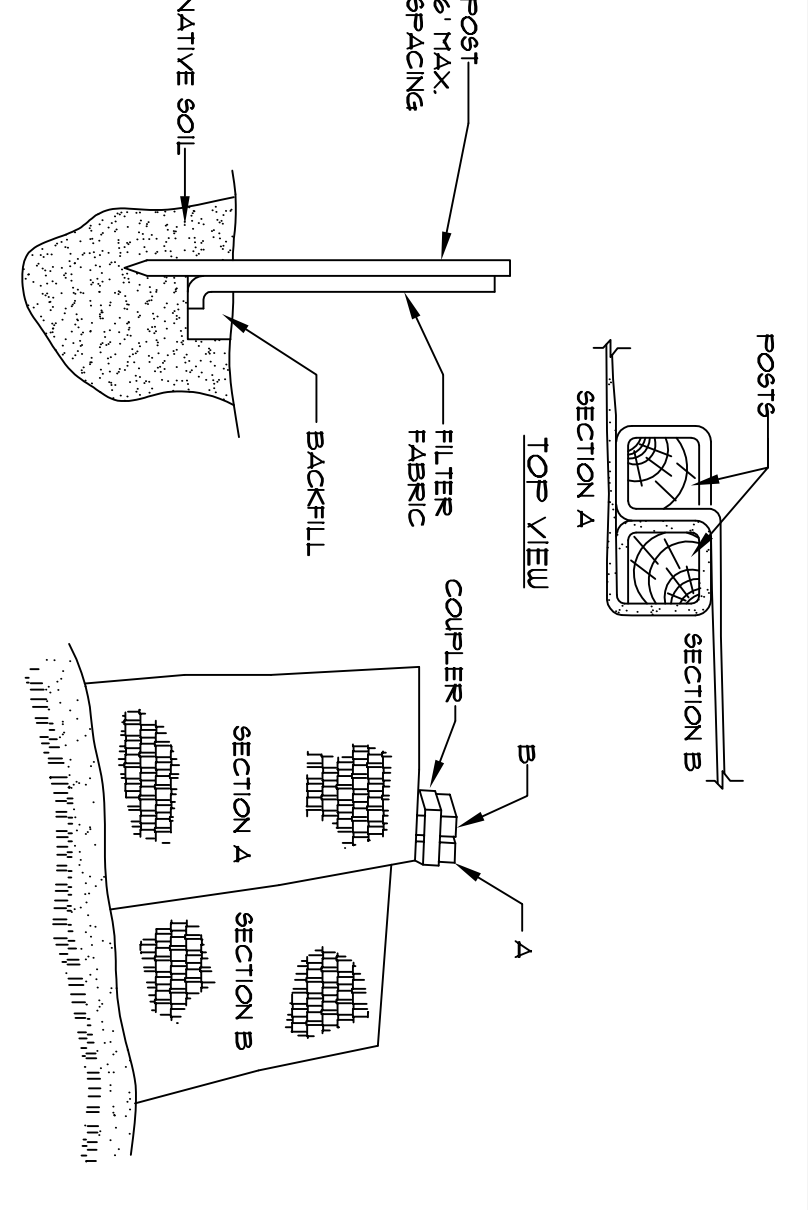

**INSTALLATION**  
**INSTALLATION**  
1. EXCAVATE A 6" X 6" TRENCH ALONG THE LINE OF PLACEMENT FOR THE FILTER BARRIER...  
**INSTALLATION**  
1. EXCAVATE A 6" X 6" TRENCH ALONG THE LINE OF PLACEMENT FOR THE FILTER BARRIER...  
2. UNROLL A SECTION AT A TIME AND POSITION THE POSTS AGAINST THE BACK (DOWNSTREAM) WALL OF THE TRENCH.  
3. DRIVE POSTS INTO THE GROUND UNTIL APPROXIMATELY 2" OF FABRIC IS LYING ON THE TRENCH BOTTOM.  
4. LAY THE JOINT FABRIC ON THE UNDISTURBED BOTTOM OF THE TRENCH. BACKFILL THE TRENCH AND TAMP THE SOIL TO THE TOP OF THE TRENCH. THE JOINT FABRIC SHALL BE ACCOMPANIED BY AN INTERCEPTION DITCH.  
5. JOINT SECTION AS SHOWN ABOVE.  
6. BARRIER SHALL BE INSTALLED 6" ABOVE.

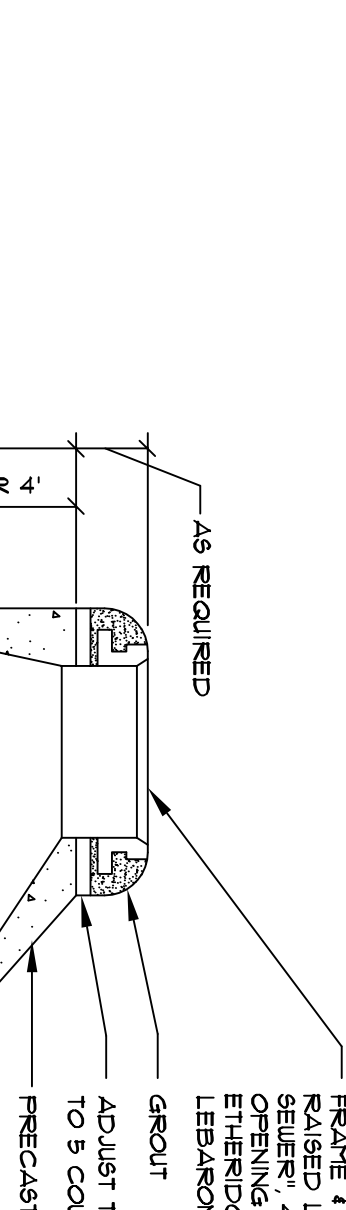

**PRECAST MANHOLE**  
NOT TO SCALE

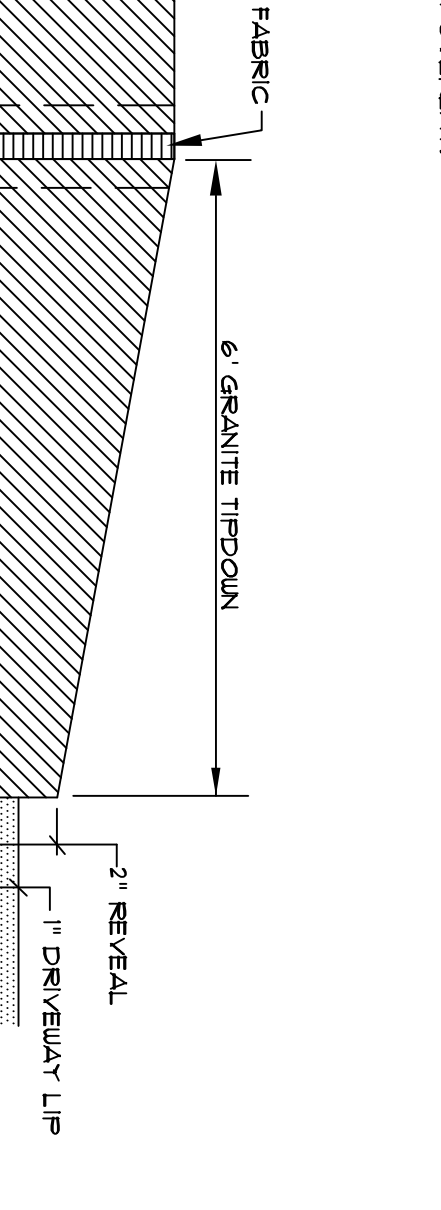

**TYPICAL TIPDOWN CURB INSTALLATION**  
NOT TO SCALE

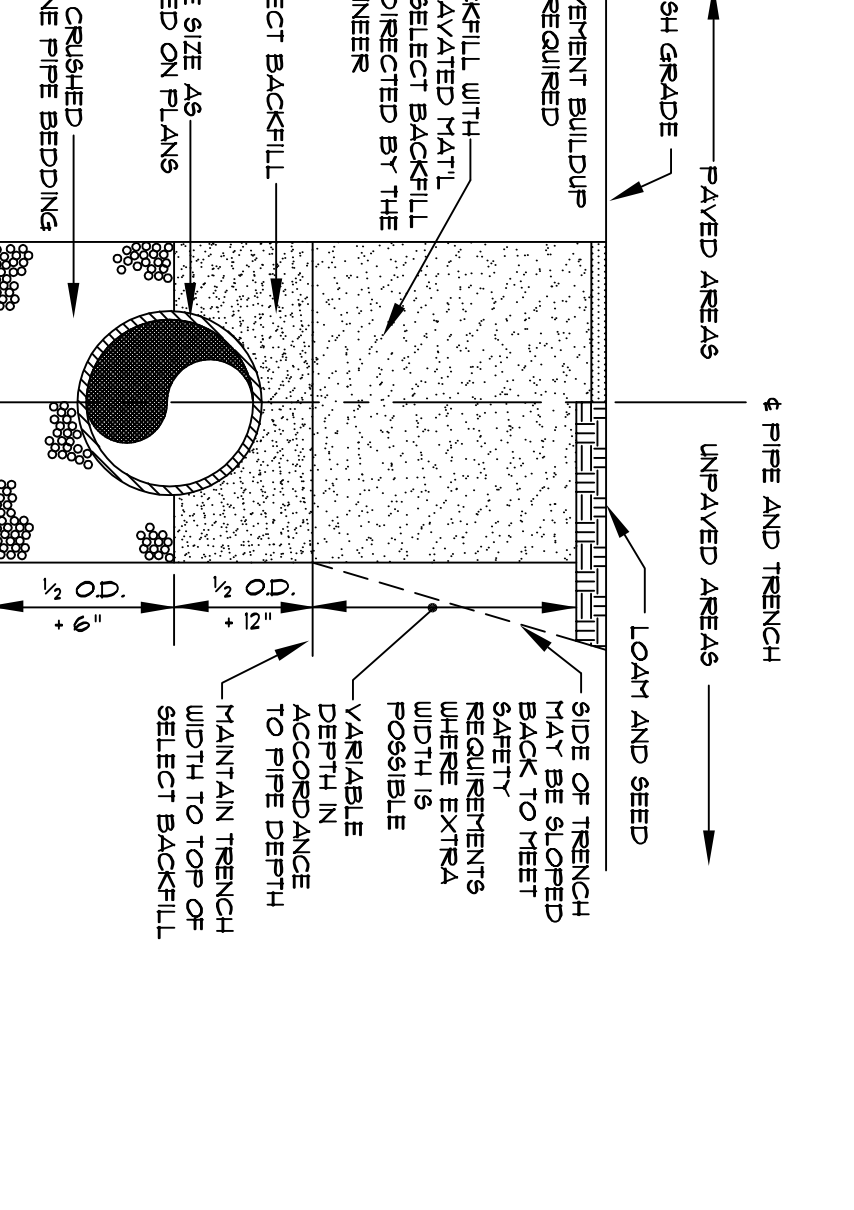

**TYPICAL TRENCH SECTION**  
NOT TO SCALE

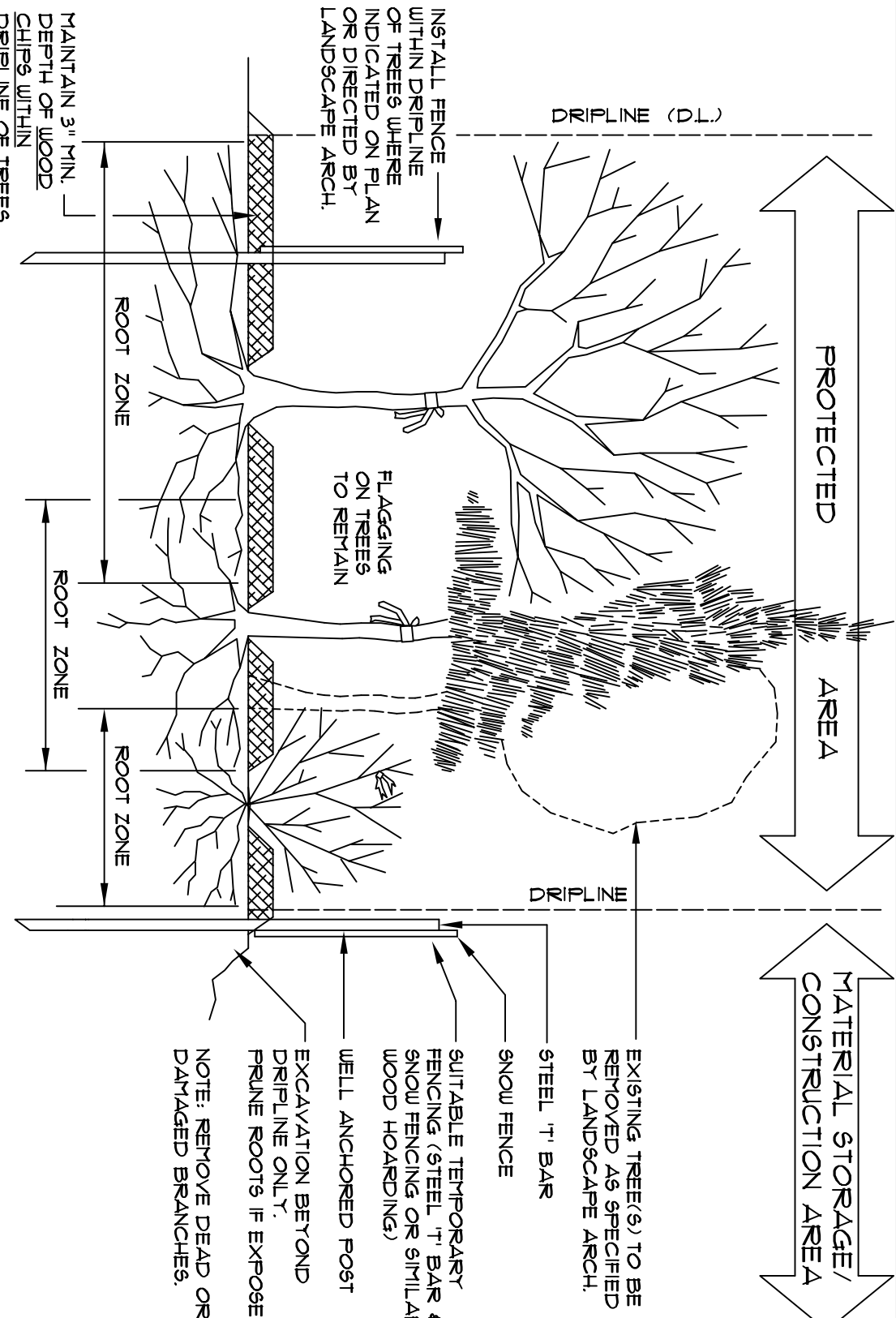

**TREE PROTECTION DETAIL**  
NOT TO SCALE

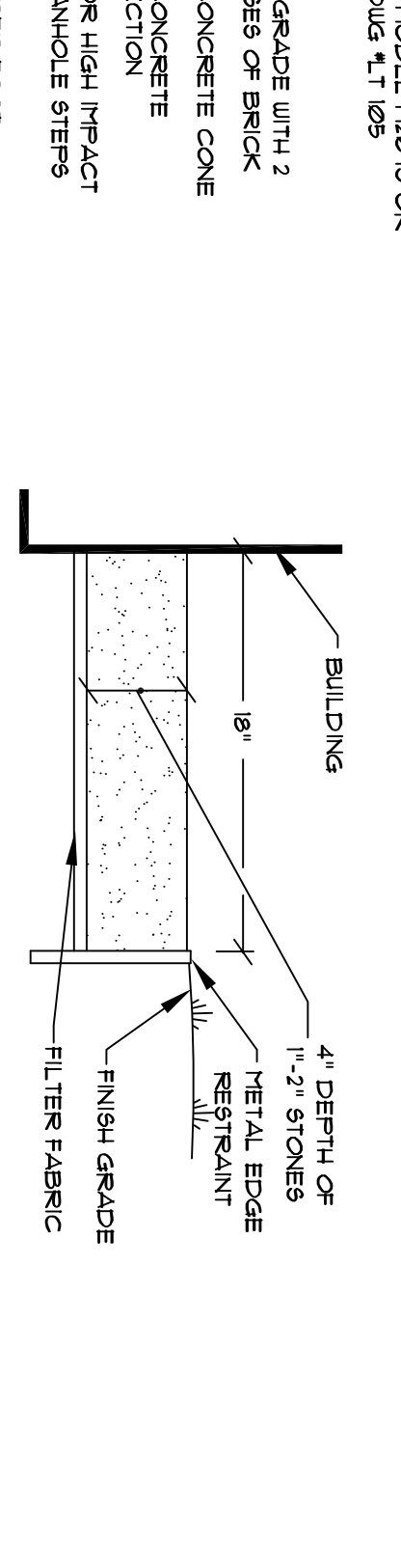

**STONE DRIP EDGE**  
NOT TO SCALE

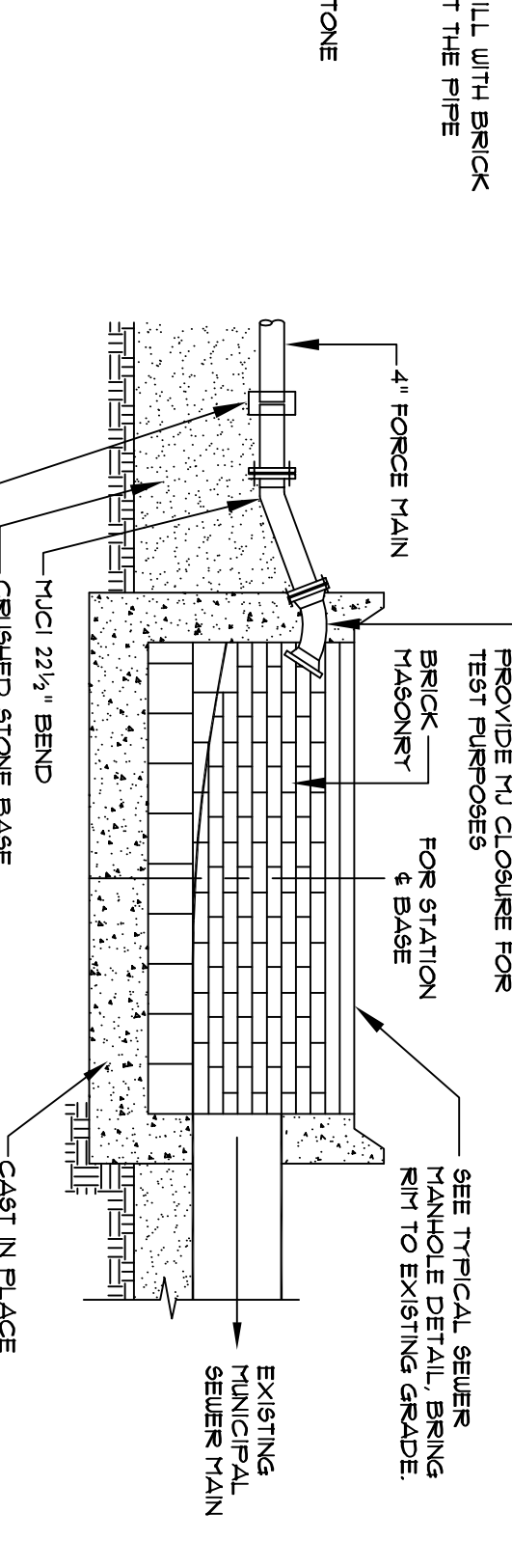

**FORCE MAIN TERMINUS MANHOLE**  
NOT TO SCALE

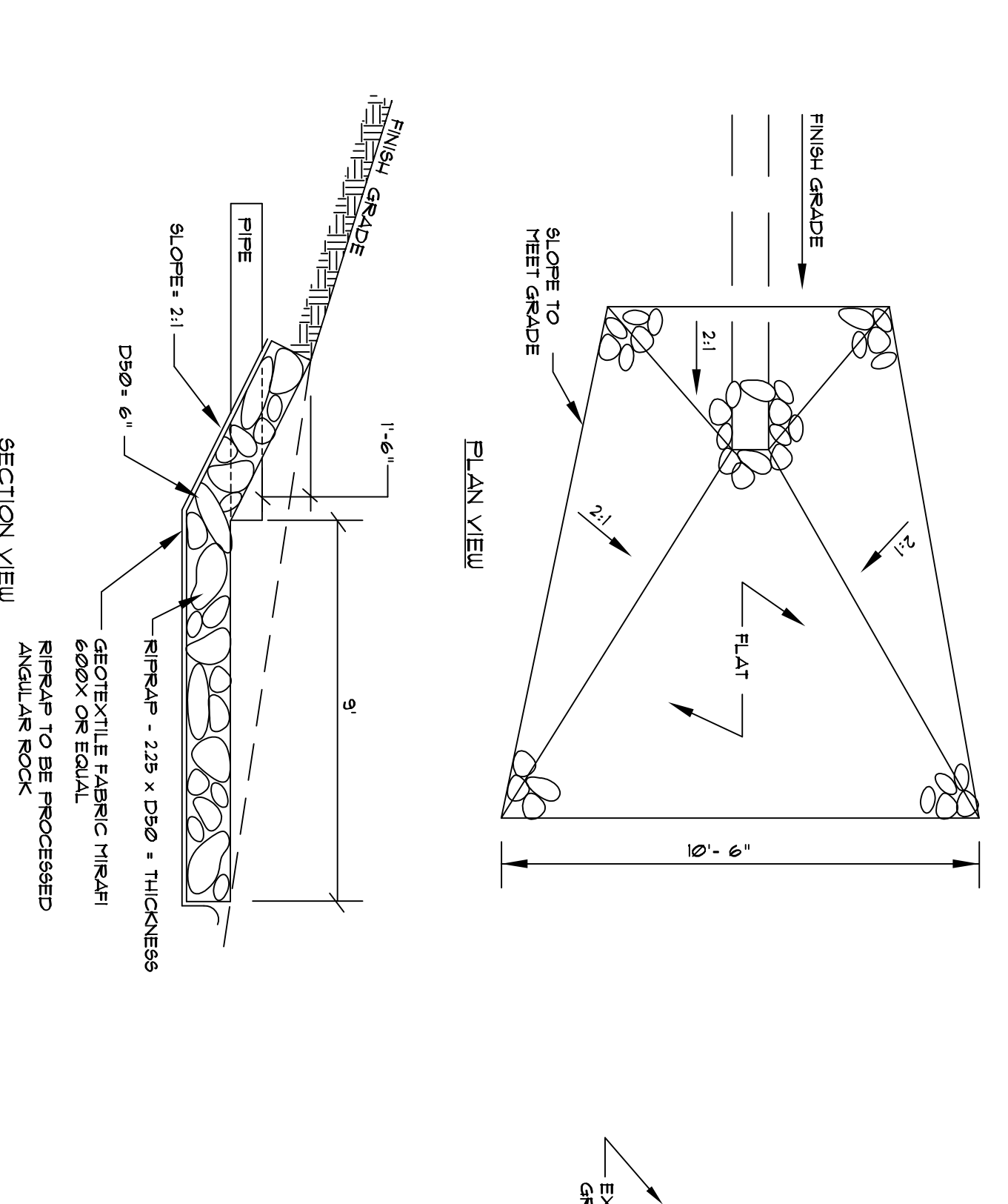

**RIPRAP APRON**  
NOT TO SCALE

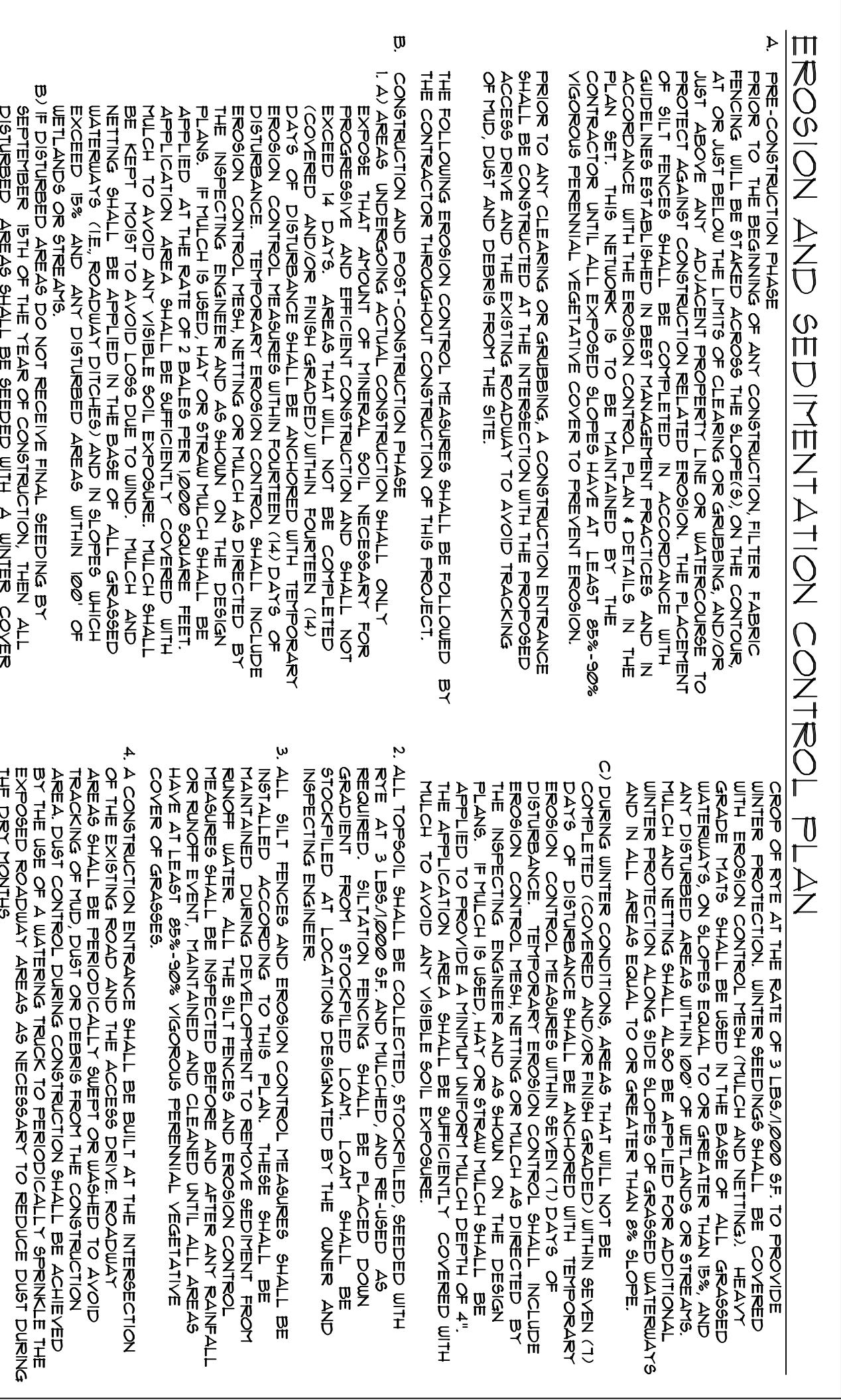

**EROSION AND SEDIMENTATION CONTROL PLAN**  
NOT TO SCALE

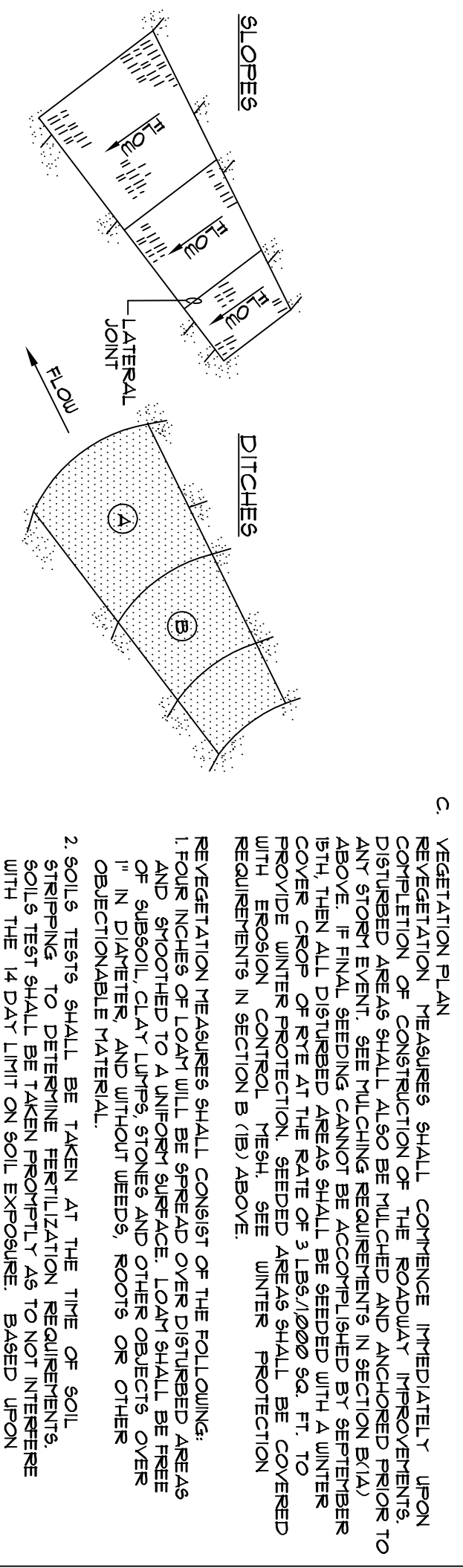

**EROSION CONTROL BLANKET**  
NOT TO SCALE

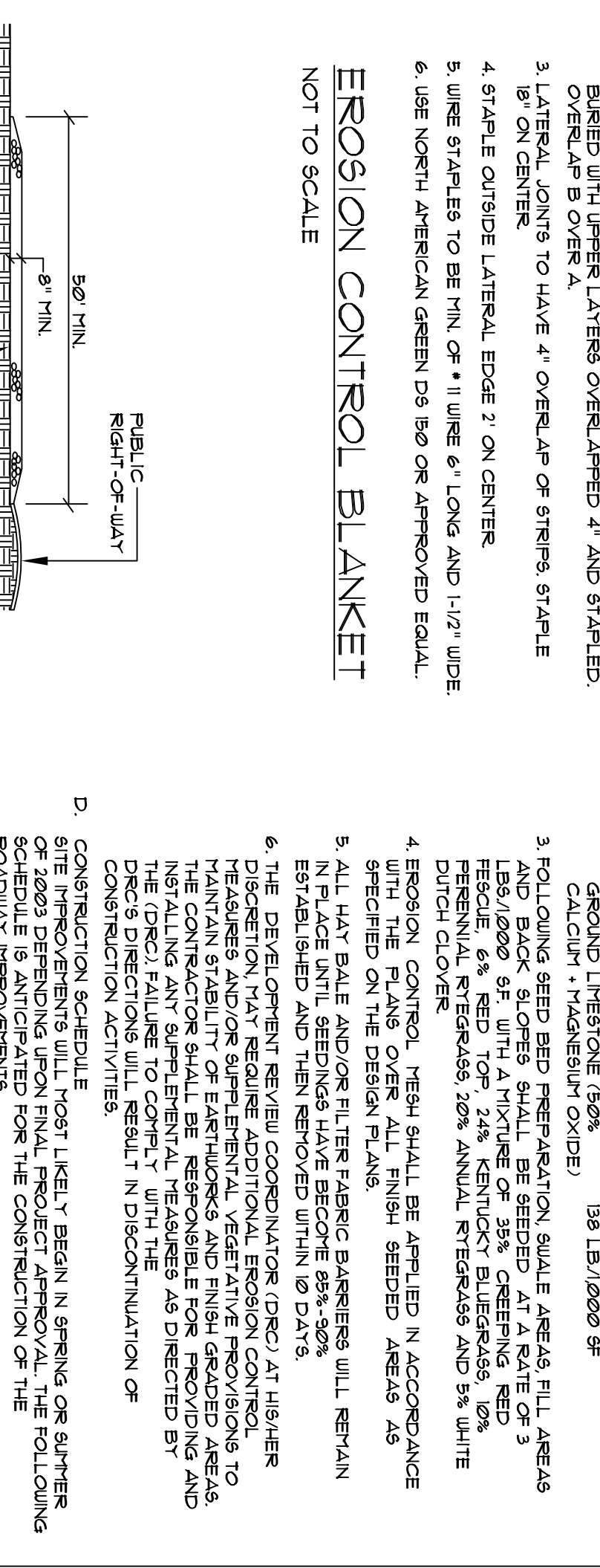

**STABILIZED CONSTRUCTION ENTRANCE**  
NOT TO SCALE

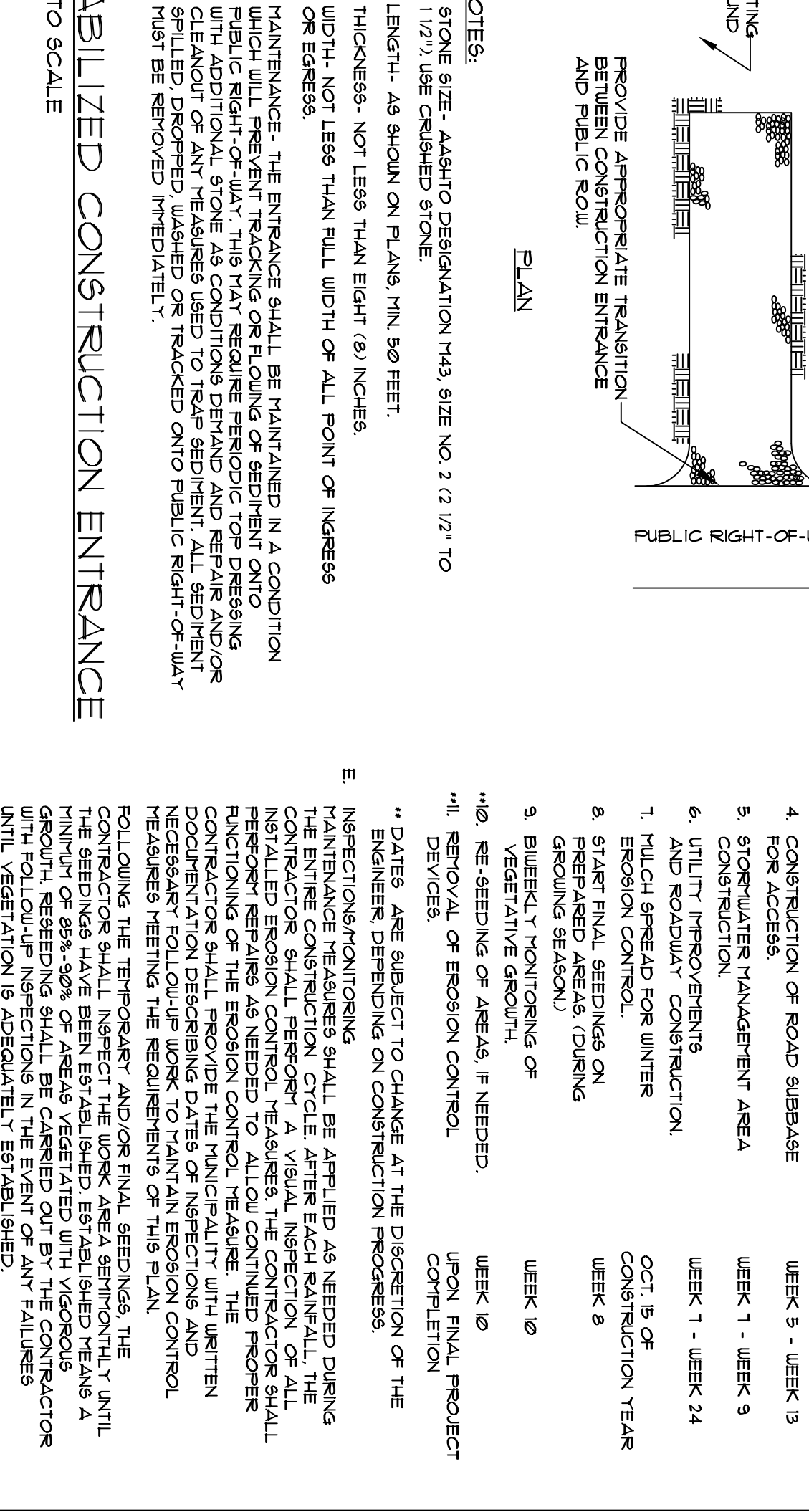

**VERTICAL GRANITE CURB / ENTRANCE SECTION**  
NOT TO SCALE

**Sebago Technics**  
Engineering Expertise You Can Build On  
One Chabot Street  
Westbrook, Me 04098-1339  
Tel (207) 856-0277

PROJECT NO. 02237  
FIELD BOOK 772  
DESIGN SMF  
CHKD SMF  
DRAWN ASB

DATE 6/17/06  
N.T.S.  
SHEET 5 OF 5

FOR: PATCO CONSTRUCTION, INC.  
1293 MAIN STREET  
SANFORD, ME 04073

THIS PLAN SHALL NOT BE MODIFIED WITHOUT WRITTEN PERMISSION FROM SEBAGO TECHNICS, INC. ANY ALTERATIONS, AUTHORIZED OR OTHERWISE, SHALL BE AT THE USER'S SOLE RISK AND WITHOUT LIABILITY TO SEBAGO TECHNICS, INC.