

DISPLAY THIS CARD ON PRINCIPAL FRONTAGE OF WORK

CITY OF PORTLAND

BUILDING INSPECTION

PERMIT

Please Read Application And Notes, If Any, Attached

PERMIT ISSUED

Permit Number: 070533
MAY 30 2007

CITY OF PORTLAND

This is to certify that J & H PROPERTIES LLC

has permission to 12.5 Freestanding sign

AT 340 PRESUMPCOT ST

422 B058001

provided that the person or persons, firm or corporation accepting this permit shall comply with all of the provisions of the Statutes of Maine and of the Ordinances of the City of Portland regulating the construction, maintenance and use of buildings and structures, and of the application on file in this department.

Apply to Public Works for street line and grade if nature of work requires such information.

Notification of inspection must be given and when permission procured before this building or part thereof is placed or closed-in. **24 HOUR NOTICE IS REQUIRED.**

A certificate of occupancy must be procured by owner before this building or part thereof is occupied.

OTHER REQUIRED APPROVALS

Fire Dept. _____

Health Dept. _____

Appeal Board _____

Other _____

Department Name

5/25/07 *Chety S.M.*
Director - Building & Inspection Services

PENALTY FOR REMOVING THIS CARD



CITY OF PORTLAND, MAINE
Department of Building Inspection

Certificate of Occupancy

LOCATION 352 PRESUMPSCOT ST

CBL 422 B058001

Issued to J & H PROPERTIES LLC /Patco Construction

Date of Issue 10/26/2007

This is to certify that the building, premises, or part thereof, at the above location, built — altered — changed as to use under Building Permit No. 06-0846 , has had final inspection, has been found to conform substantially to requirements of Zoning Ordinance and Building Code of the City, and is hereby approved for occupancy or use, limited or otherwise, as indicated below.

PORTION OF BUILDING OR PREMISES

Entire

APPROVED OCCUPANCY

Office/Warehouse
Use group S/B Type 2B
IBC 2003

Limiting Conditions:

This certificate supersedes
certificate issued

Approved:

10/26/07

(Date)

Inspector

Inspector of Buildings

Notice: This certificate identifies lawful use of building or premises, and ought to be transferred from owner to owner when property changes hands. Copy will be furnished to owner or lessee for one dollar.

City of Portland, Maine - Building or Use Permit Application

389 Congress Street, 04101 Tel: (207) 874-8703, Fax: (207) 874-8716

| | | |
|-----------------------|-------------|---------------------|
| Permit No: 07-0533 | Issue Date: | CBL: 422 B058001 |
|-----------------------|-------------|---------------------|

| | | | |
|--|-------------------------------------|-----------------------------------|-------------|
| Location of Construction: 340 PRESUMPCOT ST | Owner Name: J & H PROPERTIES LLC | Owner Address: 56 MAIN ST | Phone: |
| Business Name: | Contractor Name: | Contractor Address: | Phone: |
| Lessee/Buyer's Name | Phone: | Permit Type: Signs - Permanent | Zone: IL |

| | | | | |
|---|--|---|--|--------------------|
| Past Use: Commercial / Pack Edge | Proposed Use: Commercial / Pack Edge 12.5 freestanding sign | Permit Fee: \$55.00 | Cost of Work: \$55.00 | CEO District: 4 |
| Proposed Project Description: 12.5 Freestanding sign | | FIRE DEPT: <input type="checkbox"/> Approved <input type="checkbox"/> Denied | INSPECTION: Use Group: <i>Signs</i> Type: <i>OS</i> <i>ABE-2003</i> Signature: <i>[Signature]</i> | |
| | | PEDESTRIAN ACTIVITIES DISTRICT (P.A.D.) Action: <input type="checkbox"/> Approved <input type="checkbox"/> Approved w/Conditions <input type="checkbox"/> Denied Signature: _____ Date: _____ | | |

| | | |
|-----------------------------|---------------------------------|------------------------|
| Permit Taken By: dmartin | Date Applied For: 05/11/2007 | Zoning Approval |
|-----------------------------|---------------------------------|------------------------|

- This permit application does not preclude the Applicant(s) from meeting applicable State and Federal Rules.
- Building permits do not include plumbing, septic or electrical work.
- Building permits are void if work is not started within six (6) months of the date of issuance. False information may invalidate a building permit and stop all work..

| Special Zone or Reviews | Zoning Appeal | Historic Preservation |
|---|--|---|
| <input type="checkbox"/> Shoreland | <input type="checkbox"/> Variance | <input checked="" type="checkbox"/> Not in District or Landmark |
| <input type="checkbox"/> Wetland | <input type="checkbox"/> Miscellaneous | <input type="checkbox"/> Does Not Require Review |
| <input type="checkbox"/> Flood Zone | <input type="checkbox"/> Conditional Use | <input type="checkbox"/> Requires Review |
| <input type="checkbox"/> Subdivision | <input type="checkbox"/> Interpretation | <input type="checkbox"/> Approved |
| <input type="checkbox"/> Site Plan | <input type="checkbox"/> Approved | <input type="checkbox"/> Approved w/Conditions |
| Maj <input type="checkbox"/> Minor <input type="checkbox"/> MM <input type="checkbox"/> | <input type="checkbox"/> Denied | <input type="checkbox"/> Denied |
| Date: <i>OK</i> <i>5/25/07</i> <i>ABM</i> | Date: _____ | Date: <i>ABM</i> |

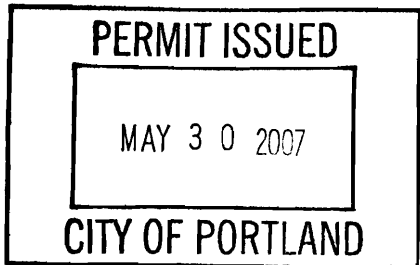

CERTIFICATION

I hereby certify that I am the owner of record of the named property, or that the proposed work is authorized by the owner of record and that I have been authorized by the owner to make this application as his authorized agent and I agree to conform to all applicable laws of this jurisdiction. In addition, if a permit for work described in the application is issued, I certify that the code official's authorized representative shall have the authority to enter all areas covered by such permit at any reasonable hour to enforce the provision of the code(s) applicable to such permit.

| | | | |
|---|---------|------|-------|
| SIGNATURE OF APPLICANT | ADDRESS | DATE | PHONE |
| RESPONSIBLE PERSON IN CHARGE OF WORK, TITLE | | DATE | PHONE |

City of Portland, Maine - Building or Use Permit

389 Congress Street, 04101 Tel: (207) 874-8703, Fax: (207) 874-8716

| | | |
|------------------------------|--|----------------------------|
| Permit No: 07-0533 | Date Applied For: 05/11/2007 | CBL: 422 B058001 |
|------------------------------|--|----------------------------|

| | | | |
|---|--|--|---------------|
| Location of Construction: 340 PRESUMPCOT ST | Owner Name: J & H PROPERTIES LLC | Owner Address: 56 MAIN ST | Phone: |
| Business Name: | Contractor Name: | Contractor Address: | Phone: |
| Lessee/Buyer's Name | Phone: | Permit Type: Signs - Permanent | |

| | |
|---|--|
| Proposed Use: Commercial / Pack Edge 12.5 freestanding sign | Proposed Project Description: 12.5 Freestanding sign |
|---|--|

Dept: Zoning **Status:** Approved **Reviewer:** Ann Machado **Approval Date:** 05/24/2007
Note: **Ok to Issue:**

Dept: Building **Status:** Approved with Conditions **Reviewer:** Chris Hanson **Approval Date:** 05/25/2007
Note: **Ok to Issue:**

- 1) Fastener schedule per the IRC 2003
- 2) Signage Installation to comply with Chapter 31 of the IBC 2003 building code.



Signage/Awning Permit Application

If you or the property owner owes real estate or personal property taxes or user charges on any property within the City, payment arrangements must be made before permits of any kind are accepted.

| | | |
|--|---|---|
| Location/Address of Construction: <u>340 Presumpscot St</u> | | |
| Tax Assessor's Chart, Block & Lot Chart# <u>422</u> Block# <u>B</u> Lot# <u>58</u> | Owner: <u>J+H Properties</u> | Telephone: <u>207 838-8075</u> |
| Lessee/Buyer's Name (If Applicable) | Contractor name, address & telephone: <u>SKAW IS 12.5 FT 12.5</u> <u>Jim Feenun</u> <u>Dawna Hall</u> | Total s.f. of signage x \$2.00 Per s.f. plus \$30.00/\$65.00 <u>125 SF</u> For H.D. signage= Total Fee: \$ <u>56</u> Awning Fee= cost of work _____ Total Fee: \$ <u>56⁰⁰</u> |
| Who should we contact when the permit is ready: <u>838-8075</u> phone: <u>879-7700</u> | | |
| Tenant/allocated building space frontage (feet): Length: <u>140'</u> Height: <u>24'</u> Lot Frontage (feet) <u>233</u> Single Tenant or Multi Tenant Lot <u>Simple</u> | | |
| Current Specific use: <u>Ware house</u> If vacant, what was prior use: _____ Proposed Use: _____ | | |
| Information on proposed sign(s): Freestanding (e.g., pole) sign? Yes <input checked="" type="checkbox"/> No _____ Dimensions proposed: _____ Height from grade: <u>5'</u> Bldg. wall sign? (attached to bldg) Yes _____ No _____ Dimensions proposed: _____ | | |
| Proposed awning? Yes _____ No <input checked="" type="checkbox"/> Is awning backlit? Yes _____ No _____ Height of awning: _____ Length of awning: _____ Depth: _____ Is there any communication, message, trademark or symbol on it? Yes _____ No _____ If yes, total s.f. of panels w/communications, message, trademark or symbol: _____ s.f. | | |
| Information on existing and previously permitted sign(s): Freestanding (e.g., pole) sign? Yes _____ No _____ Dimensions: _____ Bldg. wall sign? (attached to bldg) Yes _____ No _____ Dimensions: _____ Awning? Yes _____ No _____ Sq. ft. area of awning w/communication: _____ | | |
| <div style="border: 1px solid black; padding: 5px; display: inline-block;"> DEPT. OF BUILDING INSPECTION CITY OF PORTLAND, ME MAY 11 2007 RECEIVED </div> | | |
| A site sketch and building sketch showing exactly where existing and new signage is located must be provided. Sketches and/or pictures of proposed signage and existing building are also required. | | |

Please submit all of the information outlined in the Sign/Awning Application Checklist. Failure to do so may result in the automatic denial of your permit.

In order to be sure the City fully understands the full scope of the project, the Planning and Development Department may request additional information prior to the issuance of a permit. For further information visit us on-line at www.portlandmaine.gov, stop by the Building Inspections office, room 315 City Hall or call 874-8703.

I hereby certify that I am the Owner of record of the named property, or that the owner of record authorizes the proposed work and that I have been authorized by the owner to make this application as his/her authorized agent. I agree to conform to all applicable laws of this jurisdiction. In addition, if a permit for work described in this application is issued, I certify that the Code Official's authorized representative shall have the authority to enter all areas covered by this permit at any reasonable hour to enforce the provisions of the codes applicable to this permit.

Signature of applicant: _____ Date: 5/9/07

This is not a permit; you may not commence ANY work until the permit is issued.

max sign. hgt. - 35ft
height max 10'
set back 5-
one allowed

at

Proposed 125 sq ft
10 sign 5' sign
#10211

Presumpscot St

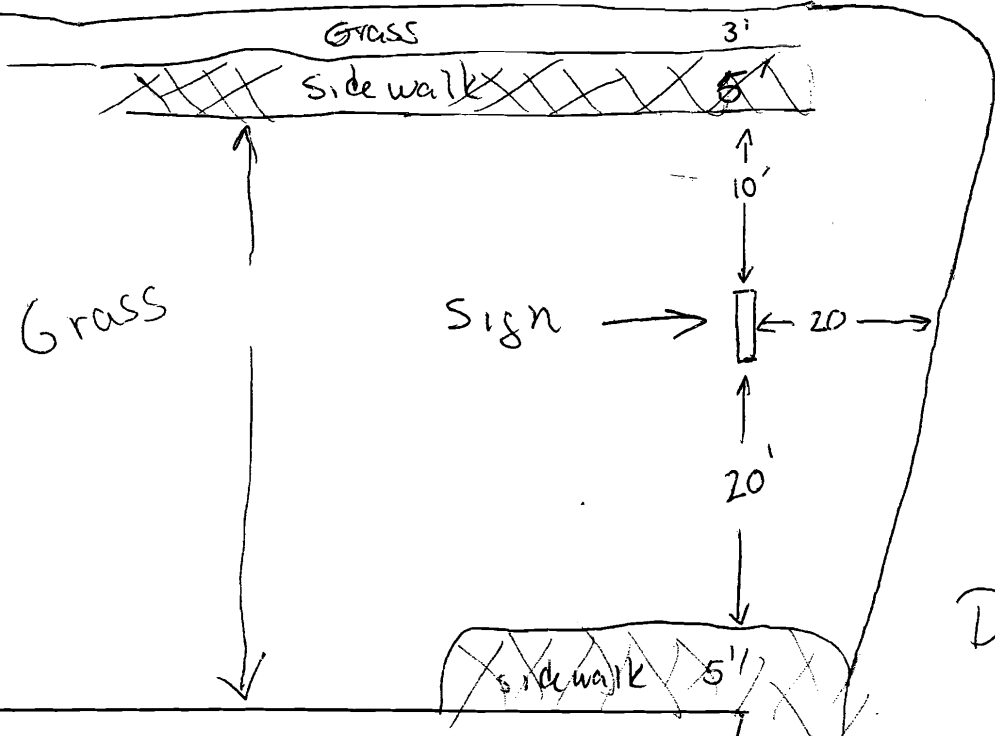

Grass

Grass

sidewalk

3'

10'

Sign

20

20'

Driveway

sidewalk

5'

PAVE EDGE

The SIGNERY
 MAINE'S MOST COMPLETE SIGNAGE RESOURCE

84 COVE STREET PORTLAND, ME
 PHONE 879-7700 FAX 879-1570

INVOICE #
 est 3801

INSTALL
 YES

DESIGNER
 DH

V
 B



PROOFS SENT **DESIGN**

| | |
|--|--|
| | |
| | |
| | |
| | |
| | |
| | |
| | |
| | |

FONTS

PLEASE READ CAREFULLY

This proof may reflect color shifts due to the color conversions from ink to paint and or vinyl. Also PMS colors will be approximated to the best of our ability. If we are supplied with files (if applicable) they will be used as is and the Signery will not be responsible for any faults in the design (300 dpi required).

PLEASE REVIEW THE FOLLOWING CHECK LIST:

- Spelling
- Quantity
- Graphics / Logos
- Size
- Fonts / Typeface
- Single / Double Sided
- Colors
- Legibility

BY SIGNING OFF ON THIS PROOF YOU ARE GIVING THE SIGNERY THE GO TO PRODUCE THIS WORK TO THE SPECIFICATIONS LISTED UNTIL THIS JOB IS APPROVED AND A DEPOSIT IS MADE, THIS PROOF IS THE PROPERTY OF THE SIGNERY



(2) 3/4" MDO OVALS w/5" SPACERS
 COVERED WITH .040 ALUMINUM
 30" x 60"
 TO MOUNT TO 24" x 48" BASE
 TWO 4x4's SURROUNDED BY 3/4" MDO

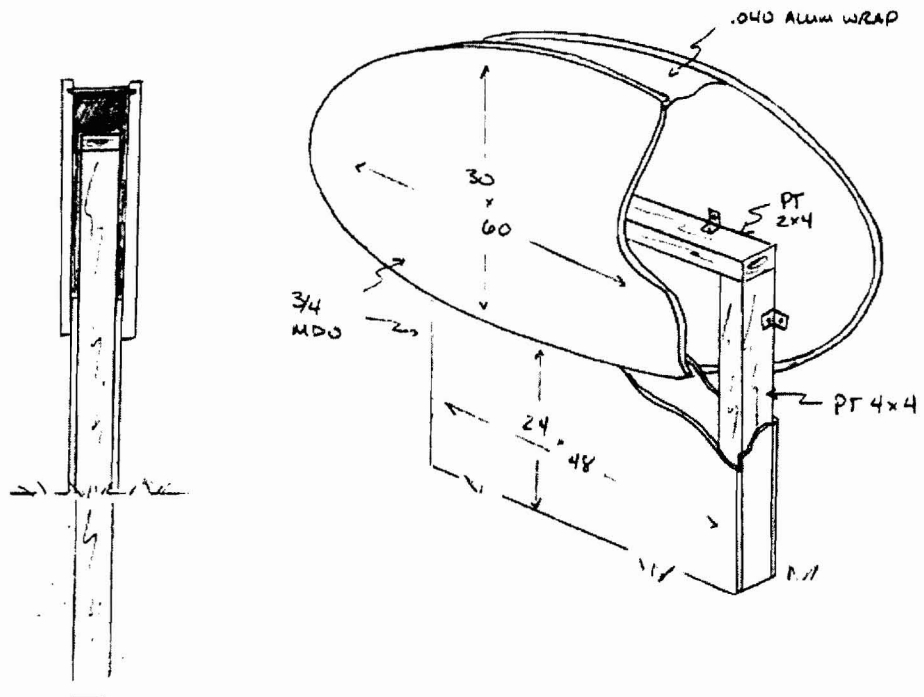

Approved by: _____

Date: _____

FILE FINDER: 2007-04

J&H Properties, LLC

**56 Main Street
Bowdoinham, ME 04008**

May 9, 2007

To Whom It May Concern:

I authorize Pack Edge Inc, located at 340 Presumpscot Street, Portland, ME 04103 to install a free standing sign in front of the building.

Sincerely,

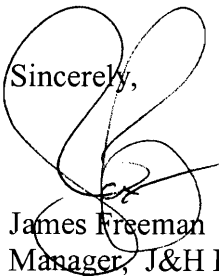
A handwritten signature in black ink, appearing to read 'James Freeman', is written over the printed name and title. The signature is stylized and somewhat cursive.

James Freeman
Manager, J&H Properties

Estimate



The Signery
 7 Lincoln Avenue
 Scarborough, ME 04074
 ph. 207-879-7700
 fax 207-510-0043
 email: signery@signerymaine.com

Estimate: 07- 3801

Printed 4/11/2007 3:44:16PM

Description: **Monument roadside sign**

Prepared For: Julieanne Zidow

Company: Pack Edge

ph: (207) 799-6600

fax: (207) 799-6626

email: jzpack@maine.rr.com

Dear Julieanne:

Thank you for considering The Signery for your sign needs. The quotation we discussed is attached below. If you have any questions, please don't hesitate to call me at 207-879.7700.

Sincerely

Dawna Hall

| Product | Font | Qty | Sides | Height | Width | Unit Cost | Item Total |
|-----------------------|------|-----|-------|--------|-------|-----------|------------|
| 1 MDO, 3/4" x 4' x 8' | | 3 | 1 | 48 | 96 | \$875.17 | \$2,625.51 |

Color:

Description: DIMENSIONAL MONUMENT SIGN

Medium Density Overlay (MDO), 3/4" x 4' x 8'. West System Edge Sealer, Two Coats of Primer, and Two Coats of One Color Finish.

Text:

| | | | | | | | |
|-----------------------|--|---|---|----|----|------------|------------|
| 2 MDO, 3/4" x 4' x 8' | | 1 | 2 | 48 | 96 | \$1,192.49 | \$1,192.49 |
|-----------------------|--|---|---|----|----|------------|------------|

Color: Black & Blue on White

Description: OVAL SIGN BETWEEN POSTS

Medium Density Overlay (MDO), 3/4" x 4' x 8'. West System Edge Sealer, Two Coats of Primer, and Two Coats of One Color Finish.

Text:

Notes:

| | |
|------------------|-------------------|
| Line Item Total: | \$3,818.00 |
| Subtotal: | \$3,818.00 |
| Taxes: | \$190.90 |
| Total: | \$4,008.90 |

Deposit Required : \$2,004.45

Company: Pack Edge
 Presumpscot St
 Portland, ME 04103

Received/Accepted By: _____

/ /

Please call 874-8703 or 874-8693 to schedule your inspections as agreed upon

Permits expire in 6 months, if the project is not started or ceases for 6 months.

The Owner or their designee is required to notify the inspections office for the following inspections and provide adequate notice. Notice must be called in 48-72 hours in advance in order to schedule an inspection:

By initializing at each inspection time, you are agreeing that you understand the inspection procedure and additional fees from a "Stop Work Order" and "Stop Work Order Release" will be incurred if the procedure is not followed as stated below.

A Pre-construction Meeting will take place upon receipt of your building permit.

- | | | |
|-------------------------------------|---------------------------------------|--|
| <input type="checkbox"/> | Footing/Building Location Inspection: | Prior to pouring concrete |
| <input type="checkbox"/> | Re-Bar Schedule Inspection: | Prior to pouring concrete |
| <input checked="" type="checkbox"/> | Foundation Inspection: | Prior to placing ANY backfill |
| <input type="checkbox"/> | Framing/Rough Plumbing/Electrical: | Prior to any insulating or drywalling |
| <input checked="" type="checkbox"/> | Final Certificate of Occupancy: | Prior to any occupancy of the structure or use. NOTE: There is a \$75.00 fee per inspection at this point. |

Certificate of Occupancy is not required for certain projects. Your inspector can advise you if your project requires a Certificate of Occupancy. All projects DO require a final inspection

If any of the inspections do not occur, the project cannot go on to the next phase, REGARDLESS OF THE NOTICE OR CIRCUMSTANCES.

CERTIFICATE OF OCCUPANCIES MUST BE ISSUED AND PAID FOR, BEFORE THE SPACE MAY BE OCCUPIED

Signature of Applicant/Designee

Doree Martin Admin

Signature of Inspections Official

Date

5-30-07

Date

CBL: 422 B 058

Building Permit #: 07-0533

Please call 874-8703 or 874-8693 to schedule your inspections as agreed upon

Permits expire in 6 months, if the project is not started or ceases for 6 months.

The Owner or their designee is required to notify the inspections office for the following inspections and provide adequate notice. Notice must be called in 48-72 hours in advance in order to schedule an inspection:

By initializing at each inspection time, you are agreeing that you understand the inspection procedure and additional fees from a "Stop Work Order" and "Stop Work Order Release" will be incurred if the procedure is not followed as stated below.

A Pre-construction Meeting will take place upon receipt of your building permit.

- Footing/Building Location Inspection: Prior to pouring concrete
- Re-Bar Schedule Inspection: Prior to pouring concrete
- Foundation Inspection: Prior to placing ANY backfill
- Framing/Rough Plumbing/Electrical: Prior to any insulating or drywalling
- Final/Certificate of Occupancy: Prior to any occupancy of the structure or use. NOTE: There is a \$75.00 fee per inspection at this point.

Certificate of Occupancy is not required for certain projects. Your inspector can advise you if your project requires a Certificate of Occupancy. All projects DO require a final inspection

If any of the inspections do not occur, the project cannot go on to the next phase, REGARDLESS OF THE NOTICE OR CIRCUMSTANCES.

CERTIFICATE OF OCCUPANCIES MUST BE ISSUED AND PAID FOR, BEFORE THE SPACE MAY BE OCCUPIED

[Signature]
Signature of Applicant/Designee

5-30-07
Date

[Signature]
Signature of Inspections Official

5-30-07
Date

CBL: 34AC1

Building Permit #: 070414