

ISSUED FOR CONSTRUCTION

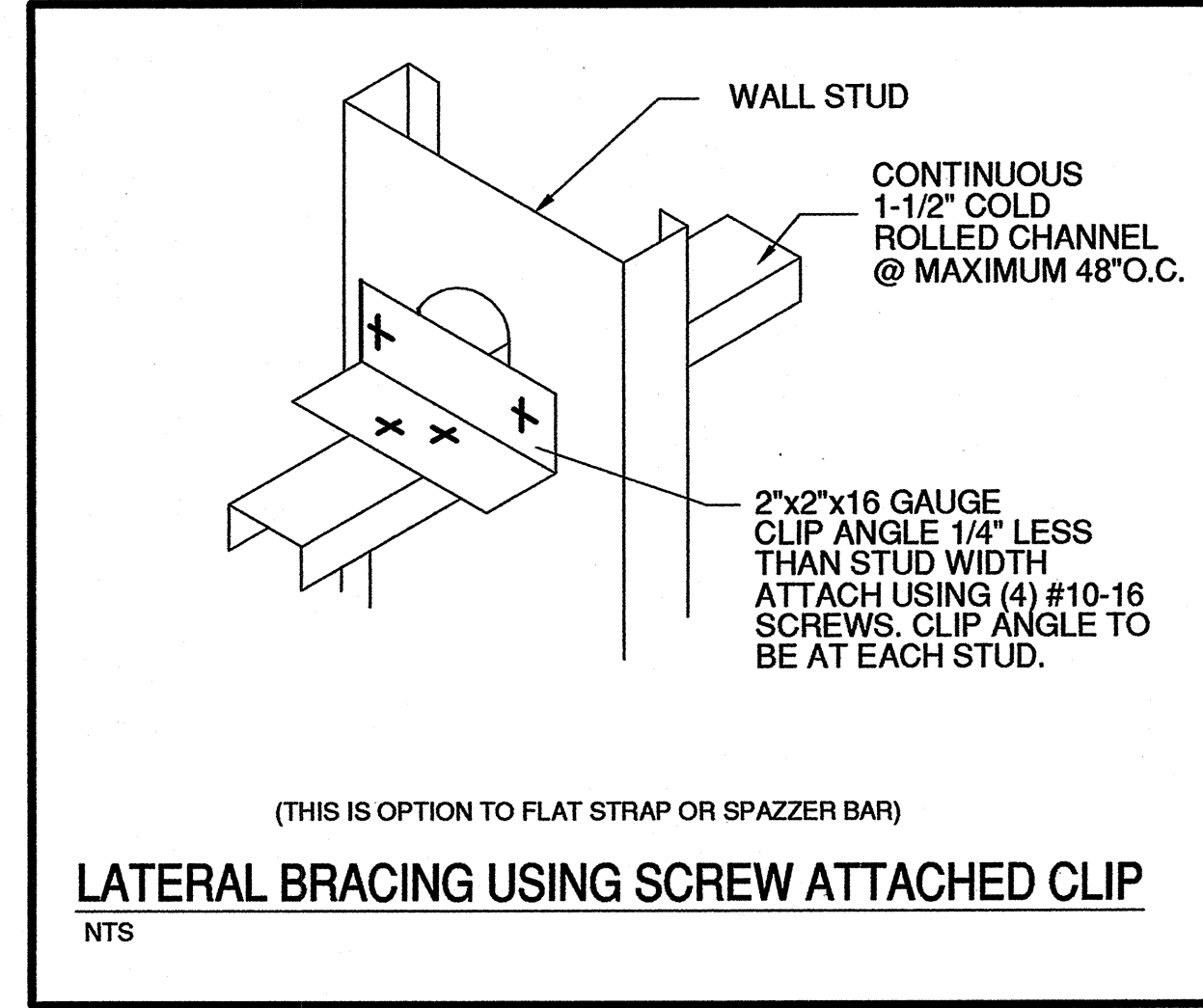
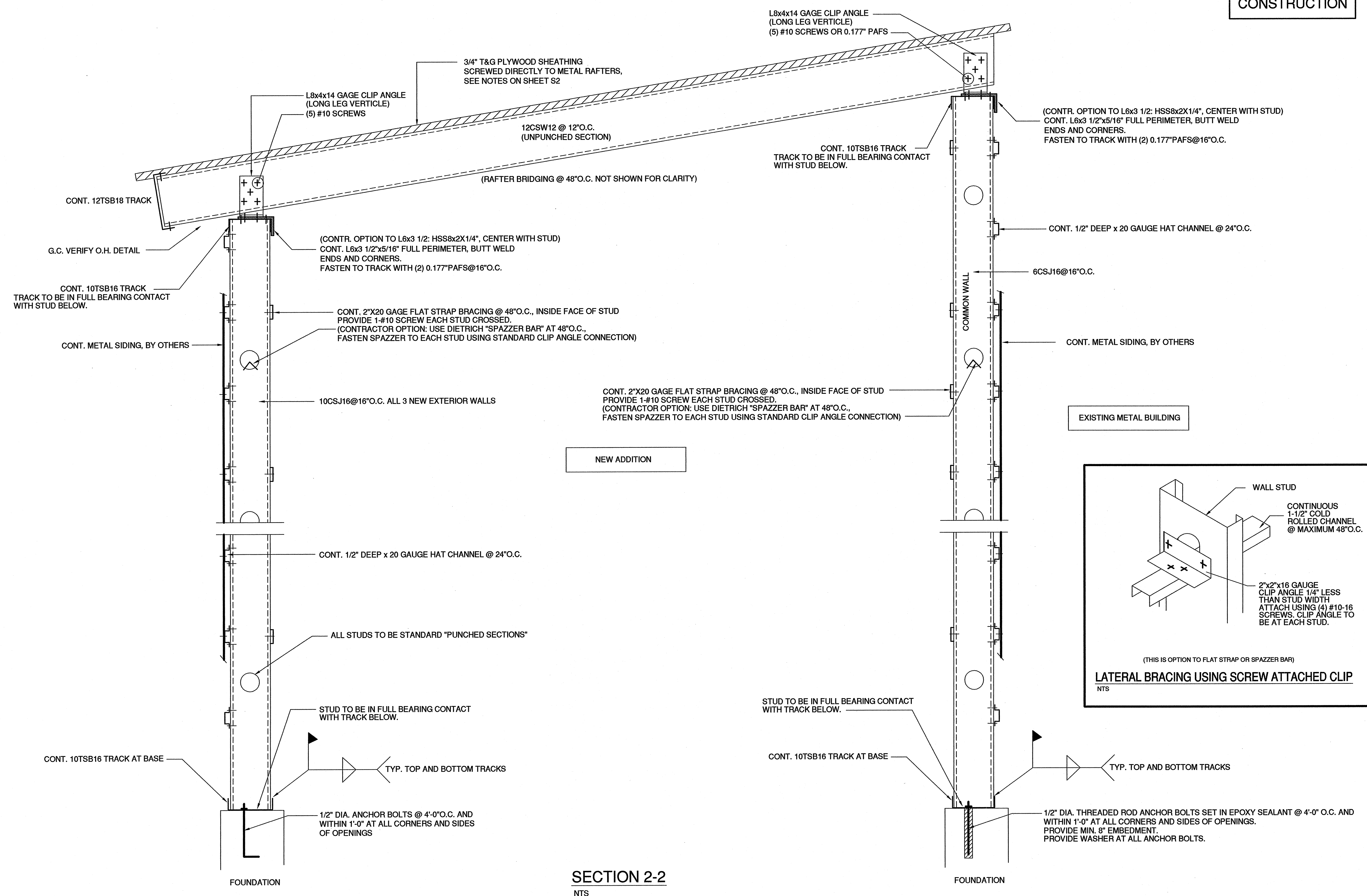
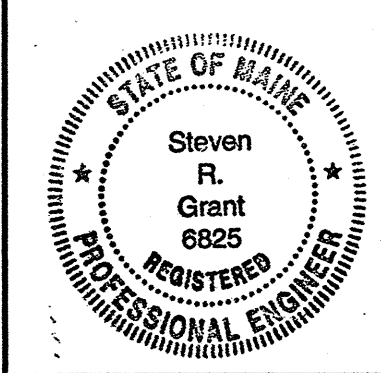

REV.	BY	DATE	STATUS

THIS PLAN SHALL NOT BE AMENDED WITHOUT WRITTEN PERMISSION FROM SRG ENGINEERING, INC. ANY ALTERATIONS AUTHORIZED OR OTHERWISE, SHALL BE AT THE USER'S SOLE RISK AND WITHOUT LIABILITY TO SRG ENGINEERING, INC.

PROJECT NO.	04-087
DATE	06-22-04
DESIGN	SRG
CHKD	SRG
DRAWN	SRG

SRG ENGINEERING, INC.
CONSULTING STRUCTURAL ENGINEERS
P.O. BOX 925
GRAY, ME 04039
TEL: (207) 657-7323
FAX: (207) 657-7342
EMAIL: SRG@SRGENG.COM

ROOF FRAMING PLAN AND DETAILS
OF
SIGCO GLASS ADDITION
FOR
HARDYOND CONSTRUCTION
PORTLAND, MAINE

DATE	SCALE
06-22-04	NONE

SHEET S3