

TYPICAL RAFTER TRIM DETAIL

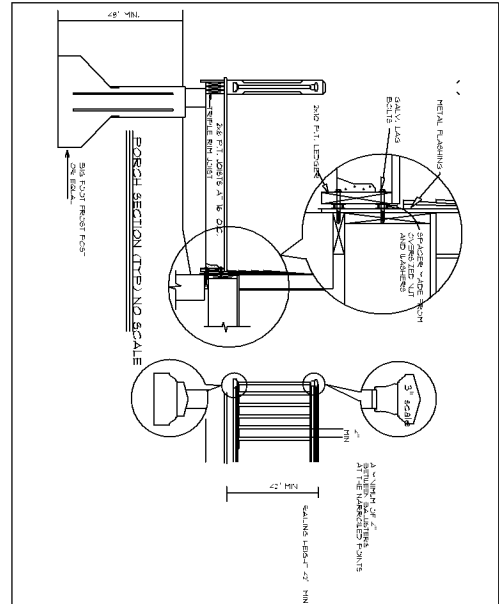
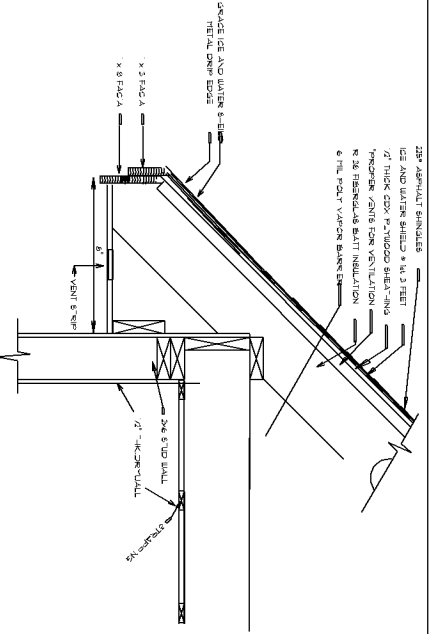

FORCED HOT WATER OIL HEAT

SECTION / MATERIAL	DESCRIPTION / DETAILS	U-FACTOR / R-VALUE	COMMENTS
ROOF	2x4 Rafter, 1/2" Ply, 1/2" Drywall, 1/2" Insulation	0.035	
WALL	2x6 Stud, 1/2" Ply, 1/2" Drywall, 1/2" Insulation	0.075	
FLOOR	2x6 Joist, 1/2" Ply, 1/2" Drywall, 1/2" Insulation	0.055	
FOUNDATION	8" Concrete, 4" Insulation	0.025	
STAIR	2x6 Tread, 2x6 Riser, 1/2" Ply	0.045	
SCREENING	3/4" Ply, 1/2" Drywall, 1/2" Insulation	0.020	

FASTENING SCHEDULE (SEE TABLE 2304.9.1 ME & RESIDENTIAL CONSTRUCTION CODE FOR COMPLETE DETAILS)

GENERAL NOTES:
 1. ALL MATERIALS TO BE INSTALLED IN ACCORDANCE WITH THE MANUFACTURER'S INSTRUCTIONS.
 2. ALL FASTENERS TO BE INSTALLED IN ACCORDANCE WITH THE MANUFACTURER'S INSTRUCTIONS.
 3. ALL JOINTS TO BE MADE IN ACCORDANCE WITH THE MANUFACTURER'S INSTRUCTIONS.
 4. ALL MATERIALS TO BE INSTALLED IN ACCORDANCE WITH THE MANUFACTURER'S INSTRUCTIONS.

NOTE: ALL WINDOWS U-FACTOR = .31

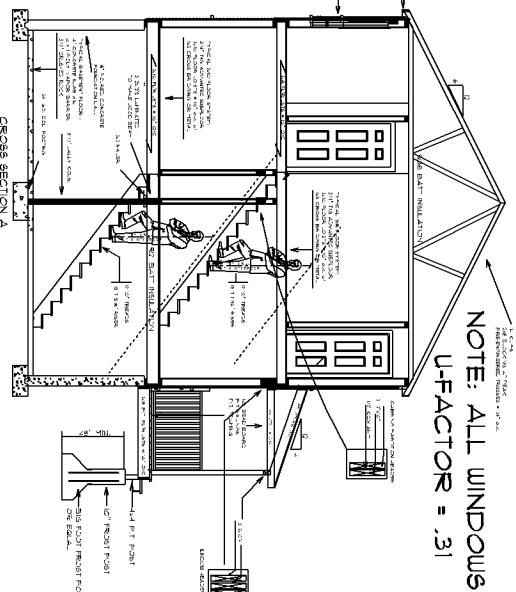

TYPICAL FOUNDATION WALL SECTION - MAIN HOUSE

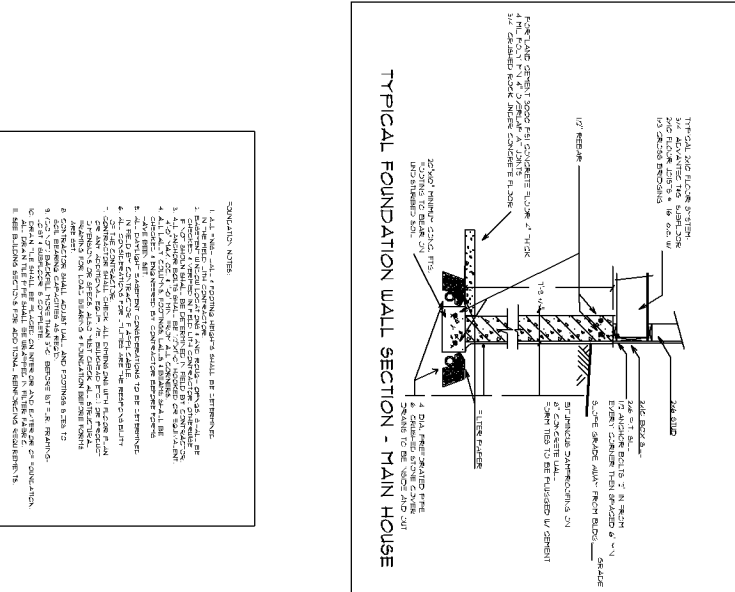

THESE PLANS ARE TO BE CONSIDERED ONLY AS GENERAL GUIDES AND NOT BE USED AS A SUBSTITUTE FOR THE ARCHITECT'S SPECIFICATIONS. THE CONTRACTOR SHALL BE RESPONSIBLE FOR VERIFYING ALL DIMENSIONS AND CONDITIONS PRIOR TO CONSTRUCTION. THE CONTRACTOR SHALL BE RESPONSIBLE FOR OBTAINING ALL NECESSARY PERMITS AND FOR COMPLIANCE WITH ALL APPLICABLE CODES AND REGULATIONS.

PROJECT NAME:

PRESUMPCOT SPEC

CONTRACTOR:

KIRKWOOD LLC.

DATE:	Feb 14, 2025
DRAWN:	EA-S/STP
TITLE:	Presumpcot