

FIRST FLOOR
 HOUSE: 1,726 S.F. 1/4" = 1'-0"
 GARAGE: 550 S.F.

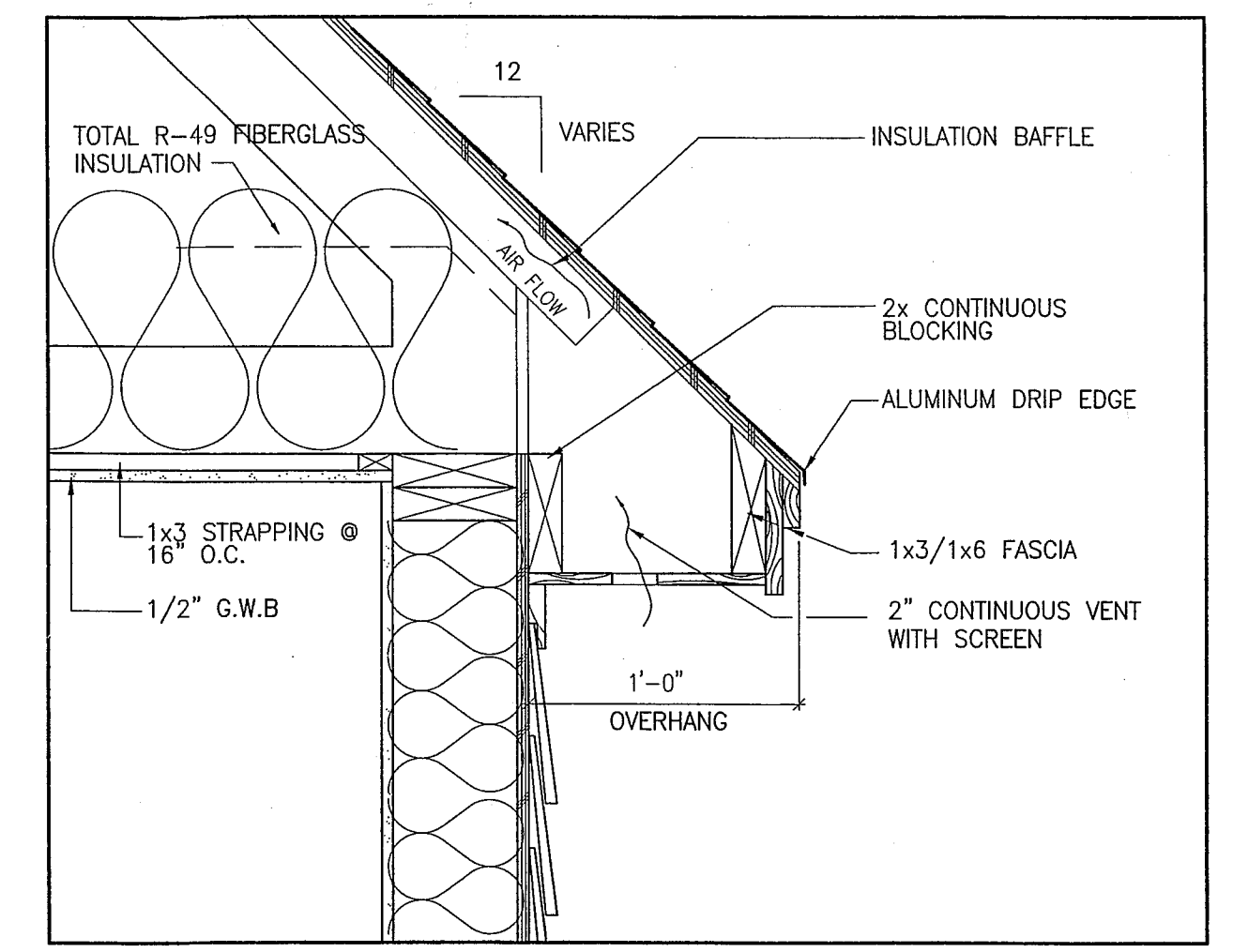

① **EAVE DETAIL** SCALE: 1 1/2" = 1'-0"

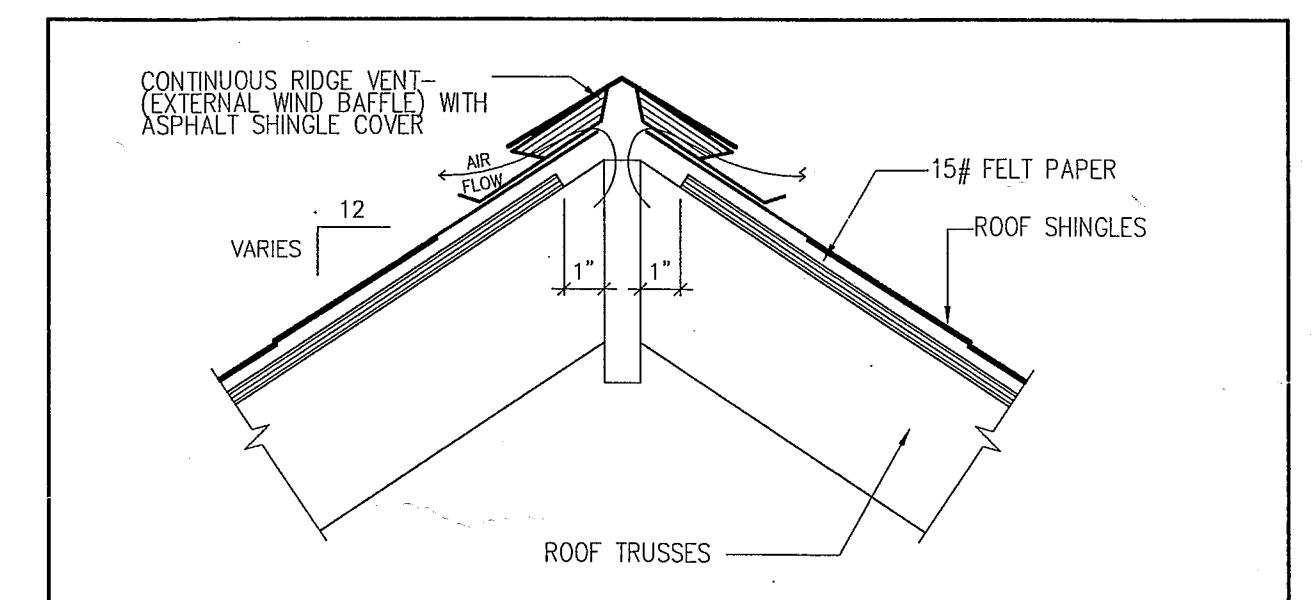

② **RIDGE VENT DETAIL** SCALE: 1 1/2" = 1'-0"

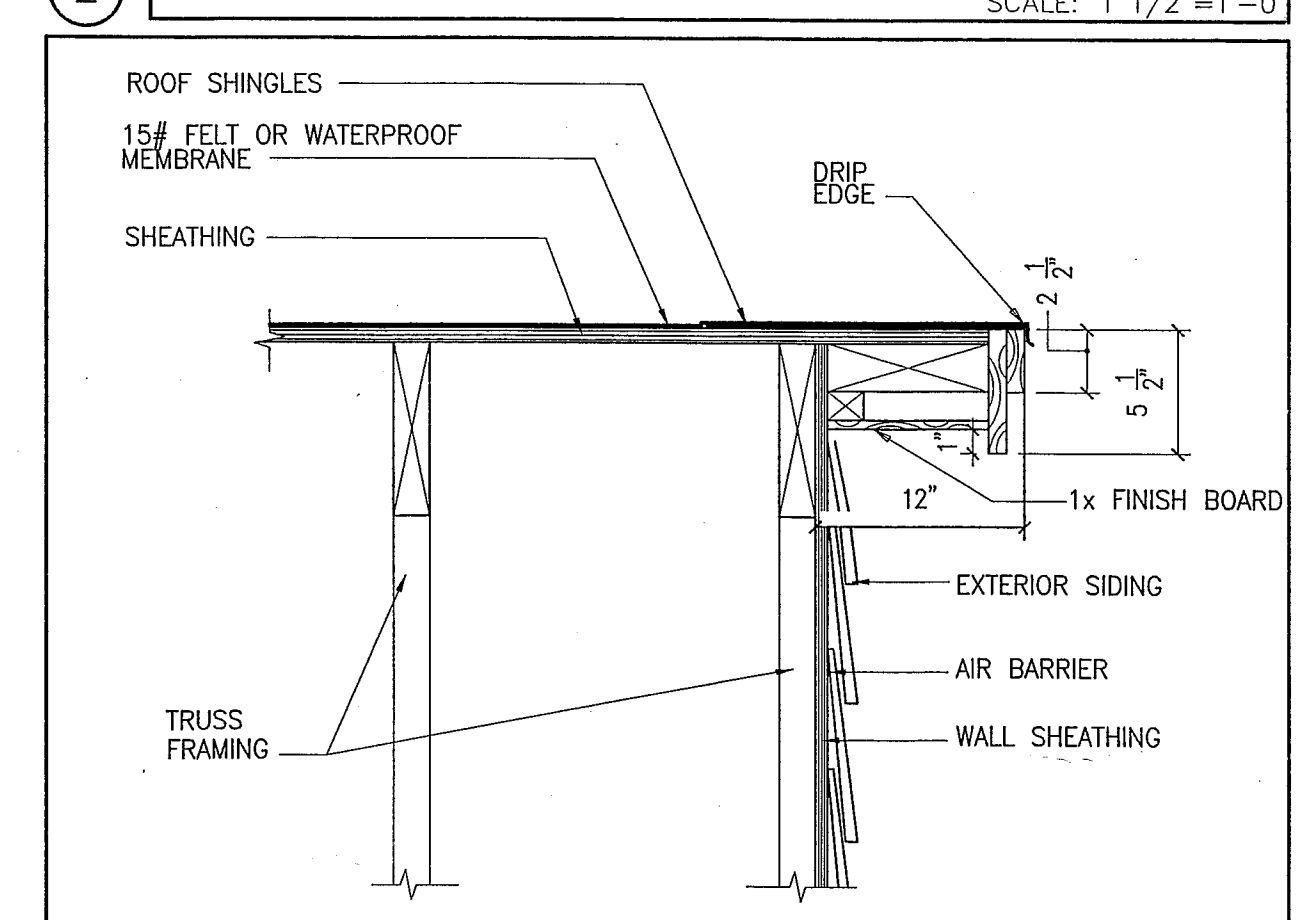

③ **RAKE DETAIL** SCALE: 1 1/2" = 1'-0"

45 ICE POND ROAD
 PORTLAND, MAINE

DRAWINGS THIS SHEET
 FIRST FLOOR PLAN
 DETAILS

11/02/14

A1