

Fire Alarm Submittal for:
Portland Retirement Residence
802 Ocean Avenue
Portland ME 04103

System Designer:

Christopher Mendel, SET
NICET # 96065 (Exp.03.01.19)
FPET – Fire Alarm Systems Level IV



Installation Firm:

Birchall Electric
142 Main St Unit B
Salem NH 03079
Maine License MS6002111

A New Fire Alarm System for:
Portland Retirement Residence
802 Ocean Avenue
Portland ME 04103

System/Installation Narrative:

This Fire Alarm System will be installed in a new residential apartment complex. It is an I-1, A-2, A-3 and B Occupancy type. The design is based on a prescriptive design. There will be a voice evacuation system in the A occupancy portion of Atrium per Code. The building is fully sprinklered per NFPA 13. The U.L.listed, addressable, manual and automatic fire alarm system will meet the requirements of Portland ME and the Maine State Fire Marshal's Office adopted Building and Fire codes, including all published, adopted amendments. Installation standards will adhere to **NFPA72, 2010** edition. The installation will be conducted by a State Licensed Alarm Contractor.

System Designer:

Christopher Mendel, SET
NICET # 96065 (Exp.03.01.19)
FPET – Fire Alarm Systems Level IV



➤ The Fire Alarm System will consist of:

- Sprinkler Water Flow, Tamper Switch, Pressure switch and Fire pump monitoring.
- Means of manual activation from a Manual Pull Station located at each exit
- Remote annunciator at front entry.
- Automatic Heat and smoke detection.
- Low Frequency Horns in each sleeping room and ADA Low Frequency horn/strobes and strobes in ADA H.C rooms.
- Horn/Strobes in corridor and public common areas.
- Voice evacuation in atrium per IFC 907.2.14
- Weatherproof Horn/Strobe above the FDC located outside of riser room.
- Relays for Closing of Fire/Smoke dampers as required.
- Elevator Recall and Elevator Smoke Vent control.
- Door Holder Release.
- Atrium Smoke evacuation system
- Kitchen Hood Suppression system Monitoring, Installed by others
- Monitoring of All 120V smoke detectors, Detectors installed by others

- The Fire Alarm System, **indicating (NAC) circuits, shall be Class ‘B’ wired and the initiating (SLC) circuit shall be Class ‘B’ wired. All wiring will be supervised.**
- All conduit, raceways and back boxes to be provided and installed. Fire Alarm contractor to coordinate all sizes, locations, etc., with the General Contractor, Sprinkler Contractor, Mechanical Contractor and Electrical Contractor prior to installation.
- The primary power source for the 120vac circuit for the Fire Alarm Panel Controls and Fire Alarm Power Supplies must be dedicated per **NFPA 72**.. The circuit must be identified at the control panel as well as the electrical panel. The disconnect means must be labeled, painted red and mechanically locked to prevent accidental disconnect per **NFPA 72**.
- The fire alarm system will be monitored by a U.L. Listed Central Station for Remote System Type monitoring. No Runner Service. Communications will be accomplished by (2) Means of communications for Primary and secondary per **NFPA 72**
- Smoke Detectors will be installed throughout the facility in all occupiable areas, excluding restrooms, closets and storage rooms which are covered by the fire sprinkler system. Thirty foot (**30’**) spacing calculations were used for all room smoke detectors per, **NFPA72**., Forty Two foot (**42’**) spacing calculations were used for hallways, per **NFPA72, A.** The utilization of the smoke detectors to accomplish door release will be in accordance with **NFPA 72**., The utilization of smoke detectors to accomplish smoke control for the atrium smoke evacuation will be in accordance with **NFPA 72**.
- Any required 110 Volt Room Smoke detectors will be installed by others and monitored by the Fire alarm system. Reference building permit set for exact location and quantity
- All RTU’s with a design capacity above 2000cfm, per **IMC**, will have Mechanical Contractor supplied, powered and installed conventional Duct Detector which will be monitored by the Fire Alarm System for trouble and alarm/supervisory conditions. RTU fan shutdown will be accomplished from the affected duct sensor activation. Remote Test Switches will be installed adjacent to the associated RTU/AHU.
- Tamper Switches and duct detectors for the Fire Alarm System will be programed as a supervisory. Water Flow, pressure Switches, Manual Pull Stations, Heat Detectors and the Smoke Detectors will activate all ADA compliant, **ADAAG, 4.28.1**, Speaker/Strobes and Strobes throughout the corresponding building. Additionally, any alarm from the Fire Sprinkler System will activate the exterior Horn/Strobe mounted above the FDC and will be non silenceable.
- Both Elevator recall for fire fighters service will be installed per **NFPA 72**. Primary recall, Alternate recall, and Fireman’s alert lamp will be accomplished per **NFPA 72** Elevator shutdown and monitoring of elevator power will be in accordance with **NFPA 72**., Elevator Recall will also comply with Section **2.27 of ANSI/ASME A17.11a/CSA B44a**, Safety Code for Elevators.
- Kitchen hood suppression system will be installed by others and monitored as required for signal initiation by the fire alarm system per **NFPA 72**.
- If required Fire pump will be installed by others, the fire pump will be monitored by the fire alarm system for Pump Running as an alarm signal, Phase reversal, AC loss of power, and tampers switches as supervisory signal. Monitoring will be in accordance with **NFPA 72**. **All above ground valves or PIVs that control water exclusively supplying a fire sprinkler system shall be electrically monitored**

- All Speaker/Strobe, Horn/Strobes and Strobe appliances will be synchronized and installed using **NFPA72**, for room spacing and **NFPA72**, for hall spacing as applicable. All Horns will be set to high volume levels and shall produce a synchronized temporal tone. Audible/Visual low frequency notification in sleeping areas for ADA HC rooms will be installed using **NFPA 72**, and Horn only notification low frequency in sleeping areas will be installed using **NFPA 72..**
- The Fire Alarm Control System will have backup power sources of two **12vdc**, batteries and the Fire Alarm Power Supplies will have backup power source of two **12vdc per battery calcs**, batteries wired in series per the battery calculations for 24vdc operation Per capable of meeting/exceeding the 24hr standby period followed by 15 minutes of alarm at maximum system load per **NFPA 72** The batteries shall be marked with month and year of manufacturing once installed per **NFPA 72**.
- Copies of Fire Marshal approved, stamped, signed drawings along with a complete user's manual will be left with the Site Manager for their reference and all future annual inspections. Site personnel will be provided training on proper use of the Fire Alarm System by the installation contractor.

Device Type and Quantity

- 1 – Mircom FX2000MNS, 12amp Addressable Control Panel
- 1—Mircom ALCN-792N,Dual SLC Expansion Card
- 1—Mircom ALCN-792D, Quad SLC Expansion Card
- 1—Mircom UDACT-300A, Digital Dialer
- 1—Mircom FDX-008, Fan Damper Module
- 9—Mircom INX-10A, 10amp Addressable Nac Power Boosters
- 1—Mircom RAXN-LCD, Remote Annunciator
- 39 – Mircom MS-710ADU, Dual Action pull station
- 176—Mircom 2251B, Addressable Photo Smoke Detector
- 15—Mircom 5251B, 135 Fixed Addressable Heat Detectors
- 54—Mircom MIX-M500M, Addressable Monitor Modules
- 25—Mircom MIX-M500R, Addressable Relay Module
- 2—Mircom QAA-5415-70, 4 Zone 15Watt Amplifier
- 1—Mircom QMP-5101N, Master Microphone Annunciator Module
- 1—Mircom QMP5101NV Microphone Control Verticle Mount
- 1—Mircom QAZT-5302DS, Addressable Zoned Firefighters Telephone Selector
- 32—DHF 24120, Door Holders
- 6—Mircom CO1224T, 24V Carbon Monoxide detectors
- 8—System Sensor MR101, Multi Voltage Relay
- 1—System Sensor P2WK, Wall Mounted, Weather Proof Horn/Strobe
- 16—System Sensor P2WH-LF, High Candela Horn/Strobe Low Frequency
- 42—System Sensor P2W, Wall Mounted Horn/Strobes
- 36—System Sensor SR, Wall Mounted Strobes
- 147—System Sensor H-LF, Low Frequency Horns
- 37—System sensor SPSW, Wall Mount Speaker/Strobe
- 1—System Sensor SPSWk, Wall Mount Weatherproof Speaker/Strobe
- 4—System Sensor SP, Speaker only



**NATIONAL INSTITUTE FOR CERTIFICATION
IN ENGINEERING TECHNOLOGIES®**

Providing Certification Programs Since 1961

BE IT KNOWN THAT

Christopher R. Mendel

IS HEREBY AWARDED CERTIFICATION AT

LEVEL IV

**IN FIRE PROTECTION ENGINEERING TECHNOLOGY
FIRE ALARM SYSTEMS**

**BASED UPON SUCCESSFUL DEMONSTRATION OF REQUISITE KNOWLEDGE,
EXPERIENCE AND WORK PERFORMANCE AS SET FORTH BY THIS INSTITUTE.**

Certification Valid through March 1, 2019

CERTIFICATION NUMBER 96065

CHAIRMAN OF THE NICET BOARD OF GOVERNORS

A DIVISION OF THE NATIONAL SOCIETY OF PROFESSIONAL ENGINEERS

INTELLIGENT FIRE ALARM AND AUDIO NETWORK SYSTEM



FleXNet™



BBX-FXMNSR

BBX-5014R

Description

Mircom's FleX-Net™ Series Network Fire Alarm Control Panels offer modular components to meet a wide variety of applications. Designed for peer-to-peer network communications, the FleX-Net Series allows for a maximum of 63 nodes, while providing reliability, flexibility and expandability.

The FleX-Net Series is based on the proven and reliable FX-2000 Series platform. It expands on the base design to provide a powerful system capable of providing network control, multi-channel voice evacuation and two-way fire fighter communications over a single pair of wires or fiber-optic cable. Each base panel consists of one intelligent signaling line circuit (SLC) capable of supporting 99 analog sensors and 99 addressable modules. In addition the base panel also consists of 4 Style Z/Y (Class A/B) Notification Appliance Circuits rated at 1.7 Amps each and a large back-lit alphanumeric LCD display.

The audio control provides a multi-channel distributed audio system that allows for efficient emergency paging, evacuation signaling and fire fighters' telephone communication. Each audio card cage supports a maximum of 4 QAA style amplifiers for a maximum of 180 watts per cabinet.

Mircom's FleX-Net Series provides a new level of expansion and flexibility by providing support for BACnet, Boolean logic, and real time 3D graphic monitoring and control. In addition the system supports three configuration files which allows for the system to be easily configured without taking the panels offline.

FleX-Net's modular design allows for site specific customization and the ability to meet local and national requirements.

Features

Fire Alarm Control

- One expandable to twenty nine Intelligent Signaling Line Circuits (SLC)
- Each SLC is capable of supporting 99 Analog Sensors and 99 Addressable Modules which can be wired in Style 6 or 7 (Class A) or Style 4 (Class B)
- Four Style Z/Y (Class A/B) Notification Appliance Circuits rated at 1.7 Amps each
- Supports both 80 character and 960 character back-lit LCD displays with user friendly menu
- Supported languages: English, French, Arabic* and Hebrew* (*960 character back-lit LCD display only)
- Correlatable Switch Inputs which allows for multi-functional outputs
- Four Alarm Queues with selector switches and LEDs for Alarm, Supervisory, Monitor and Trouble
- RS-232 output for remote system printer or CRT
- Two Event History Logs comprised of a 6000 Alarm History Log and a 6000 Event Log for all events
- Built-in BACnet support
- System can be configured without taking the panel offline
- Supports three configuration files (current, previous and next configuration) with "hot swap" support
- Real time 3D graphical monitoring and control using Mircom's Open Graphic Navigator™
- Supports Boolean logic functions
- Built-in Ethernet port
- Remote diagnostics via a built-in web server
- UL listed for Smoke Control (UUKL)

Audio Control

- Multi-channel operation
- Distributed audio
- 5 hard wire fire fighter telephone channels that can be expanded with intelligent fire phone modules
- 25 or 70 volt system
- Multiple amplifier sizes
- Max. of 180 watts per Integrated Fire & Audio panel
- Expansion to three 360 watts expansion cabinets for a total of 1260 watts of audio power per node

Network Features

- Up to 63 nodes
- Peer-to-peer network communications
- Fully integrated digital network audio and control over a single pair of copper wire or fiber optic cable
- Supports over 5,000 points per node
- Supports over 250,000 points on a single network
- Remote diagnostics via built in web server and standard Ethernet port in every node
- Style 4 (Class B) or Style 6 or 7 (Class A) wiring configuration
- Proprietary Arcnet Network Communications protocol



NYC
Fire Dept.
COA# 6064



CATALOG NUMBER **5940**

NOT TO BE USED FOR INSTALLATION PURPOSES.

Mircom reserves the right to make changes at any time without notice in prices, colours, materials, components, equipment, specifications and models and also to discontinue models.

FleX-Net Integrated Fire and Audio Control Panels

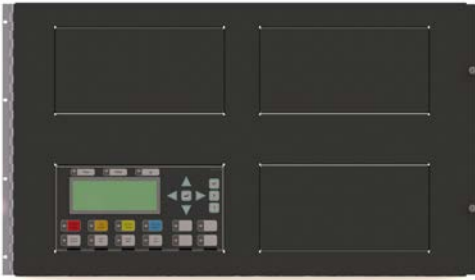

FX-2009-12NDS Large Network Main Control Unit

The FX-2009-12NDS Large Network Main Control Unit consists of a base fire alarm panel with one isolated intelligent Signaling Line Circuit (SLC) Style 4, 6 or 7, Four Style Z/Y (Class A/B) NAC circuits, a 4 line by 20 character LCD display and a 12 Amp power supply. The FX-2009-12NDS has space to mount the FNC-2000 Fire Network Controller Module, ANC-5000 Audio Network Controller Module, TNC-5000 Telephone Network Controller Module and provision to mount up to 4 adder modules. The FX-2009-12NDS mounts in a BB-5000 Series enclosure and supports Audio Lobby Control modules, Fire Fighter's Lobby Control modules and FX-2000 Internal Annunciator / Programmable modules.



ECX-0012 Expander Chassis

The ECX-0012 Expander Chassis for the FX-2009-12NDS supports up to 12 adder modules and has space for 2 internal annunciator modules. The ECX-0012 mounts in the BB-5000 series enclosures.



BB-5008/BB-5014 Enclosures

The BB-5008 and BB-5014 enclosures support the FX-2009-12NDS and provide space for internal lobby control modules. The cabinets hold up to 24 AH batteries. The door and chassis hardware are ordered separately.

BB-5008 Dimensions: 36"H x 30"W x 7"D

BB-5014 Dimensions: 60"H x 30"W x 7"D

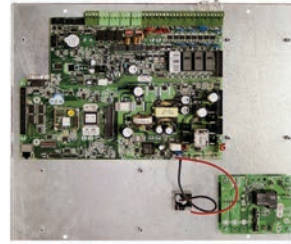

FX-2000MNS Main Network Board

The FX-2000MNS main network board includes one intelligent Signaling Line Circuit (SLC) and Four Style Z/Y (Class A/B) NAC circuits. The FX-2000MNS has provisions to mount up to 9 internal adder modules and mounts in the BBX-FXMNS enclosure.



QMB-5000N Integrated Audio Network Chassis

The QMB-5000N includes the audio and telephone control which consists of an audio card cage designed for mounting the ANC-5000 Audio Network Controller Module, TNC-5000 Telephone Network Controller Module and up to four QAA style audio amplifiers. The QMB-5000N connects to the FX-2000MNS main board and mounts in the BBX-FXMNS enclosures. The QMB-5000N supports audio expansion with connection to up to three QBB-5001 Audio Cabinets. Each QBB-5001 can support a maximum 360 watts.

Electrical Specifications

Fire Alarm Primary Input Power	120V 60Hz / 240V, 50Hz 4 Amps / 2 Amp (primary)
Power Supply Ratings	12 Amps. max. (secondary)
For NAC Circuits	24VDC unfiltered, 10 Amps. max.
Battery Type	24VDC, Gel-Cell/Sealed Lead-Acid
Battery Charging Capability	17-65 AH batteries
Audio Primary Input Power (QPS-5000N)	120 VAC, 60Hz / 240 VAC, 50Hz 12 Amps

FleX-Net Integrated Fire and Audio Control Panels



DSPL-420 Main Display Module

The DSPL-420 Main Display Module provides a 4 line by 20 character backlit LCD display, Common Control buttons and Four Status Queues with selector switches and LEDs for Alarm, Supervisory, Trouble and Monitor. The DSPL-420 occupies one display position in the BBX-FXMNS enclosure.



DSPL-2440 Graphical Main Display Module

The DSPL-2440 Graphical Main Display Module provides a 24 line x 40 character backlit LCD display, Common Controls buttons and Four Status Queues with selector switches and LEDs for Alarm, Supervisory, Trouble and Monitor. The DSPL-2440 occupies one display position in the BBX-FXMNS enclosure.



QMP-5101NV Network Master Paging Control Module

The QMP-5101NV Network Master Paging Control Module includes the paging microphone and common control indicators. The QMP-5101NV allows for all call paging or selective paging with the QAZT-5302DS Zoned Paging and Telephone Selector Modules. The QMP-5101NV is a vertical mount unit that mounts in the BBX-FXMNS enclosure.



QMT-5302NV Network Master Fire Fighters' Telephone Control Module

The QMT-5302NV includes the Master Telephone Handset and common control indicators. The QMT-5302NV supports the QAZT-5302DS Paging and Telephone selector modules. The QMT-5302NV is a vertical mount unit that mounts in the BBX-FXMNS enclosure.



BBX-FXMNS Enclosure

The BBX-FXMNS enclosure supports the FX-2000MNS Network main board, a DSPL-420 or DSPL-2440 Main LCD display, a QMB-5000N audio card cage, a QMP-5101NV Master Paging Microphone and a QMT-5302NV Master Telephone Handset. In addition the enclosure provides space for additional external modules and internal lobby control modules. The BBX-FXMNS holds up to 40 AH batteries and is available with a white (BBX-FXMNS) or red (BBX-FXMNSR) door.

BBX-FXMNS Dimensions: 61.5"H x 20"W x 9"D

Power Supply Expansion

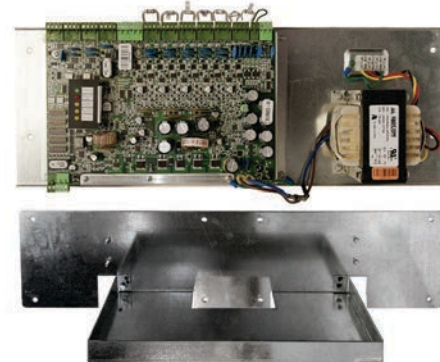

INX-10AC Internal Booster Power Supply Module

Mircom's INX-10AC is an Intelligent Booster Power Supply that extends the power capabilities of existing notification appliance circuits as well as provide power for other ancillary devices. The INX-10AC has 10 amps of power and mounts inside the BB-5014 enclosure.

Fire Network Controller Modules

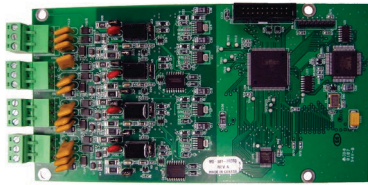

FNC-2000 Fire Network Controller Module

The FNC-2000 provides network capability to the FX-2009-12NDS. One Fire Network Controller Module is required per network node panel. In addition the FNC-2000 provides an interface for adding an optional FOM-2000-SP Fiber Optic Network Adder Module. The FNC-2000 mounts in the FX-2009-12NDS.

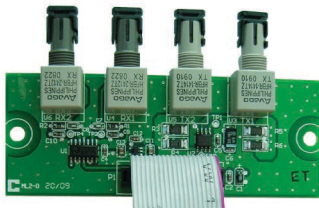

FOM-2000-SP Fiber Optic Network Adder Module

The FOM-2000-SP Fiber Optic Network Adder Module allows for the use of fiber optic cabling on the FX-2009-12NDS. It seamlessly connects to the interface on the FNC-2000 Fire Alarm Network Controller Module.

Adder Loop Controller Modules

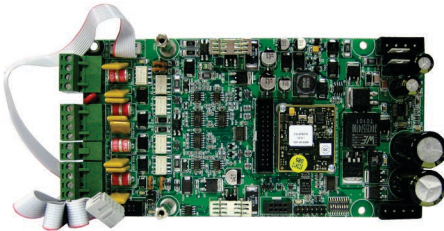

ALCN-792M Quad Loop Controller Module

The ALCN-792M Quad Loop Controller Module provides two Signaling Line Circuits (SLC) to the Flex-Net system consisting of 99 Analog Sensors and 99 Addressable Modules per loop. The ALCN-792M can be expanded with the use of the ALCN-792D Daughter Board Module. The ALCN-792M occupies one module slot.

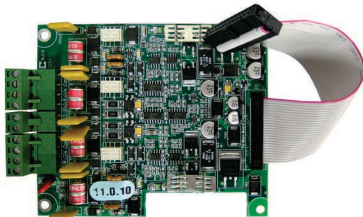

ALCN-792D Daughter board for Quad Loop Controller Module

The ALCN-792D Daughter Board provides an additional two SLC when connected to the ALCN-792M Quad Loop Controller Module. The daughter board mounts on top of the ALCN-792M.

Adder Hardware Modules

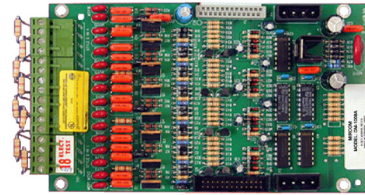

DM-1008A Eight Initiating Circuit Module

The DM-1008A provides 8 Style B (Class B) or 4 Style D (Class A) Initiating Circuits configurable for Alarm, Supervisory or Trouble zones. The DM-1008A occupies one module slot.

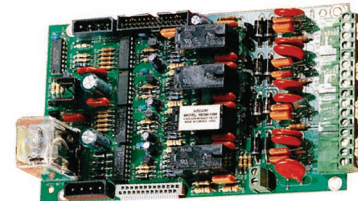

SGM-1004A Four Notification Appliance Circuit Module

The SGM-1004A provides 4 Style Z/Y (Class A/B) Notification Appliance Circuits configurable as Silenceable or Non-Silenceable. Each NAC circuit is rated at 1.7 Amps and has individual signal silence inputs (jumper selectable). The SGM-1004A occupies one module slot.

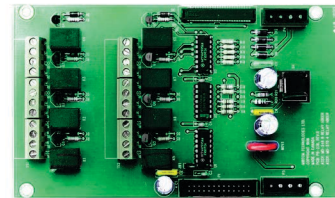

RM-1008A Eight Relay Circuit Module

The RM-1008A provides the system with eight individual configurable relays per module. Each relay provides one Form C contact rated at 28 VDC @1 Amp (resistive load) as well as a Green LED to indicate that the relay is active. The RM-1008A occupies one module slot.

Adder Auxiliary Modules

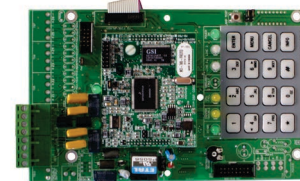

UDACT-300A Digital Alarm Communicator Module

The UDACT-300A Digital Communicator allows the system to transmit addressable point information to a central station. The UDACT-300A occupies one module slot.

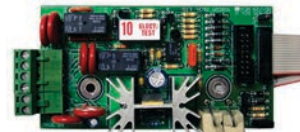

PR-300 Polarity Reversal/City Tie Module

The PR-300 Polarity Reversal/City Tie Module provides the system with a supervised City Tie (24 VDC/200 mA max.) and Polarity Reversal connection (24 VDC (open circuit), 8 mA max. (shorted)). The PR-300 occupies one module slot.

Remote LCD Annunciators



RAXN-LCD Remote LCD Annunciator

The RAXN-LCD Remote LCD Annunciator is equipped with a 4 line x 20 character back-lit alphanumeric LCD display that provides an exact replica of the main Flex-Net fire alarm control panel display. The RAXN-LCD occupies one display position in the BB-1000 or BB-5000 Series enclosures.



RAXN-LCDG Remote Graphic LCD Annunciator

The RAXN-LCDG Remote Graphic LCD Annunciator is equipped with a 24 line x 40 character back-lit graphical LCD display that is used to display 9 events per page. Each event is displayed over 2 lines with 40 characters per line allowing emergency information to be displayed in an easy to read format. The RAXN-LCDG occupies one display position in the BB-1000 or BB-5000 Series enclosures.

Remote LED Annunciators

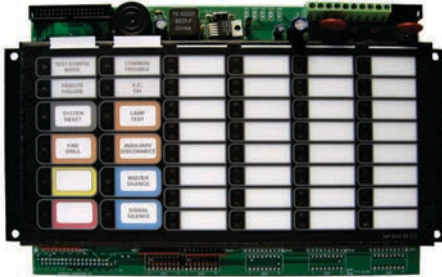

RAM-1032TZDS Main Remote LED Annunciator

The RAM-1032TZDS Main Remote LED Annunciator provides common annunciator functions and 32 points of LED annunciation. The RAM-1032TZDS has indicators for A.C. On, Common Trouble and Signal Silence and controls for System Reset, Lamp Test, Fire Drill, Buzzer Silence and Signal Silence. The RAM-1032TZDS occupies one display position in the BB-1000 or BB-5000 enclosures.

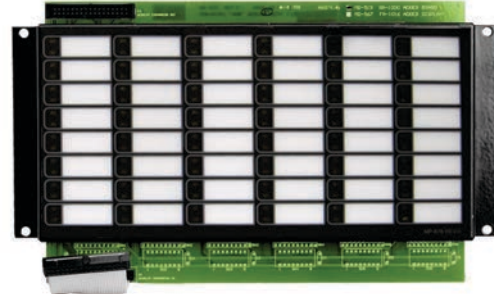

RAX-1048TZDS Programmable LED Annunciator Module

The RAX-1048TZDS Programmable LED Annunciator Module provides 48 programmable bi-colored LEDs. The RAX-1048TZDS connects to the main panel or either the RAXN-LCD or RAM-1032TZDS when mounted remotely. The RAX-1048TZDS occupies one display position in the BB-1000 or BB-5000 Series enclosures.

Graphic Annunciator Driver Modules

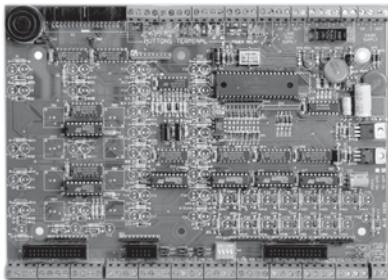

MGD-32 Master Graphic Driver Module

The MGD-32 Master Graphic Driver Module provides common control inputs for the common control switches such as System Reset, Signal Silence, Auxiliary Disconnect, Fire Drill, Lamp Test, Acknowledge and General Alarm. The MGD-32 can also drive up to 32 supervised outputs. These output points are capable of driving LEDs or incandescent lamps. The MGD-32 mounts in a graphic annunciator wallbox or in the BB-5000 enclosures. An external power supply is required for incandescent lamps and lamp test.

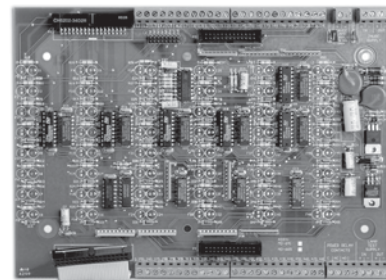

AGD-048 Adder Graphic Driver Module

The AGD-048 Adder Graphic Driver Module can be used with the MGD-32 to support an additional 48 supervised outputs. The AGD-048 mounts in a graphic annunciator wallbox or in the BB-5000 Series enclosures.

Programmable Modules



FDX-008 Fan Damper Control Module

The FDX-008 Fan Damper Control Module provides individually programmed circuits which can be used for fan or damper control. The FDX-008 connects to the main panel or the RAXN-LCD and occupies one display position in the BB-1000 or BB-5000 Series enclosures.

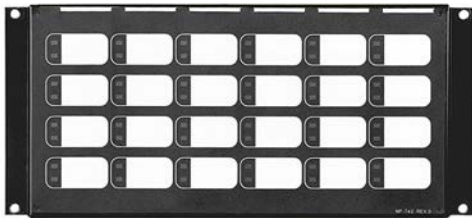

IPS-2424DS Programmable Input Switches Module

The IPS-2424DS provides 24 programmable switches that can be configured for ancillary functions such as zone bypass or added common control functions. The IPS-2424DS connects to main panel or the RAXN-LCD when mounted remotely. The IPS-2424DS occupies one display position in the BB-1000 or BB-5000 Series enclosures.

Mounting Brackets



M500-BK9 Module Mounting Bracket

The M500-BK9 Module Mounting Bracket mounts inside the BB-5000 Series enclosures and provides space to mount up to nine M500 style intelligent modules.



M500-BK2 Module Mounting Bracket

The M500-BK2 Module Mounting Bracket mounts inside the BBX-FXMNS enclosure and provides space to mount up to two M500 style intelligent modules.

Graphics Software



Open Graphic Navigator (OpenGN)

Mircom's Open Graphic Navigator (OpenGN) software is an advanced fire alarm management and warning system that provides building ready monitoring, control and software management solutions that allows a user to monitor remote sites from multiple operator workstations located anywhere in the world.

The OpenGN software is available in two versions: Network (OPENGN-ENT) and Non-Network (OPENGN-MINI) for use with the Mircom FX-2000 and Flex-Net Intelligent Fire Alarm Control panels.

Dimensions for Annunciator Module Enclosures

Model	Dimensions
BB-1001	9"H x 12.75"W x 1.2"D
BB-1002	18"H x 12.75"W x 1.2"D
BB-1003	26.4"H x 12.75"W x 1.2"D
BB-1008	33"H x 22.5"W x 1.25"D
BB-1012	45"H x 22.5"W x 1.25"D

Flex-Net Audio and Telephone Network Controller Modules



ANC-5000 Audio Network Controller Module

The ANC-5000 provides audio microphone control on the network system. The ANC-5000 mounts on a plate in the FX-2009-12NDS or QMB-5000N.

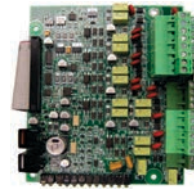

TNC-5000 Telephone Network Controller Module

The TNC-5000 provides five hardwired telephone circuits for the local floor panel with the first circuit configurable for the master telephone handset. The TNC-5000 mounts in the FX-2009-12NDS or QMB-5000N.

Paging & Telephone Control Modules



QMP-5101N Network Master Paging Control Module

The QMP-5101N Network Master Paging Control Module includes the paging microphone and common control indicators. The QMP-5101N allows for all call paging or selective paging with the QAZT-5302DS Zoned Paging and Telephone Selector Modules. The QMP-5101N occupies one module space in the BB-5000 Series enclosures.



QMT-5302N Network Master Firefighters' Telephone Control Module

The QMT-5302N includes the Master Telephone Handset and common control indicators. The QMT-5302N supports the QAZT-5302DS Paging and Telephone selector modules. The QMT-5302N occupies one module space in the BB-5000 Series enclosures.

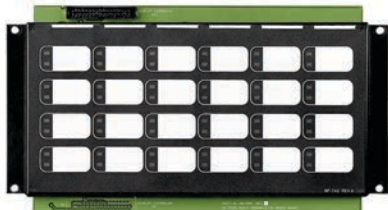

QAZT-5302DS Zoned Paging/Telephone Selector Module

The QAZT-5302DS Zoned Paging and Telephone Selector Module includes 24 zone selector switches and LEDs. The QAZT-5302DS is used with the QMP-5101N Network Master Paging Control module or QMT-5302 Network Master Firefighters' Telephone module. Slide-in labels are provided to label the selector zones. The QAZT-5302DS occupies one module space in the BB-1000 or BB-5000 Series enclosures.

Audio Expansion

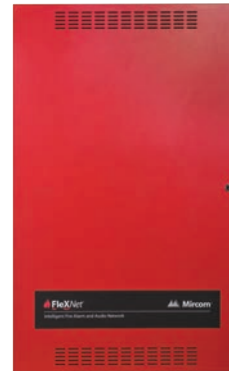

QBB-5001 Audio Backbox

The QBB-5001 holds one QMB-5000B Audio Motherboard and Card Cage, one QPS-5000N Audio Power Supply, one QBC-5000N Audio Battery Charger and up to 40 Ah batteries.

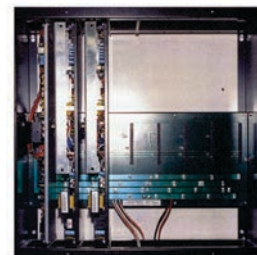

QMB-5000B Audio Motherboard and Card Cage

The QMB-5000B supports 7 QAA style audio amplifiers. The QMB-5000B requires one QPS-5000N Audio Power Supply and one QBC-5000N Audio Battery Charger and mounts in the QBB-5001 backbox.



QPS-5000N Audio Power Supply

The QPS-5000N supports up to 360 watts and mounts in the QBB-5001 Audio backbox.



QBC-5000N Audio Battery Charger

The QBC-5000N will charge up to 65 Ah batteries and mounts in QBB-5001 Audio Backbox.

Note: The QBB-5001 Audio Backbox will hold up to 40 Ah batteries. Larger batteries will require a BC-160 Battery Cabinet.

Audio Amplifiers



QAA-5415-70 and QAA-5415-25 Quad 15 Watt Amplifiers

The QAA-5415-70 and QAA-5415-25 consist of four 15 watt supervised paging/speaker circuits which can be wired in Class 'B' (Style 'Y') only. The QAA-5415-70 is a 70 Volt amplifier and the QAA-5415-25 is a 25 Volt amplifier. Both models mount in either the QMB-5000N or QMB-5000B card cage and occupy one amplifier slot.

QAA-5230S-70/25 Dual 30 Watt Amplifier

The QAA-5230S-70/25 consists of two 25 or 70 Volt 30 watt amplifiers. Each amplifier has two 15 watt supervised speaker outputs which are used for 'A' 'B' speakers per floor and are wired in Class 'B' (Style 'Y') only. The QAA-5230S-70/25 mounts in either the QMB-5000N or QMB-5000B card cage and occupies one amplifier slot.

QAA-5230-70/25 Dual 30 Watt Amplifier

The QAA-5230-70/25 consists of two 25 or 70 Volt 30 watt supervised paging/speaker circuits which can be wired in Class 'A' (Style 'Z') or Class 'B' (Style 'Y'). The QAA-5230-70/25 mounts in either the QMB-5000N or QMB-5000B card cage and occupies one amplifier slot.

QAA-5160-70/25 60 Watt Amplifier

The QAA-5160-70/25 consists of one 25 or 70 Volt 60 watt supervised paging/speaker circuit which can be wired in Class 'A' (Style 'Z') or Class 'B' (Style 'Y'). The QAA-5160-70/25 mounts in either the QMB-5000N or QMB-5000B card cage and occupies one amplifier slot.

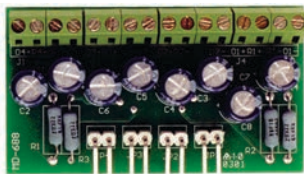

QAA-4CLA Class 'A' (Style 'Z') Converter Module

The QAA-4CLA converts each of the four Class 'B' (Style 'Y') outputs on a QAA-5415-70 or QAA-5415-25 Amplifiers to Class 'A' (Style 'Z'). The module attaches to the bottom of the amplifier. One QAA-4CLA is required for each amplifier.

QAA-4CLAS Class 'A' (Style 'Z') Converter Module

The QAA-4CLAS converts each of the four Class 'B' (Style 'Y') outputs on a QAA-5230S-70/25 or QAA-5230S-525-70/25 Amplifier to Class 'A' (Style 'Z'). The module attaches to the bottom of the amplifier. One QAA-4CLAS is required for each amplifier.

QAA 5415-70 or QAA-5415-25 Wiring Diagram

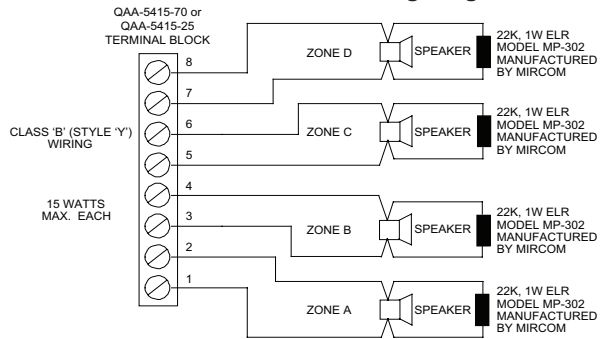

QAA-5230S-70/25 Wiring Diagram

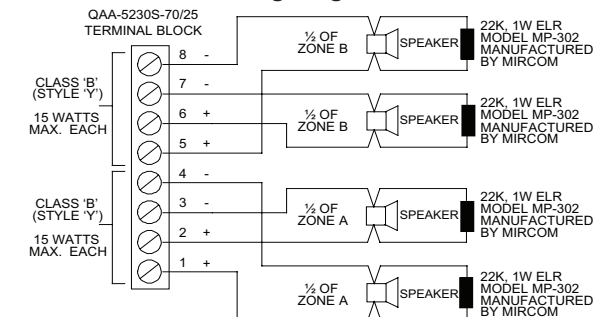

QAA-5230-70/25 Wiring Diagram

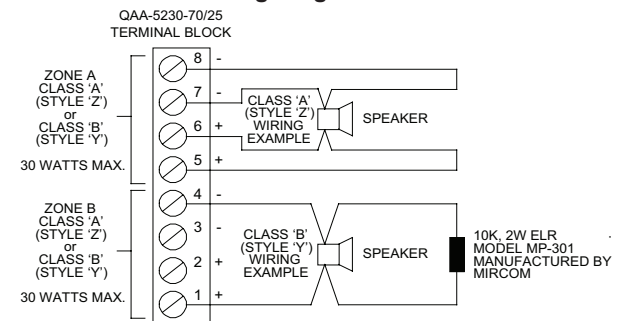

QAA-5160-70/25 Wiring Diagram

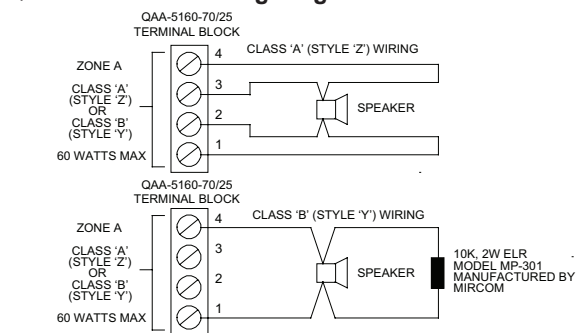

QAA-4CLA and QAA-4CLAS Connection Diagram

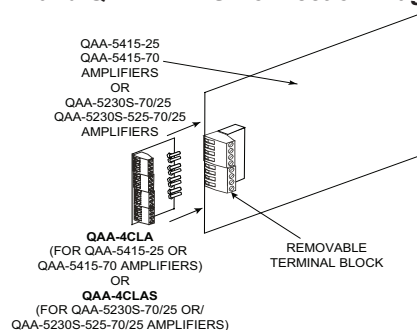

Typical Flex-Net Networked System Configuration with Audio

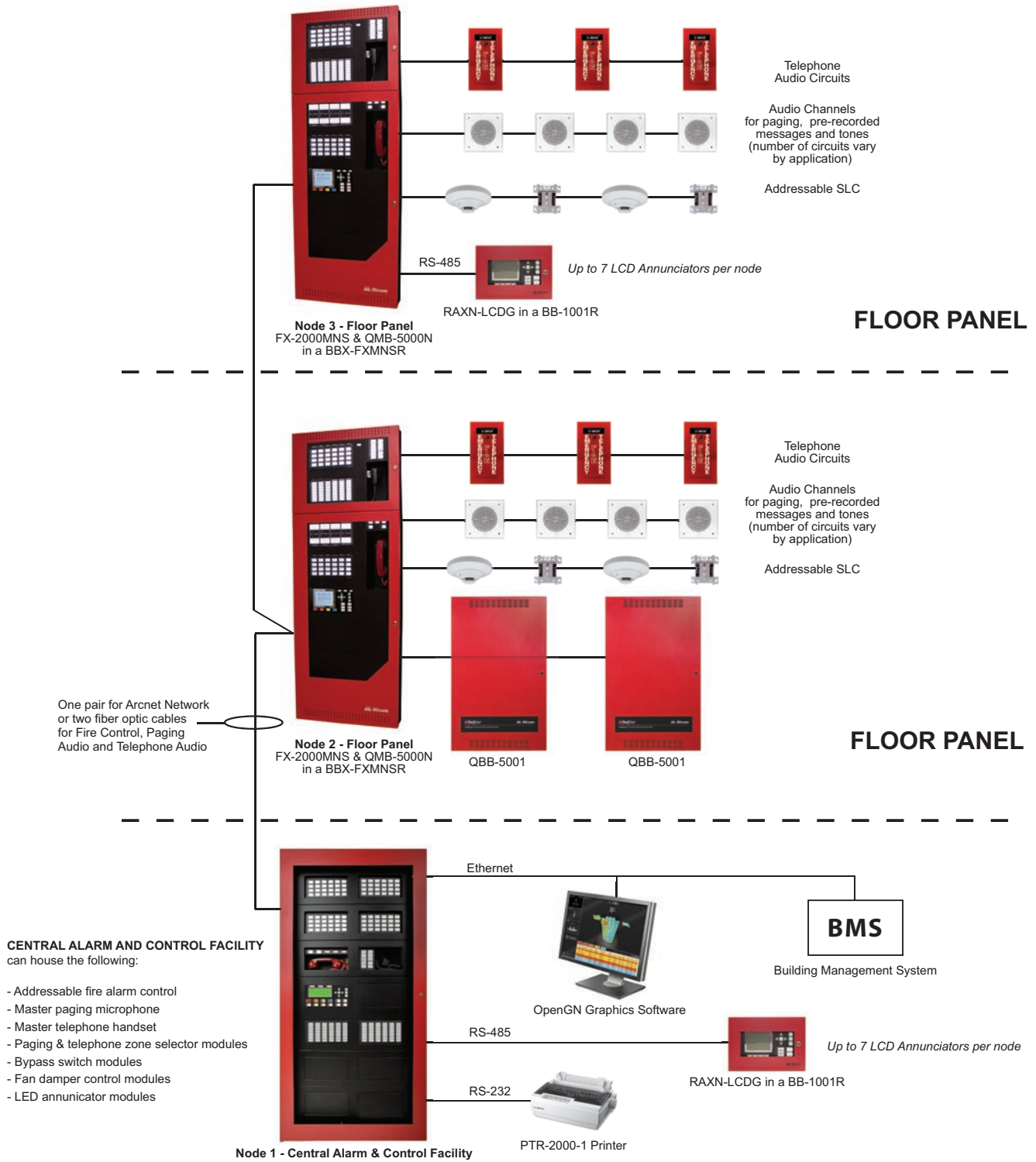

Current Consumption

Model Number	Description	Standby (Amps)	Alarm (Amps)
Fire Alarm Components			
FX-2000MNS	Main Network Control Unit on a Chassis (12 Amp)	0.310	0.733
FX-2003-12NDS	Compact Main Network Control Unit (12 Amp)	0.310	0.733
FX-2017-12NDS	Mid-Size Main Network Control Unit (12 Amp)	0.310	0.733
FX-2009-12NDS	Large Main Network Control Unit (12 Amp)	0.310	0.733
ALCN-792M	Quad Loop Controller Module	0.130	0.145
ALCN-792M /w ALCN-792D	Quad Loop Controller Module with Daughter Module	0.130	0.145
FNC-2000	Fire Network Controller Module	0.190	0.0190
ANC-5000	Audio Network Controller Module	0.255	0.265
TNC-5000	Telephone Network Controller Module	0.195	0.215
FOM-2000-SP	Fiber Optics Module	0.015	0.015
DM-1008A	8 Initiating Circuit Module	0.080	1 zone active: 0.125 2 zone active: 0.170 4 zone active: 0.275 6 zone active: 0.370 8 zone active: 0.465
SGM-1004A	4 Notification Appliance Circuit Module	0.060	0.258
RM-1008A	8 Relay Circuit Module	0.025	0.150
FDX-008	Fan Damper Control Module	0.015	0.035
DSPL-420	Narrow Display	0.024	0.025
DSPL-2440	Graphic Display	0.029	0.035
UDACT-300A	Dialer Module	0.045	0.120
PR-300	City Tie Module	0.035	0.300
FDS-008	Selection Control Panel for MNS	0.024	0.112
RAX-1048TZDS	Adder Annunciator Chassis	0.022	1 zone active: 0.026 2 zone active: 0.030 3 zone active: 0.035 4 zone active: 0.039 48 zone active: 0.262
RAM-1032TZDS	Adder Annunciator Chassis	0.050	32 zone active: 0.300
AGD-048	Adder Graphic Driver Board	0.035	# of LEDs x 4mA
IPS-2424DS	Programmable Input Switches Module	0.010	0.015
Audio Components			
ANC-5000	Audio Network Controller Module	0.255	0.265
TNC-5000	Telephone Network Controller Module	0.195	0.215
QAA-5160-70/25	1 Zone 60W Amplifier	0.055	0.350
QAA-5230-70/25	2 Zone 30W Amplifier	0.055	0.350
QAA-5230S-70/25	2 Zone 30W Amplifier (split)	0.055	0.350
QAA-5415-70	4 Zone 15W Amplifier, 70V	0.055	0.350
QAA-5415-25	4 Zone 15W Amplifier, 25V	0.055	0.350
QMP-5101N	Master Paging Module	0.004	0.012
QMP-5101NV	Vertical Master Paging Module	0.004	0.012
QMT-5302N	Master Telephone Module	0.003	0.013
QMT-5302NV	Vertical Master Telephone Module	0.003	0.013
QAZT-5302DS	Paging/Telephone Zone Module	0.010	0.015

Ordering Information

Model	Description
Flex-Net Network Lobby Control and Floor Panels - Integrated Fire and Audio Systems	
FX-2009-12NDS	Large Network Main Control Unit. Mounts in the BB-5000 series enclosures.
ECX-0012	Expander Chassis for the FX-2009-12NDS. Mounts in the BB-5000 series enclosures.
FX-2000MNS	Main Network Board with one SLC loop. Mounts in the BBX-FXMNS enclosure.
DSPL-420	4 x 20 Main LCD Display for FX-2000MNS
DSPL-2440	Graphical Main Display for FX-2000MNS
QMB-5000N	Integrated Audio Network Control Chassis
PS-2040	Network Fire Alarm and Audio Power Supply
Enclosures	
BB-5008	Lobby Control Wallbox Enclosure. Supports 8 Module Footprints.
DOX-5008M	White Metal Door for BB-5008. Add suffix 'R' for red enclosure.
CCH-5008	Custom Mounting Kit for BB-5008. One required per BB-5008.
BB-5014	Lobby Control Wallbox Enclosure. Supports 14 Module Footprints.
DOX-5014M	White Metal Door for BB-5014. Add suffix 'R' for red enclosure.
CCH-5014	Custom Mounting Kit for BB-5014. One required per BB-5014.
BBX-FXMNS	Black backbox enclosure with white doors for FX-2000MNS. Add suffix 'R' for red doors.
Adder Loop Controller Modules	
ALC-792M	Network Quad Loop Controller Module
ALC-792D	Daughter board for ALC-792M Quad Loop Controller Module
Adder Hardware Modules	
DM-1008A	Eight Class B (Style B) or 4 Class A (Style D) Initiating Circuit Module
SGM-1004A	Four Class A/B (Style Z/Y) Notification Appliance Circuit Module (Rated at 1.7 Amps per circuit)
RM-1008A	Eight Relay Circuit Module c/w eight form C relays (Rated for 28 VDC @ 1 Amp max. per relay)
Adder Auxiliary Modules	
UDACT-300A	Digital Alarm Communicator Transmitter/Dialer Module
PR-300	Polarity Reversal and City Tie Module
Programmable Modules	
IPS-2424DS	Programmable Input Switches Module c/w 24 selector switches and 24 bi-coloured LEDs
FDX-008	Fan Damper Control Module c/w 8 programmable switches
Power Module	
INX-10AC	Internal Booster Power Supply Module
Remote Annunciators	
RAXN-LCD	Remote LCD Annunciator
RAXN-LCDG	Remote Graphic LCD Annunciator
RAM-1032TZDS	Main Remote LED Annunciator c/w 32 Bi-Colored LEDs
RAX-1048TZDS	Adder Annunciator Chassis c/w 48 Bi-Colored LEDs

Graphic Annunciator Driver Modules	
MGD-32	Main Graphic Driver Module c/w 32 Supervised Outputs
AGD-048	Adder Graphic Driver Module c/w 48 Supervised Outputs
Network Controller Modules	
FNC-2000	Fire Network Controller Module
FOM-2000-SP	Fiber Optic Network Adder Module
ANC-5000	Audio Network Controller Module
TNC-5000	Telephone Network Controller Module
Paging and Telephone Control Modules	
QMP-5101NV	Master Network Paging Control Module for FXMNS, Vertical Mount. For use in BBX-FXMNS.
QMT-5302NV	Master Network Telephone Module for FXMNS, Vertical Mount. For use in BBX-FXMNS.
QMP-5101N	Master Network Paging Control Module
QMT-5302N	Master Network Telephone Control Module
QAZT-5302DS	Paging and Telephone Selector Panel
Audio Amplifiers	
QAA-5415-70	70 Volt Quad 15 Watt Amplifier
QAA-5415-25	25 Volt Quad 15 Watt Amplifier
QAA-4CLA	Class 'A' (Style 'Z') Converter Module for QAA-5415-25 and QAA-5415-70 Amplifiers
QAA-5230S-70/25	25 or 70 Volt Dual 30 Watt Amplifier split 'A' 'B' circuits per floor
QAA-4CLAS	Class 'A' (Style 'Z') Converter Module for QAA-5230S-70/25 and QAA-5230S-525-70/25
QAA-5230-70/25	25 or 70 Volt Dual 30 Watt Amplifier
QAA-5160-70/25	25 or 70 Volt 60 Watt Amplifier
Enclosures for Remote Annunciators / Programmable Modules	
BB-1001	Remote Annunciator/Programmable Module Enclosure Houses one module. Add suffix "R" for red door.
BB-1002	Remote Annunciator/Programmable Module Enclosure Houses two modules. Add suffix "R" for red door.
BB-1003	Remote Annunciator/Programmable Module Enclosure Houses three modules. Add suffix "R" for red door.
BB-1008	Remote Annunciator/Programmable Module Enclosure Houses eight modules. Add suffix "R" for red door.
BB-1012	Remote Annunciator/Programmable Module Enclosure Houses twelve modules. Add suffix "R" for red door.
Audio Expansion Components	
QMB-5000B	Audio Motherboard and Card Cage
QPS-5000N	Audio Power Supply
QBC-5000N	Audio Battery Charger
QBB-5001	Audio Backbox
Graphics Software	
OPENGN-MINI	Open Graphic Navigator Software, Mini Edition for standalone Flex-Net Systems
OPENGN-ENT	Open Graphic Navigator Software, Enterprise Edition for Flex-Net Network Systems

This Page Left Intentionally Blank

NOT TO BE USED FOR INSTALLATION PURPOSES.



Canada
25 Interchange Way
Vaughan, Ontario L4K 5W3
Telephone: (905) 660-4655
Fax: (905) 660-4113

U.S.A.
4575 Witmer Industrial Estates
Niagara Falls, NY 14305
Toll Free: (888) 660-4655
Fax Toll Free: (888) 660-4113

Web page: <http://www.mircom.com> Email: mail@mircom.com

Distributed by:

ISO 9001:2008
REGISTERED



CAT. 5940
Rev. 6

GP 12650

12V 65Ah

GP 12650 is a general purpose battery up to 5 years in standby service or more than 260 cycles at 100% discharge in cycle service. As with all CSB batteries, all are rechargeable, highly efficient, leak proof and maintenance free.



Specification

Cells Per Unit	6
Voltage Per Unit	12
Capacity	65Ah @ 20hr-rate to 1.75V per cell @25 °C (77°F)
Weight	Approx. 20 kg(44.09 lbs)
Maximum Discharge Current	500A(5sec)
Internal Resistance	Approx. 6 mΩ
Operating Temperature Range	Discharge: -15°C~50°C (5°F~122°F) Charge: -15 °C~40°C (5°F~104°F) Storage: -15°C~40°C (5°F~104°F)
Nominal Operating Temperature Range	25°C±3°C(77°F±5°F)
Float Charging Voltage	13.5 to 13.8 VDC/unit Average at 25°C(77°F)
Recommended Maximum Charging	19.5A
Current Limi	
Equalization and Cycle Service	14.4 to 15.0 VDC/unit Average at 25°C(77°F)
Self Discharge	CSB Batteries can be stored for more than 6 months at 25°C(77°F). Please charge batteries before using. For higher temperatures the time interval will be shorter.
Terminal	B4-L terminal to accept M6 nut & bolt
Container Material	Polypropylene(UL 94-V0/File E50955)*Flammability resistance of (UL 94-HB/File E216959) can be available upon request.



CSB-manufactured batteries are UL-recognized components under UL924 and UL1989. CSB is also certified by ISO 9001 and ISO 14001.

Dimensions

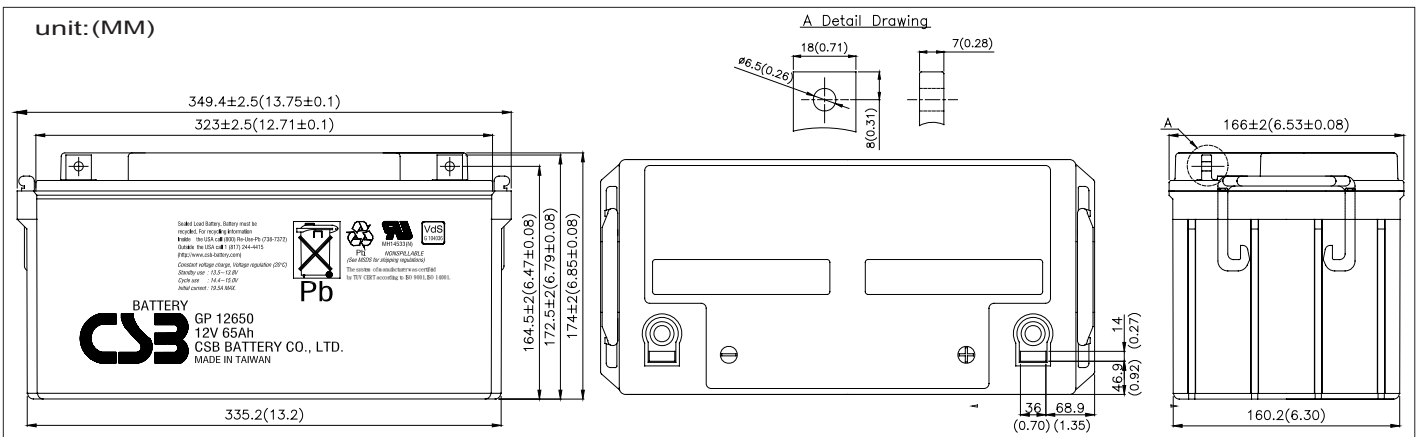

Constant Current Discharge Characteristics Unit:A (25°C,77°F)

F.V/Time	5MIN	10MIN	15MIN	30MIN	1HR	2HR	3HR	4HR	5HR	8HR	10HR	20HR
1.60V	271	173	132	79.9	47.2	27.3	19.4	15.1	12.4	8.08	6.58	3.57
1.67V	242	162	124	78.3	46.9	27.2	19.3	15.0	12.3	7.98	6.48	3.42
1.70V	229	157	121	77.3	46.7	27.1	19.2	14.9	12.2	7.93	6.43	3.36
1.75V	208	147	117	75.4	46.4	27.0	19.1	14.8	12.1	7.86	6.32	3.25
1.80V	186	137	111	73.4	45.9	26.9	19.0	14.7	12.0	7.76	6.21	3.14
1.85V	164	127	105	71.3	45.4	26.8	18.9	14.6	11.9	7.66	6.10	3.03

Constant Power Discharge Characteristics Unit:W (25°C,77°F)

F.V/Time	5MIN	10MIN	15MIN	30MIN	1HR	2HR	3HR	4HR	5HR	8HR	10HR	20HR
1.60V	3,250	2,080	1,580	959	566	327	232	181	148	97.0	79.0	40.9
1.67V	2,900	1,940	1,503	935	562	326	231	180	147	96.0	77.7	39.2
1.70V	2,750	1,871	1,460	924	560	325	230	179	146	95.5	77.1	38.4
1.75V	2,490	1,760	1,400	903	555	324	229	178	145	94.3	75.8	37.1
1.80V	2,230	1,640	1,330	881	550	323	228	177	144	93.1	74.5	35.7
1.85V	1,970	1,520	1,260	856	545	322	227	176	143	91.9	73.2	34.4

• All mentioned values are average values.

Trickle (or Float) Service Life

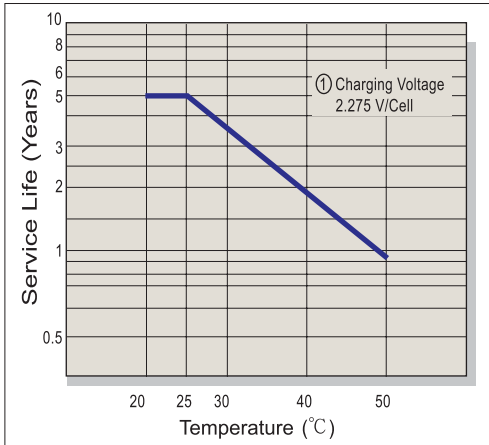

Capacity Retention Characteristic

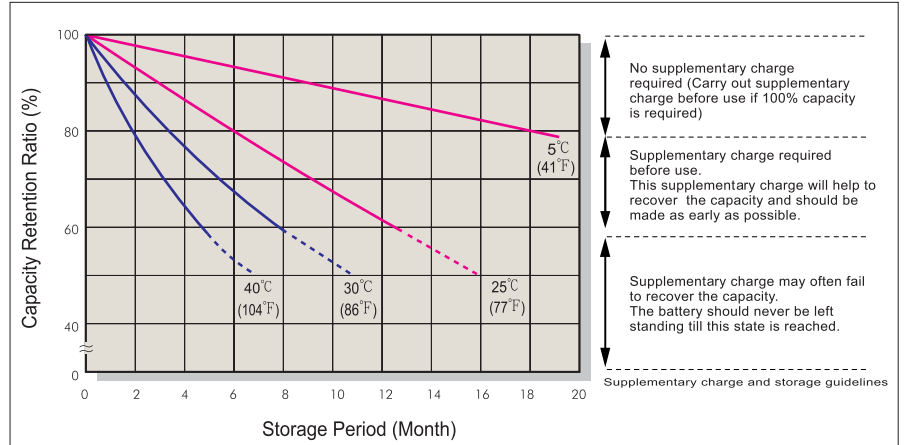

Battery Voltage and Charge Time for Standby Use

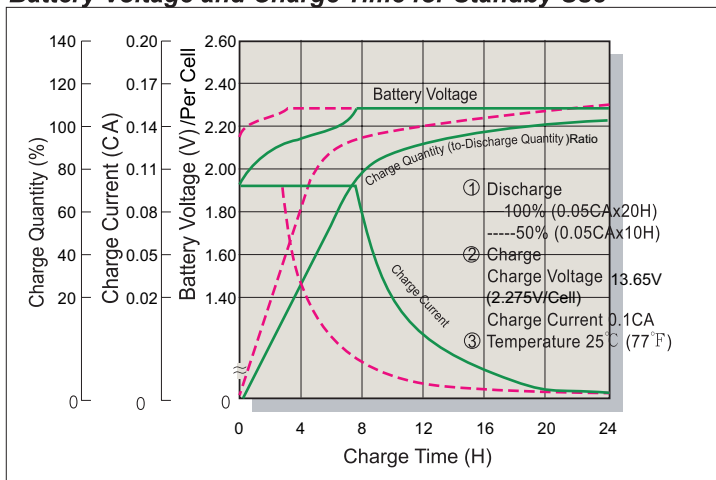

Cycle Service Life

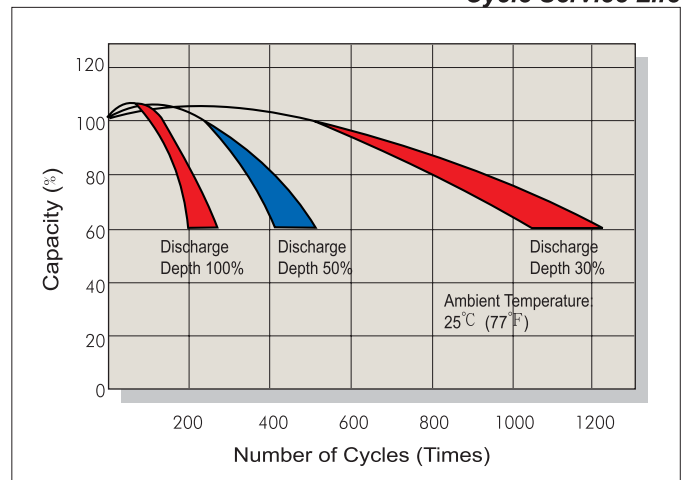

Battery Voltage and Charge Time for Cycle Use

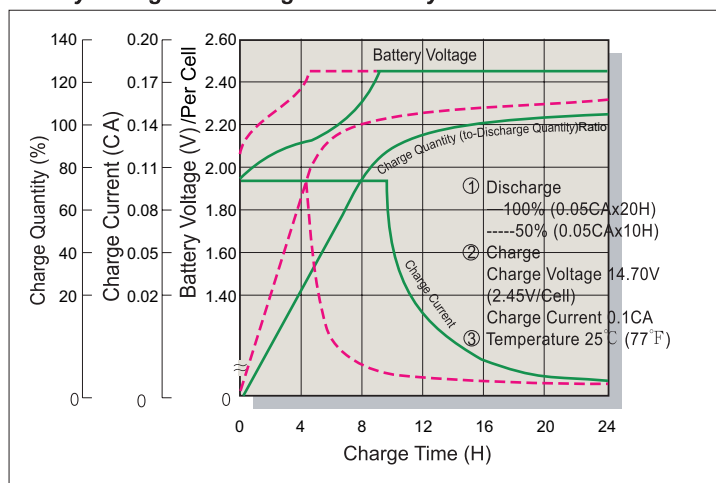

Terminal Voltage (V) and Discharge Time

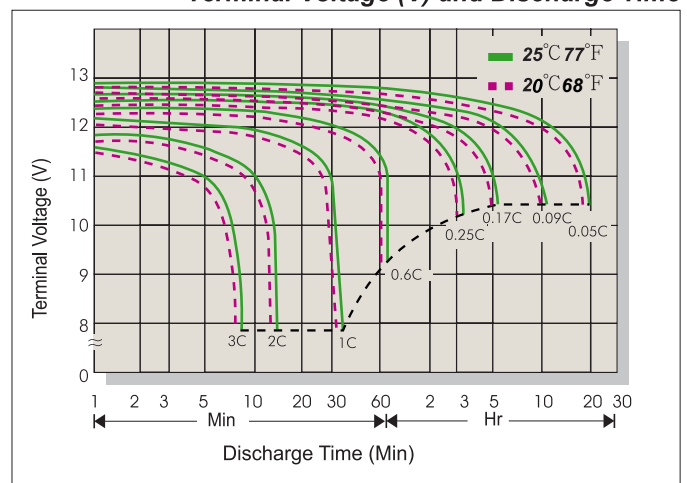

Charging Procedures

Application	Charge Voltage(V/Cell)			Max.Charge Current
	Temperature	Set Point	Allowable Range	
Cycle Use	25°C (77°F)	2.45	2.40~2.50	0.3C
Standby	25°C (77°F)	2.275	2.25~2.30	

Discharge Current VS. Discharge Voltage

Final Discharge Voltage V/Cell	1.75	1.70	1.60	1.30
Discharge Current(A)	0.2C>(A)	0.2C<(A)<0.5C	0.5C<(A)<1.0C	(A)>1.0C

Sales Office URL: WWW.CSB-BATTERY.COM

CSB BATTERY CO., LTD.
TAIWAN OFFICE
Tel: +886-2-2555-5600
Fax: +886-2-2555-3300
E-mail: service@csb-battery.com.tw

CSB BATTERY LOGISTICS (SHANGHAI) CO., LTD.
SHANGHAI OFFICE
Tel: +86-21-5046-1622, 5046-0833
Fax: +86-21-5064-3314
E-mail: chinasls@csb-battery.com

CSB BATTERY TECHNOLOGIES, INC
USA OFFICE
Tel: +1-817-244-7777/1-8003 CSBUSA(272872)
Fax: +1-817-244-4445
E-mail: csb@csb-battery.com

CSB BATTERY LOGISTICS (SHANGHAI) CO., LTD.
BEIJING OFFICE
Tel: +86-10-6597-8060, 6597-8070
Fax: +86-10-6597-8050
E-mail: chinasls@csb-battery.com

CSB BATTERY OF NETHERLANDS B.V
NETHERLANDS OFFICE
Tel: +31(0) 180 418 140
Fax: +31(0) 180 418 327
E-mail: eurosales@csb-battery.com

CSB BATTERY LOGISTICS (SHANGHAI) CO., LTD.
SHENZHEN OFFICE
Tel: +86-755-8831-6488/6396/16356
Fax: +86-755-8831-6548
E-mail: she@csb-battery.com.cn

INX-10A Intelligent NAC Expander/Power Supply



Description

The INX-10A is an Intelligent NAC expander/power supply that is compatible with the Secutron's MR-2100, MR-2200 and MR-2900 Series Intelligent fire alarm control panels. Available in a 10 Amp configuration, the INX-10A can extend the power capabilities of existing notification appliance circuits as well as provide power for other ancillary devices. In addition, the INX-10A has the ability to operate with any UL/ULC Listed 24 VDC conventional fire alarm control panel to provide Notification Appliance Circuit expansion.

The INX-10A is equipped with five individual Class B (Style Y) or Class A (Style Z) output circuits that can be independently configured for NAC operation or auxiliary power. The INX-10A provides the option of configuring all five circuits as an output to provide general purpose power. In addition output circuits four and five can be configured to provide auxiliary power for four-wire detectors or door holders.

Each output circuit is rated for 2.5 Amps. When configured for NAC operation the outputs can be set for Steady, Temporal Code, California Code or March Time. In addition the output circuits have field selectable built-in strobe and horn synchronization protocols to support Amseco, System Sensor, Wheelock and Gentex devices, eliminating the need for additional external synchronization modules.

Features

- 10 Amp output
- 120 / 240V operation
- Compatible with Secutron's MR-2100, MR-2200 and MR-2900 Series Intelligent Fire Alarm Control panels
- Easily configured using DIP switches
- One isolated input from the host panel
- Five Class B (Style Y) or Class A (Style Z) synchronized output circuits
- DC regulated outputs
- Configurable AC Power fail delay
- Ground fault enable or disable
- Option available on configuration to enable or disable the battery charger on activation
- From 7 to 15 Address functions (Combination of inputs and outputs, depending on the application)
- Outputs individually controllable
- Separate Relay for Ground Fault and Common Trouble available on terminals
- Horn/Strobe synchronization protocols include Amseco, Gentex, System Sensor and Wheelock
- Two-wire horn/strobe Sync Mode allows audible notification appliances (horns) to be silenced while visual notification appliances (strobes) continue to operate
- Audible signals may be configured for Steady, Temporal Code, California Code and March Time
- Output circuits four and five can be configured to provide auxiliary power for four-wire detectors or door holders.
- Canadian two stage operation
- Output fault notification to fire alarm control panel
- Ability to sync outputs for multiple INX-10A units
- 2.5 Amp max. current per output
- 1.7 Amp auxiliary power output
- Built-in charger for sealed lead acid or gel type batteries
- Unit includes power supply, charger, red enclosure, cam lock, transformer and battery leads
- Compatible with any UL/ULC listed 24VDC conventional fire alarm control panel to provide Notification Appliance Circuit expansion



S5434



S5434



7315-1477-0163

Modes of Operation

Intelligent NAC Expander (INX) Modes

The INX-10A features three modes of NAC Expander operation:

- INX Mode with Internal Sync
- INX Mode with External Sync
- INX Mode with Redundant Input

Input Mode with Internal Sync

In this mode all signal and sync strobe rates are produced in the INX-10A.

INX Mode with External Sync

When one of the Sync Inputs is activated, the INX-10A outputs follow the signal pattern of the Sync Input. The INX-10A must be configured as a slave to operate in this mode.

INX Mode with Redundant Input

The system continuously monitors the SLC loop. If there is no activity for a notable time, an SLC trouble is generated. While the SLC trouble is active, if either of the Sync Inputs are activated then all NAC outputs follow.

Power Supply Modes

In addition to the NAC expander modes, some or all of the NAC outputs on the INX-10A can be configured for the following power supply modes of operation:

- NAC Outputs as Power Supply Outputs
- NAC Outputs for Door Release
- NAC Outputs for 4-Wire Smoke Supply

NAC Outputs as Power Supply Outputs

This mode allows any NAC output to be configured as a power supply. The SLC and Sync inputs are ignored for the power supply outputs.

NAC Outputs for Door Release

This mode allows NAC circuits 4 and/or 5 to provide power for door holders.

NAC Outputs for 4-Wire Smoke Supply

This mode allows NAC circuits 4 and/or 5 to provide auxiliary power for 4-wire smoke detectors.

Specifications

Dimensions	
20"H x 14½"W x 4½"D	
AC Line Voltage	
120V 60Hz / 240V, 50Hz 2 Amps / 1 Amp (primary)	
NAC Circuits	
24VDC regulated, Power Limited 10A Total, 2.5A maximum per circuit	
Battery	
24VDC, Gel-Cell/Sealed Lead-Acid	
Charging Capability	
Up to 40 AH batteries	
Current Consumption	
Standby	200 mA
Alarm	350 mA

Common Indicators	
Power On Addressable Line Activity/Alarm Common Trouble Battery Charger/Trouble CPU Fail	
Trouble LEDs	
Auxiliary Output Trouble Synchronized Output Trouble Ground Fault Trouble	
Other LEDs	
Addressable (SLC) Loop Indicators (3 LEDs) Synchronized Input Indicators (2 LEDs) Synchronized Output Indicators (2 LEDs) Trouble LED Indicator Alarm Relay Indicator	
Controls	
Acknowledge Button Configuration DIP Switches	

Ordering Information

Model	Description
INX-10A	Intelligent NAC Expander, 10 Amps c/w backbox and red door



Sealed Lead-Acid Battery

UPG No. D5745

UB12180

Maintenance-Free

Absorbant Glass Mat (AGM) technology for superior performance. Valve regulated, spill proof construction allows safe operation in any position. Approved for transport by air. D.O.T., I.A.T.A., F.A.A. and C.A.B. certified. U.L. recognized under file number MH 20567.

Specification

Nominal Voltage	12 volts		
Nominal Capacity	77° F (25° C)		
20-hr. (0.90A)	18 Ah		
10-hr. (1.67A)	16.74 Ah		
5-hr. (3.06A)	15.30 Ah		
1-hr. (10.80A)	10.80 Ah		
Approximate Weight	11.7 lbs (5.3 kgs)		
Internal Resistance (approx.)	18mΩ		
Shelf Life (% of normal capacity at 77° F (25° C))			
3 Months	6 Months	12 Months	
91%	82%	64%	
Temperature Dependency of Capacity	(20 hour rate)		
104° F	77° F	32° F	5° F
102%	100%	85%	65%



Charge Method (Constant Voltage)

Cycle Use (Repeating Use)

Initial Current	6.3 A or smaller
Control Voltage	14.5 - 14.9 V

Float Use

Control Voltage	13.6 - 13.8 V
-----------------	---------------

Physical Dimensions: in (mm)

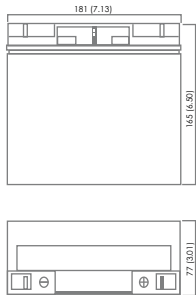

L: 7.13in (181.1 mm)
W: 3.01in (76.5 mm)
H: 6.50in (165.1 mm)
TH: 6.57in (166.9 mm)
 Tolerances are +/- 0.04 in. (+/- 1mm) and +/- 0.08 in. (+/- 2mm) for height dimensions. All data subject to change without notice.

Terminals

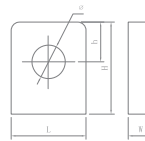

L Series (L Type Terminal)

Dimension Type	L	W	H	h	∅
L3	25.5	7.0	22.0	10.5	8.5
L4	26.5	8.0	24.5	12.0	9.0

Constant Current Discharge Characteristics Unit:A (25°C, 77°F)

F.V/Time	5MIN	10MIN	15MIN	30MIN	1HR	2HR	3HR	4HR	5HR	8HR	10HR	20HR
1.60V	48.2	31.4	24.1	14.8	8.83	5.12	3.66	2.89	2.33	1.53	1.23	0.645
1.67V	44.6	30.0	23.1	14.6	8.86	5.03	3.64	2.88	2.32	1.52	1.22	0.624
1.70V	42.9	28.2	22.7	14.5	8.57	5.00	3.63	2.87	2.31	1.51	1.21	0.615
1.75V	39.9	28.0	22.0	14.3	8.45	4.92	3.61	2.86	2.30	1.50	1.20	0.600
1.80V	36.9	26.7	21.3	14.0	8.30	4.82	3.60	2.84	2.28	1.49	1.18	0.585
1.85V	33.9	25.3	20.6	13.8	8.16	4.80	3.58	2.82	2.27	1.48	1.17	0.570

Constant Power Discharge Characteristics Unit:W (25°C, 77°F)

F.V/Time	5MIN	10MIN	15MIN	30MIN	1HR	2HR	3HR	4HR	5HR	8HR	10HR	20HR
1.60V	48.2	31.4	24.1	14.8	8.83	5.12	3.66	2.89	2.33	1.53	1.23	0.645
1.67V	44.6	30.0	23.1	14.6	8.86	5.03	3.64	2.88	2.32	1.52	1.22	0.624
1.70V	42.9	28.2	22.7	14.5	8.57	5.00	3.63	2.87	2.31	1.51	1.21	0.615
1.75V	39.9	28.0	22.0	14.3	8.45	4.92	3.61	2.86	2.30	1.50	1.20	0.600
1.80V	36.9	26.7	21.3	14.0	8.30	4.82	3.60	2.84	2.28	1.49	1.18	0.585
1.85V	33.9	25.3	20.6	13.8	8.16	4.80	3.58	2.82	2.27	1.48	1.17	0.570



UB12180

Maintenance-Free

Discharge Time vs. Discharge Current

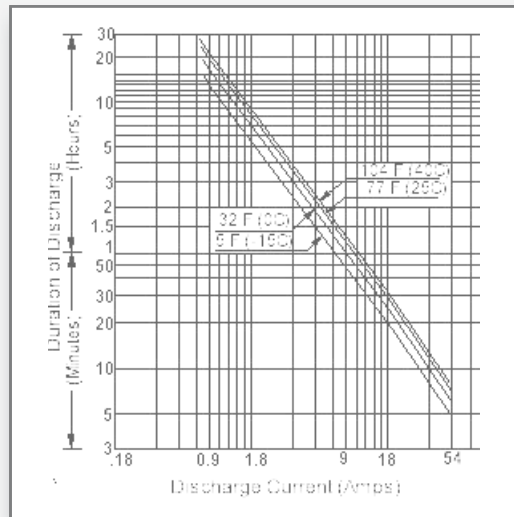

Discharge Characteristics

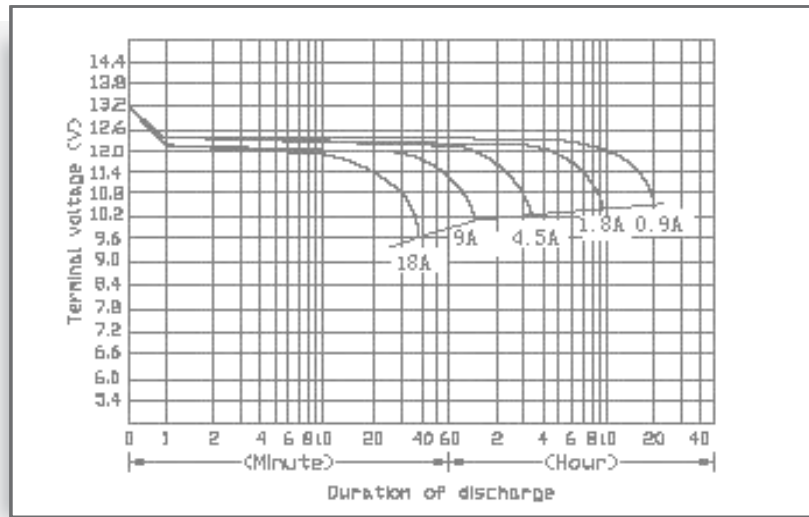

Shelf Life & Storage

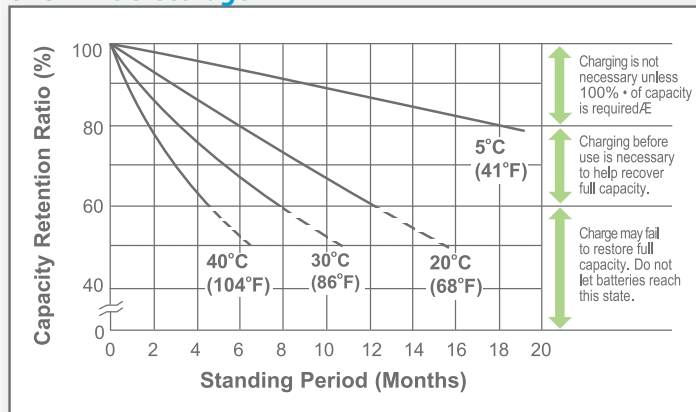

Cycle Life vs. Depth of Discharge

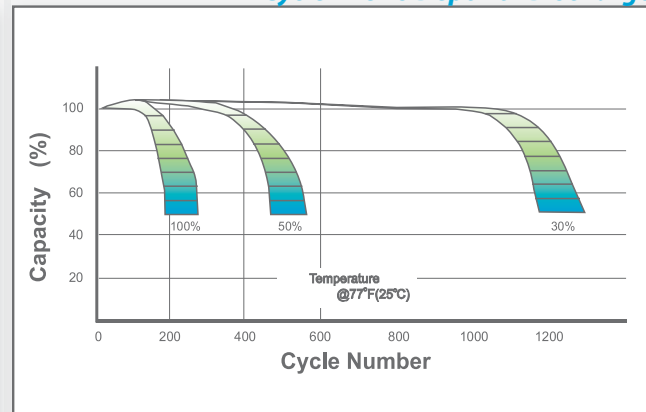

Open Circuit Voltage vs. Residual Capacity

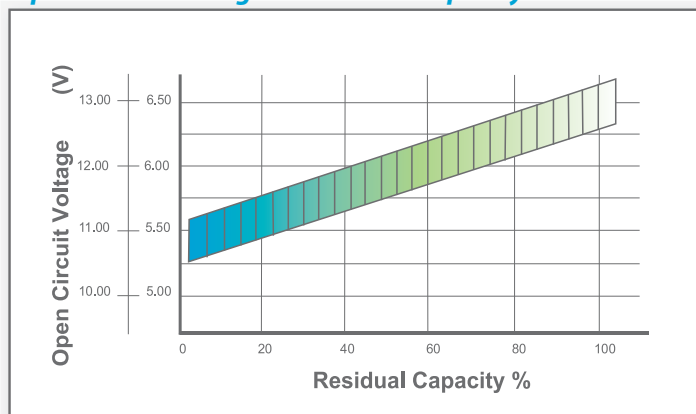

Effect of Temperature on Capacity

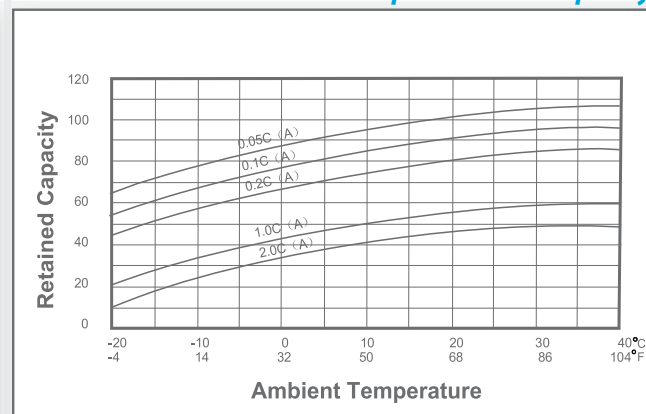

Charge Current & Final Discharge Voltage

Application	Charge Voltage(V/Cell)			Max. Charge Current	Final Discharge Voltage V/Cell	Discharge Current(A)	1.75	1.70	1.60	1.30
	Temperature	Set Point	Allowable Range							
Cycle Use	25°C(77°F)	2.45	2.40~2.50	0.35C	Discharge	0.2C>(A)	0.2C<(A)<0.5C	0.5C<(A)<1.0C	(A)>1.0C	
Standby	25°C(77°F)	2.325	2.30~2.35							



ISO 9001 :2008

Let UPG Power Your Life.

www.upgi.com

INTELLIGENT LOW PROFILE SENSORS

MIX-200 SERIES

Mircom's MIX-200 Series intelligent plug-in smoke detectors with integral communication provide features that surpass conventional detectors. Detector sensitivity is continuously monitored and reported to the FX-2000 Fire Alarm Control

Panel. Point ID capability allows each detector's address to be set with decade address switches, providing exact detector locations for selective maintenance when chamber contamination reaches an unacceptable level.



Intelligent Low Profile Ionization Smoke Sensor (MIX-1251B)

The Intelligent Ionization Smoke Sensor is constantly monitored to measure any change in its sensitivity due to the environment (dirt, aging, temperature, humidity, etc.) It can give an advance indication to the FX-2000 analog control panel of the need for maintenance and can be specific as to where the maintenance is needed. It can be mounted in a number of different bases. See the Ordering Information for a list of these bases and their descriptions.



Intelligent Low Profile Photoelectronic Smoke Sensor (MIX-2251B)

The Intelligent Photoelectronic Smoke Sensor is constantly monitored to measure any change in its sensitivity due to the environment (dirt, aging, temperature, humidity, etc.) It can give an advance indication to the FX-2000 analog control panel of the need for maintenance and can be specific as to where the maintenance is needed. It can be mounted in a number of different bases. See the Ordering Information for a list of these bases and their descriptions.



Intelligent Thermal Sensors (MIX-5251B/MIX-5251RB/MIX-5251H)

The Intelligent Thermal Sensors contain a dual thermistor sensing circuit for fast response. They provide open area protection with 50 foot spacing. The sensors rapid response characteristic virtually eliminates the thermal lag which is characteristic of conventional heat detectors and insures operation as soon as the temperature reaches its set point (MIX-5251B), or upon a temperature rise of 15°F per minute (MIX-5251RB). The MIX-5251H provides fixed high temperature detection at 190°F. These sensors can be mounted in a number of different bases. See the Ordering Information for a list of these bases and their descriptions.



Intelligent Low Profile Photoelectronic Smoke Sensor with Thermal (MIX-2251TB)

The MIX-2251TB has the same features as the MIX-2251B and includes a 135°F thermal sensor. It can be mounted in a number of different bases. See the Ordering Information for a list of these bases and their descriptions.



S6295
(MIX-1251B,
MIX-2251B &
MIX-2251TB)



S6965
(MIX-1251B,
MIX-2251B &
MIX-2251TB)



7271-1477:122
(MIX-1251B)
7271-1477:117
(MIX-2251B/TB)
7271-1477:114
(MIX-5251B/RB/H)



148-03-E
(MIX-1251B)
219-02-E
(MIX-2251B/TB)
390-02-E
(MIX-5251B/RB/H)



2151
(MIX-1251B)
2131
(MIX-2251B/TB)



APPROVED
3017996

Specifications

Height

2.0 inches (51 mm)

Diameter

6.1 inches (155 mm) Installed in B210LP Base

4.1 inches (104 mm) Installed in B501 Base

Shipping Weight

Heat: 4.8 oz. (137 g)

Photo/Photo with Heat: 5.2 oz. (147 g)

Ion: 5.4 oz. (154 g)

Operating Temperature Range

Ion/Photo: 32°F to 120°F (0°C to 49°C)

Photo with Thermal: 32°F to 100°F (0°C to 38°C)

Thermal: -4°F to 100°F (-20°C to 38°C)

High Temperature: -4°F to 100°F (-20°C to 66°C)

UL Listed Velocity Range

Ion: 0 - 1200 fpm (0 - 5.1 m/sec)

Photo/Photo with Thermal: 0 - 4000 fpm (0 - 20 m/sec)

Relative Humidity

10% - 93% noncondensing

Insect Screen Hole Size

Photo: 0.016 inch (0.41mm) nominal

Ion: 0.035 inch (0.89mm) nominal

Thermal Ratings

Fixed Temperature Setpoint: 135°F (57°C)

Rate of Rise Detection: 15°F/min. (8.3°C/min.)

High Temperature: 190°F (88°C)

Voltage Range

15 - 32 volts DC peak

Standby Current

Ion/Thermal:

150 μ A @ 24 VDC (without communication, LED off)

200 μ A @ 24 VDC (one communication every 5 sec. with LED enabled)

Photo/Photo with Thermal:

250 μ A @ 24 VDC (without communication, LED off)

300 μ A @ 24 VDC (one communication every 5 sec. with LED enabled)

LED Current (max.)

6.5 mA @ 24 VDC (on)

Note: Mounting sensors outside of the specified temperature ranges will cause sensor failures and erratic panel operation.

Ordering Information

Model

Description

Intelligent Addressable Analog Sensors

MIX-1251B Intelligent Low Profile Ionization Smoke Sensor

MIX-2251B Intelligent Low Profile Photoelectronic Smoke Sensor

MIX-2251TB Intelligent Low Profile Photoelectronic Smoke Sensor c/w 135°F Fixed Temp. Thermal Sensor

MIX-5251B Intelligent Low Profile Fixed Temp. Thermal Sensor 135°F

MIX-5251RB Intelligent Low Profile Fixed Temp. and Rate of Rise Thermal Sensor 135°F

MIX-5251H Intelligent Low Profile High Temperature Thermal Sensor 190°F

Intelligent Analog Bases

B210LP Intelligent Flanged Mounting Base

B224BI Intelligent Isolator Base

B224RB Intelligent Relay Base*

B501 Intelligent Flangeless Mounting Base

B501BH Intelligent Sounder Base

B501BHT Intelligent Temporal Tone Sounder Base

Accessories

RA-400Z Remote LED Annunciator

Note: For Canadian models add suffix "A".

* When used with the M500X Fault Isolator Module, the number of relay bases between fault isolators is limited to 12.

NOT TO BE USED FOR INSTALLATION PURPOSES.



Canada

25 Interchange Way
Vaughan, Ontario L4K 5W3
Telephone: (905) 660-4655
Fax: (905) 660-4113

U.S.A.

4575 Witmer Industrial Estates
Niagara Falls, NY 14305
Toll Free: (888) 660-4655
Fax Toll Free: (888) 660-4113

Web page: <http://www.mircom.com> Email: mail@mircom.com

Distributed by:

ISO 9001:2000
REGISTERED



CAT. 5904
Rev. 5

MOUNTING BASES

200 SERIES

Mircom's mounting bases and kits provide a variety of ways to install detectors in any application.

The MIX-200 Series detectors can be mounted in either flanged or flangeless bases depending on the junction box selection.



B501 Flangeless Mounting Base

The B501 is standard base with no flange.



B501BH Sounder Base

The B501BH Sounder Base provides a built-in sounder which can be used for evacuation purposes.



B210LP Flanged Mounting Base

The B210LP is a low profile mounting base with a flange.



B224RB Relay Base

The B224RB Relay Base provides one form C relay contact for control of auxiliary functions such as damper control and elevator recall.



B224BI Isolator Base

The B224BI Isolator Base allows loops to continue to operate under fault conditions and automatically restore when the fault is removed.



CATALOG NUMBER **5906**

NOT TO BE USED FOR INSTALLATION PURPOSES.

Mircom reserves the right to make changes at any time without notice in prices, colours, materials, components, equipment, specifications and models and also to discontinue models.

Specifications

Base Specifications

Diameter
4.0" (102 mm);flangeless
6.1" (155 mm);flange

Height
1.2" (31 mm)

Wire Gauge
12 - 22 AWG

Temperature Range
32°F to 120°F (0°C to 49°C)

Humidity Range
10% to 93% RH noncondensing

B224RB/B224BI Electrical Ratings

Operating Voltage
15 to 32 VDC

Standby Ratings
<500 µA maximum @24 VDC

Set Time
4 sec.minimum,20 sec.maximum

Reset Time
1 sec.minimum, 8 sec.maximum

Relay Characteristics (relay base only)
2 coil latching relay
1 Form C contact
Resistive contact rating: 2 A @ 30 VDC
Inductive contact rating:
0.3 A @ 110 VDC (with .35 pF or greater),
0.3 A @ 120 VAC (with .35 pF or greater),
1.0 A @ 30 VDC (with .6 pF or greater)

B501BH/B501BHT Electrical Ratings

External Supply Voltage
17 to 32 VDC

Standby Current
1.0 mA max.

Alarm Current
15 mA max.

Maximum Ripple Voltage
10% of supply voltage

Start-up Capacitance
200 µF

Sound Output
Greater than 90 dBA measured in anechoic room at 10 feet, 24 volts. 85 dBA minimum in UL reverberant room.

200 Series Junction Box Selection Guide

Model	Single Gang	3.5" Oct.	4" Oct.	4" Sq.	4" Sq.*	50 mm	60 mm	70 mm	75 mm
B501	No	Yes	No	No	Yes	Yes	Yes	Yes	No
B210LP	Yes	Yes	Yes	Yes	Yes	No	No	No	No
B224RB	No	Yes	Yes	Yes	No	No	Yes	Yes	Yes
B224BI	No	Yes	Yes	Yes	No	No	No	Yes	Yes
B501BH	No	No	No	Yes	No	No	No	No	No
B501BHT	No	No	No	Yes	No	No	No	No	No

*with 3.0 .mud ring

Note: Box depth contingent on base and wire size. Refer to National Electric Code or applicable local codes for appropriate recommendations.

Recessed Mounting Kit Product Overview

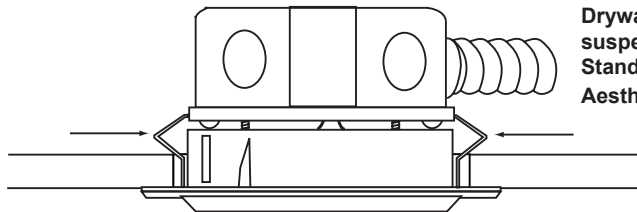

Drywall or suspended ceiling
Standard junction boxes
Aesthetically pleasing

Used with B501,the RMK400 provides a simple installation solution in applications that demand a lower profile smoke detector.

Uses. Kit is suitable for use with 4"octagon, 50mm, and 60mm junction boxes connected to flexible conduit.

Junction boxes are not included in kit.

Note: Not listed for use with MIX-1251(A).

Ordering Information

Model	Description	Agency Listing
B501	Flangeless Mounting Base	UL, ULC, FM, CSFM, MEA
B210LP	Flanged Mounting Base	UL, ULC, FM, CSFM, MEA
B501BH	Sounder Base	UL, ULC, CSFM, MEA, SSL
B501BHT	Temporal Tone Sounder Base	UL
B224RB	Relay Base	UL, ULC, CSFM, MEA
B224BI	Isolator Base	UL, ULC, CSFM, FM, MEA
RA400Z	Remote LED Annunciator	

Note: For Canadian models add suffix "A".

NOT TO BE USED FOR INSTALLATION PURPOSES.



Canada
25 Interchange Way
Vaughan, Ontario L4K 5W3
Telephone: (905) 660-4655
Fax: (905) 660-4113

U.S.A.
4575 Witmer Industrial Estates
Niagara Falls, NY 14305
Toll Free: (888) 660-4655
Fax Toll Free: (888) 660-4113

Web page: <http://www.mircom.com> Email: mail@mircom.com

Distributed by:



CAT. 5906
Rev. 4



Advanced Multi-Criteria Fire Detector with four unique sensing elements

This latest addition to the System Sensor 200 Series combines four complementary technologies into one device to convey accurate fire sensing information for locations where absolute certainty is required.

Features

- Unique ability to detect all four major elements of a fire
- Highest nuisance alarm immunity
- Advanced algorithms interpret and respond to the multiple inputs
- Six levels of sensitivity
- CO sensing for fastest response to slow-developing, smoldering fires
- Fully integrated infrared sensing to support the fire alarm decision
- Automatic drift compensation of smoke sensor and CO cell
- Superior EMI protection
- Twin LED indicators providing 360° visibility
- LEDs can be panel controlled to blink, latch on, latch off
- Built-in test switch



This plug-in fire detector combines four separate sensing elements in one unit: 1. photoelectric chamber senses airborne particulate for smoke detection, 2. electrochemical cell technology monitors carbon monoxide (CO) produced by smoldering fires, 3. infrared (IR) sensing measures ambient light levels and flame signatures, and 4. thermal detection monitors temperature.

The integration of continual monitoring for all four major elements of a fire has enabled System Sensor to create a detector that responds more quickly to an actual fire with the highest immunity to nuisances. This advanced multi-criteria detector normally operates at a high immunity level and changes to become very sensitive to fires as soon as fire characteristics are sensed. In this way, nuisances are monitored and ignored, reducing false alarms.

The detector's onboard intelligence runs advanced algorithms that dynamically adjust detection parameters to respond to the inputs from the sensors, enabling instant response as ambient conditions change. The program changes sensor thresholds, sensor gain, time, delays, combinations, sampling rates and averaging rates. If any sensor fails, the detector automatically adjusts the sensitivity of the remaining sensors. It also recognizes a fault condition.

The CO sensing cell has an expected lifetime of approximately six years. The CO cell is not a field-replaceable component. An internal timer signals the control panel to indicate the approach of the CO cell's end of life. Upon expiration, you should contact the system supplier to arrange for replacement of the unit. However, detection is not compromised when the CO cell is expired. The algorithms automatically adjust to properly weight the inputs from the photoelectric, heat and IR sensors.

The IR light sensor recognizes specific situations, such as welding, and makes adjustments rapidly to further reduce the potential for nuisance alarms. The thermal detection function fuses thermistor technology with a software-corrected, linear temperature response to offer exceptional nuisance alarm immunity and excellent fire detection.

Agency Listings



S911



CS308



3030459



7272-1653:0208



2203

NOTE: The CO cell is specifically deployed as a component of smoke detection in this device. This device is not listed for applications in which standalone CO detection is required for life safety.

2251-COPTIR Specifications

Physical Specifications

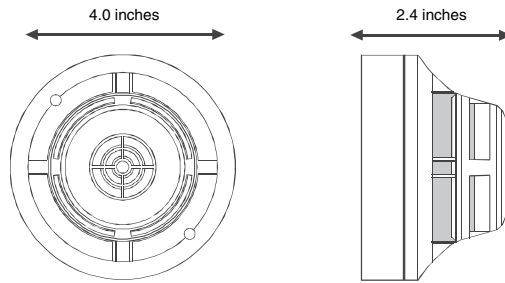

Height	2.7" installed in B210LP base or B501 base
Diameter	6.0" installed in B210LP base; 4.0" installed in B501 base
Shipping Weight	4.6 oz
Color	Ivory
Material	Bayblend FR110
Operating Humidity Range	10 to 93% relative humidity (non-condensing)
Application Temperature Range	32°F to 100°F (0°C to 38°C)
Air Velocity	0 to 4000 ft/min (0 to 20 m/sec)

Electrical Specifications

Operating Voltage Range	15 to 32 VDC
Maximum Standby Current	300 μ A at 24 VDC (one communication every 5 seconds with LED blink enabled)
Maximum Alarm Current (LED on)	7mA at 24 VDC

Sensitivity Settings and Suggested Applications

Level 1	1% / ft of smoke	Very clean environments – laboratories
Level 2	2% / ft of smoke	Clean environments – offices
Level 3	3% / ft of smoke	Moderately clean environments – hotel rooms, dorm rooms
Level 4	3% / ft of smoke with different algorithm processing and weighting of sensor elements	Hotel rooms near a shower, boiler rooms
Level 5	4% / ft of smoke	Equipment rooms, kitchens, paint shops
Level 6	Thermal alarm at 135°F (57°C)	
*Once the CO cell has reached the end of life and enters Photo, Thermal, Infrared (PTIR) mode, the following sensitivities apply:		
Level 1	1% / ft of smoke	Very clean environments – laboratories
Level 2	2% / ft of smoke	Clean environments – offices
Level 5	3% / ft of smoke	Moderately clean environments – hotel rooms, dorm rooms
Level 6	Thermal alarm at 135°F (57°C)	

Ordering Information

Part No.	Description		
2251-COPTIR(A)*	Advanced Multi-Criteria Fire Detector		
Bases		Accessories	
B501(A)	4" Flangeless Mounting Base	SMB600	Surface Mounting Kit (flanged)
B501BP(A)	4" Flangeless Mounting Base Bulk Pack	F110	Accessory Flange Ring for 6" Base
B210LP(A)	6" Flanged Mounting Base	F110BP	Accessory Flange Ring for 6" Base Bulk Pack
B210LPBP	6" Flanged Mounting Base Bulk Pack	F210	Accessory New Smaller Flange Ring for 6" Base
B200SR(A)	Standard Sounder Base (Compatible with B501BH Series)	RA100Z(A)	Remote LED Annunciator
B200S(A)	Intelligent Addressable Sounder Base	M02-04-01	Detector Test Magnet
B224RB(A)	Relay Base	M02-09-00	Telescoping Test Magnet
B224BI(A)	Isolator Base		

*(A) suffix denotes Canadian Product



3825 Ohio Avenue • St. Charles, IL 60174
 Phone: 800-SENSOR2 • Fax: 630-377-6495
 www.systemsensor.com

©2012 System Sensor.
 Product specifications subject to change without notice. Visit systemsensor.com
 for current product information, including the latest version of this data sheet.
 SPDS76301 • 1/12



MS-701ADU
Intelligent Addressable
Single Action Manual Station

MS-710ADU
Intelligent Addressable
Dual Action Manual Station

Description

Mircom's MS-700ADU Series provide manual fire reporting. These high quality, die-cast metal Intelligent Fire Alarm Manual Stations are available in either single or dual action configurations with a permanently attached addressable module.

The MS-700ADU Series stations are available as single or dual-action devices with key resets and a permanently attached addressable module. The addressable manual station has a pair of rotary decimal switches which allows for two digit address setting. Pulling the handle initiates the operation of the addressable module.

All models are available with CAT-30 keys and mount on a standard single gang backbox, Mircom model BB-700 interior surface metal backbox, or BB-700WP weather proof backbox.

Features

- Single or Dual Action
- Key resettable
- Permanently Attached Intelligent Addressable Module
- High-gloss red enamel finish
- Plastic breakrod
- Meets ADA 5 lb. maximum manual-force
- Mounts on standard single gang box, Mircom's BB-700 surface metal backbox or BB-700WP weather proof backbox

Operation

The MS-701ADU Single Action Intelligent Manual Station is operated by pulling down the handle marked "PULL HANDLE" on the front of the station. The MS-710U Dual Action Intelligent Manual Station is operated by pushing the bar labelled "PUSH BAR" and then pulling down the handle marked "PULL HANDLE". The MS-700ADU Series Manual Stations are reset by opening the station with the key, placing the handle in the normal upright position and re-locking the station.

Specifications

The manual station shall be Mircom's MS-700ADU Series. Operating instructions shall be in raised English lettering and the unit shall be constructed of high quality die-cast metal and finished in red enamel paint to provide quick identification. Pulling the handle shall initiate immediate operation of the intelligent addressable module. All manual fire alarm stations shall be installed as per the specific requirements outlined in the UL codes, as well as all other applicable national or local codes. Final acceptance is subject to the local authority having jurisdiction.



S7005

S7005

7150-1477:128

Specifications

Switch Rating:	1 Amp @ 30 VDC 0.1 Amp @ 125 VAC
Manual Station Dimensions:	4.9" H x 3.5" W x 2.0" D
Color:	Red with raised white letters, white Manual bar with raised red letters.
Current Consumption:	Standby: 400 μ A Alarm: 5.5 mA

Surface Mount Backboxes



BB-700 Surface Mount Backbox

Dimensions:
5" H x 3.6" W x 2.0" D



BB-700WP Weatherproof Surface Mount Backbox

Dimensions:
5" H x 3.6" W x 2.2" D

Typical Wiring Diagram

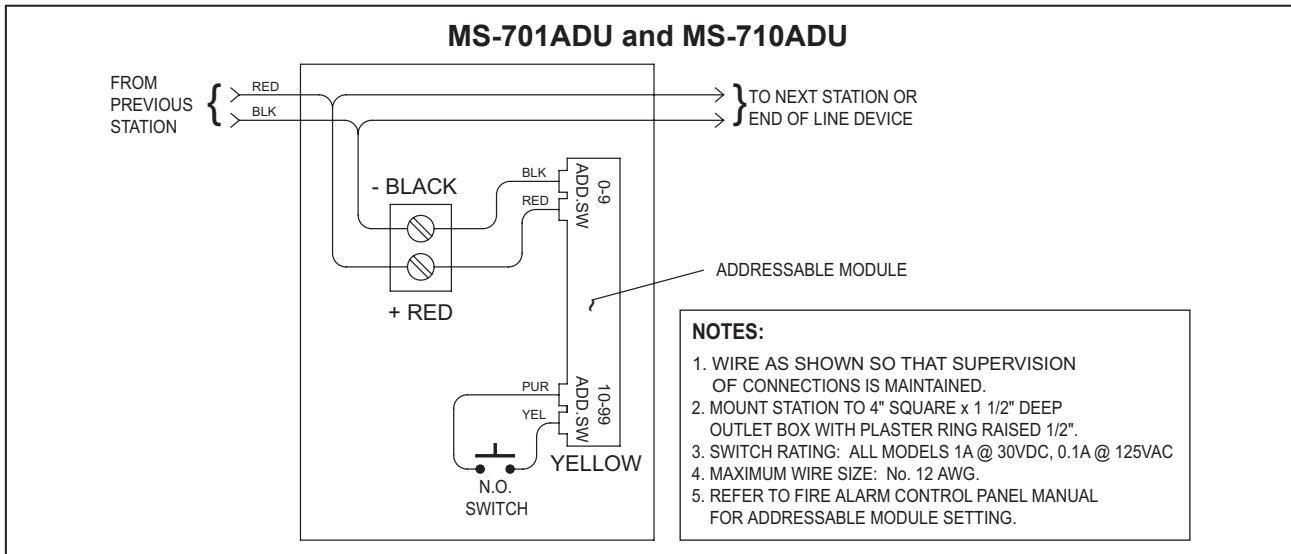

Ordering Information

Model	Description
MS-701ADU	Intelligent Addressable Key Resettable Single Action Manual Station
MS-702ADU	Intelligent Addressable Key Resettable Dual Stage Single Action Manual Station
MS-710ADU	Intelligent Addressable Key Resettable Dual Action Manual Station
BB-700	Series 700 Interior Surface Mount Backbox, Red Finish
BB-700WP	Series 700 Weatherproof Surface Mount Backbox, Red Finish

Add suffix "NY" for New York Versions

NOT TO BE USED FOR INSTALLATION PURPOSES.



Canada
25 Interchange Way
Vaughan, Ontario L4K 5W3
Telephone: (905) 660-4655
Fax: (905) 660-4113

U.S.A.
4575 Witmer Industrial Estates
Niagara Falls, NY 14305
Toll Free: (888) 660-4655
Fax Toll Free: (888) 660-4113

Web page: <http://www.mircom.com> Email: mail@mircom.com

ISO 9001:2000
REGISTERED

CAT. 5928
Rev. 2

Distributed by:



Description

Mircom's intelligent module products are designed to meet a wide range of applications. Monitor and control modules can be used to supervise and activate sounders, strobes, door closers, pull stations, waterflow switches, conventional smoke detectors, and more. Each module is rigorously designed and tested for electromagnetic compatibility and environmental reliability, in many cases exceeding industry standards. Modules are addressed with easy-to-use rotary code switches. Full size modules mount in standard 4" x 4" x 2 1/8" junction box. Wiring terminals are easily accessible for troubleshooting purposes.

MIX-M500M Monitor Module, MIX-M501M Mini Monitor Module and MIX-M500DM Dual Input Monitor Module

Mircom's monitor modules provide an interface to contact devices, such as security contacts, waterflow switches, or manual stations. They are capable of Styles A and B supervised wiring to the load device (MIX-M500M is capable of Style D). Conventional 4-wire smoke detectors can be monitored through their alarm and trouble contacts, wired as an initiating loop to the module. In addition to transmitting the supervised state of the monitored device (normal, open, or short), the full analog supervision measurement is sent back to the panel. This allows impedance changes in the supervised loop to the monitored device to be detected.

The MIX-M500DM is capable of monitoring two separate Class B circuits simultaneously, making it ideal for waterflow tamper switch and flow switch monitoring. The small size of the MIX-M501M allows it to fit inside devices or junction boxes behind devices.

MIX-M500R Relay Module

The MIX-M500R Relay Module contains two isolated sets of Form-C contacts, which operate as a DPDT switch. The module allows the control panel to switch these contacts on command. No supervision is provided for the relay contacts.

Features

- Designed to meet a wide range of applications
- SEMS screws for easy wiring
- Panel controlled status LED (except MIX-M501M)
- Analog communications
- Rotary address switches (except MIX-M500X)
- Low standby current
- Mounts in 4" square junction box

MIX-M502M Zone Interface Module

The MIX-M502M Zone Interface Module allows Mircom's intelligent panels to interface and monitor two-wire conventional smoke detectors. All two-wire detectors being monitored must be UL or ULC compatible with the module. The MIX-M502M is addressed through the communication line of an intelligent Mircom system. It transmits the status of one zone of two-wire detectors to the fire alarm control panel. Status conditions are reported as normal, open, or alarm. The interface module supervises the zone of detectors and the connection of the external power supply.

MIX-M500S Supervised Control Module

The MIX-M500S Supervised Control Module provides supervised monitoring of wiring to load devices that require an external power supply to operate, such as horns, strobes, or bells. It is capable of Styles Y and Z supervision. Upon command from the control panel, the MIX-M500S will disconnect the supervision and connect the external power supply across the load device. The disconnection of the supervision provides a positive indication to the panel that the control relay actually turned on. The external power supply is always relay isolated from the communication loop, so that a trouble condition on the power supply will never interfere with the rest of the system. Full analog measurement of the supervised wiring is transmitted back to the panel and can be used to detect impedance changes or other special test functions.



S5434



S5434



7300-1477:113
(MIX-M501M, MIX-500R,
MIX-500S & MIX-M502M)
7300-1477:126
(MIX-M500DM)
7300-1477:127
(MIX-M500M)

MEA
approved

427-91-E
(MIX-M500, MIX-M501M)
87-01-E
(MIX-M500R, MIX-M500S)
227-03-E
(MIX-M500DM)



APPROVED
3017996

CATALOG NUMBER **5903**

NOT TO BE USED FOR INSTALLATION PURPOSES.

M500X Isolator Module

The M500X Isolator Module is an automatic switch that opens when the line voltage drops below four volts. Isolator modules should be spaced between groups of sensors or modules in a loop to protect the rest of the loop. If a short occurs between any two isolators, then both

isolators immediately switch to an open circuit state and isolate the devices between them. The remaining units on the loop continue to fully operate. No more than 25 devices are recommended for each group.

Specifications

General Specifications

Operating Voltage	
15-32 VDC	
Communication Line Loop Impedance	
40 Ω max.	
Temperature Range	
32° to 120°F (0° to 49°C)	
Relative Humidity	
10% to 93%: noncondensing	
Dimensions	
MIX-M501M	2.7"W x 1.7"H x 0.5"D
Others:	4.25"W x 4.65"H x 1.1"D
Shipping Weight	
M501M: 1.2 oz (37g)	Others: 6.3 oz (196g)

MIX-M500M, MIX-M500S, MIX-M501M Specifications

Standby Current
400 µA max @ 24 VDC (one communication every 5 sec. with 47k EOL) 550 µA max @ 24 VDC (one communication every 5 sec. with EOL<1k) 5.5 mA (with LED latched on)
End-of-Line Resistance
47 kΩ (included)

MIX-M500R Specifications

Standby Current
300 µA @ 24 VDC (one communication every 5 sec. with LED enabled)
LED Current
5.5 mA (with LED latched on)
Relay Contact Ratings
3.0 A @ 30 VDC resistive 0.9 A @ 110 VDC resistive 0.9 A @ 125 VAC resistive 0.5 A @ 125 VAC inductive (PF=.35) 0.7 A @ 75 VAC inductive (PF=.35)

MIX-M502M Specifications

Standby Current
300 µA max @ 24 VDC (one communication every 5 sec. with LED enabled)
External Power Supply
18-28 VDC (100 mV ripple max.)
End-of-Line Resistance
3.9 kΩ (included)
External Supply Standby Current
11.5 mA @ 24 VDC (nominal)
External Supply Alarm Current
80 mA @ 24 VDC (nominal)

MIX-M500DM Specifications

Standby Current
750 µA max. @ 24 VDC (one communication every 5 sec. with 47k EOL)
Alarm Current
970 µA max. (one communication every 5 sec.) 6 mA (with LED latched on)
End-of-Line Resistance
47 kΩ (two included)

MIX-M500X Specifications

Standby Current
450 µA max
Isolation Current
5 mA max
Fault Detection Delay
250 ms min.
Fault Detection Threshold
4 Volts
Line Restoration Threshold
7 Volts

Ordering Information

Model	Description
MIX-M500M	Monitor Module
MIX-M500R	Relay Module
MIX-M500S	Supervised Control Module
MIX-M501M	Mini Monitor Module
MIX-M502M	Zone Interface Module
MIX-M500X	Isolator Module
MIX-M500DM	Dual Input Monitor Module

Add suffix "A" for Canadian model.

NOT TO BE USED FOR INSTALLATION PURPOSES.



Canada

25 Interchange Way
Vaughan, Ontario L4K 5W3
Telephone: (905) 660-4655
Fax: (905) 660-4113

U.S.A.

4575 Witmer Industrial Estates
Niagara Falls, NY 14305
Toll Free: (888) 660-4655
Fax Toll Free: (888) 660-4113

Web page: <http://www.mircom.com> Email: mail@mircom.com

Distributed by:

ISO 9001:2008
REGISTERED



CAT. 5903
Rev. 6



You in Control

MR-199 SERIES

HEAVY DUTY POWER RELAYS

PRODUCT DESCRIPTION

The MR-199 Series Heavy Duty Power Relays are designed for control applications where 30A DPDT contacts are required. Two models are available: the **MR-199X-13**, a 24VDC coil, and the **MR-199X-14**, a 120VAC coil. Both models may be ordered in a rugged steel enclosure.



MR-199X-13 or
MR-199X-14



MR-199X-13/C (-14)
(or MR-199X-13/C/R (-14) with red enclosure)

WIRING

MR-199 Series

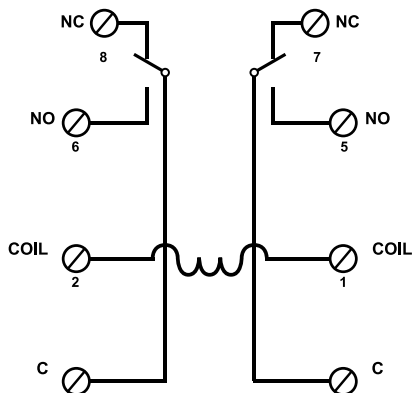

CSFM LISTED

MEA APPROVED

Air Products and Controls is
a Brand of Apollo America
25 Corporate Drive
Auburn Hills, MI 48326
(248) 332-3900 Phone
(888) 332-2241 Toll free
(248) 332-8807 Fax
www.ap-c.com

A
HALMA
GROUP
COMPANY

Distributed By:



PRODUCT SPECIFICATIONS

MODEL NUMBER	INPUT VOLTAGE	MODULE POSITIONS	CONTACT CONFIGURATION PER POSITION	RELAY ONLY H X W X D	ENCLOSURE MOUNTED H X W X D	COVER MATERIAL	UL* FILE S3403
MR-199X-13	24VDC	1	DPDT	3.33" (84mm) 2.50" (63mm) 2.18" (55mm)			UOXX2
MR-199X-14	120VAC						
MR-199X-13/C	24VDC	1	DPDT		5.35" (136mm) 3.41" (86mm) 3.04" (77mm)	Grey 18ga CRS	UOXX UOXX2 UUKL UUKL2
MR-199X-14/C	120VAC						
MR-199X-13/C/R	24VDC	1	DPDT		5.35" (136mm) 3.41" (86mm) 3.04" (77mm)	Red 18ga CRS	UOXX UOXX2 UUKL UUKL2
MR-199X-14/C/R	120VAC						

POWER REQUIREMENTS:		MR-199X-13	24VDC @ 85mA, Minimum pull-in voltage: 75% of nominal voltage @ 25°C
		MR-199X-14	120VAC @ 85mA, Minimum pull-in voltage: 85% of nominal voltage @ 25°C
COIL DATA:	Nominal	DC coils (-13)	2.0 Watts @ 25°C
		AC coils (-14)	9.8VA @ 25°C
	Max	DC coils (-13)	8.0 Watts @ 25°C
COMPONENTS:		UL Recognized as component; UL Listed when installed in enclosure (/C versions)	
POLARIZED:		No	
CONTACT RATINGS:		30A @ 240VAC; 20A @ 277VAC; 2HP @ 240VAC / 1.5HP @ 120VAC	
CONTACT CONSTRUCTION:		Dry form "C" DPDT	
ENVIRONMENTAL:		32°F to 120°F (0°C to 49°C) @ 85% RH (@ 32°F), Non-condensing, Non-freezing	
WIRING:		#6 to #14 AWG terminals	
/C VERSIONS:		Backbox: 18ga CRS, plated with 1/2" conduit knockouts top and bottom	

*UOXX = Control Unit Accessories, System; 2 = Component
 UUKL = Smoke Control System Equipment
 UUKL2 = Control System Equipment, Smoke

POWER LIMITED WIRING

MR-199X-13
MR-199X-13/C
MR-199X-13/C/R
 COIL POWER: 24VDC

SIDE VIEW - OTHER SIDE IDENTICAL

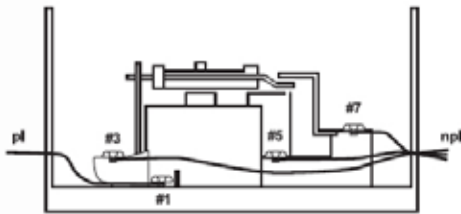

*pl - POWER LIMITED
 *npl - NON-POWER LIMITED

TOP VIEW

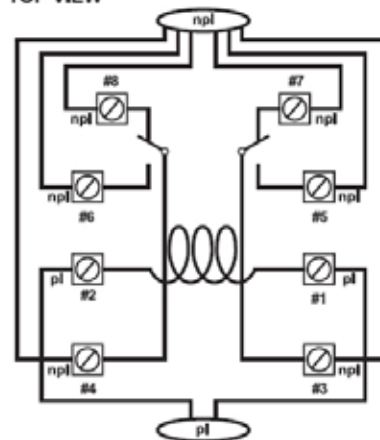

CAUTION: MINIMUM 1/4" SEGREGATION BETWEEN POWER LIMITED AND NON-POWER LIMITED WIRING
CAUTION: DE-ENERGIZE POWER BEFORE SERVICE
CAUTION: NON-ENCLOSED VERSIONS MUST BE MOUNTED IN THE APPLICATION ENCLOSURE

NOTICE: The information contained in this document is intended only as a summary and is subject to change without notice. The products described have specific instructional/installation documentation, which covers various technical, approval, code, limitation and liability information. Copies of this documentation along with any general product warning and limitation documents, which also contain important information, are provided with the product and are also available from Air Products and Controls Inc. The information contained in all of these documents should be considered before specifying or using the products. Any example applications shown are subject to the most current enforced local/national codes, standards, approvals, certifications, and/or the authority having jurisdiction. All of these resources, as well as the specific manufacturer of any shown or mentioned related equipment, should be consulted prior to any implementation. For further information or assistance concerning the products, contact Air Products and Controls Inc. Air Products and Controls Inc. reserves the right to change any and all documentation without notice.



Features

- RealTest[®] enables a functional test using canned CO
- Full compliance with UL 2075
- A code-required trouble relay
- Wiring supervision with SEMS terminals
- A six-year end-of-life timer
- 12/24 VDC
- A low current draw of 20 mA in standby and 40 mA in alarm
- Versatile mounting for wall and ceiling
- Accurate and reliable electrochemical sensing technology
- Optional CO-PLATE CO Detector Replacement Plate to upgrade previously installed competitor detectors to the CO1224T

Description

The System Sensor CO1224T and CO1224TR (round) Carbon Monoxide (CO) Detectors use a highly accurate and reliable electrochemical sensing cell to provide early warning of dangerous CO levels.

With RealTest[®] technology, the CO gas sensing cell used in the CO1224T and CO1224TR CO detectors can be tested using a CO gas agent, fully meeting the requirements of NFPA 720: 2009. Simply put the detector into RealTest mode, spray a small amount of CO into the detector per the installation instructions, and within seconds the detector will alarm, indicating successful gas entry. (See the reverse page or the user manual for complete instructions.)

When dangerous amounts of CO are detected, the CO1224T and CO1224TR detectors alert residents by sounding and flashing a temp 4 signal alarm. With 24/7 central station monitoring, residents are guaranteed protection whether they are away from home, sleeping, or already suffering from the effects of CO.

The CO1224T and CO1224TR are designed for system operation. These detectors are fully listed to UL 2075 and offer a code-required trouble relay to send a sensor failure or end-of-life signal to the control panel and the central station. The CO1224T and CO1224TR also use SEMS-type terminal Philips head screws for quicker and more positive wiring connections and code-required wiring supervision.

With a low current draw, these detectors enable more devices to be connected to the panel, limiting the need to purchase extra power supplies or more expensive panels. As 12/24 VDC detectors, the CO1224T and CO1224TR will operate on most industry security and fire alarm control panels.

Architectural/Engineering Specifications

Carbon monoxide detector shall be a System Sensor model number CO1224T or CO1224TR listed to Underwriters Laboratories UL 2075 for Gas and Vapor Detectors and Sensors. The detector shall be equipped with a sounder and a trouble relay. The detector's base shall be able to mount to a single-gang electrical box or direct (surface) mount to the wall or ceiling. Wiring connections shall be made by means of SEMS screws. The detector shall provide dual color LED indication that blinks to indicate normal standby, alarm, or end-of-life. When the sensor supervision is in a trouble condition, the detector shall send a trouble signal to the panel. When the detector gives a trouble or end-of-life signal, the detector shall be replaced. The detector shall provide a means to test CO gas entry into the CO sensing cell. The detector shall provide this with a test mode that accepts CO gas from a test agent and alarms immediately upon sensing CO entry.



Electrical Specifications		
Operating Voltage	12/24 VDC	
Audible Signal	85 dB in alarm	
Standby Current	20 mA	
Alarm Current	40 mA (75 mA test)	
Alarm Contact Ratings	0.5 A @ 30 VDC	
Trouble Contact Ratings	0.5 A @ 30 VDC	
Physical Specifications		
Size	CO1224T	Length: 5.1", Width: 3.3", Height: 1.3"
	CO1224TR	Diameter: 6", Height: 1.3"
Approximate Weight	CO1224T: 7 oz; CO1224TR: 11 oz	
Operating Temperature Range	32° – 104° F (0° – 40° C)	
Operating Humidity Range	22 – 90% RH	
Input Terminals	14 – 22 AWG	
Mounting	Single-gang back box; surface mount to wall or ceiling	

Operation Modes

Operation Mode	Green LED	Red LED	Sounder
Normal (standby)	Blink 1 per minute	—	—
Alarm	—	Blink in temp 4 pattern	Sound in temp 4 pattern

RealTest® Feature: The System Sensor CO1224T and CO1224TR Carbon Monoxide Detectors with RealTest enable evaluation of the functionality of the CO sensing cell using a canned CO test agent.



1. Push and hold the Test/Hush button for two seconds to enter RealTest mode. The green LED will flash once every second to indicate RealTest mode has started.

2. Spray canned CO agent into the detector.

3. Verify CO sensing at the control panel. The detector will automatically exit RealTest alarm mode after about 20-60 seconds.

NOTE: Check with local codes and the AHJ to determine whether or not a functional gas test is desired for an installation.

Hush Feature: Pushing the Test/Hush button will silence the sounder for 5 minutes (except in RealTest mode).

Trouble Feature: When the detector is in a trouble condition, it will send a trouble signal to the panel.

End-of-life Timer: After the detector's internal sensor has reached the end of its life, a trouble signal will be sent to the panel. This will indicate that it is time to replace the detector. An electrochemical carbon monoxide detector lifespan is approximately six years, and the detector must be replaced by the date marked on the inside of the product.

CO-PLATE: System Sensor also offers the CO-PLATE CO Detector Replacement Plate to cover the footprint (when necessary) of previously installed competitive carbon monoxide detectors that require replacement.



CO-PLATE

Ordering Information

Model	Description
CO1224T	12/24 volt, 4-wire system-monitored carbon monoxide detector with RealTest® Technology
CO1224TR	12/24 volt, 4-wire system-monitored round carbon monoxide detector with RealTest® Technology
CO-PLATE	CO detector replacement plate to cover the footprint of previously installed competitive detectors as necessary

NOT TO BE USED FOR INSTALLATION PURPOSES.



Canada

25 Interchange Way
Vaughan, Ontario L4K 5W3
Telephone: (905) 660-4655
Fax: (905) 660-4113

U.S.A.

4575 Witmer Industrial Estates
Niagara Falls, NY 14305
Toll Free: (888) 660-4655
Fax Toll Free: (888) 660-4113

Web page: <http://www.mircom.com> Email: mail@mircom.com

Distributed by:





ESL DH Series

Electromagnetic Fire Door Holders

Overview

The DH Series Electromagnetic Fire Door Holders are constructed of the finest materials available. Each wall mount door holder is made of durable die-cast metal and finished in a high luster double chrome or brass plating for a high quality appearance.

For wall mount units, standard dual voltage AC or DC inputs reduce stocking requirements with 12/24V and 24/120V models. The 24/120V model draws a mere 15mA @ 24VAC or DC, helping keep overall job costs to a minimum.

Installation is easy with the ESL DH Series installation technique— an adhesive template assures alignment without secondary adjustments. No brackets are required for recessed, flush or surface mounting (the surface mounting box has three conduit ready entries). Plus, the new catch plate features two pivot points and two way adjustability to further ensure perfect alignment. Optional extension rods are also available for providing the proper gap distance between the door and wall. (Recess mounted door holder includes a 3" extension rod).

The basic units offer superiority reliability with built-in transient protection and low residual magnetism so they release easily even on new ADA low pressure door closers.



ESL Door Holders Wall & Floor Mount (insert)

Standard Features

- **Extremely low current draw. Only 15mA @ 24V saves on power supplies and backup batteries**
- **New recessed mount for lowest profile look**
- **Dual voltage inputs in each unit reduces stocking requirements**
- **Self-adjusting swivel catch-plate reduces installation time and adjusts to door alignment changes**
- **Optional extension rods make installation even faster**
- **Low residual magnetism easily releases even on new ADA low pressure door closers**
- **Built-in transient protection**
- **Floor mount units available, both single and double-coil**

DH Series

Electromagnetic Fire Door Holders

Surface Mount Back Box Dimensions

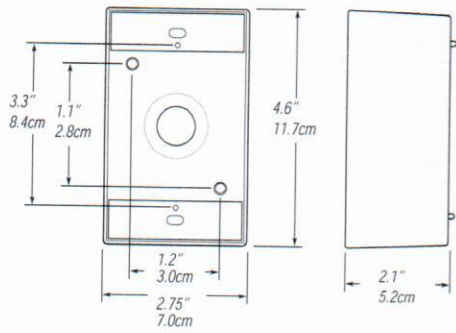

Door Magnet

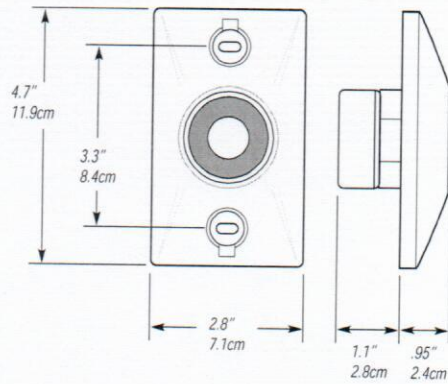

Extension Rod Applications and Accessories

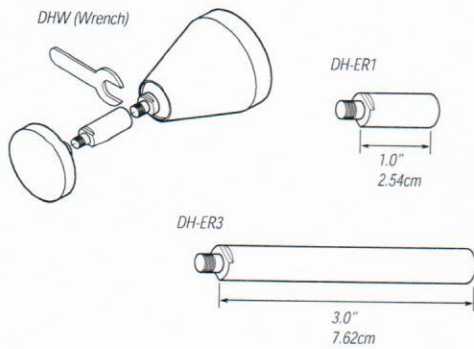

Catch Plate Assembly

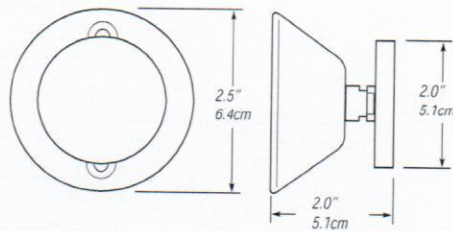

DH Series

Electromagnetic Fire Door Holders

DHS-24120C

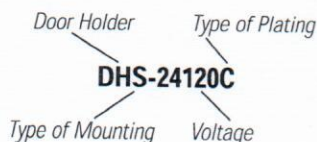

DHFM1-24120

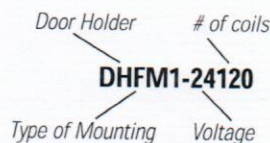

Ordering Information

Model	Description	Case Qty.
Wall Mount		
DHR-1224C	ESL 12 or 24 VDC/VAC, recess-mount, chrome, with 3" Extension Rod	20/case
DHR-24120C	ESL 24 VDC/VAC 120VAC, recess-mount, chrome, with 3" Extension Rod	20/case
DHF-1224C	ESL 12 or 24 VDC/VAC, semi-flush-mount, chrome	20/case
DHF-1224B	ESL 12 or 24 VDC/VAC, semi-flush-mount, brass	20/case
DHF-24120C	ESL 24 VDC/VAC 120VAC, recess-mount, chrome	20/case
DHF-2410B	ESL 24 VDC/VAC 120VAC, semi-flush-mount, brass	20/case
DHS-1224C	ESL 12 or 24VDC/VAC, surface-mount, chrome	20/case
DHS-1224B	ESL 12 or 24VDC/VAC, surface-mount, brass	20/case
DHS-24120C	ESL 24VDC/VAC 120VAC, surface-mount, chrome	20/case
DHS-24120B	ESL 24VDC/VAC 120VAC, surface-mount, brass	20/case
Floor Mount		
DHFM1-1224	Single coil, 12 or 24VDC/VAC, floor-mount, brushed steel, UL only, CUL pending	6/case
DHFM1-24120	Single coil, 24VDC/VAC 120VAC, floor-mount, brushed steel, UL only, CUL pending	6/case
DHFM2-1224	Double coil, 12 or 24VDC/VAC, floor-mount, brushed steel, UL only, CUL pending	6/case
DHFM2-24120	Double coil, 24VDC/VAC 120VAC, floor-mount, brushed steel, UL only, CUL pending	6/case
Extension Rods		
DH-ER1C	1" chrome	
DH-ER1B	1" brass	
DH-ER3C	3" chrome	
DH-ER3B	3" brass	
Accessories		
DHW	Extension rod wrenches	
DH-BP	Back Plate (chrome or brass)	
DH-ARMC	Replacement armature, chrome	
DH-ARMB	Replacement armature, brass	



GE Interlogix

www.GE-InterlogixSecurity.com

12345 SW Leveton Drive
Tualatin, OR 97062

Phone: 503-692-4052

USA & Canada: 800-547-2556

Technical Service: 800-648-7424

Faxback: 800-483-2495

2266 Second Street North
North St. Paul, MN 55109

Phone: 651-777-2690

USA & Canada: 800-777-5485

Technical Service: 800-777-2624

DH Series

Electromagnetic Fire Door Holders

Dual Voltage Terminal Diagram for Flush Mount, Recessed or Surface Mount

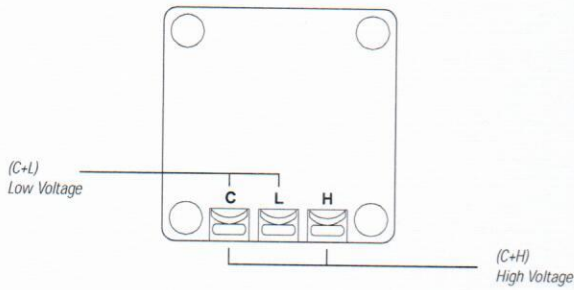

Dual Voltage Terminal Diagram for Floor Mount

Voltage References
 C = common
 L = low
 H = high

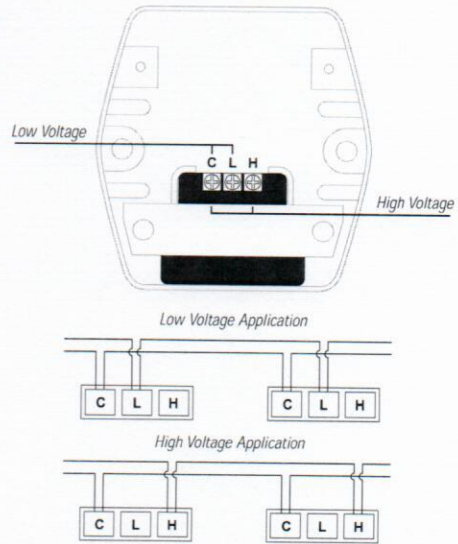

Performance Data

Model	Voltage	DC/mA	AC/mA	Terminals	Coil	lbs	kg. (Nominal)
DHX*-1224	12V	30	30	C&L	Single	35	15.9
	24V	15	15	C&H	Single	35	15.9
DHX*-24120	24V	15	15	C&L	Single	35	15.9
	120V	-	15	C&H	Single	35	15.9
DHFM [†] -1224	12V	60	60	C&L	Double	35	15.9
	24V	60	60	C&H	Double	35	15.9
DHFM [†] -24120	24V	30	30	C&L	Double	35	15.9
	120V	-	30	C&H	Double	35	15.9

* For all models, "X" represents either F (Flush Mount), FM (Floor Mount single-coil), R (Recessed), or S (Surface Mount).

† For Floor Mount, double coil models.

NOTE: Voltage supplied by a UL listed control panel



Outdoor Selectable-Output Horns, Strobes, and Horn Strobes for Wall Applications



SpectrAlert® Advance outdoor audible visible products are rich with features that cut installation times and maximize profits.

Features

- Weatherproof per NEMA 4X, IP56
- Listed to UL 1638 (strobe) and UL 464 (horn)
- Compatible with System Sensor synchronization protocol and legacy SpectrAlert products
- Field-selectable candela settings: 15, 15/75, 30, 75, 95, 110, 115, 135, 150, 177, and 185
- Automatic selection of 12- or 24-volt operation at 15 and 15/75 candela
- Rotary switch for horn tone and three volume selections
- Horn rated at 88+ dBA at 16 volts
- Rated from -40°F to 151°F
- Universal mounting plate with an onboard shorting spring that tests wiring continuity before devices are installed
- Plug-in design with minimal intrusion into the back box
- Tamper-resistant construction
- Listed for ceiling or wall mounting

SpectrAlert Advance offers the broadest line of outdoor horns, strobes, and horn strobes in the industry. With white or red plastic housings, wall or ceiling mounting options, and plain or FIRE-printed devices, SpectrAlert Advance can meet virtually any application requirement, including indoor, outdoor, wet, and dry applications in temperatures from -40°F to 151°F.

Like the entire SpectrAlert Advance line, outdoor horns, strobes, and horn strobes for wall applications include a variety of features that increase application flexibility and simplify installation. First, field-selectable settings, including candela, automatic selection of 12- or 24-volt operation, horn tones, and three volume options enable installers to easily adapt devices to meet requirements.

Next, SpectrAlert Advance devices use a universal mounting plate for both wall and ceiling applications. This mounting plate includes an onboard shorting spring that ensures wiring continuity before devices are installed, so installers can verify proper wiring without mounting the devices and exposing them to potential construction damage. Once the plates are mounted, all SpectrAlert Advance devices utilize a plug-in design with a single captured screw to speed installation and virtually eliminate costly ground faults.

Outdoor devices ship with weatherproof plastic back boxes (metal back boxes are available separately) that accommodate in-and-out wiring for daisy chaining devices. Plastic back boxes feature removable side flanges and improved resistance to saltwater corrosion. Knock-outs located on the back eliminate the need to drill holes for screw-in mounting. Plastic and metal weatherproof back boxes come with 3/4-inch top and bottom conduit entries and 3/4-inch knock-outs at the back. A screw-in NPT plug with an O-ring gasket for a watertight seal is included with each back box.

Agency Listings



S4011 (chimes, horn strobes, horns)
S3593 (outdoor and alert strobes)



3023572



MEA452-05-E



7300-1653-187 (outdoor strobes)
7125-1653-188 (horn strobes,
chime strobes)
7135-1653-189 (horns, chimes)

SpectrAlert Advance Outdoor Horn, Strobe, and Horn Strobe Specifications

Architect/Engineer Specifications

General

SpectrAlert Advance outdoor horns, strobes, and horn strobes shall mount to a weatherproof back box. A universal mounting plate shall be used for mounting ceiling and wall products. The notification appliance circuit wiring shall terminate at the universal mounting plate. Also, SpectrAlert Advance products, when used with the Sync•Circuit™ Module accessory, shall be powered from a non-coded notification appliance circuit output and shall operate on a nominal 12 or 24 volts. When used with the Sync•Circuit Module, 12-volt-rated notification appliance circuit outputs shall operate between 9 and 17.5 volts; 24-volt-rated notification appliance circuit outputs shall operate between 17 and 33 volts. Outdoor SpectrAlert Advance products shall operate between –40 and 151 degrees Fahrenheit from a regulated DC or full-wave rectified unfiltered power supply. Strobes and horn strobes shall have field-selectable candela settings including 15, 15/75, 30, 75, 95, 110, 115, 135, 150, 177, and 185.

Strobe

The strobe shall be a System Sensor SpectrAlert Advance Model _____ listed to UL 1971 and shall be approved for fire protective service. The strobe shall be wired as a primary-signaling notification appliance and comply with the Americans with Disabilities Act requirements for visible signaling appliances, flashing at 1 Hz over the strobe's entire operating voltage range. The strobe light shall consist of a xenon flash tube and associated lens/reflector system. The strobe must be installed with its weatherproof back box in order to remain outdoor approved per UL. The strobe shall be suitable for use in wet environments.

Horn Strobe Combination

The horn strobe shall be a System Sensor SpectrAlert Advance Model _____ listed to UL 1971 and UL 464 and shall be approved for fire protective service. The horn strobe shall be wired as a primary-signaling notification appliance and comply with the Americans with Disabilities Act requirements for visible signaling appliances, flashing at 1 Hz over the strobe's entire operating voltage range. The strobe light shall consist of a xenon flash tube and associated lens/reflector system. The horn shall have three audibility options and an option to switch between a temporal three pattern and a non-temporal (continuous) pattern. These options shall be set by a multiple position switch. On four-wire products, the strobe shall be powered independently of the sounder. The horn or horn strobe models shall operate on a coded or non-coded power supply. The horn strobe must be installed with its weatherproof back box in order to remain outdoor approved per UL. The horn strobe shall be suitable for use in wet environments.

Physical/Electrical Specifications

Operating Temperature	–40°F to 151°F (–40°C to 66°C)
Strobe Flash Rate	1 flash per second
Nominal Voltage	Regulated 12 DC/FWR or regulated 24 DC/FWR ¹
Operating Voltage Range²	8 to 17.5 V (12 V nominal) or 16 to 33 V (24 V nominal)
Input Terminal Wire Gauge	12 to 18 AWG
Wall-Mount Dimensions (including lens)	5.6" L × 4.7" W × 2.5" D (142 mm L × 119 mm W × 64 mm D)
Horn Dimensions	5.6" L × 4.7" W × 1.3" D (142 mm L × 119 mm W × 33 mm D)
Wall-Mount Weatherproof Back Box Dimensions (SA-WBB)	5.7" L × 5.1" W × 2.0" D (145 mm L × 130 mm W × 51 mm D)

Notes:

1. Full Wave Rectified (FWR) voltage is a non-regulated, time-varying power source that is used on some power supply and panel outputs.
2. P, S, PC, and SC products will operate at 12 V nominal only for 15 and 15/75 cd.

UL Current Draw Data

UL Max. Strobe Current Draw (mA RMS)						UL Max. Horn Current Draw (mA RMS)					
	Candela	8–17.5 Volts		16–33 Volts		Sound Pattern	dB	8–17.5 Volts		16–33 Volts	
		DC	FWR	DC	FWR			DC	FWR	DC	FWR
Standard Candela Range	15	123	128	66	71	Temporal	High	57	55	69	75
	15/75	142	148	77	81	Temporal	Medium	44	49	58	69
	30	NA	NA	94	96	Temporal	Low	38	44	44	48
	75	NA	NA	158	153	Non-Temporal	High	57	56	69	75
	95	NA	NA	181	176	Non-Temporal	Medium	42	50	60	69
	110	NA	NA	202	195	Non-Temporal	Low	41	44	50	50
	115	NA	NA	210	205	Coded	High	57	55	69	75
High Candela Range	135	NA	NA	228	207	Coded	Medium	44	51	56	69
	150	NA	NA	246	220	Coded	Low	40	46	52	50
	177	NA	NA	281	251						
	185	NA	NA	286	258						

UL Max. Current Draw (mA RMS), 2-Wire Horn Strobe, Standard Candela Range (15–115 cd)									
DC Input	8–17.5 Volts			16–33 Volts					
	15	15/75	15	15/75	30	75	95	110	115
Temporal High	137	147	79	90	107	176	194	212	218
Temporal Medium	132	144	69	80	97	157	182	201	210
Temporal Low	132	143	66	77	93	154	179	198	207
Non-Temporal High	141	152	91	100	116	176	201	221	229
Non-Temporal Medium	133	145	75	85	102	163	187	207	216
Non-Temporal Low	131	144	68	79	96	156	182	201	210
FWR Input									
Temporal High	136	155	88	97	112	168	190	210	218
Temporal Medium	129	152	78	88	103	160	184	202	206
Temporal Low	129	151	76	86	101	160	184	194	201
Non-Temporal High	142	161	103	112	126	181	203	221	229
Non-Temporal Medium	134	155	85	95	110	166	189	208	216
Non-Temporal Low	132	154	80	90	105	161	184	202	211

UL Max. Current Draw (mA RMS), 2-Wire Horn Strobe, High Candela Range (135–185 cd)									
DC Input	16–33 Volts				FWR Input	16–33 Volts			
	135	150	177	185		135	150	177	185
Temporal High	245	259	290	297	Temporal High	215	231	258	265
Temporal Medium	235	253	288	297	Temporal Medium	209	224	250	258
Temporal Low	232	251	282	292	Temporal Low	207	221	248	256
Non-Temporal High	255	270	303	309	Non-Temporal High	233	248	275	281
Non-Temporal Medium	242	259	293	299	Non-Temporal Medium	219	232	262	267
Non-Temporal Low	238	254	291	295	Non-Temporal Low	214	229	256	262

Candela Derating

For K series products used at low temperatures, listed candela ratings must be reduced in accordance with this table.

Strobe Output (cd)	
Listed Candela	Candela rating at –40°F
15	Do not use below 32°F
15/75	
30	
75	
95	44
110	70
115	110
135	115
150	135
177	150
185	177

Horn Tones and Sound Output Data

Horn and Horn Strobe Output (dBA)											
Switch Position	Sound Pattern	dB	8–17.5 Volts		16–33 Volts		24-Volt Nominal				
			DC	FWR	DC	FWR	Reverberant		Anechoic		
			DC	FWR	DC	FWR	DC	FWR	DC	FWR	
1	Temporal	High	78	78	84	84	88	88	99	98	
2	Temporal	Medium	74	74	80	80	86	86	96	96	
3	Temporal	Low	71	73	76	76	83	80	94	89	
4	Non-Temporal	High	82	82	88	88	93	92	100	100	
5	Non-Temporal	Medium	78	78	85	85	90	90	98	98	
6	Non-Temporal	Low	75	75	81	81	88	84	96	92	
7†	Coded	High	82	82	88	88	93	92	101	101	
8†	Coded	Medium	78	78	85	85	90	90	97	98	
9†	Coded	Low	75	75	81	81	88	85	96	92	

†Settings 7, 8, and 9 are not available on 2-wire horn strobe.

SpectrAlert Advance Diagrams

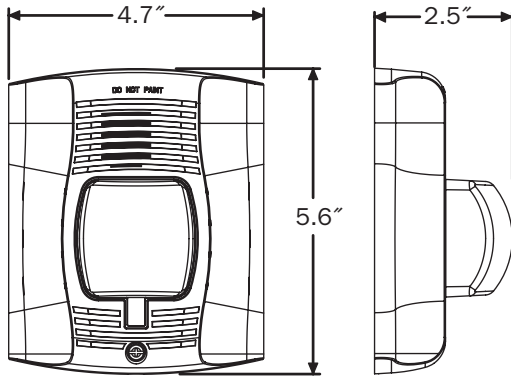

Wall-Mount Horn Strobes

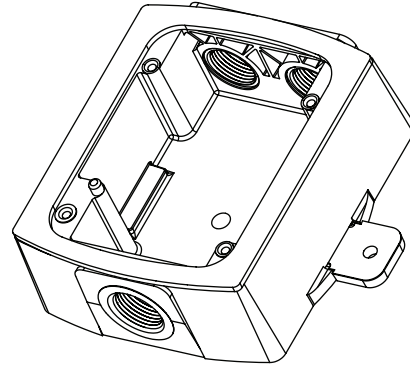

Wall Plastic Weatherproof Back Box

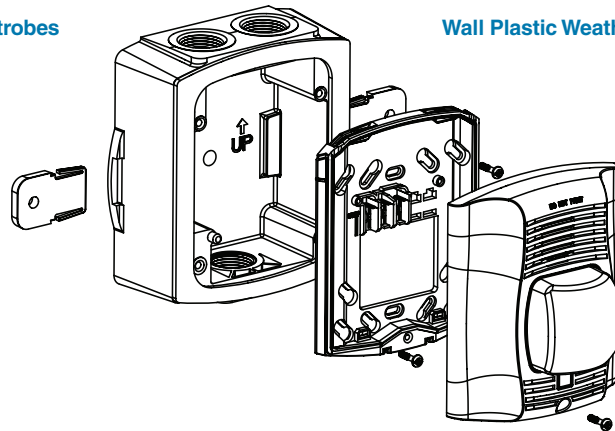

Wall-Mount Horn Strobe with Plastic Weatherproof Back Box

SpectrAlert Advance Ordering Information

Model	Description
Wall Horn Strobes	
P2RK*†	2-Wire Horn Strobe, Standard cd, Red, Outdoor (includes plastic weatherproof back box)
P2RHK*†	2-Wire Horn Strobe, High cd, Red, Outdoor (includes plastic weatherproof back box)
P2WK*†	2-Wire Horn Strobe, Standard cd, White, Outdoor (includes plastic weatherproof back box)
P2WHK*†	2-Wire Horn Strobe, High cd, White, Outdoor (includes plastic weatherproof back box)
P4RK†	4-Wire Horn Strobe, Standard cd, Red, Outdoor (includes plastic weatherproof back box)
P4WK	4-Wire Horn Strobe, Standard cd, White, Outdoor (includes plastic weatherproof back box)
P2RHK-120	2-Wire Horn Strobe, High cd, Red, Outdoor, 120 V (includes plastic weatherproof back box)
Wall Strobes	
SRK*†	Strobe, Standard cd, Red, Outdoor (includes plastic weatherproof back box)
SRHK*†	Strobe, High cd, Red, Outdoor (includes plastic weatherproof back box)
SWK*†	Strobe, Standard cd, White, Outdoor (includes plastic weatherproof back box)
SWHK*†	Strobe, High cd, White, Outdoor (includes plastic weatherproof back box)
Horns	
HRK†	Horn, Red, Outdoor (includes plastic weatherproof back box)
Accessories	
SA-WBB	Red, Metal Weatherproof Back Box
SA-WBBW	White, Metal Weatherproof Back Box

Notes:

* Add "-P" to model number for plain housing (no "FIRE" marking on cover), e.g., P2RK-P.

† Add "-R" to model number for weatherproof replacement device (no back box included), only for use with weatherproof outdoor flush mounting plate, WTP and WTPW. "Standard cd" refers to strobes that include 15, 15/75, 30, 75, 95, 110, and 115 candela settings. "High cd" refers to strobes that include 135, 150, 177, and 185 candela settings. **When replacing standard outdoor units both the device and back box must be replaced.**



3825 Ohio Avenue • St. Charles, IL 60174
Phone: 800-SENSOR2 • Fax: 630-377-6495

©2012 System Sensor.
Product specifications subject to change without notice. Visit systemsensor.com
for current product information, including the latest version of this data sheet.
AVDS01201 • 3/12



Selectable Output Horns, Strobes, and Horn/Strobes

SpectrAlert® Advance selectable-output horns, strobes, and horn/strobes are rich with features guaranteed to cut installation times and maximize profits.



SPECTRAlert
ADVANCE
from System Sensor

Features

- Electrically compatible with existing SpectrAlert products
- Automatic selection of 12- or 24-volt operation at 15 and 15/75 candela
- Plug-in design
- Field selectable candela settings on wall and ceiling units: 15, 15/75, 30, 75, 95, 110, 115, 135, 150, 177, 185
- Same mounting plate for wall- and ceiling-mount units
- Shorting spring on mounting plate for continuity check before installation
- Tamper resistant construction
- Outdoor wall and ceiling products rated from -40°F to 151°F
- Design allows minimal intrusion into the back box
- Horn rated at 88+ dbA at 16 volts
- Rotary switch for horn tone and three volume selections
- Outdoor products UL listed to UL 1638 (strobe) and UL 464 (horn) outdoor requirements
- Outdoor products NEMA 4X rated
- Compatible with MDL sync module

Agency Listings

SIGNALING



54011
55512
53593



3023572

MEA
approved

MEA452-05-E



7125-1653 186 (indoor strobes)
7300-1653 187 (outdoor strobes)
7125-1653 188 (horn/strobes,
chime/strobes)
7135-1653 189 (horns, chimes)

The SpectrAlert Advance series of notification appliances is designed to simplify installations, with features such as plug in designs, instant feedback messages to ensure correct installation of individual devices, and 11 field-selectable candela settings for wall and ceiling strobes and horn/strobes.

When installing Advance products, first attach a universal mounting plate to a four-inch square, four-inch octagon or double-gang junction box. The two-wire mounting plate attaches to a single-gang junction box.

Next, connect the notification appliance circuit wiring to the SEMS terminals on the mounting plate.

Finally, attach the horn, strobe or horn/strobe to the mounting plate by inserting the product's tabs in the mounting plate's grooves. The device will rotate into position, locking the product's pins into the mounting plate's terminals. The device will temporarily hold in place with a catch until it is secured with a captured mounting screw.

The SpectrAlert Advance series includes outdoor notification appliances. Outdoor strobes and horn/strobes (two wire and four wire) are available for wall or ceiling. Outdoor horns are available for wall only. All System Sensor outdoor products are rated between minus 40 degrees Fahrenheit and 151 degrees Fahrenheit in wet or dry applications.

SpectrAlert Advance Specifications

Architect/Engineer Specifications

General

SpectrAlert Advance horns, strobes and horn/strobes shall mount to a standard 4 x 4 x 1½-inch back box, 4-inch octagon back box or double-gang back box. Two-wire products shall also mount to a single-gang 2 x 4 x 1½-inch back box. A universal mounting plate shall be used for mounting ceiling and wall products. The notification appliance circuit wiring shall terminate at the universal mounting plate. Also, SpectrAlert Advance products, when used with the Sync-Circuit™ Module accessory, shall be powered from a non-coded notification appliance circuit output and shall operate on a nominal 12 or 24 volts. When used with the Sync-Circuit Module, 12-volt rated notification appliance circuit outputs shall operate between nine and 17.5 volts; 24-volt rated notification appliance circuit outputs shall operate between 17 and 33 volts. Indoor SpectrAlert Advance products shall operate between 32 and 120 degrees Fahrenheit from a regulated DC, or full-wave rectified, unfiltered power supply. Strobes and horn/strobes shall have field-selectable candela settings including 15, 15/75, 30, 75, 95, 110, 115, 135, 150, 177, 185.

Strobe

The strobe shall be a System Sensor SpectrAlert Advance Model _____ listed to UL 1971 and shall be approved for fire protective service. The strobe shall be wired as a primary-signaling notification appliance and comply with the Americans with Disabilities Act requirements for visible signaling appliances, flashing at 1Hz over the strobe's entire operating voltage range. The strobe light shall consist of a xenon flash tube and associated lens/reflector system.

Horn/Strobe Combination

The horn/strobe shall be a System Sensor SpectrAlert Advance Model _____ listed to UL 1971 and UL 464 and shall be approved for fire protective service. The horn/strobe shall be wired as a primary-signaling notification appliance and comply with the Americans with Disabilities Act requirements for visible signaling appliances, flashing at 1Hz over the strobe's entire operating voltage range. The strobe light shall consist of a xenon flash tube and associated lens/reflector system. The horn shall have three audibility options and an option to switch between a temporal three-pattern and a non-temporal (continuous) pattern. These options are set by a multiple position switch. On four-wire products, the strobe shall be powered independently of the sounder. The horn on horn/strobe models shall operate on a coded or non-coded power supply.

Outdoor Products

SpectrAlert Advance outdoor horns, strobes and horn/strobes shall be listed for outdoor use by UL and shall operate between minus 40 degrees and 151 degrees Fahrenheit. The products shall be listed for use with a System Sensor outdoor/weatherproof back box with half inch and three-fourths inch conduit entries.

Synchronization Module

The module shall be a System Sensor Sync-Circuit model MDL listed to UL 464 and shall be approved for fire protective service. The module shall synchronize SpectrAlert strobes at 1Hz and horns at temporal three. Also, while operating the strobes, the module shall silence the horns on horn/strobe models over a single pair of wires. The module shall mount to a 4½" x 4½" x 2½" back box. The module shall also control two Style Y (class B) circuits or one Style Z (class A) circuit. The module shall synchronize multiple zones. Daisy chaining two or more synchronization modules together will synchronize all the zones they control. The module shall not operate on a coded power supply.

Physical/Electrical Specifications

Standard Operating Temperature	32°F to 120°F (0°C to 49°C)
K Series Operating Temperature	-40°F to 151°F (-40°C to 66°C)
Humidity Range	10 to 93% non-condensing (indoor products)
Strobe Flash Rate	1 flash per second
Nominal Voltage	Regulated 12DC/FWR or regulated 24DC/FWR ¹
Operating Voltage Range²	8 to 17.5 V (12V nominal) or 16 to 33 V (24 nominal)
Input terminal wire gauge	12 to 18 AWG
Ceiling mount dimensions (including lens)	6.8" diameter x 2.5" high (173 mm diameter x 64 mm high)
Wall mount dimensions (including lens)	5.6"L x 4.7"W x 2.5"D (142 mm L x 119 mm W x 64 mm D)
Horn dimensions	5.6"L x 4.7"W x 1.3"D (142 mm L x 119 mm W x 33 mm D)
Wall-mount back box skirt dimensions (BBS-2, BBSW-2)	5.9"L x 5.0"W x 2.2"D (151 mm L x 128 mm W x 56 mm D)
Ceiling-mount back box skirt dimensions (BBSC-2, BBSCW-2)	7.1" diameter x 2.25" high (180 mm diameter x 57 mm high)
Wall-mount weatherproof back box dimensions (SA-WBB)	5.7"L x 5.1"W x 2.0"D (145 mm L x 130 mm W x 51 mm D)
Ceiling-mount weatherproof back box dimensions (SA-WBBC)	7.1" diameter x 2.0" high (180 mm diameter x 51 mm high)
Wall-mount trim ring dimensions (TR-HS, TRW-HS)	5.7"L x 4.812"W x 0.35"D (146 mm L x 122 W mm x 9 D mm)
Ceiling-mount trim ring dimensions (TRC-HS, TRCW-HS)	6.9" diameter x 0.35 high (176 mm diameter x 9 mm high)

Notes:

1. Full Wave Rectified (FWR) voltage is a non-regulated, time varying power source that is used on some power supply and panel outputs.
2. P, S, PC, and SC products will operate at 12 V nominal only for 15 and 15/75 cd.

UL Current Draw Data

UL Max. Strobe Current Draw (mA RMS)					
Candela	8-17.5 Volts		16-33 Volts		FWR
	DC	FWR	DC	FWR	
Standard Candela Range					
15*	123	128	66	71	
15/75*	142	148	77	81	
30*	NA	NA	94	96	
75*	NA	NA	158	153	
95*	NA	NA	181	176	
110	NA	NA	202	195	
115	NA	NA	210	205	
High Candela Range					
135	NA	NA	228	207	
150	NA	NA	246	220	
177	NA	NA	281	251	
185	NA	NA	286	258	

UL Max. Horn Current Draw (mA RMS)					
Sound Pattern	dB	8-17.5 Volts		16-33 Volts	
		DC	FWR	DC	FWR
Temporal	High	57	55	69	75
Temporal	Medium	44	49	58	69
Temporal	Low	38	44	44	48
Non-temporal	High	57	56	69	75
Non-temporal	Medium	42	50	60	69
Non-temporal	Low	41	44	50	50
Coded	High	57	55	69	75
Coded	Medium	44	51	56	69
Coded	Low	40	46	52	50

UL Max. Current Draw (mA RMS), 2-wire Horn/Strobe, Standard Candela Range (15-115 cd)									
DC Input	8-17.5 Volts			16-33 Volts			95	110	115
	15	15/75	15	15/75	30	75			
Temporal High	137	147	79	90	107	176	194	212	218
Temporal Medium	132	144	69	80	97	157	182	201	210
Temporal Low	132	143	66	77	93	154	179	198	207
Non-temporal High	141	152	91	100	116	176	201	221	229
Non-temporal Medium	133	145	75	85	102	163	187	207	216
Non-temporal Low	131	144	68	79	96	156	182	201	210
FWR Input									
Temporal High	136	155	88	97	112	168	190	210	218
Temporal Medium	129	152	78	88	103	160	184	202	206
Temporal Low	129	151	76	86	101	160	184	194	201
Non-temporal High	142	161	103	112	126	181	203	221	229
Non-temporal Medium	134	155	85	95	110	166	189	208	216
Non-temporal Low	132	154	80	90	105	161	184	202	211

UL Max. Current Draw (mA RMS), 2-wire Horn/Strobe, High Candela Range (135-185 cd)									
DC Input	16-33 Volts				FWR Input	16-33 Volts			
	135	150	177	185		135	150	177	185
Temporal High	245	259	290	297	Temporal High	215	231	258	265
Temporal Medium	235	253	288	297	Temporal Medium	209	224	250	258
Temporal Low	232	251	282	292	Temporal Low	207	221	248	256
Non-temporal High	255	270	303	309	Non-temporal High	233	248	275	281
Non-temporal Medium	242	259	293	299	Non-temporal Medium	219	232	262	267
Non-temporal Low	238	254	291	295	Non-temporal Low	214	229	256	262

Candela Derating

For K series products used at low temperatures, listed candela ratings must be reduced in accordance with this table.

Strobe Output (cd)	
Listed Candela	Candela rating at -40°F
15	Do not use below 32°F
15/75	
30	
75	
95	44
110	70
115	110
135	115
150	135
177	150
185	177

Horn Tones and Sound Output Data

Horn and Horn/Strobe Output (dBA)										
Switch Position	Sound Pattern	dB	8-17.5 Volts		16-33 Volts		24 Volt Nominal			
			DC	FWR	DC	FWR	Reverberant		Anechoic	
							DC	FWR	DC	FWR
1	Temporal	High	78	78	84	84	88	88	99	98
2	Temporal	Medium	74	74	80	80	86	86	96	96
3	Temporal	Low	71	73	76	76	83	80	94	89
4	Non-temporal	High	82	82	88	88	93	92	100	100
5	Non-temporal	Medium	78	78	85	85	90	90	98	98
6	Non-temporal	Low	75	75	81	81	88	84	96	92
7 [†]	Coded	High	82	82	88	88	93	92	101	101
8 [†]	Coded	Medium	78	78	85	85	90	90	97	98
9 [†]	Coded	Low	75	75	81	81	88	85	96	92

[†]Settings 7, 8, and 9 are not available on 2-wire horn/strobe.

SpectrAlert Advance Dimensions

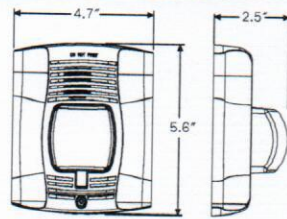

Wall-mount horn/strobes

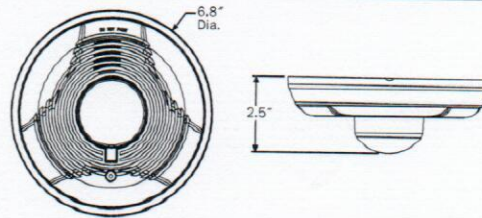

Ceiling-mount horn/strobes

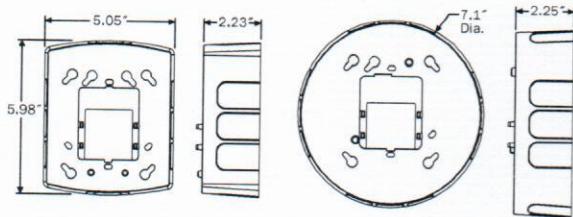

Wall back box skirt

Ceiling back box skirt

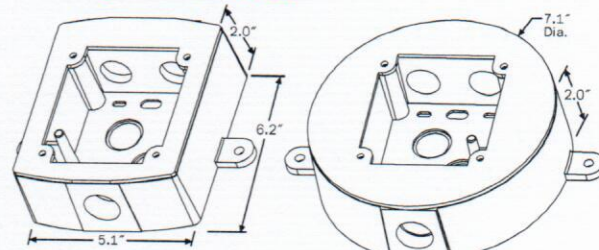

Wall weatherproof back box

Ceiling weatherproof back box

SpectrAlert Advance Ordering Information

Model	Description
Wall Horn/Strobes	
P2R*†	2-wire Horn/Strobe, Standard cd†, Red
P2RH*	2-wire Horn/Strobe, High cd, Red
P2RK*‡	2-wire Horn/Strobe, Standard cd, Red, Outdoor
P2RHK‡	2-wire Horn/Strobe, High cd, Red, Outdoor
P2W*	2-wire Horn/Strobe, Standard cd, White
P2WH*	2-wire Horn/Strobe, High cd, White
P4R*	4-wire Horn/Strobe, Standard cd, Red
P4RH*	4-wire Horn/Strobe, High cd, Red
P4RK‡	4-wire Horn/Strobe, Standard cd, Red, Outdoor
P4RHK‡	4-wire Horn/Strobe, High cd, Red, Outdoor
P4W*	4-wire Horn/Strobe, Standard cd, White
P4WH*	4-wire Horn/Strobe, High cd, White
Wall Strobes	
SR*†	Strobe, Standard cd, Red
SRH*†	Strobe, High cd, Red
SRK‡	Strobe, Standard cd, Red, Outdoor
SRHK	Strobe, High cd, Red, Outdoor
SW*	Strobe, Standard cd, White
SWH*	Strobe, High cd, White
Ceiling Horn/Strobes	
PC2R*	2-wire Horn/Strobe, Standard cd, Red
PC2RH*	2-wire Horn/Strobe, High cd, Red
PC2RK*‡	2-wire Horn/Strobe, Standard cd, Red, Outdoor
PC2RHK‡	2-wire Horn/Strobe, High cd, Red, Outdoor
PC2W*†	2-wire Horn/Strobe, Standard cd, White
PC2WH*†	2-wire Horn/Strobe, High cd, White
PC4R	4-wire Horn/Strobe, Standard cd, Red
PC4RH	4-wire Horn/Strobe, High cd, Red
PC4RK	4-wire Horn/Strobe, Standard cd, Red, Outdoor
PC4RHK‡	4-wire Horn/Strobe, High cd, Red, Outdoor

Model	Description
Ceiling Horn/Strobes (cont'd.)	
PC4W	4-wire Horn/Strobe, Standard cd, White
PC4WH	4-wire Horn/Strobe, High cd, White
Ceiling Strobes	
SCR*	Strobe, Standard cd, Red
SCRH*	Strobe, High cd, Red
SCRK‡	Strobe, Standard cd, Red, Outdoor
SCRHK‡	Strobe, High cd, Red, Outdoor
SCW*†	Strobe, Standard cd, White
SCWH*†	Strobe, High cd, White
Horns	
HR	Horn, Red
HRK‡	Horn, Red, Outdoor
HW	Horn, White
Accessories	
BBS-2	Back Box Skirt, Wall, Red
BBSW-2	Back Box Skirt, Wall, White
BBSC-2	Back Box Skirt, Ceiling, Red
BBSCW-2	Back Box Skirt, Ceiling, White
TR-HS	Trim Ring, Wall, Red
TRW-HS	Trim Ring, Wall White
TRC-HS	Trim Ring, Ceiling, Red
TRCW-HS	Trim Ring, Ceiling, White

Notes:

* Add "-P" to model number for plain housing (no "FIRE" marking on cover), e.g., P2R-P.

† Add "-SP" to model number for "FUEGO" marking on cover, e.g., P2R-SP.

‡ "Standard cd," refers to strobes that include 15, 15/75, 30, 75, 95, 110, and 115 candela settings. "High cd," refers to strobes that include 135, 150, 177, and 185 candela settings.

All outdoor units ending in "K" include a weatherproof back box.

‡ Add "-R" to model number for weatherproof replacement device (no back box included).



3825 Ohio Avenue • St. Charles, IL 60174
Phone: 800-SENSOR2 • Fax: 630-377-6495

©2008 System Sensor.
Product specifications subject to change without notice. Visit systemsensor.com for current product information, including the latest version of this data sheet.
A05-0395-015 • 8/08 • #2018



Selectable-Output Low Frequency Sounder and Low Frequency Sounder Strobes for Wall Applications

SpectrAlert® Advance audible visible notification products are rich with features guaranteed to cut installation times and maximize profits.

Features

- 520 Hz \pm 10% square wave tone
- Plug-in design with minimal intrusion into the back box
- Tamper-resistant construction
- Field-selectable candela settings on wall units: 135, 150, 177, and 185
- Rotary switch for low frequency sounder tone
- Universal mounting plate for wall units
- Mounting plate shorting spring checks wiring continuity before device installation
- Electrically compatible with legacy SpectrAlert devices
- Compatible with MDL3 sync module
- Listed for ceiling or wall mounting

Agency Listings

SIGNALING



S4011 (sounder)
S5512 (strobes)



3047563

MEA
approved

MEA452-05-E



7135-1653:0223
7125-1653:0224



SPECTRAlert
ADVANCE
from System Sensor

The SpectrAlert Advance series offers the most versatile and easy-to-use line of low frequency sounder and low frequency sounder strobes in the industry. With white and red plastic housings, dual listed for wall and ceiling mounting, SpectrAlert Advance can meet virtually any application requirement.

The wall-mount low frequency sounder, and low frequency sounder strobes were designed to address the NFPA 72 sleeping space requirements that require a low frequency notification appliance that operates within frequency range of 520 Hz \pm 10% and is of a square wave tone. Like the entire SpectrAlert Advance product line they include a variety of features that increase their application versatility while simplifying installation. All devices feature plug-in designs with minimal intrusion into the back box, making installations fast and foolproof while virtually eliminating costly and time-consuming ground faults.

To further simplify installation and protect devices from construction damage, SpectrAlert Advance utilizes a universal mounting plate with an onboard shorting spring, so installers can test wiring continuity before the device is installed.

Installers can also easily adapt devices to a suit a wide range of application requirements using field-selectable candela settings, automatic selection of 12- or 24-volt operation, and a rotary switch for 520 Hz low frequency sounder tones.

SpectrAlert Advance Specifications

Architect/Engineer Specifications

General

SpectrAlert Advance low frequency sounder and low frequency sounder strobes shall mount to a standard 4 × 4 × 1½-inch back box, 4-inch octagon back box, or double-gang back box. Two-wire products shall also mount to a single-gang 2 × 4 × 17/8-inch back box. A universal mounting plate shall be used for mounting products. The notification appliance circuit wiring shall terminate at the universal mounting plate. Also, SpectrAlert Advance products, when used with the Sync•Circuit™ Module accessory, shall be powered from a non-coded notification appliance circuit output and shall operate on a nominal 12 or 24 volts. When used with the Sync•Circuit Module, 12-volt-rated notification appliance circuit outputs shall operate between 8.5 and 17.5 volts; 24-volt-rated notification appliance circuit outputs shall operate between 16.5 and 33 volts. Indoor SpectrAlert Advance products shall operate between 32 and 120 degrees Fahrenheit from a regulated DC or full-wave rectified unfiltered power supply. Low Frequency Sounder strobes shall have field-selectable candela settings including 135, 150, 177, and 185. The field selectable tones will sound within the frequency range of 520 Hz ±10% square wave tone and have a permanent marking on the housing that reads "low frequency sounder".

Low Frequency Sounder

The low frequency sounder shall be a System Sensor SpectrAlert Advance Model _____ listed to UL 464 and shall be approved for fire protective service. The low frequency sounder and the Sync•Circuit™ MDL3 Module accessory, if used, shall be powered from a notification appliance circuit output and shall operate on a nominal 12 or 24 volts (includes fire alarm panels with built in sync). When used with the Sync•Circuit Module MDL3, 12-volt rated notification appliance circuit outputs shall operate between 8.5 and 17.5 volts; 24-volt rated notification appliance circuit outputs shall operate between 16.5 to 33 volts. If the notification appliances are not UL 9th edition listed with the corresponding panel or power supply being used, then refer to the compatibility listing of the panel to determine maximum devices on a circuit. The low frequency sounder has an option to switch between temporal three pattern, non-temporal (continuous) pattern and coded supply within the frequency range of 520Hz ± 10% square wave tone. The low frequency sounder shall operate on a coded or non-coded power supply.

Low Frequency Sounder Strobe Combination

The low frequency sounder strobe shall be a System Sensor SpectrAlert Advance Model _____ listed to UL 1971 and UL 464 and shall be approved for fire protective service. The low frequency sounder strobe shall be wired as a primary-signaling notification appliance and comply with the Americans with Disabilities Act requirements for visible signaling appliances, flashing at 1 Hz over the strobe's entire operating voltage range. The strobe light shall consist of a xenon flash tube and associated lens/reflector system. The sounder shall have an option to switch between a temporal three pattern and a non-temporal (continuous) pattern. These options are set by a multiple position switch. The low frequency sounder on low frequency sounder strobe models shall operate on a non-coded power supply. The field selectable tones will sound within the frequency range of 520 Hz ±10% square wave tone.

Synchronization Module

The module shall be a System Sensor Sync•Circuit model MDL3 listed to UL 464 and shall be approved for fire protective service. The module shall synchronize SpectrAlert strobes at 1 Hz and low frequency sounder at temporal three. Also, while operating the strobes, the module shall silence the low frequency sounder on low frequency sounder strobe models over a single pair of wires. The module shall mount to a 4^{11/16} × 4^{11/16} × 2^{1/8}-inch back box. The module shall also control two Style Y (class B) circuits or one Style Z (class A) circuit. The module shall synchronize multiple zones. Daisy chaining two or more synchronization modules together will synchronize all the zones they control. The module shall not operate on a coded power supply.

Physical/Electrical Specifications

Standard Operating Temperature	32°F to 120°F (0°C to 49°C)
Humidity Range	10 to 93% non-condensing
Frequency Range	520 Hz ± 10%
Strobe Flash Rate	1 flash per second
Nominal Voltage Low Frequency Sounder	Regulated 12 DC/FWR or regulated 24 DC/FWR ¹
Nominal Voltage Range Low Frequency Sounder Strobe	Regulated 24 VDC/FWR ¹
Operating Voltage Range	8 to 17.5 V (12 V nominal) or 16 to 33 V (24 V nominal)
Operating Voltage Range MDL3 Sync Module	8.5 to 17.5 V (12 V nominal) or 16.5 to 33 V (24 V nominal)
Input Terminal Wire Gauge	12 to 18 AWG
Wall-Mount Dimensions (including lens)	6.4 inches L x 4.7 inches W x 2.5 inches D (162 mm L x 119 mm W x 64 mm D)
Sounder Dimensions	5.6 inches L x 4.7 inches W x 1.3 inches D (142 mm L x 119 mm W x 33 mm D)
Low Frequency Sounder/Strobe with Surface Mount Back Box Dimensions (SBBR, SBBW)	6.4 inches L x 4.7 inches W x 4.3 inches D (162 mm L x 120 mm W x 108 mm D)
Low Frequency Sounder with Surface Mount Back Box Dimensions (SBBR, SBBW)	5.7 inches L x 4.8 inches W x 3 inches D (145 mm L x 120 mm W x 76 mm D)

Notes:

1. Full Wave Rectified (FWR) voltage is a non-regulated, time-varying power source that is used on some power supply and panel outputs.

UL Current Draw Data

UL Max. Strobe Current Draw (mA RMS)					
	Candela	8–17.5 Volts		16–33 Volts	
		DC	FWR	DC	FWR
High Candela Range	135	NA	NA	228	207
	150	NA	NA	246	220
	177	NA	NA	281	251
	185	NA	NA	286	258

UL Max. Low Frequency Current Draw (mA RMS)					
Sound Pattern	dB	8–17.5 Volts		16–33 Volts	
		DC	FWR	DC	FWR
Temporal 3	High	191	262	138	166
Continuous	High	292	384	138	208
Coded	High	292	388	153	205

UL Max. Current Draw (mA RMS), 2-Wire Low Frequency Sounder Strobe, High Candela Range (135–185 cd)									
DC Input	16–33 Volts				FWR Input	16–33 Volts			
	135	150	177	185		135	150	177	185
Temporal 3	277	292	325	344	Temporal 3	296	309	343	351
Continuous	337	362	387	417	Continuous	393	395	432	433

Low Frequency Sounder Tones and Sound Output Data

Low Frequency Sounder and Low Frequency Sounder Strobe Output (dBA)									
Switch Position	Sound Pattern	8–17.5 Volts		16–33 Volts		24-Volt Nominal			
						Reverberant		Anechoic	
		DC	FWR	DC	FWR	DC	FWR	DC	FWR
1	Temporal 3	76	76	76	76	76	76	86	86
2	Continuous	80	80	80	80	80	80	90	90
3†	Coded	80	80	80	80	80	80	90	90

† Sounder ratings provided are for continuous voltage as provided by the NAC

SpectrAlert Advance Dimensions

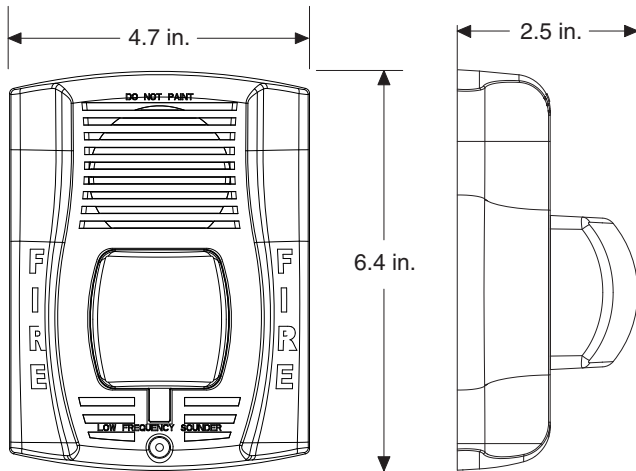

Wall-mount low frequency sounder strobes

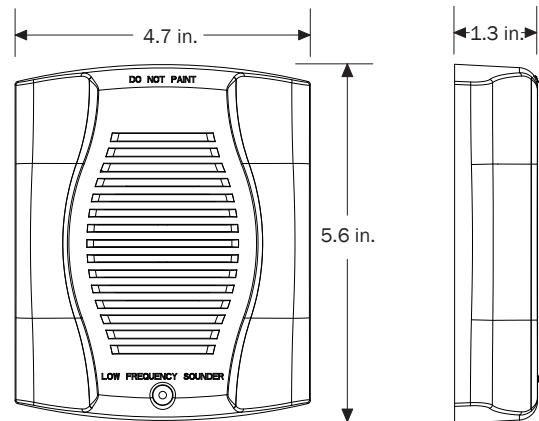

Wall-mount low frequency sounder

SpectrAlert Advance Ordering Information

Model	Description
Wall Low Frequency Sounder Strobes	
P2RH-LF	2-Wire Low Frequency Sounder Strobe, High cd, Red
P2WH-LF	2-Wire Low Frequency Sounder Strobe, High cd, White
Low Frequency Sounders	
HR-LF	Low Frequency Sounder, Red
HW-LF	Low Frequency Sounder, White
Accessories	
SBBR	Surface Mount Back Box, Wall, Red
SBBW	Surface Mount Back Box, Wall, White
TR-HS	Trim Ring, Wall, Red

Notes:

"High cd" refers to strobes that include 135, 150, 177, and 185 candela settings.



3825 Ohio Avenue • St. Charles, IL 60174
 Phone: 800-SENSOR2 • Fax: 630-377-6495
www.systemsensor.com

©2014 System Sensor.
 Product specifications subject to change without notice. Visit systemsensor.com
 for current product information, including the latest version of this data sheet.
 AVDS16403 • 5/14



Indoor Selectable-Output Speaker Strobes and Dual Voltage Evacuation Speakers for Wall Applications

The new SpectrAlert® Advance selectable output speaker strobes and dual-voltage evacuation speakers can reduce ground faults and enable faster installation.

Features

- Plug-in design and protective cover reduce ground faults
- Universal mounting plate with an onboard shorting spring tests wiring continuity before installation
- No extension ring required
- Field selectable candela settings:
Standard: 15, 15/75, 30, 75, 95, 110, 115
High: 135, 150, 177, 185
- Automatic selection of 12- or 24-volt operation at 15 and 15/75 candela
- Rotary switch simplifies field selection of speaker voltage (25 and 70.7 Vrms) and power settings (¼, ½, 1 and 2 watts)
- SP speakers offer high fidelity sound output
- SPV speakers offer high volume sound output
- Compatible with System Sensor synchronization protocol
- Electrical compatibility with existing SpectrAlert products
- Optional tamper resistant Torx head screw included

Agency Listings



The SpectrAlert Advance Series of speakers and speaker strobes reduce costly ground faults using a plug-in design and universal mounting plate that allow the installer to pre-wire mounting plates, dress the wires, and confirm wiring continuity before plugging in the speakers. In addition, a protective plastic cover prevents nicked wires by covering exposed speaker components.

These devices also enable faster installations by providing instant feedback to ensure that wiring is properly connected, rotary switches to select voltage and power settings, and 11 field-selectable candela settings for both wall and ceiling speaker strobes.

The low total harmonic distortion of the SP speaker offers high fidelity sound output while the SPV speaker offers high volume sound output for use in high ambient noise applications.

SpectrAlert Advance makes installation easy

- Attach a universal mounting plate to a 4 × 4 × 2⅞ inch back box. Flush-mount applications do not require an extension ring.
- Connect the notification appliance circuit or speaker wiring to the terminals on the mounting plate.
- Attach the speaker or speaker strobe to the mounting plate by inserting the product tabs into the mounting plate grooves. Rotate the device into position to lock the product pins into the mounting plate terminals. The device will temporarily hold in place with a catch until it is secured with a captured mounting screw.

SpectrAlert Advance Speaker and Speaker Strobe Specifications

Architectural/Engineering Specifications

General

SpectrAlert Advance speaker and speaker strobes shall mount to a 4 × 4 × 2¹/₈-inch back box. A universal mounting plate shall be used for mounting ceiling and wall products. The notification appliance circuit and amplifier wiring shall terminate at the universal mounting plate. Also, SpectrAlert Advance speaker strobes, when used with the Sync-Circuit™ Module accessory, shall be powered from a non-coded notification appliance circuit output and shall operate on a nominal 12 or 24 volts. When used with the Sync-Circuit Module, 12-volt rated notification appliance circuit outputs shall operate between nine and 17.5 volts; 24-volt rated notification appliance circuit outputs shall operate between 17 and 33 volts. Indoor SpectrAlert Advance products shall operate between 32°F and 120°F from a regulated DC, or full-wave rectified, unfiltered power supply. Speaker strobes shall have field-selectable candela settings including 15, 15/75, 30, 75, 95, 110, 115, 135, 150, 177, 185.

Speaker

The speaker shall be a System Sensor SpectrAlert Advance model _____ dual-voltage transformer speaker capable of operating at 25.0 or 70.7 nominal Vrms. It should be listed to UL 1480 and shall be approved for fire protective service. The speaker shall have a frequency range of 400 to 4,000 Hz and shall have an operating temperature between 32°F and 120°F. The speaker shall have power taps and voltage that are selected by rotary switches.

Speaker Strobe combination

The speaker strobe shall be a System Sensor SpectrAlert Advance model _____ listed to UL1480 and UL 1971 and be approved for fire protective signaling systems. The speaker shall be capable of operating at 25.0 or 70.7 nominal Vrms selected via rotary switch, and shall have a frequency range of 400 to 4,000 Hz. The speaker shall have power taps that are selected by rotary switch. The strobe shall comply with the NFPA 72 requirements for visible signaling appliances, flashing at 1 Hz over the strobe's entire operating voltage range. The strobe light shall consist of a xenon flash tube and associated lens/reflector system.

Synchronization Module

The module shall be a System Sensor Sync-Circuit model MDL listed to UL 464 and shall be approved for fire protective service. The module shall synchronize SpectrAlert strobes at 1 Hz. The module shall mount to a 4¹¹/₁₆ × 4¹¹/₁₆ × 2¹/₈-inch back box. The module shall also control two Style Y (class B) circuits or one Style Z (class A) circuit. The module shall synchronize multiple zones. Daisy chaining two or more synchronization modules together will synchronize all the zones they control. The module shall not operate on a coded power supply.

Physical Specifications

Operating Temperature	32°F to 120°F (0°C to 49°C)
Humidity Range	10 to 93% non-condensing
Dimensions, Wall-Mount	
SPS Speaker Strobe	6.0 in L × 5.0 in W × 4.7 in D (including lens and speaker)
SPSV Speaker Strobe	6.0 in L × 5.0 in W × 4.9 in D (including lens and speaker)
SP Speaker	6.0 in L × 5.0 in W × 2.8 in D
SPSV Speaker	6.0 in L × 5.0 in W × 2.9 in D

Electrical/Operating Specifications

Nominal Voltage (speakers)	25 Volts or 70.7 Volts (nominal)
Maximum Supervisory Voltage (speakers)	50 VDC
Strobe Flash Rate	1 flash per second
Nominal Voltage (strobes)	Regulated 12 VDC/FWR or regulated 24 DC/FWR
Operating Voltage Range (includes fire alarm panels with built in sync)	8 to 17.5 V (12 V nominal) or 16 to 33V (24 V nominal)
Operating Voltage with MDL Sync Module	9 to 17.5 V (12 V nominal) or 17 to 33V (24 V nominal)
Frequency Range	400 to 4000 Hz
Power	¼, ½, 1, 2 watts

UL Current Draw Data

UL Max. Strobe Current Draw (mA RMS)					
	Candela	8 to 17.5 Volts		16 to 33 Volts	
		DC	FWR	DC	FWR
Standard Candela Range	15	123	128	66	71
	15/75	142	148	77	81
	30	NA	NA	94	96
	75	NA	NA	158	153
	95	NA	NA	181	176
	110	NA	NA	202	195
	115	NA	NA	210	205
High Candela Range	135	NA	NA	228	207
	150	NA	NA	246	220
	177	NA	NA	281	251
	185	NA	NA	286	258

Sound Output				
UL Reverberant (dBA @ 10 ft.)	2W	1W	½ W	¼ W
Wall-Mount SP Series	86	83	80	77
Wall-Mount SPV Series	90	87	84	81
Wall-Mount SPS Series	85	82	79	76
Wall-Mount SPSV Series	89	86	83	80

Dimensions

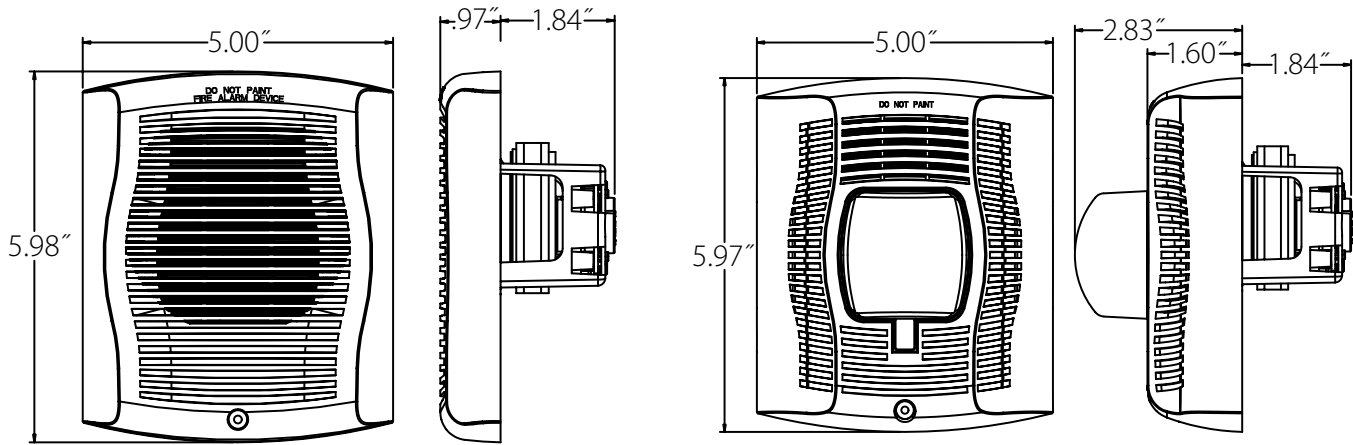

Wall-Mount SP Speaker

Wall-Mount SPS Speaker Strobe

Surface Mounting

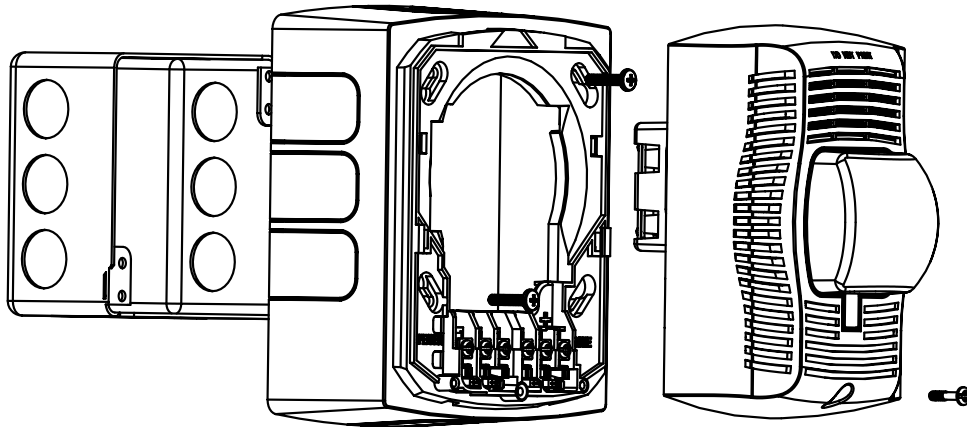

Wall-Mount Speaker Strobe with SPBBS Back Box Skirt

Ordering Information for SpectrAlert® Advance Speakers and Speaker Strobes

Wall Mount		
White	Red	Description
SPW	SPR	Speaker only
SPWV	SPRV	Speaker only, High dB
SPSW*	SPSR*	Speaker Strobe, Selectable Candela (15, 15/75, 30, 75, 95, 110, 115)
SPSWH*	SPSRH*	Speaker Strobe, Selectable Candela, High cd (135, 150, 177, 185)
SPSWV*	SPSRV*	Speaker Strobe, Selectable Candela (15, 15/75, 30, 75, 95, 110, 115), High dB
Accessories		
White	Red	Description
RFPW	RFP	7 in x 9.5 in Retrofit Plate
SPBBSW	SPBBS	Wall Mount Back Box Skirt
TRW	TR	Wall Mount Trim Ring

* Add -P to model number for plain housing (no "FIRE" marking on the cover) e.g. SPSW-P



3825 Ohio Avenue • St. Charles, IL 60174
Phone: 800-SENSOR2 • Fax: 630-377-6495

©2011 System Sensor.
Product specifications subject to change without notice. Visit systemsensor.com for current product information, including the latest version of this data sheet.
AVDS00800 • 6/11 • #2809

PART NUMBER MCF-761360-S500

UL Listed and Rated Type CMP or FPLP / FAMC

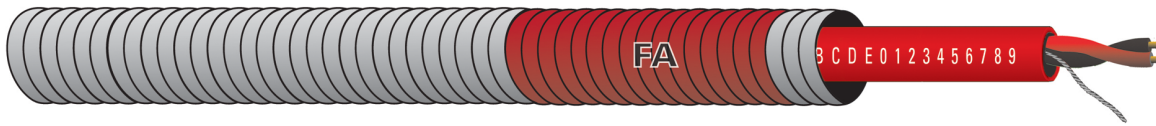

CABLE SPECIFICATIONS

DESCRIPTION	16 AWG 2 Conductor Bare Copper, Non-Shielded FPLP, UL C(UL) CMP or FPLP UL
CONDUCTOR	16 (Solid Bare Copper)
INSULATION	Low-Smoke PVC .010"
COLOR CODE	Black/Red
JACKET	Low-Smoke PVC .018"
JACKET COLOR	Red Jacket
MARKING	FIRE/LIFE SAFETY CONTROL CABLE INIT. / IND. DEVICE / ZONE A B C D E 0 1 2 3 4 5 6 7 8 9 16 AWG UL C(UL) CMP OR FPLP UL ROHS SLC MADE IN THE USA
OVERALL DIAMETER	Overall MC Diameter = .400" Nom. MC Armor Material = Aluminum
CABLE WEIGHT	60 Lbs/Mft.
CAPACITANCE	22 pF/Ft.
TEMPERATURE RATING	0 C to 75 C / 300 Volt

INDUSTRY STANDARDS

FLAME RATING	APPROVED FOR PLENUM USE WITHOUT CONDUIT PER NFPA 262 FLAME TEST
AGENCY APPROVALS	UL 62, 83, 910, 1424, 1479, 1569, 1581 NEC 300.22(C), 330, 430-472, 518, 530, 645, 727, 760.71(D) COMPLIES WITH FEDERAL SPECIFICATIONS A-A-59544(FORMERLY J-C-30B) MADE IN THE U.S.A. FULLY PRE-ASSEMBLED AND INSPECTED IN HAZARDOUS LOCATIONS UP TO CLASS I & II, DIV.2 AND CLASS III, DIV. 1 & 2 (AS SPECIFIED IN NEC ARTICLES 501, 502, AND 503) NEC ARTICLE 800, 760; UL C(UL) CMP OR FPLP UL, ROHS COMPLIANT, MADE IN THE USA





GENESIS SERIES

**Power Limited Fire Alarm Cable
Part No. 4602**

Description: 18 AWG 2/C Solid Shielded FPLP-CL2P
Compliance: UL Standards 13 & 1424; NEC Articles 725 & 760

Construction:

Conductor 18 AWG Solid Bare Copper
No. of Conductors 2

Insulation

Type Plenum PVC
Color Black, Red
Thickness 0.007" nom.
Diameter 0.054" nom"
Lay Length 2.25" nom.
Drain Wire 24 Solid Tinned-Copper
Shield 0.001" thick Aluminum/Mylar

Jacket

Type Plenum PVC
Color Red
Thickness 0.015" nom.
Diameter 0.140" nom.
Legend (Ink Print) **HONEYWELL P/N 4602 2C18 SHIELDED E175105 (ETL) FPLP OR CL2P C(UL)US
FT6 75C (RoHS) W/O# XXXXXX-XXXXXX XXXXFT DEVICE/ZONE A B C D E F 1 2 3
4 5 6 7 8 9**

Properties:

Temperature Rating -20 to 75°C
Operating Voltage 300 Volts max.
Capacitance 68 pf/ft nom.
Impedance 30 Ohms nom.
DC Resistance 6.5 Ohms/M' at 20°C
Flame Rating UL 910, NFPA 262, C(UL) FT6

**Technical Data Sheet
Fire Alarm Cables**

WEST PENN WIRE



2833 West Chestnut Street
Washington, PA 15301
Toll Free: (800) 245-4964
Fax: (724) 222-6420
www.westpenn-wpw.com

PART NUMBER:	60991BS
DESCRIPTION:	16/2 Stranded bare copper conductors, unshielded with an overall jacket.
NEC RATING:	FPLP, NEC Article 760
APPROVALS:	(UL) Listed
APPLICATION:	Indoor within ducts, plenums, and other spaces used for environmental air for (Audio Circuits, Control Circuits, Initiating Circuits, Notification Circuits)

Construction Parameters:

Conductor	16 AWG Bare Copper
Stranding	Stranded
Insulation Material	PVC
Insulation Thickness	0.008" Nom.
Number of Conductors	2
Shield	None
Drain	None
Jacket Material	PVC
Jacket Thickness	0.015" Nom.
Overall Cable Diameter	0.164" Nom.
Approximate Cable Weight	26 Lbs/1M' Nom.
Flame Rating	NFPA- 262 Flame Test

Electrical & Environmental Properties:

Temperature Rating	-10deg C to 60deg C
Operating Voltage	300 V RMS
Max.Capacitance Between Conductors @ 1 KHz	32 pf/ft Nom.
DC Resistance per Conductor @ 20deg C	4.1 Ohms/1M' Nom.
Insulation Colors	Black, Red
Jacket Color	Red
RoHS Compliant	Yes

Mechanical Properties:

Max. Recommended Pull Tension	62.4 lbs.
Min. Bend Radius (Install)	1.6"



Specification Issue Date: 7/06

This document is the property of West Penn Wire. The information contained herein is considered Proprietary and not to be reproduced by any means Without written consent of West Penn Wire

Standard Lengths are 1000ft.
The Jacket is sequentially footmarked.
The information presented here is, to the best of our knowledge, is true and accurate. However, since conditions of use are beyond our control, all recommendations or suggestions are presented without guarantee or responsibility on our part. We disclaim all liability in connection with the use of information contained herein or otherwise.



GENESIS SERIES

Power Limited Fire Alarm Cable Part No. 4151

Description: 16 AWG 2/C DIRECT BURIAL FPL
Compliance: UL Standard 13 AND 1424; NEC Article 760

Construction:

Conductor 16 AWG Stranded Bare Copper
No. of Conductors 2

Insulation

Type SRPVC
Color Black, Red
Thickness 0.020" nom.
Diameter 0.096" nom.
Lay Length 5.5" nom.

Jacket

Type PVC
Color Black
Thickness 0.045" nom.
Diameter 0.282" nom.

Legend (Ink Print)

HONEYWELL P/N 4151 E175105 (UL) FPL OR CL2 SUN RES DIR BUR (RoHS)
W/O # XXXXXX-XXX XXXXFT DEVICE/ZONE A B C D E F 1 2 3 4 5 6 7 8 9

Properties

Temperature Rating -20 to 60 °C
Operating Voltage 300 Volts max.
Capacitance 21 pf/ft nom.
Impedance 96 Ohms nom.
DC Resistance 3.9 Ohms/M' at 20°C
Flame Rating UL Vertical Tray

Technical Data Sheet Fire Alarm Cables



2833 West Chestnut Street
Washington, PA 15301
Toll Free: (800) 245-4964
Fax: (724) 222-6420
www.westpenn-wpw.com



PART NUMBER:	60977B
DESCRIPTION:	18/4 Solid bare copper conductors, shielded with an overall jacket.
NEC RATING:	FPLP, NEC Article 760
APPROVALS:	(UL) or (ETL)us Listed
APPLICATION:	Indoor within ducts, plenums, and other spaces used for environmental air for (Audio Circuits, Control Circuits, Initiating Circuits, Notification Circuits)

Construction Parameters:

Conductor	18 AWG Bare Copper
Stranding	Solid
Insulation Material	Polymer Alloy
Insulation Thickness	0.010" Nom.
Number of Conductors	4
Shield	100% Aluminum Polyester Foil
Drain	Stranded Tinned Copper
Jacket Material	Flexible Plenum
Jacket Thickness	0.015" Nom.
Overall Cable Diameter	0.148" Nom.
Approximate Cable Weight	36 Lbs/1M' Nom.
Flame Rating	NFPA- 262 Flame Test

Electrical & Environmental Properties:

Temperature Rating	-10deg C to 60deg C
Operating Voltage	300 V RMS
Max.Capacitance Between Conductors @ 1 KHz	54 pf/ft Nom.
Capacitance Between Conductors to Shield @ 1 KHz	97 pf/ft Nom.
DC Resistance per Conductor @ 20deg C	6.5 Ohms/1M' Nom.
Insulation Colors	Black, Red, Brown, Blue
Jacket Color	Red
RoHS Compliant	--

Mechanical Properties:

Max. Recommended Pull Tension	104 lbs.
Min. Bend Radius (Install)	1.7"

Specification Issue Date: 7/06

This document is the property of West Penn Wire.
The information contained herein is considered
Proprietary and not to be reproduced by any means
Without written consent of West Penn Wire

Cold Environment Precautions: Due to the nature of PVC Compounds to become non-pliable when stored or handled in ambient temperatures of 32 deg. F or less, we recommend the following:

"Prior to installation, condition the cable for at least 24 hours at room temperature to provide the best flex properties for ease of installation."

Standard Lengths are 1000ft.
The Jacket is sequentially footmarked.
The information presented here is, to the best of our knowledge, is true and accurate. However, since conditions of use are beyond our control, all recommendations or suggestions are presented without guarantee or responsibility on our part. We disclaim all liability in connection with the use of information contained herein or otherwise.

Technical Data Sheet Fire Alarm Cables

WEST PENN WIRE



2833 West Chestnut Street
Washington, PA 15301
Toll Free: (800) 245-4964
Fax: (724) 222-6420
www.westpenn-wpw.com

PART NUMBER:	60993B
DESCRIPTION:	14/2 Solid bare copper conductors, unshielded with an overall jacket.
NEC RATING:	FPLP, NEC Article 760
APPROVALS:	(UL) or (ETL)us Listed
APPLICATION:	Indoor within ducts, plenums, and other spaces used for environmental air for (Audio Circuits, Control Circuits, Initiating Circuits, Notification Circuits)

Construction Parameters:

Conductor	14 AWG Bare Copper
Stranding	Solid
Insulation Material	Polymer Alloy
Insulation Thickness	0.012" Nom.
Number of Conductors	2 (1 Pair)
Shield	None
Drain	None
Jacket Material	Flexible Plenum
Jacket Thickness	0.015" Nom.
Overall Cable Diameter	0.191" Nom.
Approximate Cable Weight	36 Lbs/1M' Nom.
Flame Rating	NFPA- 262 Flame Test

Electrical & Environmental Properties:

Temperature Rating	-10deg C to 60deg C
Operating Voltage	300 V RMS
Max.Capacitance Between Conductors @ 1 KHz	34 pf/ft Nom.
DC Resistance per Conductor @ 20deg C	2.6 Ohms/1M' Nom.
Insulation Colors	Black, Red
Jacket Color	Red
RoHS Compliant	Yes

Mechanical Properties:

Max. Recommended Pull Tension	99.4 lbs.
Min. Bend Radius (Install)	1.9"

Specification Issue Date: 7/06

This document is the property of West Penn Wire. The information contained herein is considered Proprietary and not to be reproduced by any means Without written consent of West Penn Wire

Cold Environment Precautions: Due to the nature of PVC Compounds to become non-pliable when stored or handled in ambient temperatures of 32 deg. F or less, we recommend the following:

"Prior to installation, condition the cable for at least 24 hours at room temperature to provide the best flex properties for ease of installation."

Standard Lengths are 1000ft.

The Jacket is sequentially footmarked.

The information presented here is, to the best of our knowledge, is true and accurate. However, since conditions of use are beyond our control, all recommendations or suggestions are presented without guarantee or responsibility on our part. We disclaim all liability in connection with the use of information contained herein or otherwise.