

DETAIL 7 NOT USED

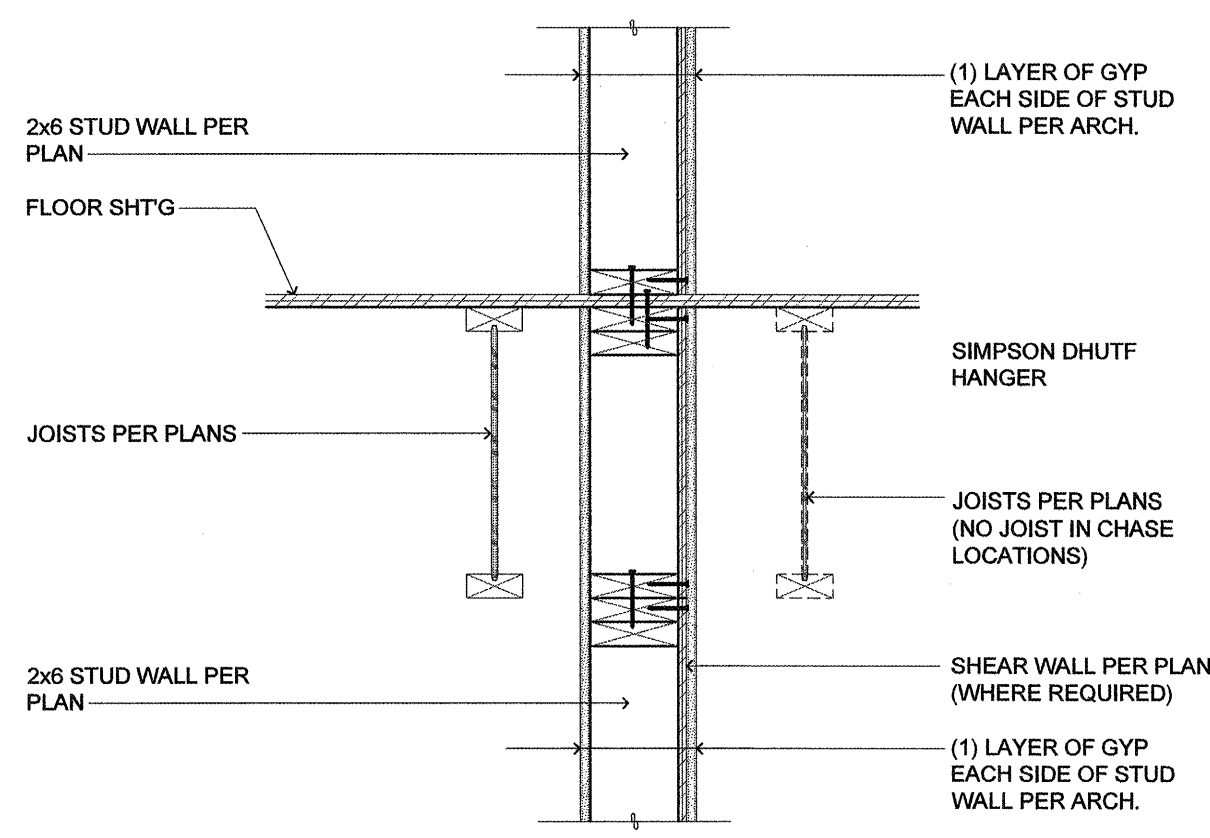

16 1 HOUR SEPARATION (NON-LOAD BEARING PARALLEL TO WALL) SCALE: 1" = 1'-0"

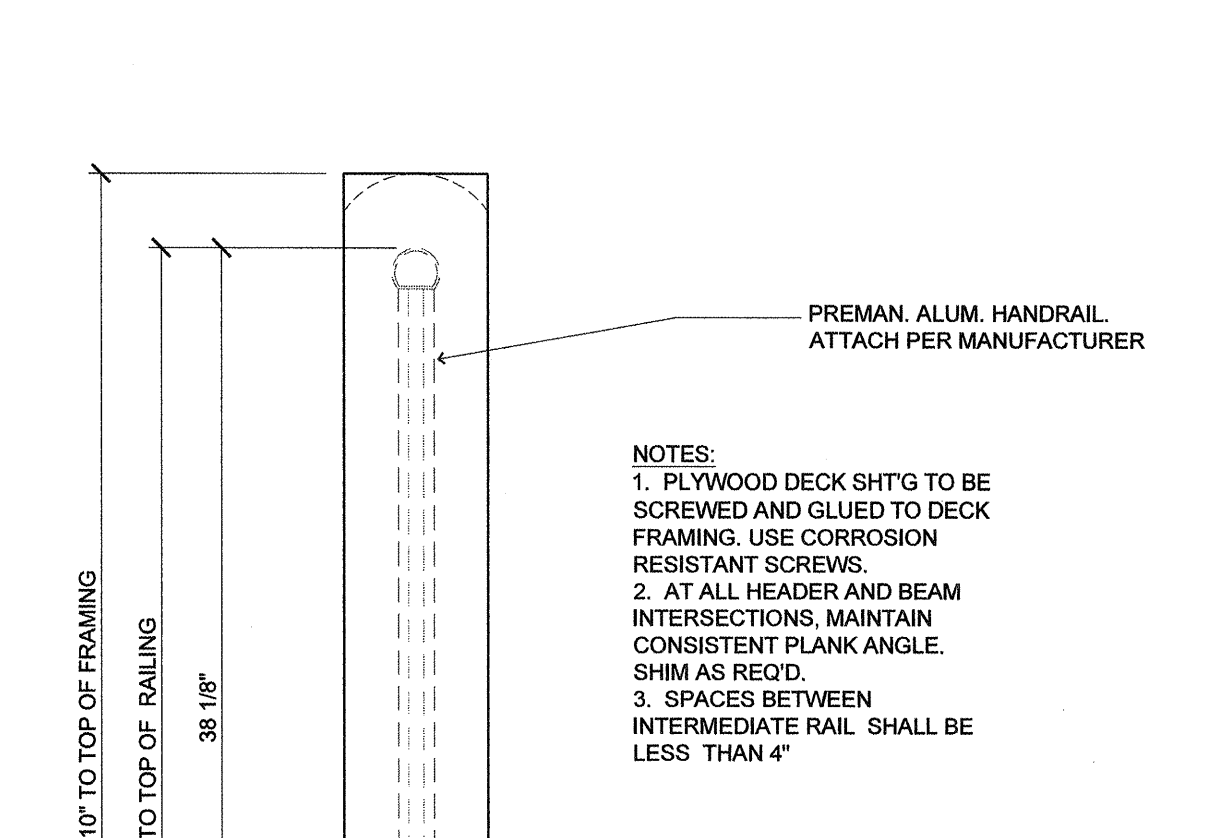

14 60 MIL SHEET VINYL DECK SYSTEM TAPERED I-JOIST PER PLAN 3/4" PLYWD. SHT'G

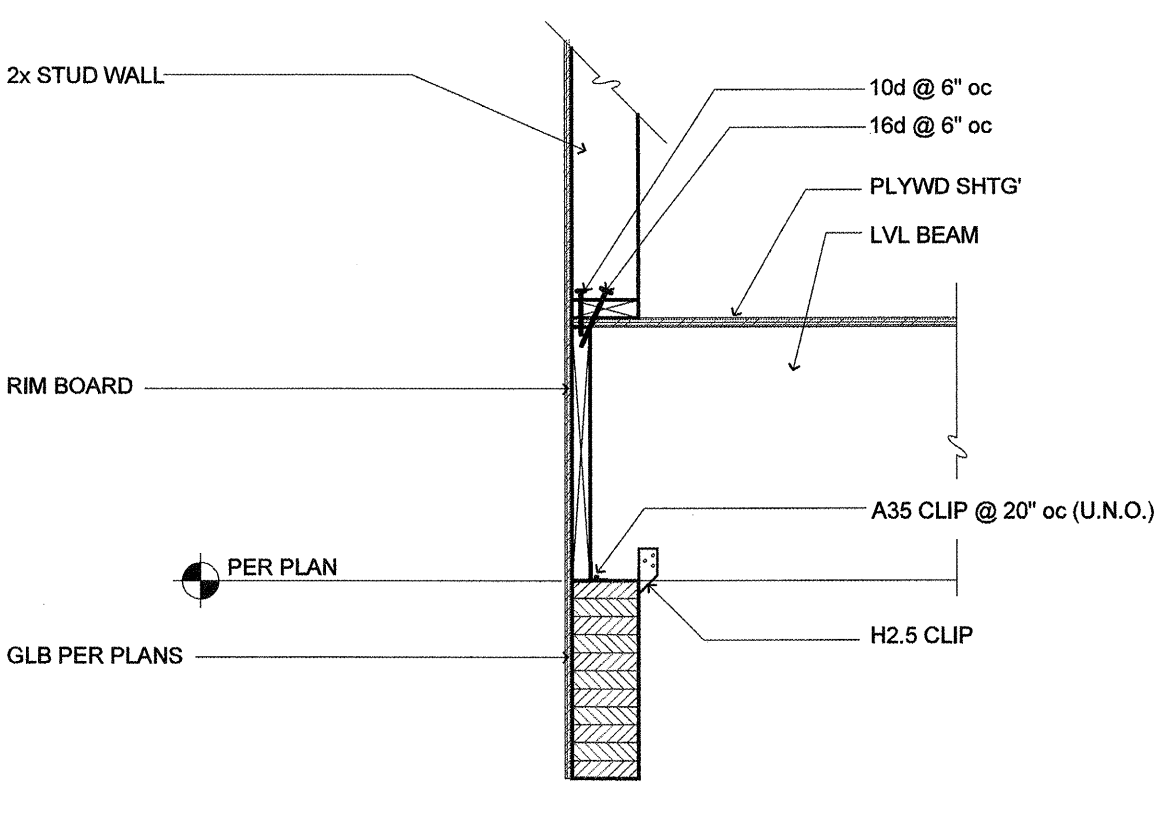

9 CONNECTION DETAIL SCALE: 3/4" = 1'-0"

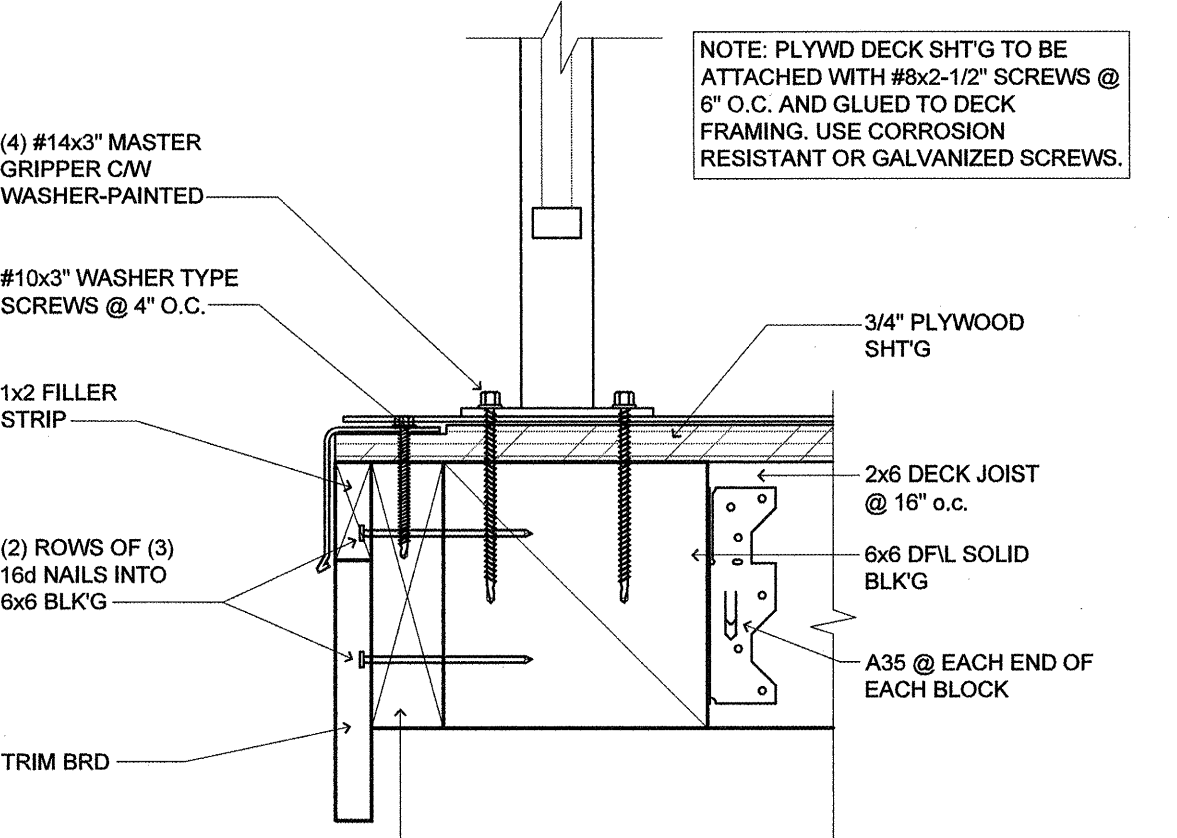

4 DECK FRAMING (DECK EDGE) SCALE: 3" = 1'-0"

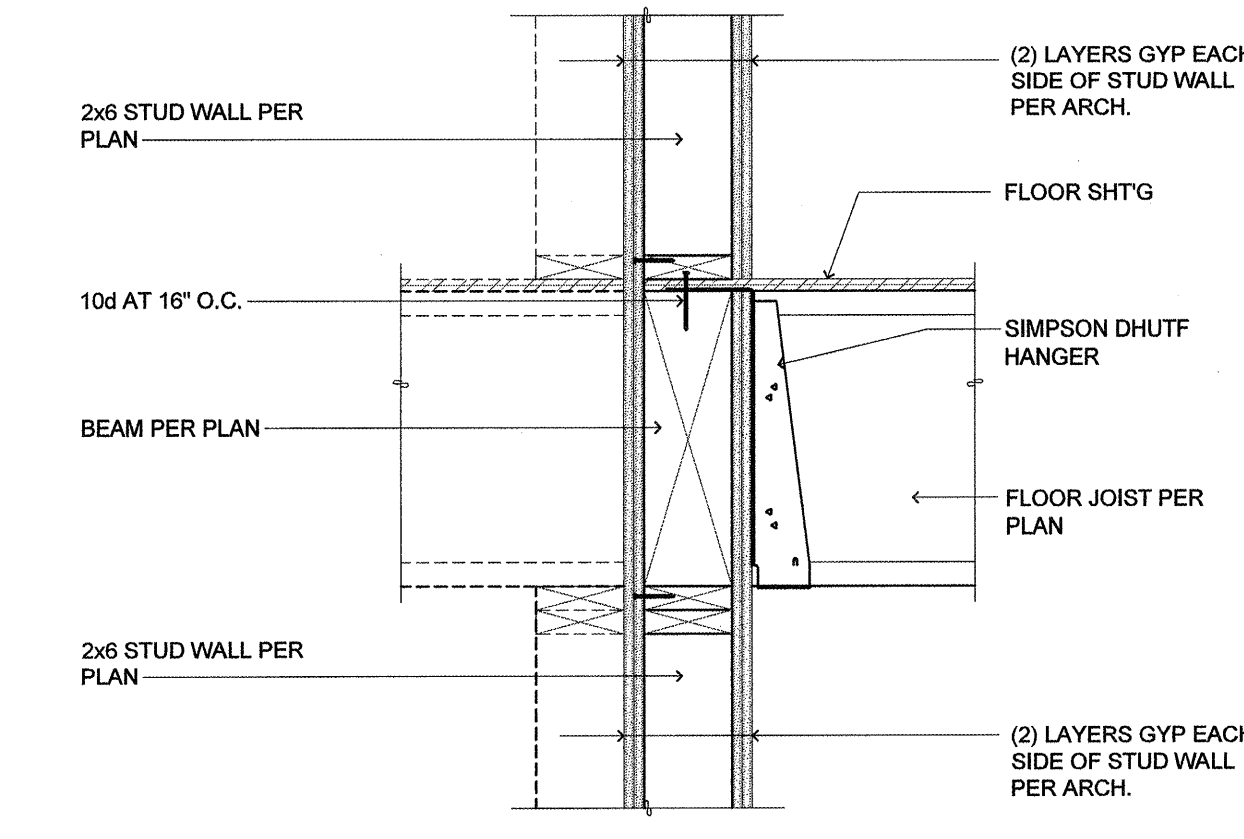

19 2 HOUR SEPARATION (LOAD BEARING) SCALE: 1" = 1'-0"

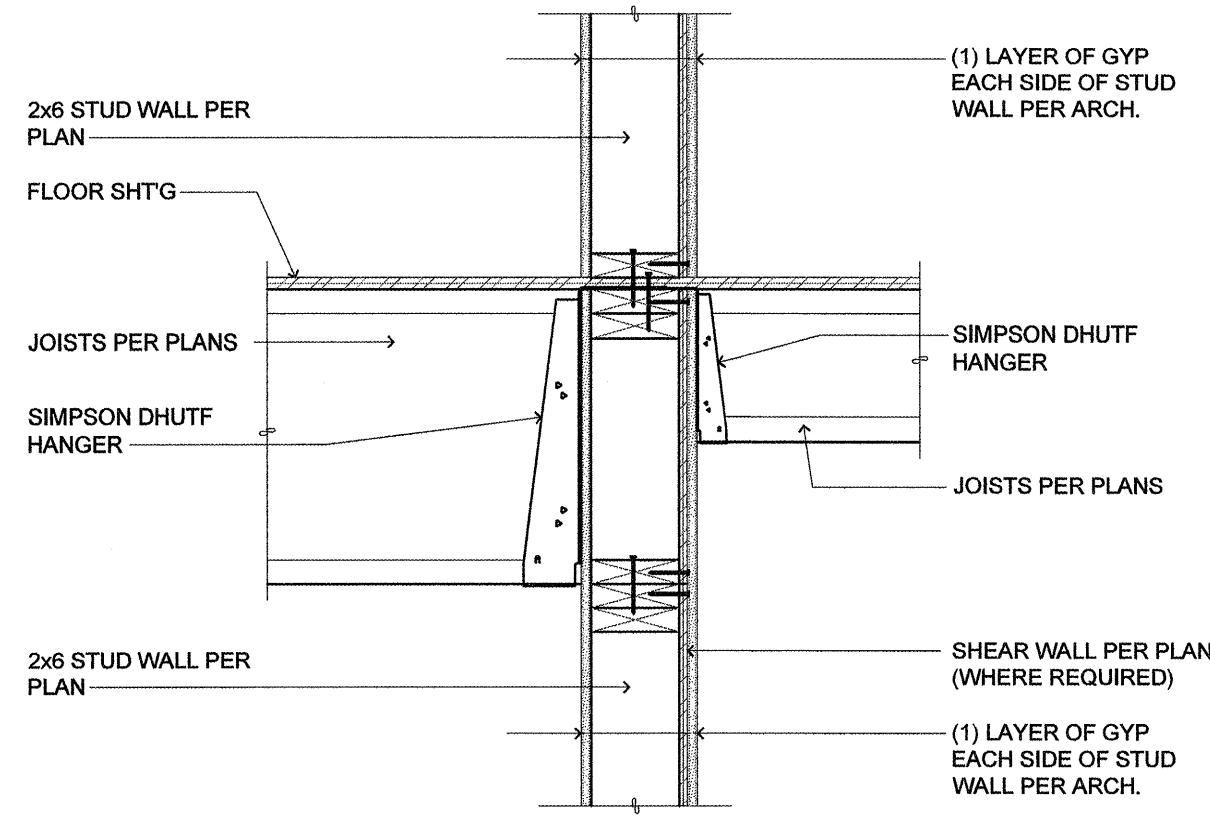

15 1 HOUR SEPARATION (LOAD BEARING PERP. TO JOIST) SCALE: 1" = 1'-0"

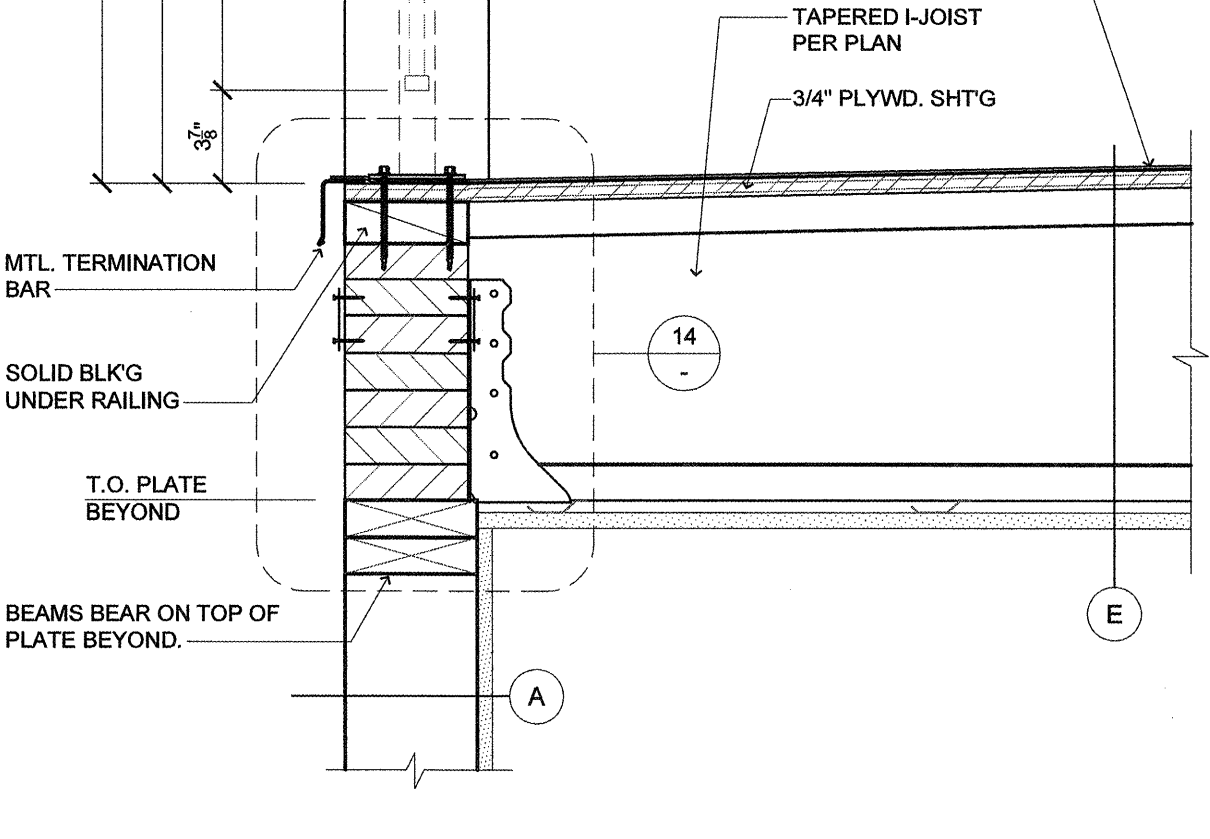

12 DECK DETAIL (DECK EDGE & BEAM) SCALE: 1 1/2" = 1'-0"

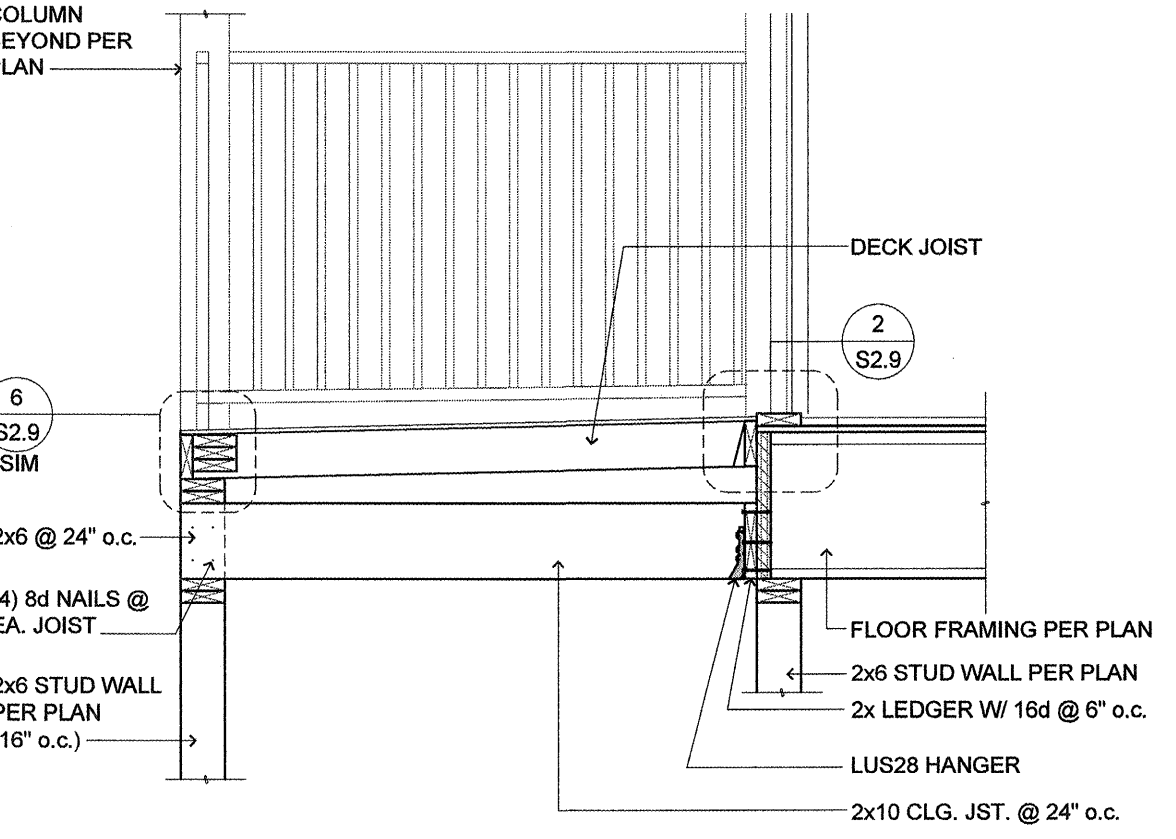

8 DECK FRAMING (ABOVE HVAC/ELEV. EQ. RM.) SCALE: 1/2" = 1'-0"

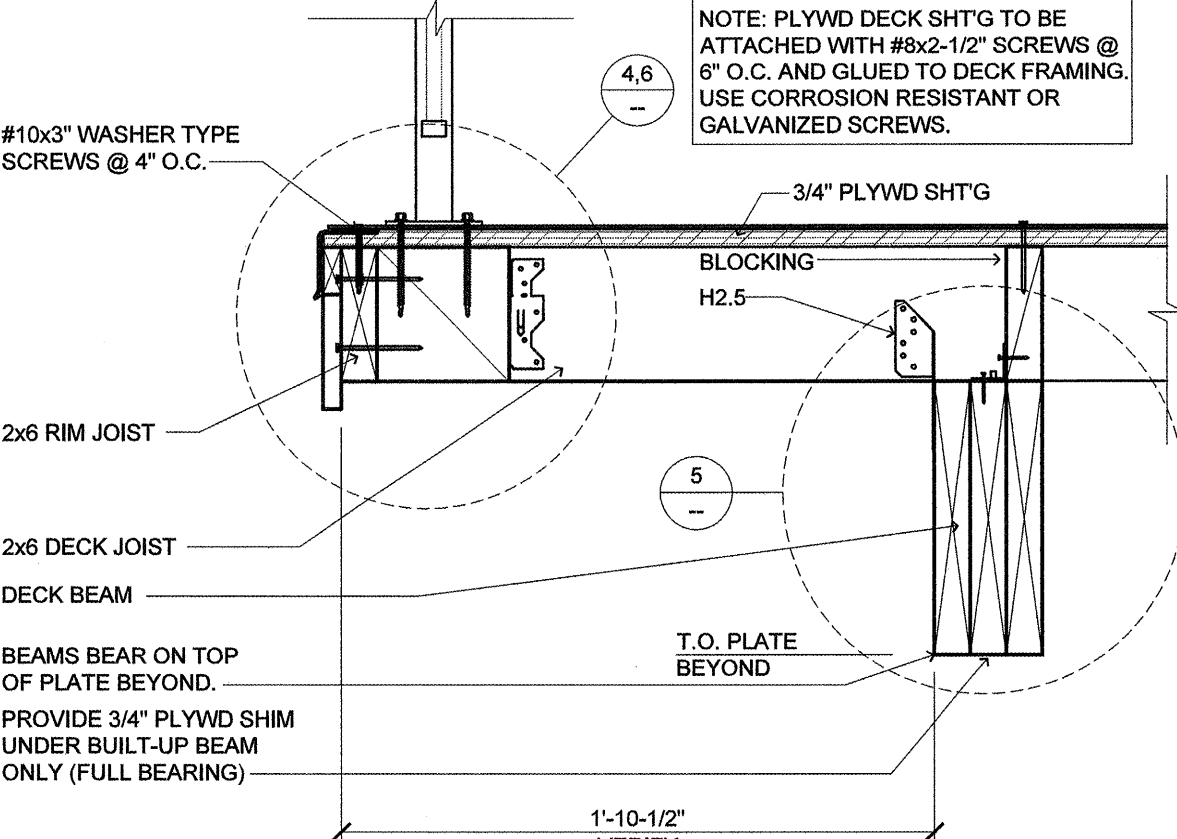

3 DECK FRAMING (DECK EDGE) SCALE: 1 1/2" = 1'-0"

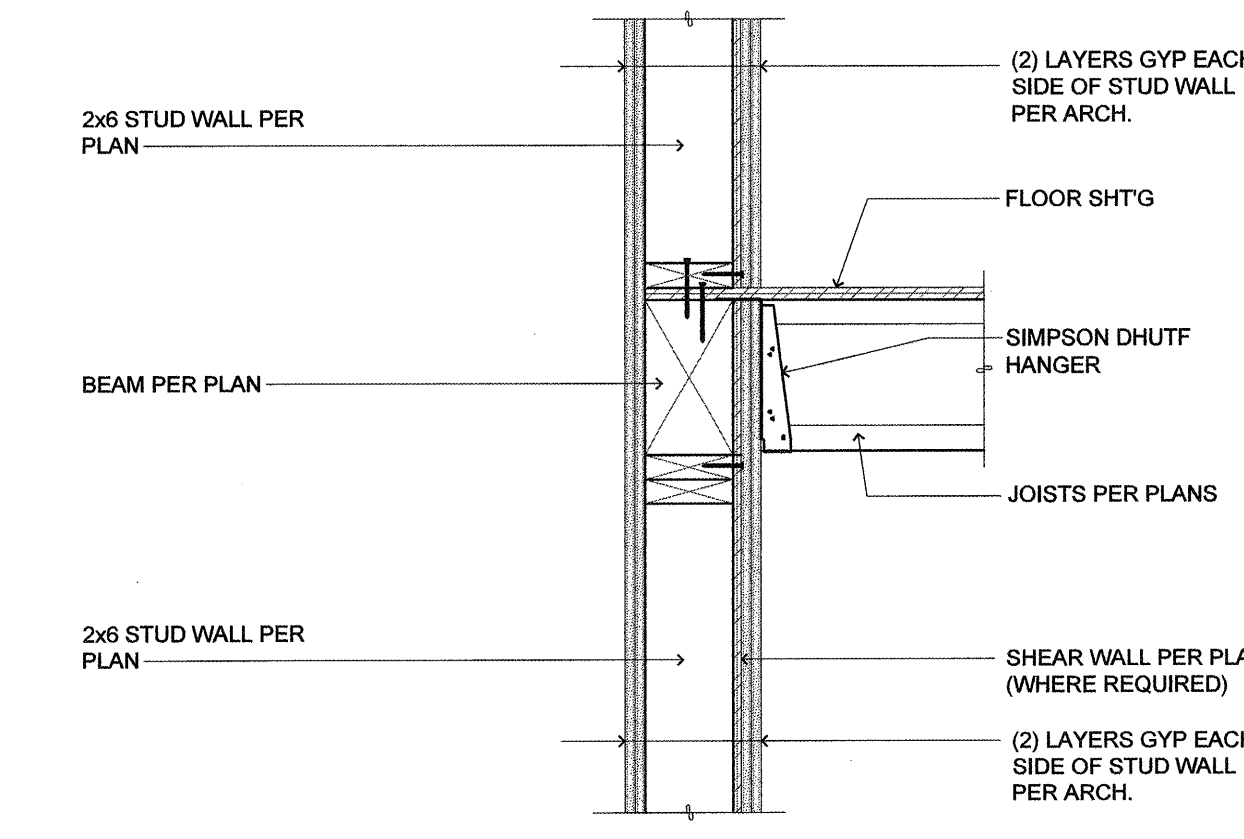

18 2 HOUR SEPARATION (LOAD BEARING - AT MIDLANDING) SCALE: 1" = 1'-0"

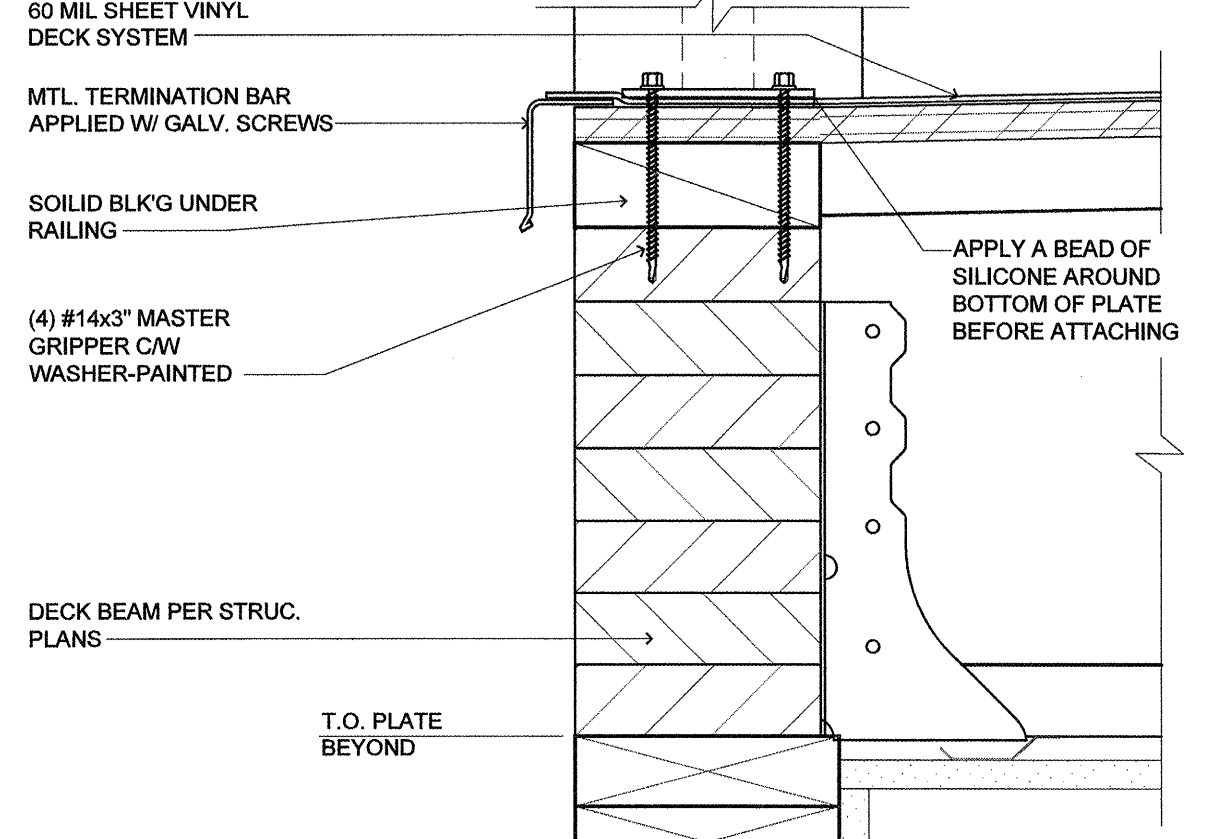

14 DECK DETAIL (DECK BEAM) SCALE: 1'-0" = 1'-0"

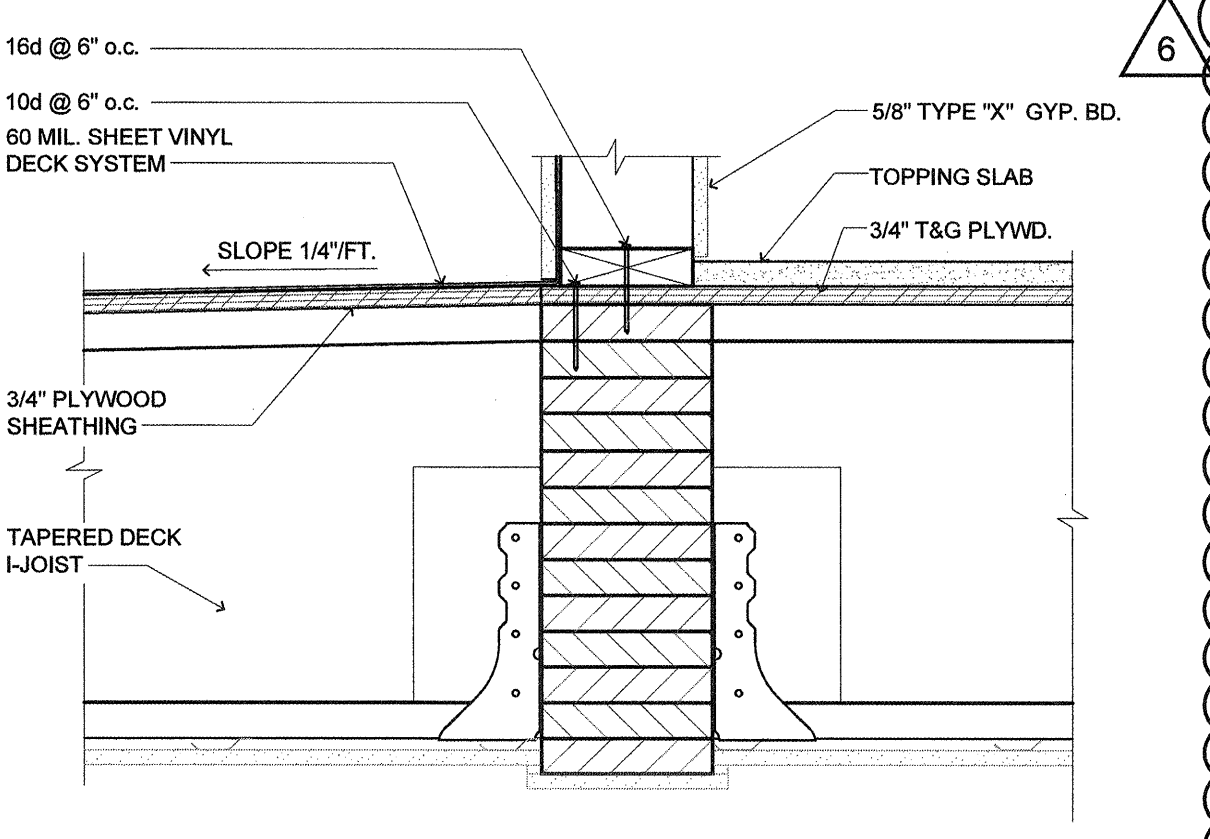

11 DECK-WALL INTERSECTION (SOFFIT ON UNDERSIDE OF DECK) SCALE: 1 1/2" = 1'-0"

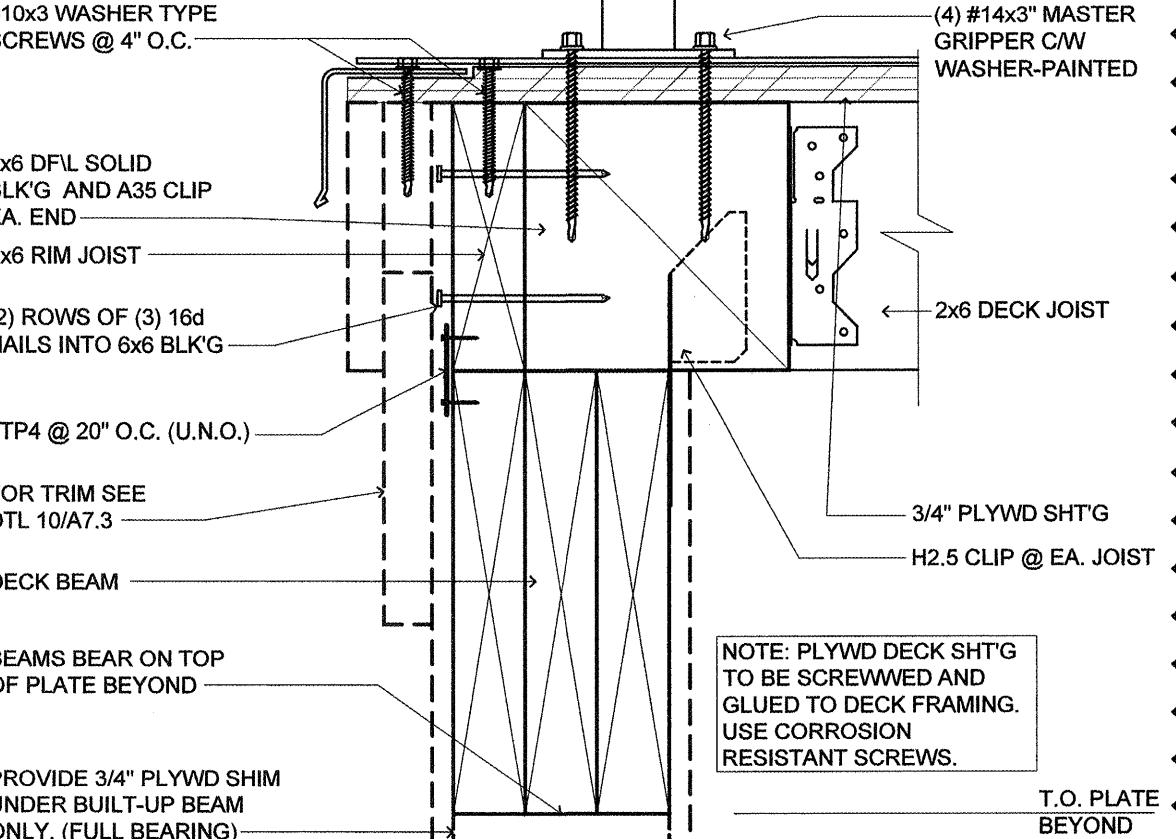

6 DECK FRAMING (DECK BEAM) SCALE: 3" = 1'-0"

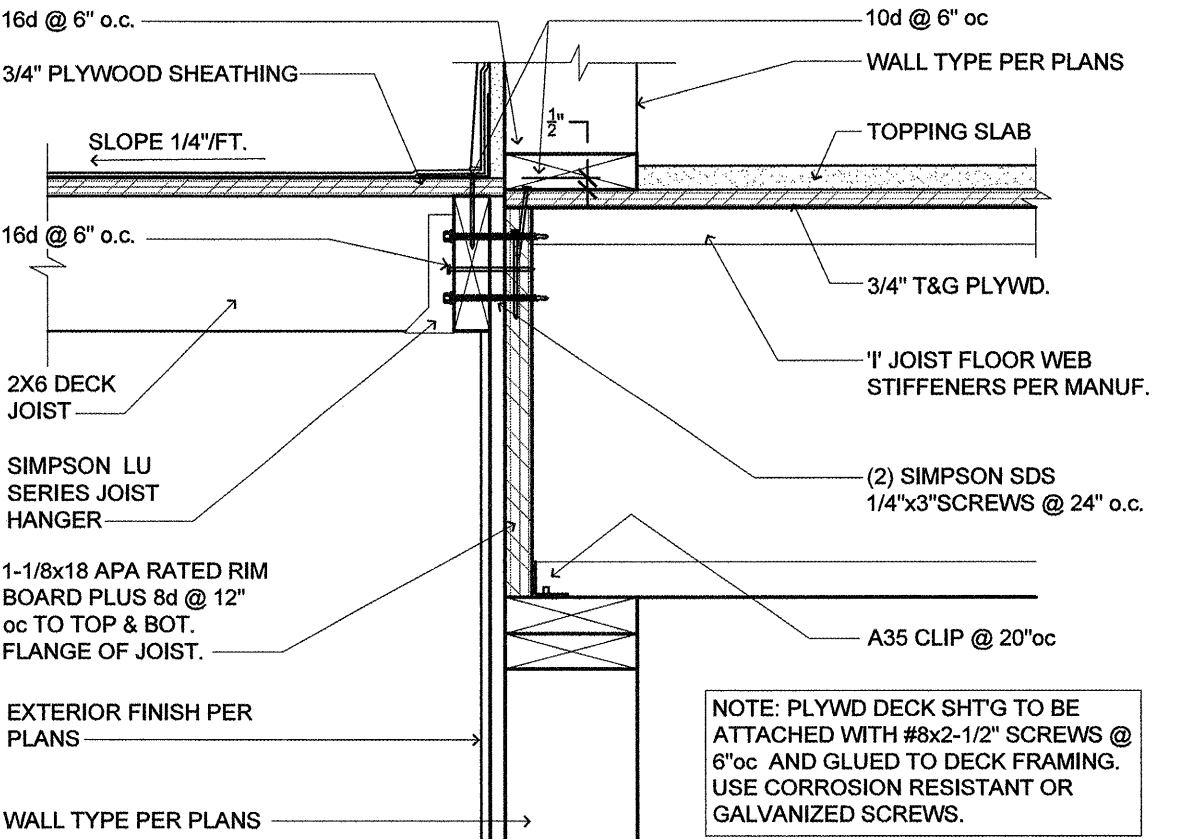

2 DECK FRAMING (DECK-WALL INTERSECTION) SCALE: 1 1/2" = 1'-0"

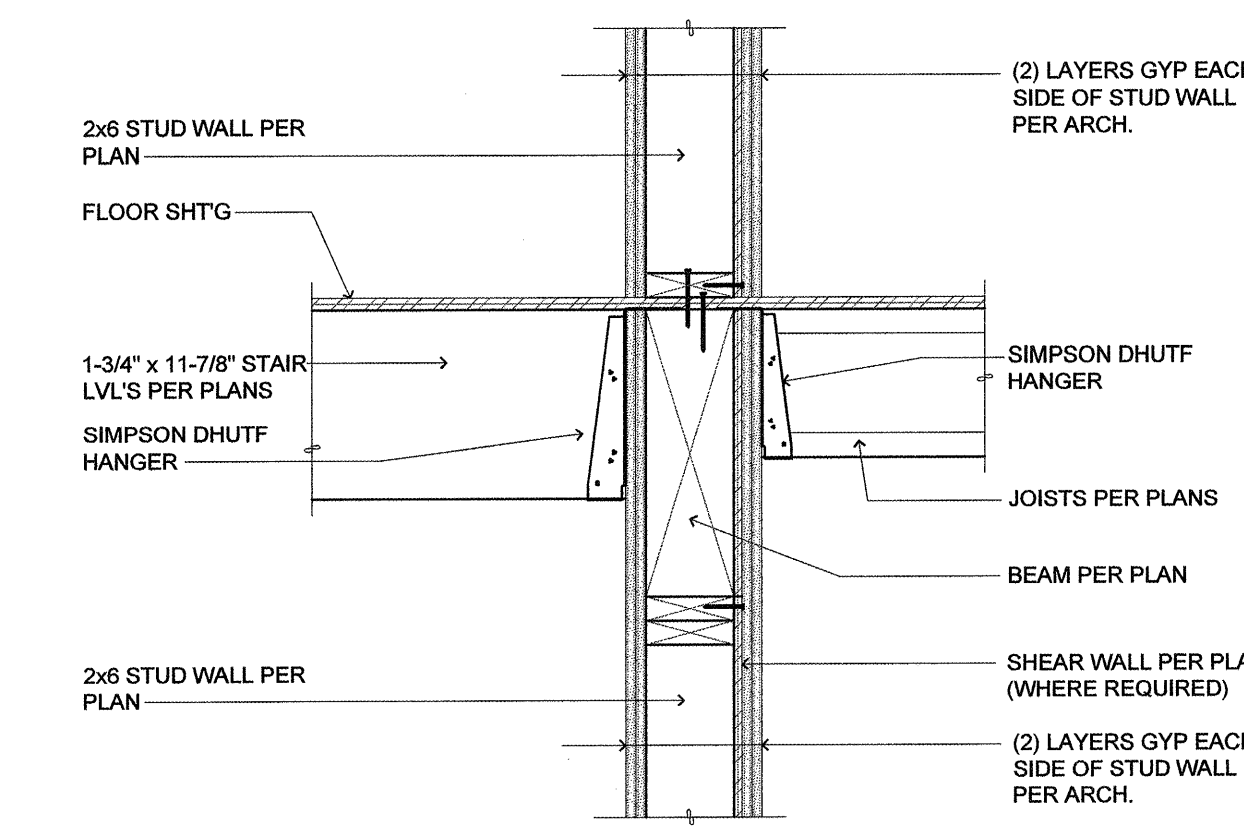

17 2 HOUR SEPARATION (LOAD BEARING PERP. TO JOIST) SCALE: 1" = 1'-0"

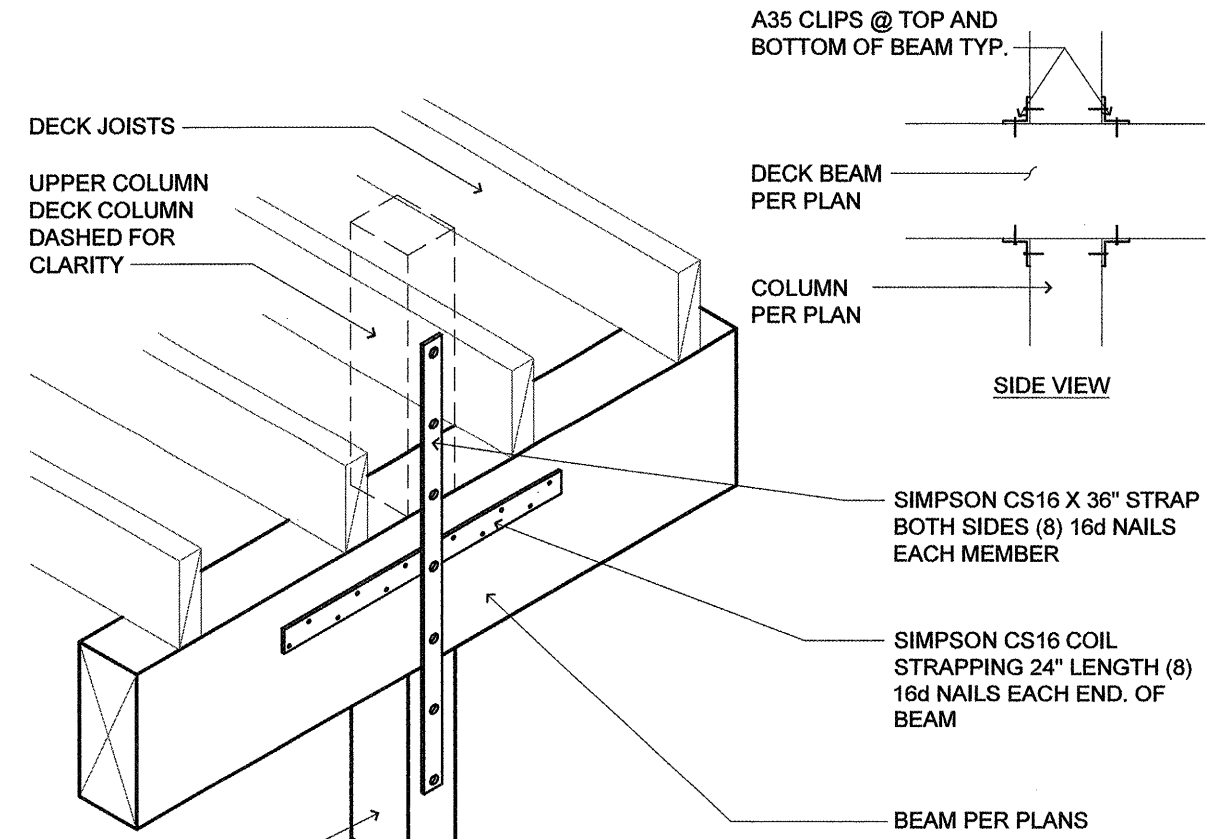

13 DECK BEAM/COLUMN INTERSECTION (TYPICAL OF WING END UNITS) SCALE: N.T.S.

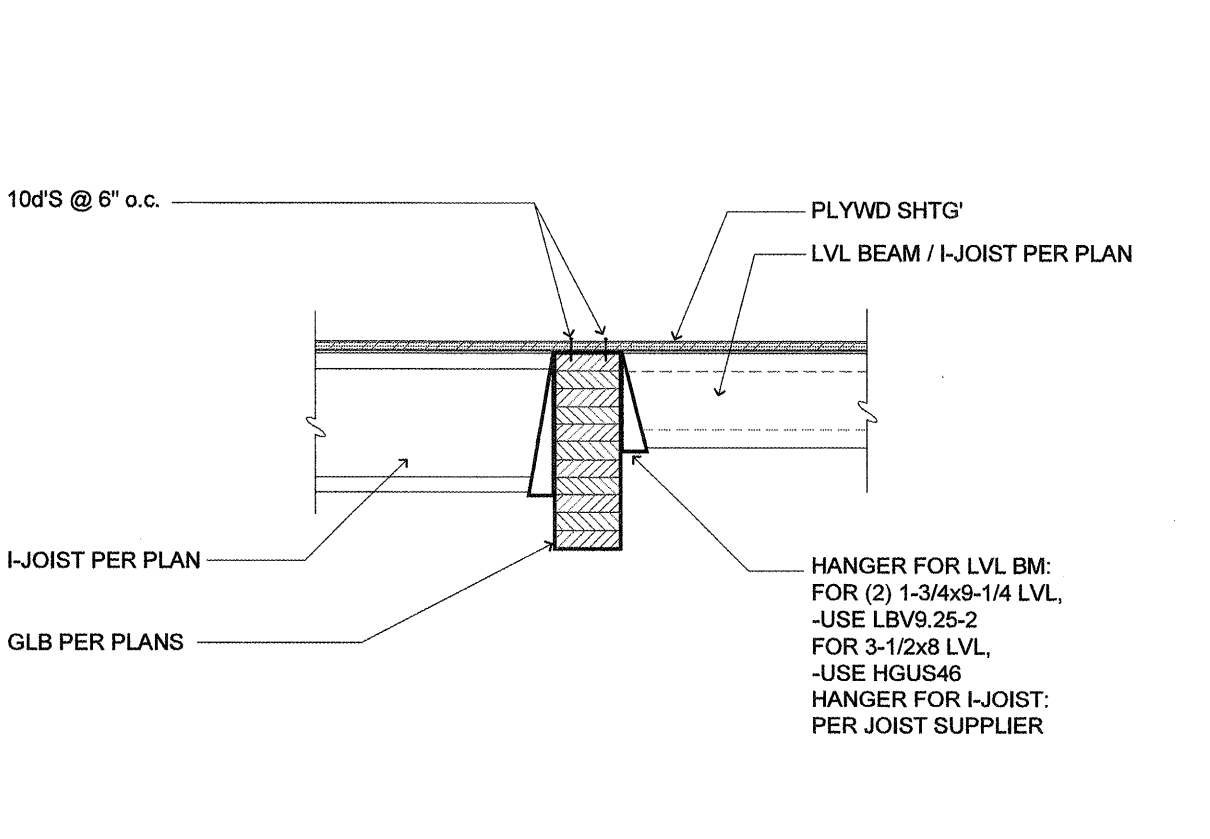

10 CONNECTION DETAIL (JOIST TO BEAM) SCALE: 3/4" = 1'-0"

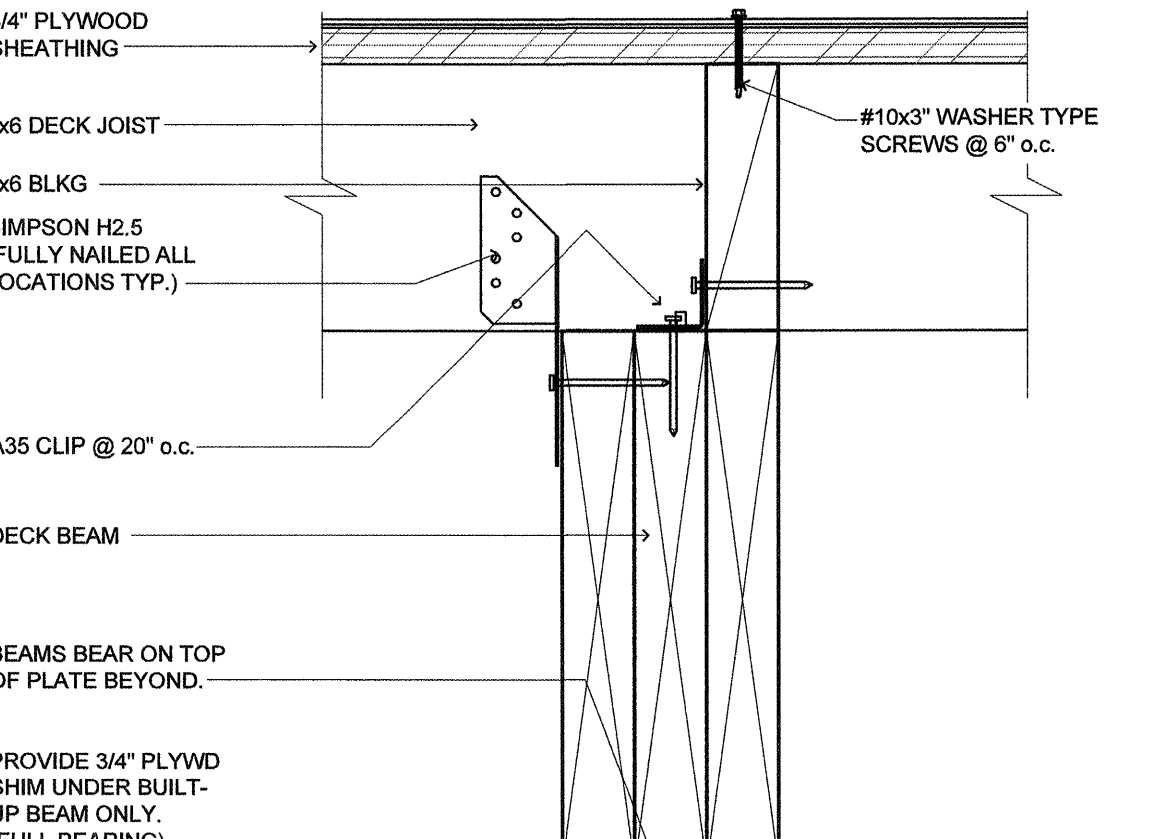

5 DECK FRAMING (DECK BEAM) SCALE: 3" = 1'-0"

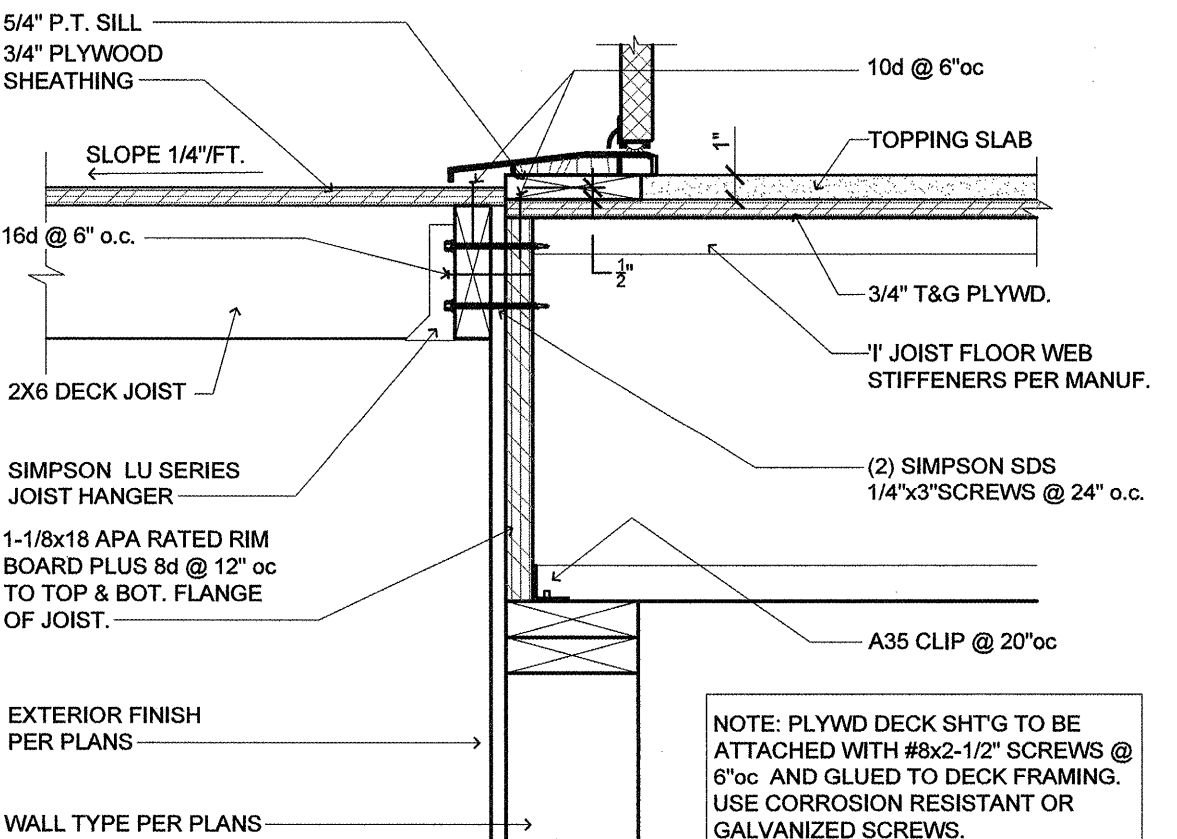

1 DECK FRAMING (DECK AT THRESHOLD) SCALE: 1 1/2" = 1'-0"

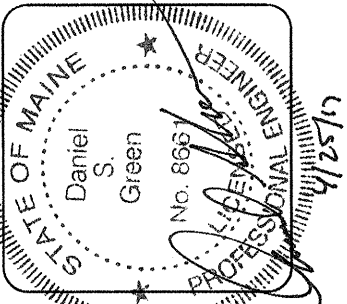

lenity architecture
3150 Keitt Court, SE, Salem, Oregon 97302
P: 503.399.1090 F: 503.399.0565

COLSON AND COLSON
GENERAL CONTRACTOR, INC.
2280 McILCHRIST STREET, SUITE 200
SALEM, OREGON, 97302
PHONE (503) 586-7401

PORTLAND
RETIREMENT RESIDENCE
802 OCEAN AVE. PORTLAND, MAINE 04103

DECK AND FRAMING DETAILS

DATE: 8/28/2015
REVISED DATE:

SHEET S2.9

6/31/2017