

**lenity**  
architecture  
350 Kettle Court SE, Salem, Oregon 97301  
P: 503.399.1090 F: 503.399.0565  
W: lenityarchitecture.com

**COLSON AND COLSON**  
GENERAL CONTRACTOR, INC.  
2260 MCGILCHRIST STREET SE, SUITE 200  
SALEM, OREGON, 97302  
PHONE (503) 586-7401

**PORTLAND**  
RETIREMENT RESIDENCE  
802 OCEAN AVE. PORTLAND, MAINE 04103

**FIRE RATED**  
CONSTRUCTION  
DETAILS

DATE: 8/28/2015  
REVISED DATE: 9/22/2015, 2/2/2016  
SHEET: A8.8

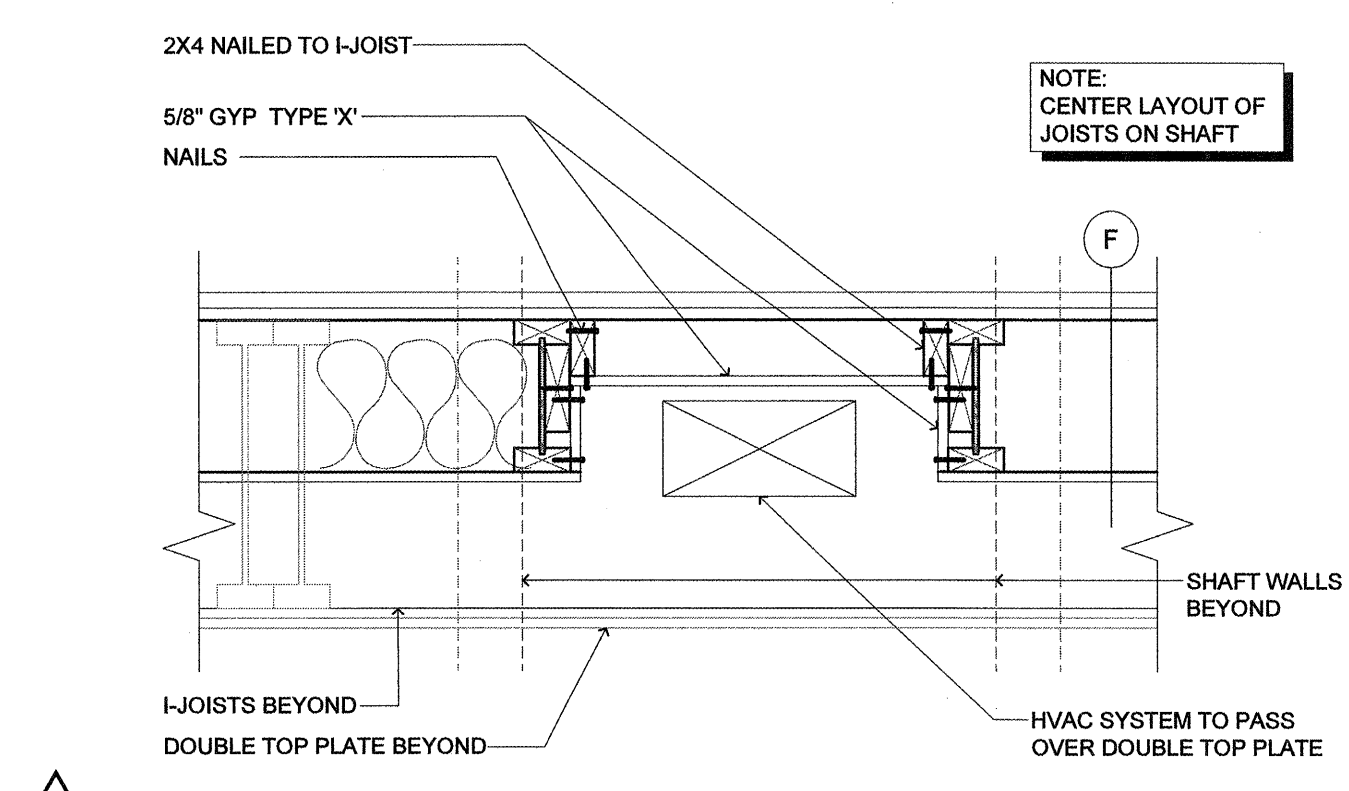

**11** HVAC ABOVE DOUBLE TOP PLATE  
(TRANSFER FROM SHAFT TO CORRIDOR)  
SCALE: 1" = 1'-0"

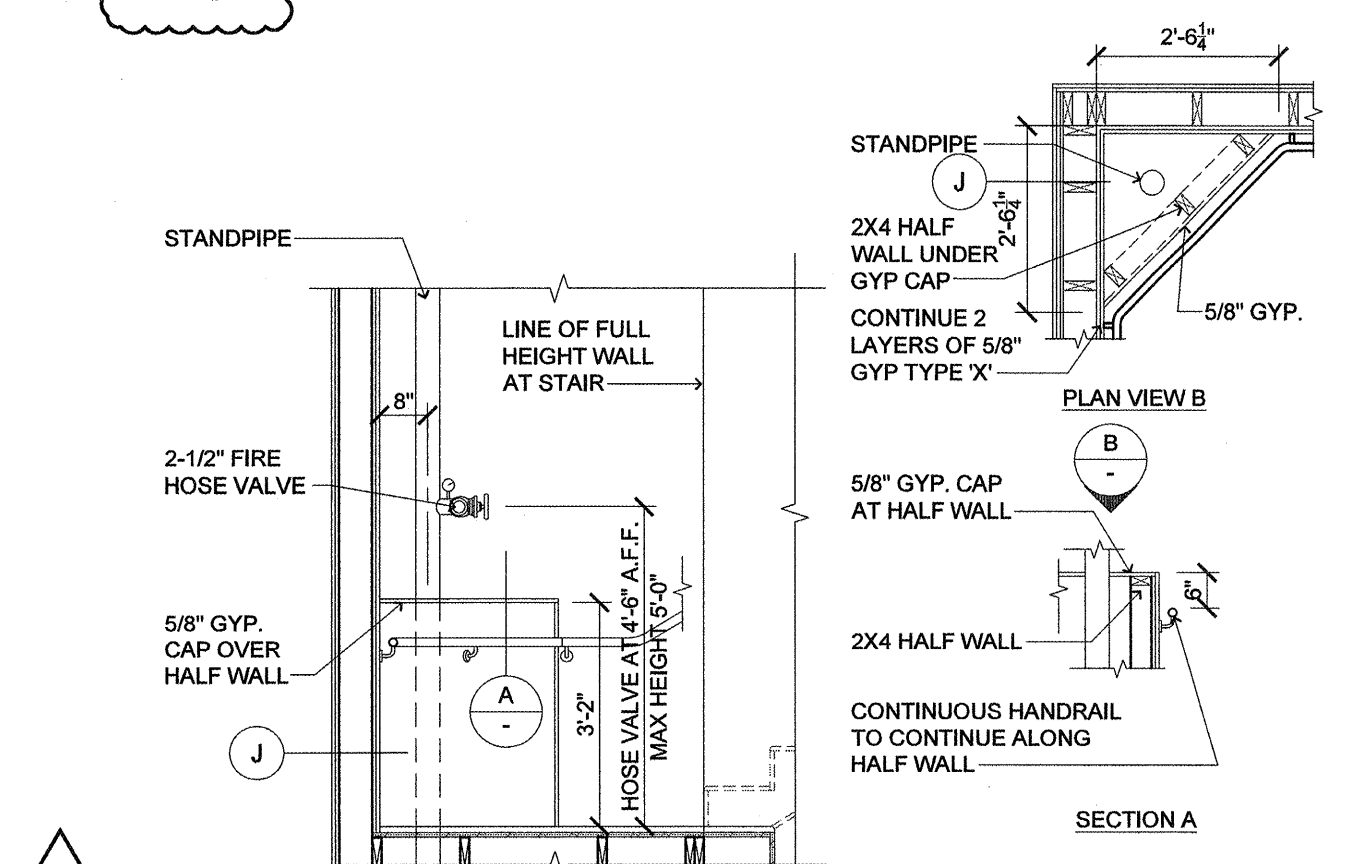

**10** STANDPIPE HALF WALL  
(AT 2 HOUR STAIRS)  
SCALE: 3/8" = 1'-0"

**ALLOWABLE HOLES CHART**

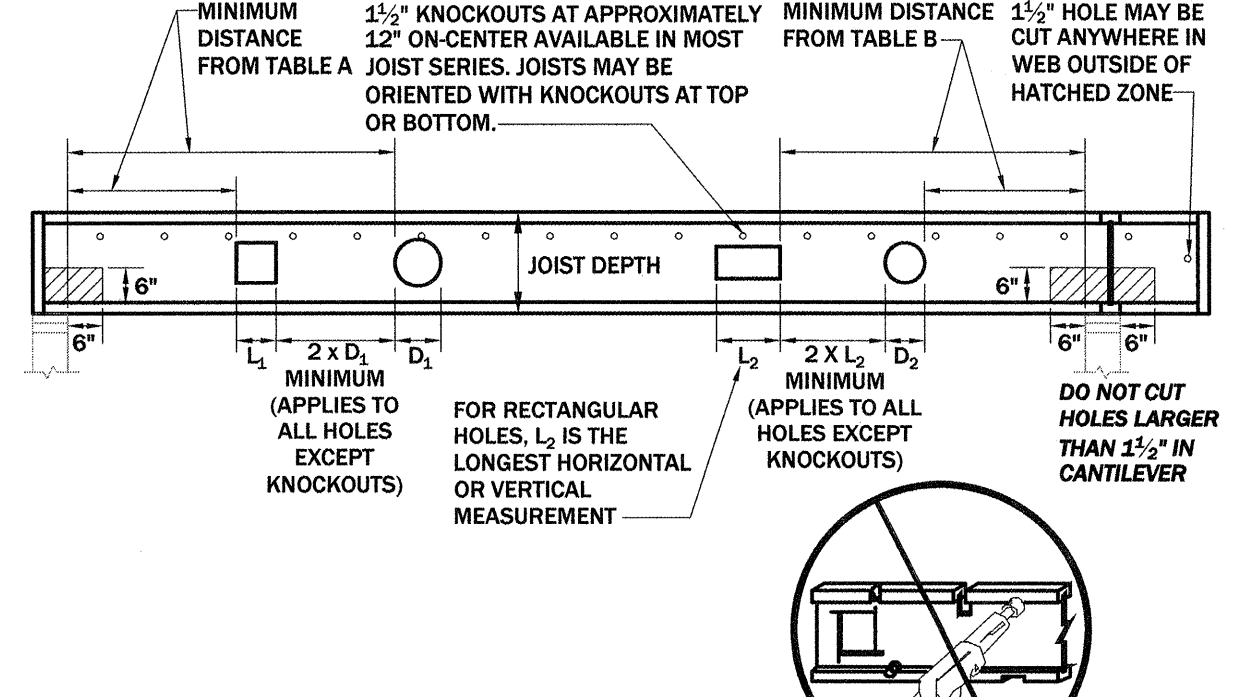

**Table A - End Support**  
Minimum distance from edge of hole to inside face of nearest end support

Joist Depth	Joist Series	Round Hole Size									
		2"	4"	6"	8"	10"	12"	14"	16"	18"	20"
9 1/2"	I45 / I65	1'-6"	2'-0"	2'-6"	3'-0"	-	-	-	-	-	-
		1'-0"	1'-0"	2'-6"	3'-0"	-	-	-	-	-	-
18"	I90 / I90H	1'-0"	1'-0"	2'-6"	3'-0"	4'-0"	4'-6"	5'-0"	5'-6"	6'-0"	6'-6"
		1'-0"	1'-0"	2'-6"	3'-0"	4'-0"	4'-6"	5'-0"	5'-6"	6'-0"	6'-6"

**Table B - Intermediate or Cantilever Support**  
Minimum distance from edge of hole to inside face of nearest intermediate or cantilever support

Joist Depth	Joist Series	Round Hole Size									
		2"	4"	6"	8"	10"	12"	14"	16"	18"	20"
9 1/2"	I45 / I65	1'-6"	2'-0"	2'-6"	3'-0"	-	-	-	-	-	-
		1'-0"	1'-0"	2'-6"	3'-0"	-	-	-	-	-	-
18"	I90 / I90H	1'-0"	1'-0"	2'-6"	3'-0"	4'-0"	4'-6"	5'-0"	5'-6"	6'-0"	6'-6"
		1'-0"	1'-0"	2'-6"	3'-0"	4'-0"	4'-6"	5'-0"	5'-6"	6'-0"	6'-6"

**9** INSTALLATION DETAIL  
(I-JOIST ALLOWABLE HOLE CHART)  
SCALE: NOT TO SCALE

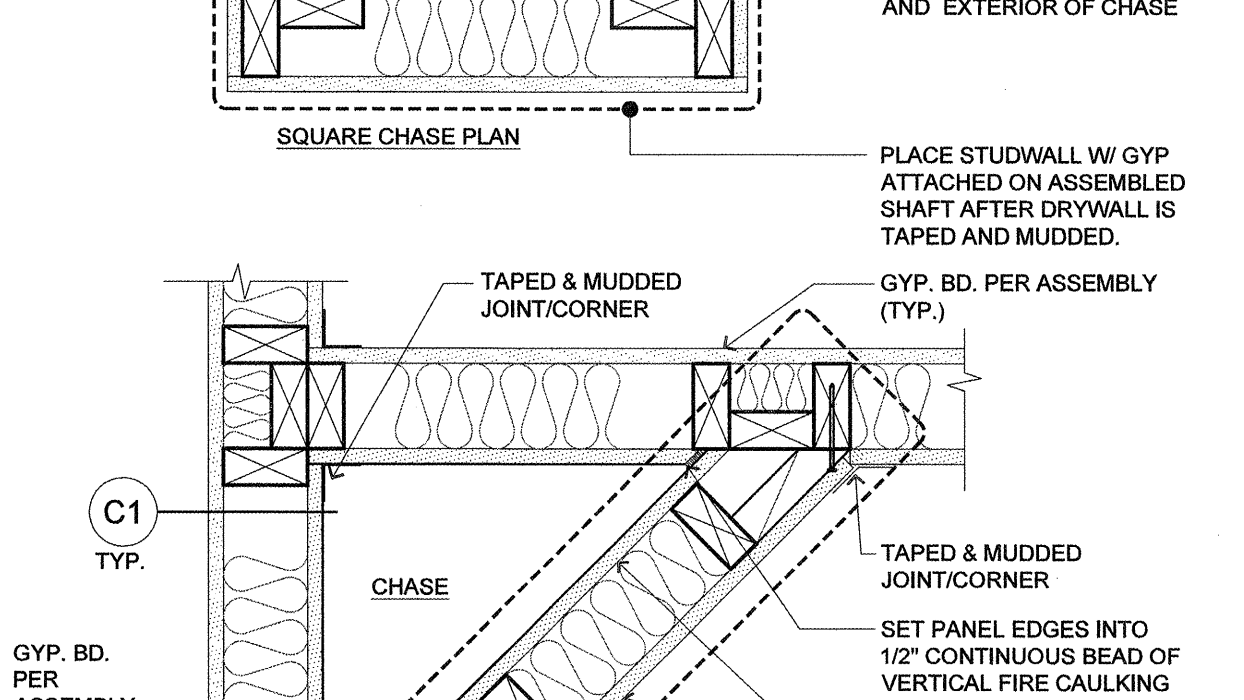
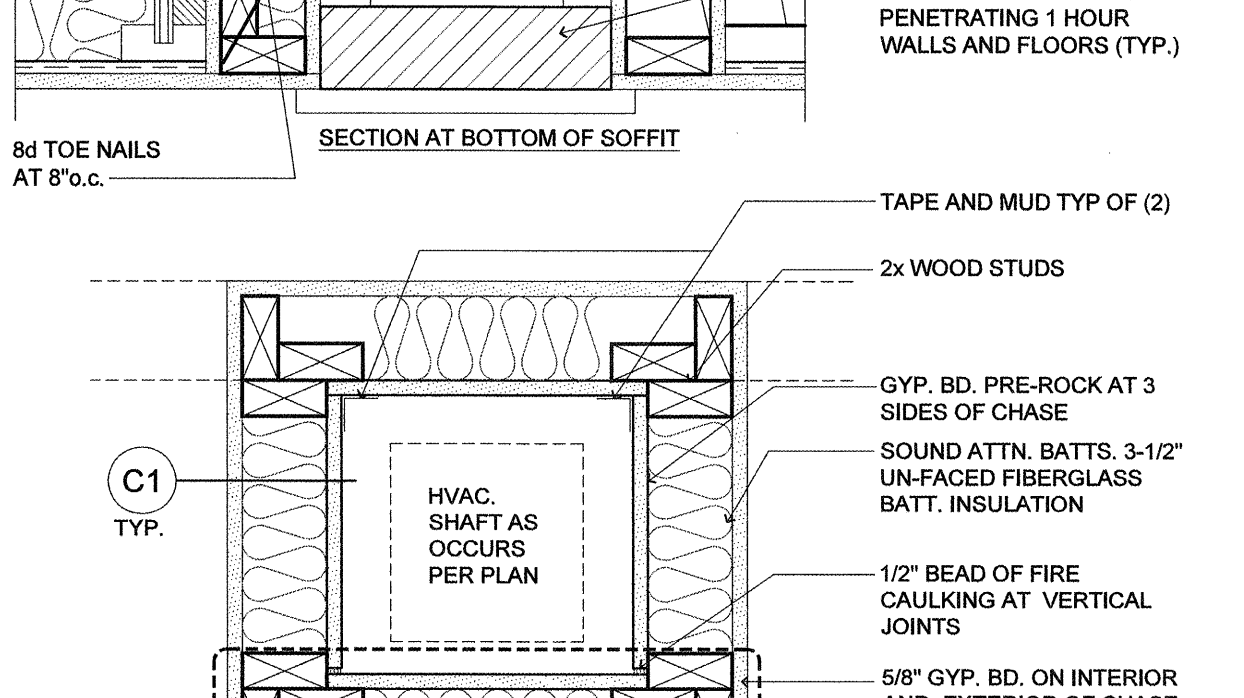
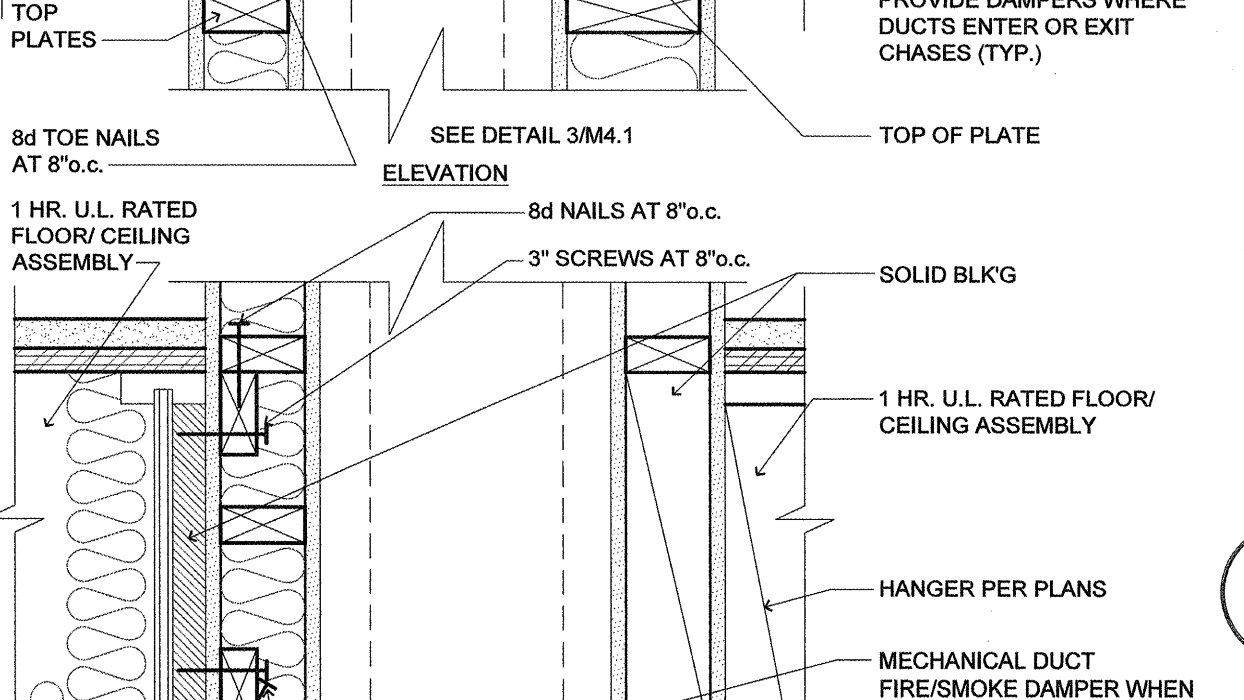
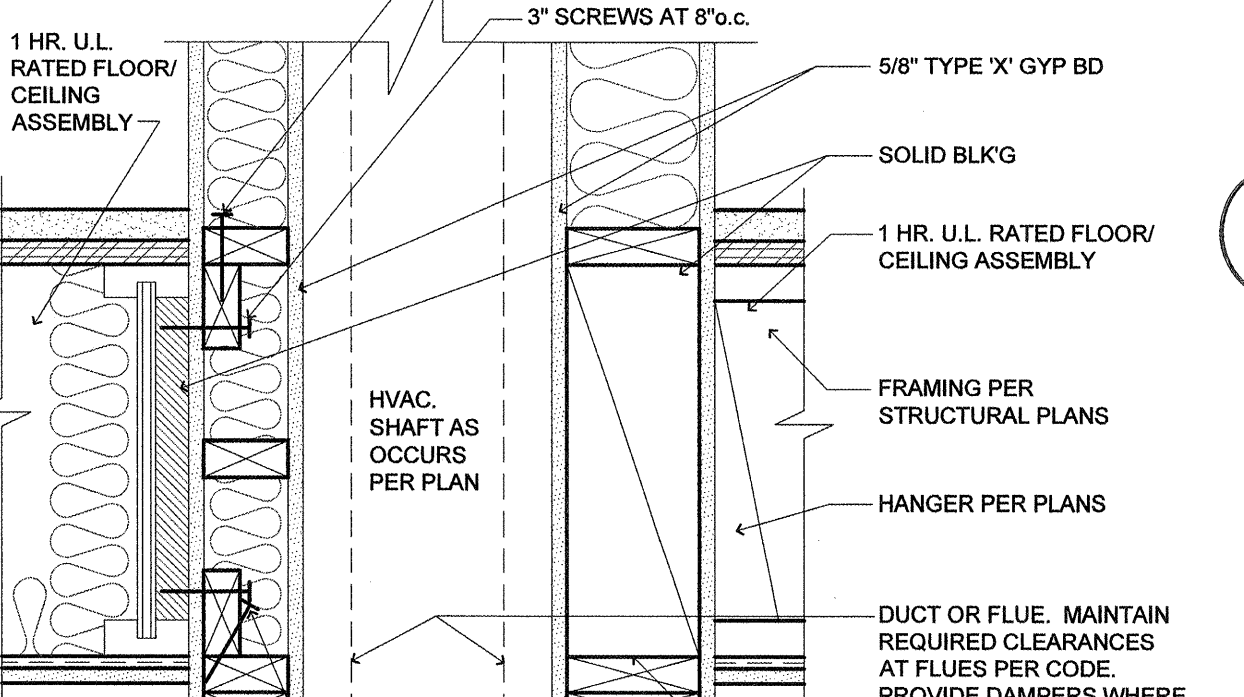
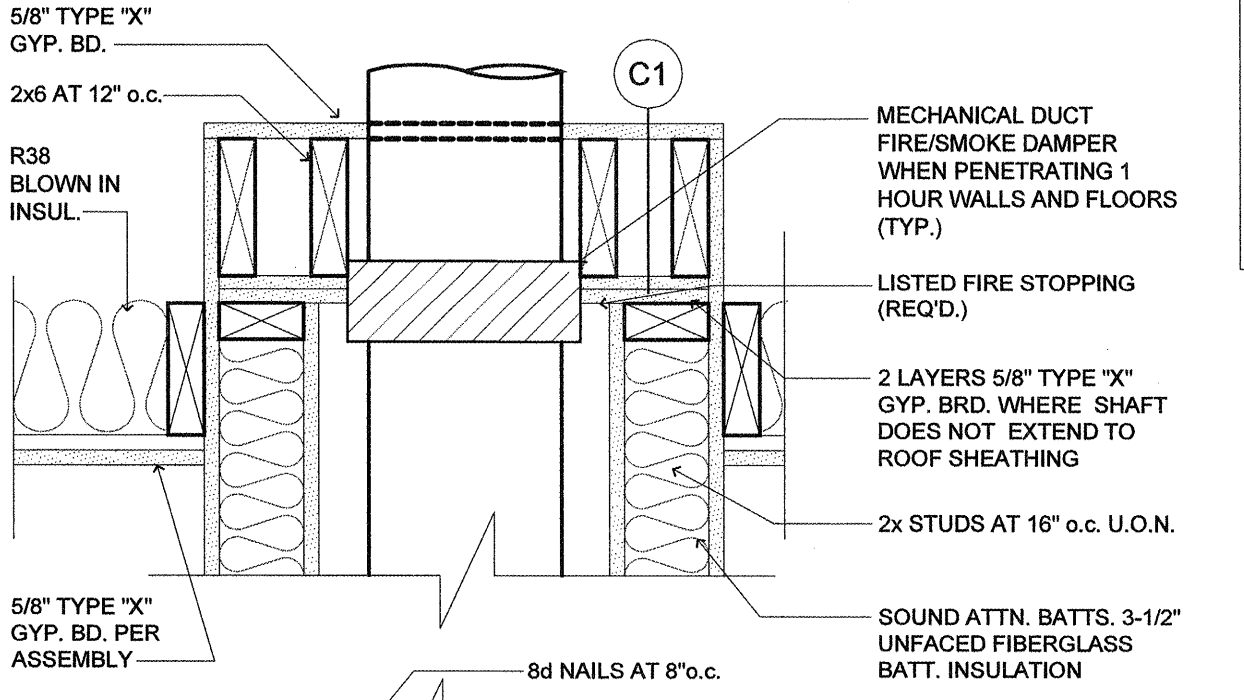

**8** INT. WALL ASSEMBLY  
(1 HR MECHANICAL CHASE)  
SCALE: 1-1/2" = 1'-0"

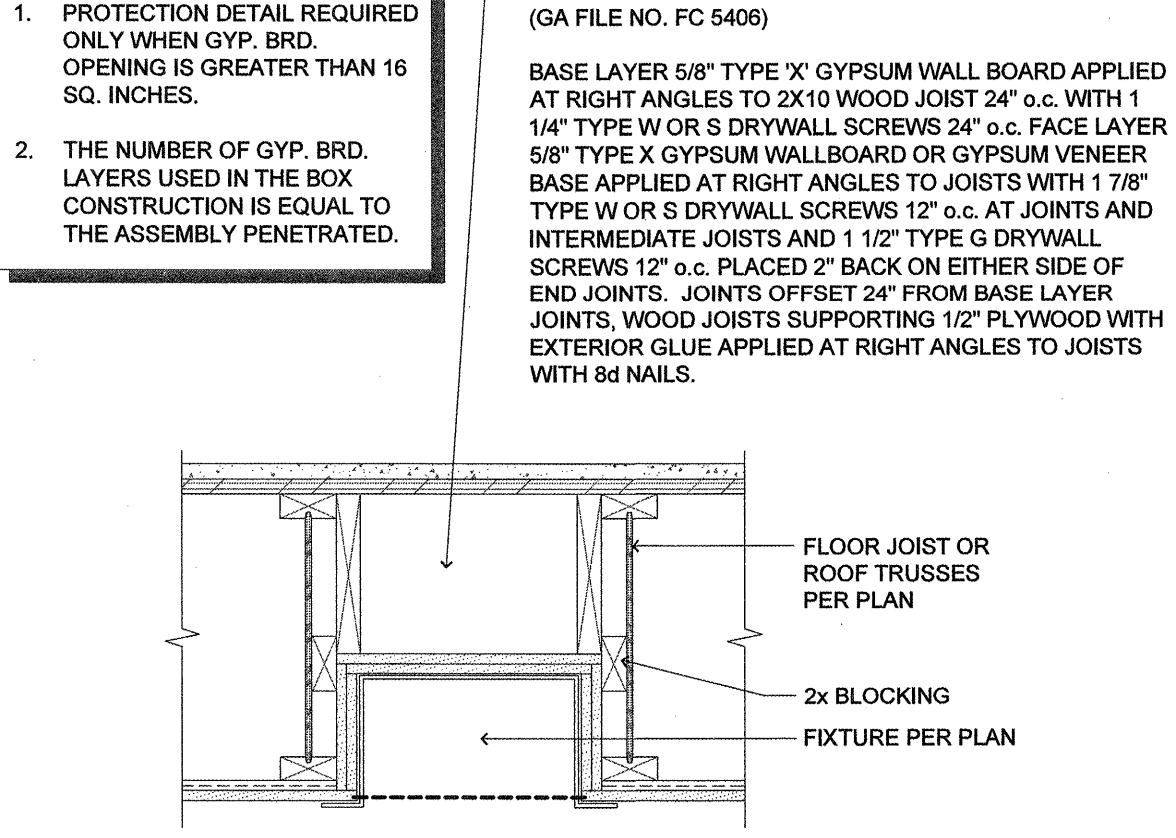

**7** FIXTURE PROTECTION  
HEAT LAMP, LIGHT FIXTURE/SPEAKER  
SCALE: N.T.S.

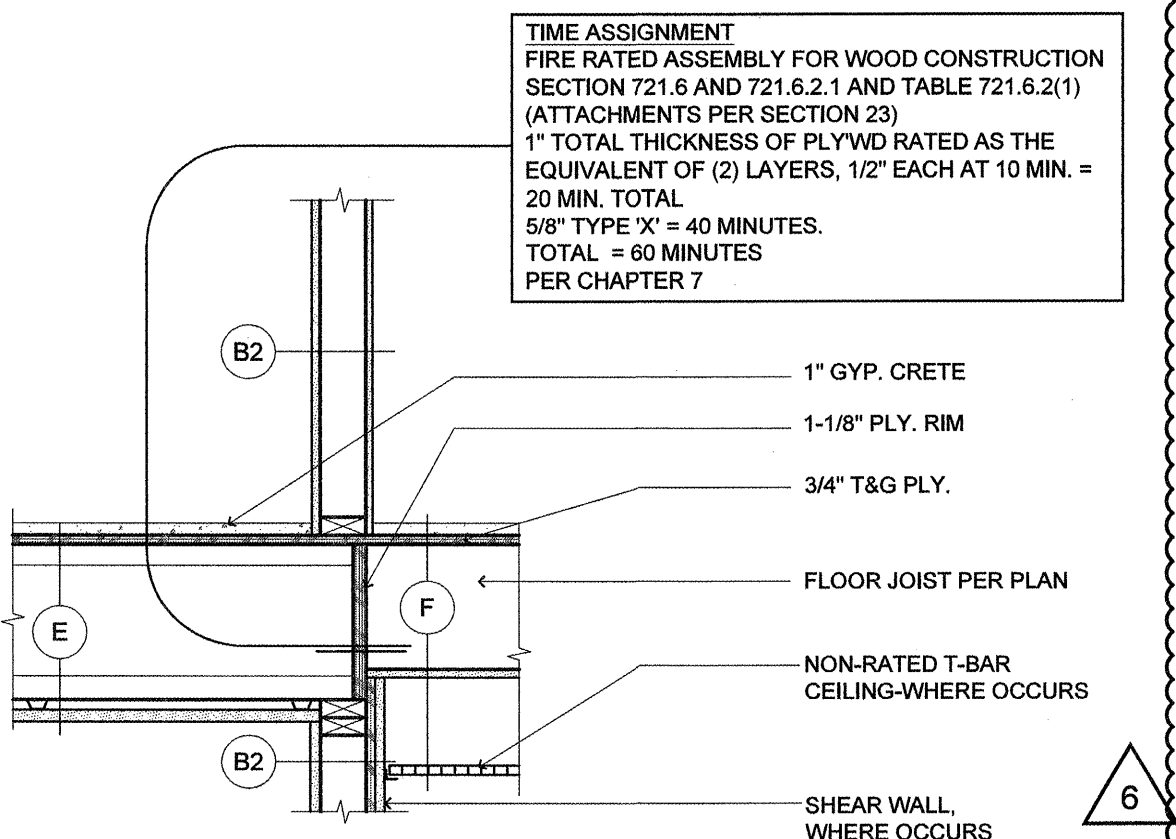

**6** SECTION AT CORRIDOR  
(ALL TRADES TO COORDINATE AVAILABLE SPACE)  
SCALE: 1-1/2" = 1'-0"

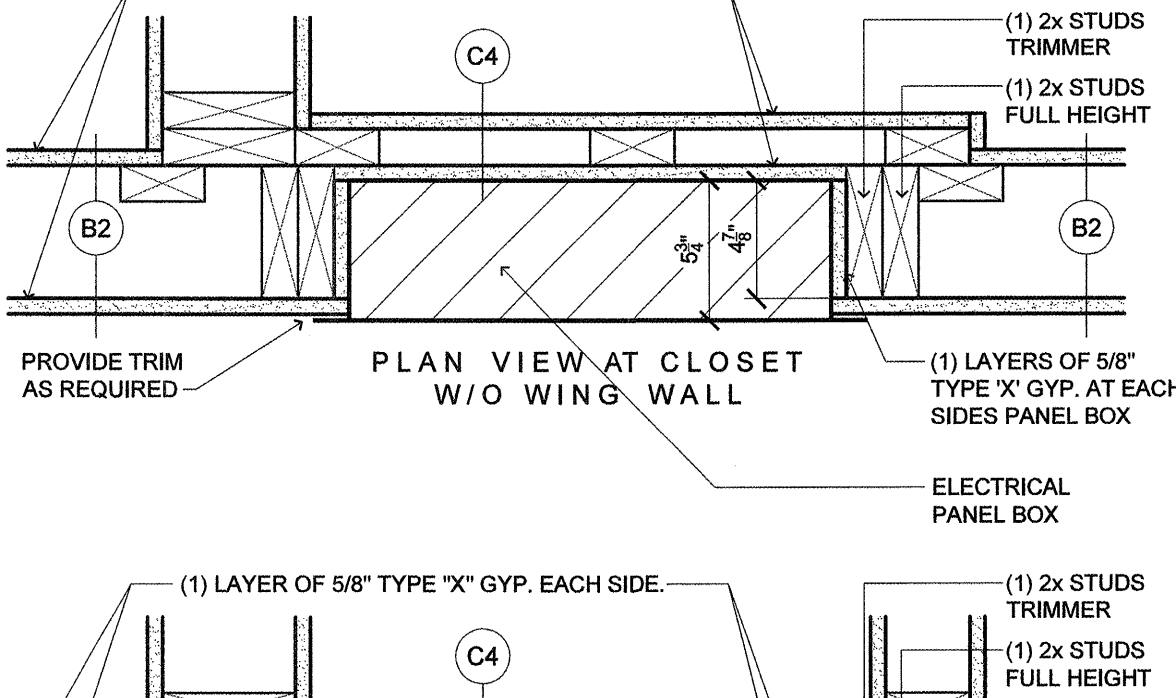
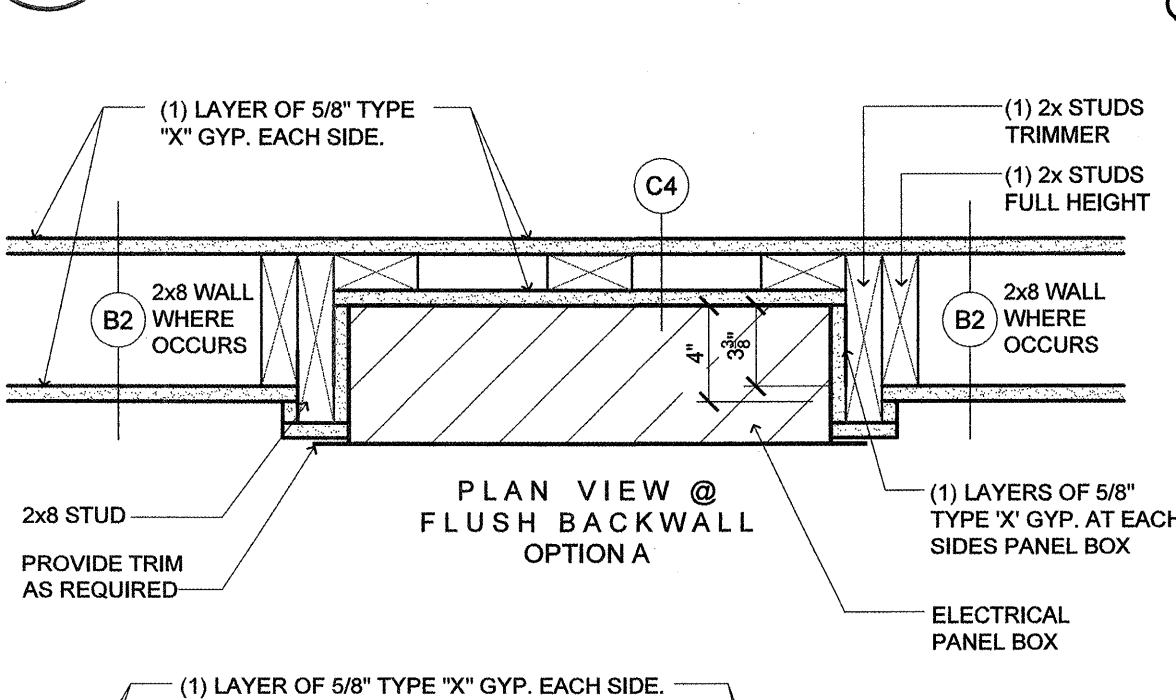

**5** ELEC. PANEL  
(FIRE RATED)  
SCALE: N.T.S.

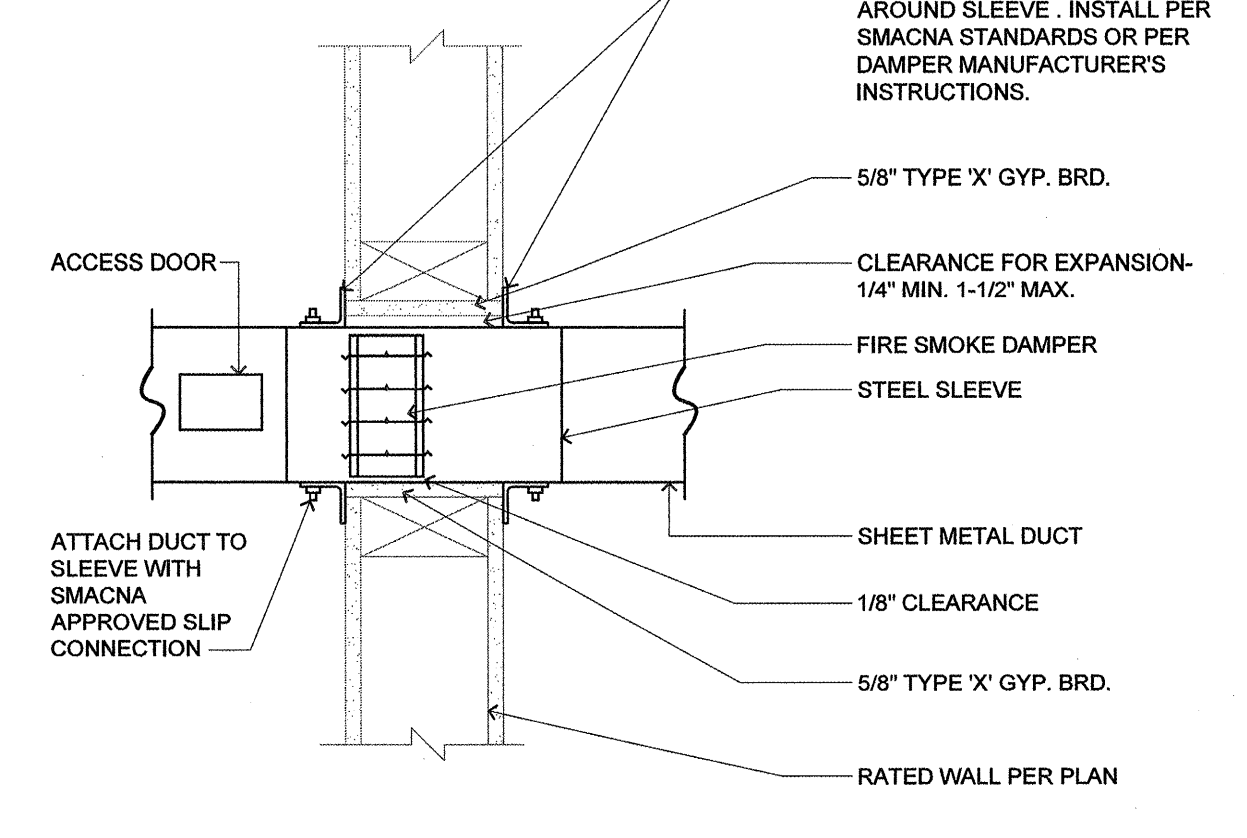

**4** FIRE/SMOKE DAMPER IN WALL  
SCALE: N.T.S.

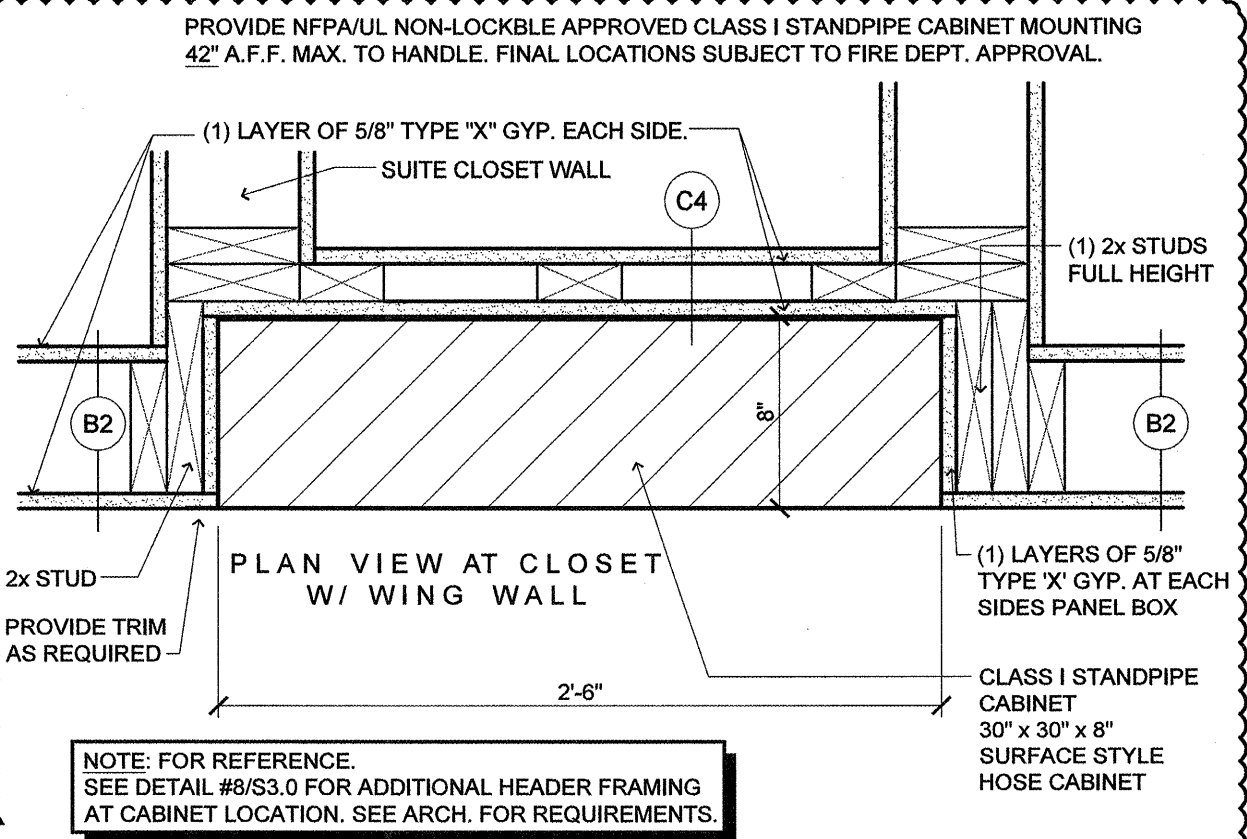

**3** STANDPIPE CABINET  
(FIRE RATED)  
SCALE: N.T.S.

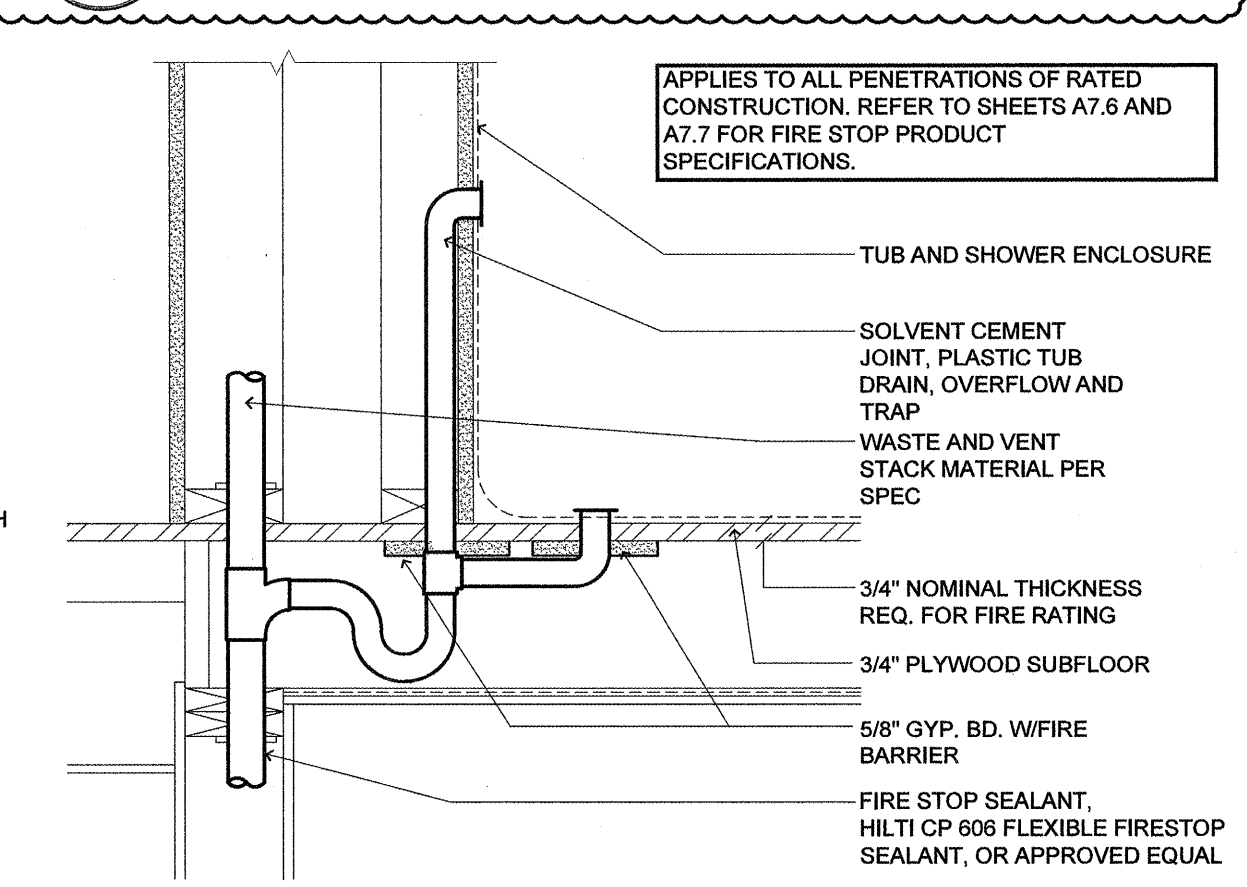

**2** TUB AND SHOWER DRAIN DETAIL  
SCALE: N.T.S.

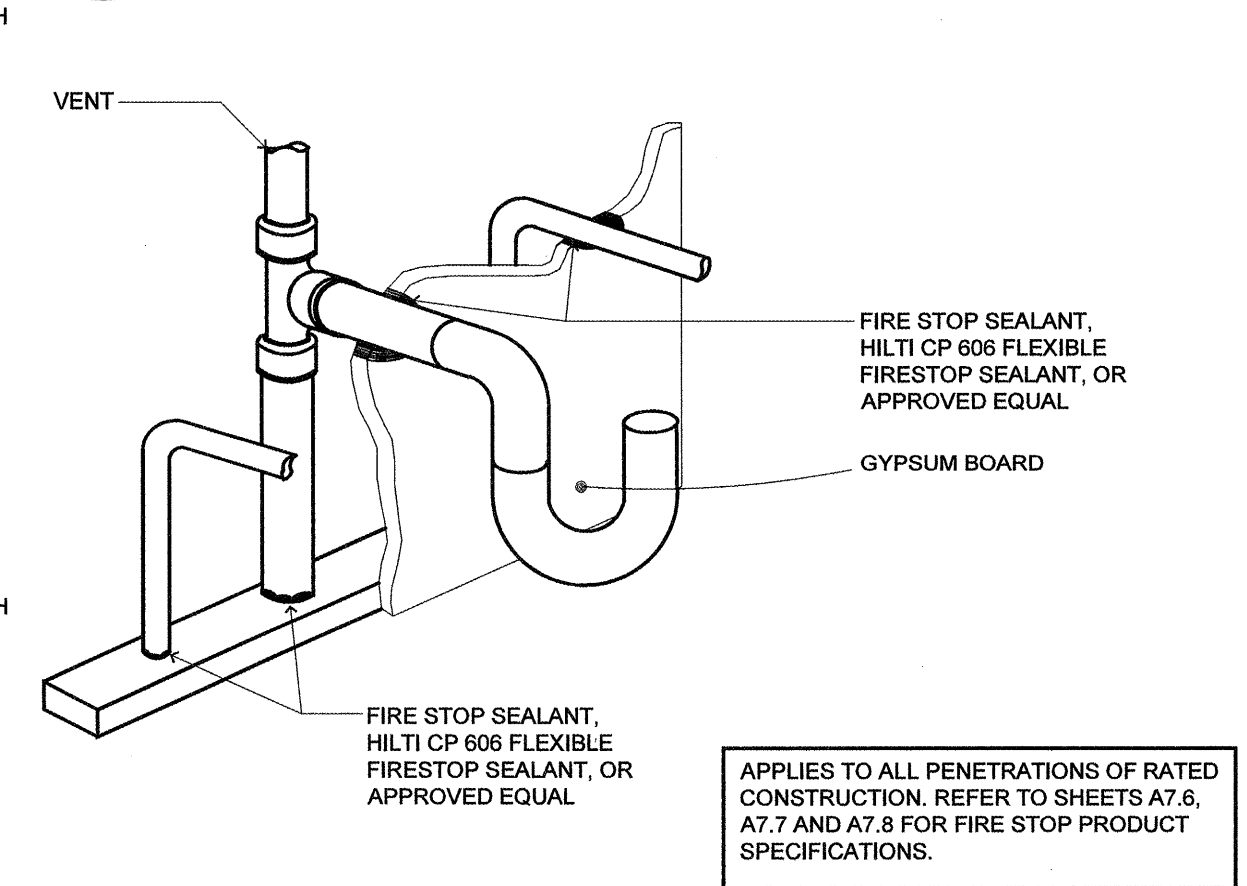

**1** PLUMBING DETAIL  
(AT FIRE RATED CONSTRUCTION)  
SCALE: N.T.S.

DATE: 8/28/2015 8:44 AM; USERNAME: dhr422017; 10:00 AM; HEADLINE: lenity-architect.com; PROJECT: PORTLAND RETIREMENT RESIDENCE; FILE: A8.8; CONTACT: daniel@lenity.com