

NOTE: WRAP ENTIRE EXTERIOR OF BUILDING WITH BLDG PAPER. ALL JOINTS TO BE TAPED WITH SHEATHING TAPE. SYSTEM MUST BE INSTALLED IN ACCORDANCE WITH MANUF. INSTALLATION INSTRUCTIONS TO PROVIDE 10 YR. WARRANTY TO GENERAL CONTRACTOR

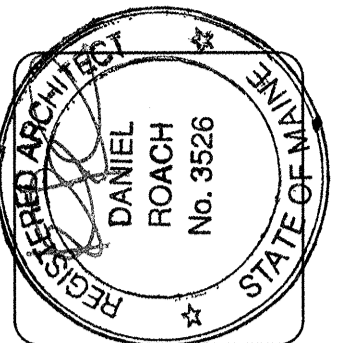

lenity
architecture
3155 New Market Street, Suite 200
Portland, ME 04103
Phone: (503) 599-0545
www.lenityarch.com

COLSON AND COLSON
GENERAL CONTRACTOR, INC.
2280 McGilchrist Street, Suite 200
Salem, Oregon 97302
Phone: (503) 586-7401

PORTLAND
RETIREMENT RESIDENCE
802 OCEAN AVE. PORTLAND, MAINE 04103

CEMENT SIDING
EXT. BUILDINGS
DETAILS

DATE: 8/28/2015
REVISED DATE: 9/22/2015
2/2/2016
7/18/2016

SHEET
A6.5

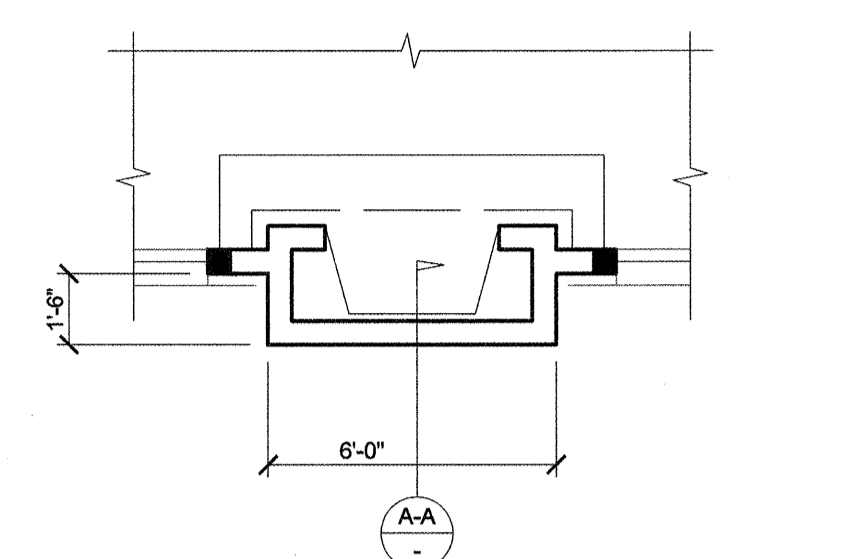

3 FIRE PLACE A-A (AT EXTERIOR WALL)
SCALE: 1/2" = 1'-0"

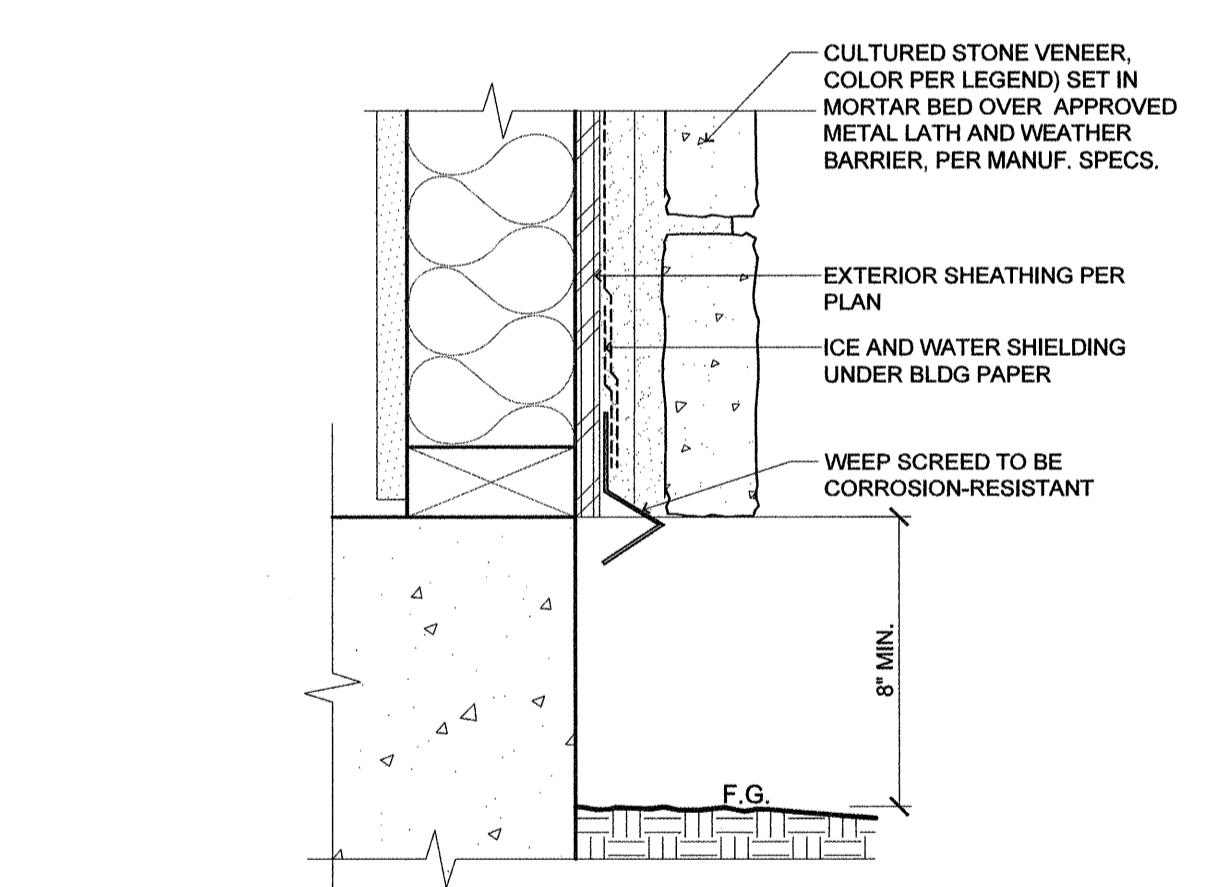

2 EXTERIOR WALL DETAIL (WEEP SCREED)
SCALE: 3" = 1'-0"

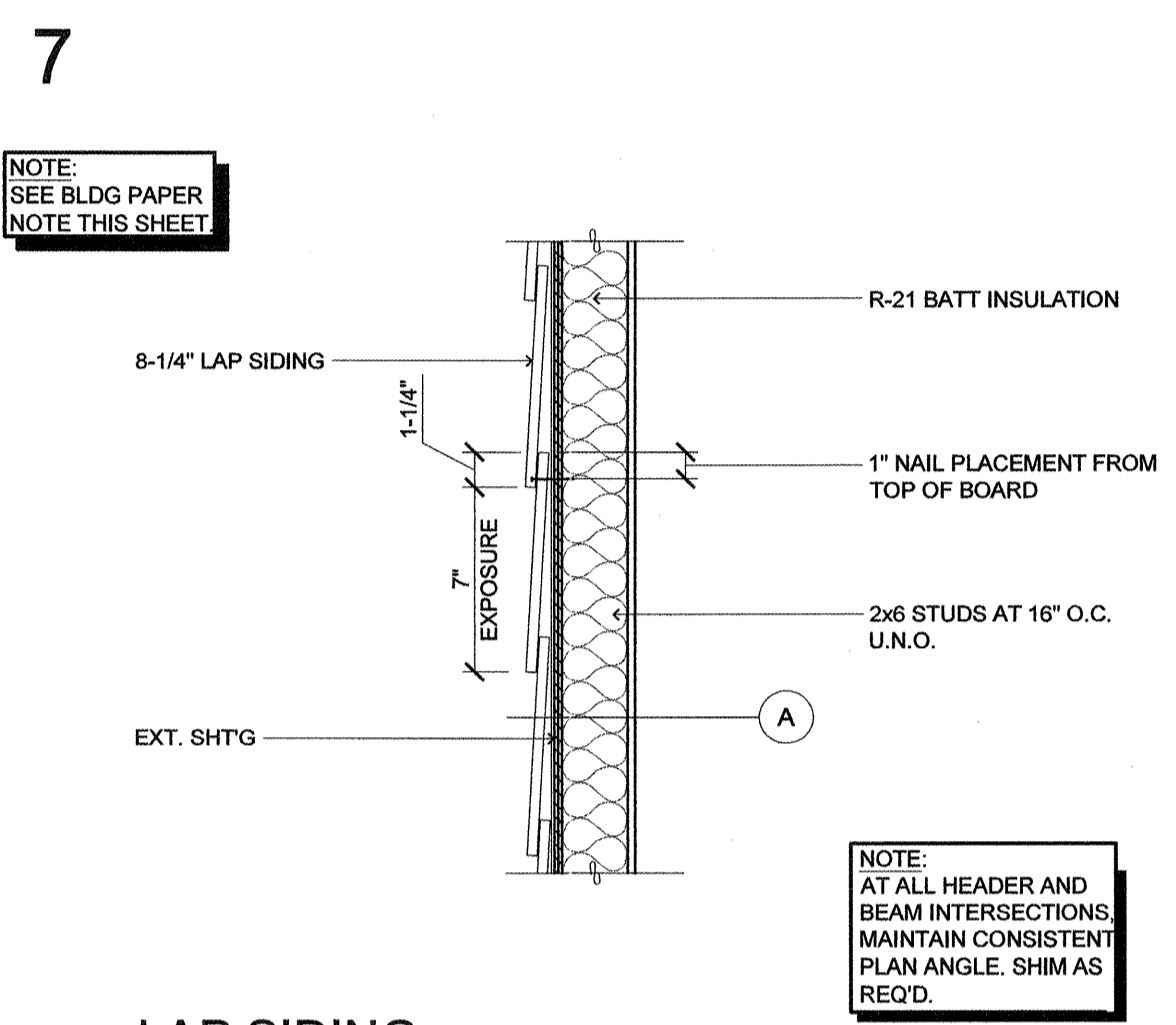

4 EXTERIOR WALL DETAIL (STONE / CEM. BRD. SIDING)
SCALE: 1-1/2" = 1'-0"

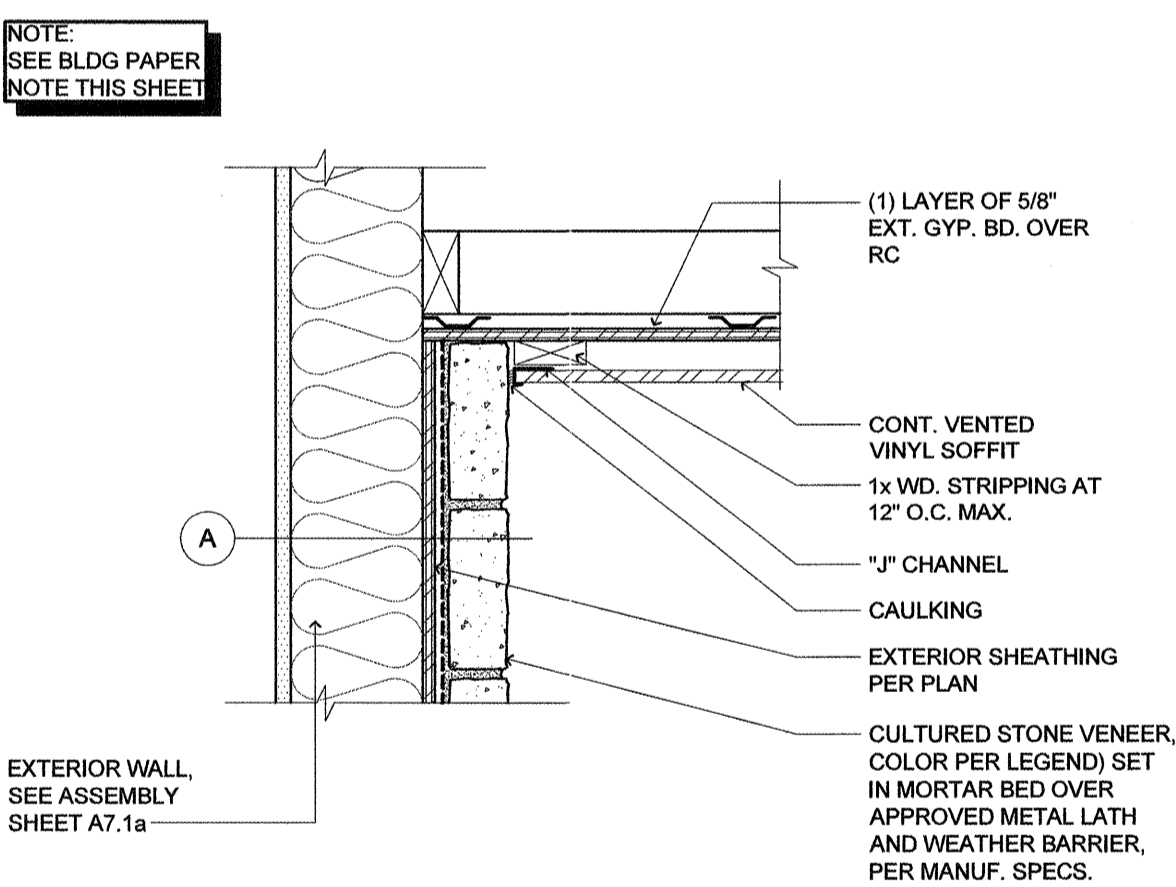

5 EXTERIOR WALL DETAIL (EXT. STONE OVER WOOD FRAMING)
SCALE: 1-1/2" = 1'-0"

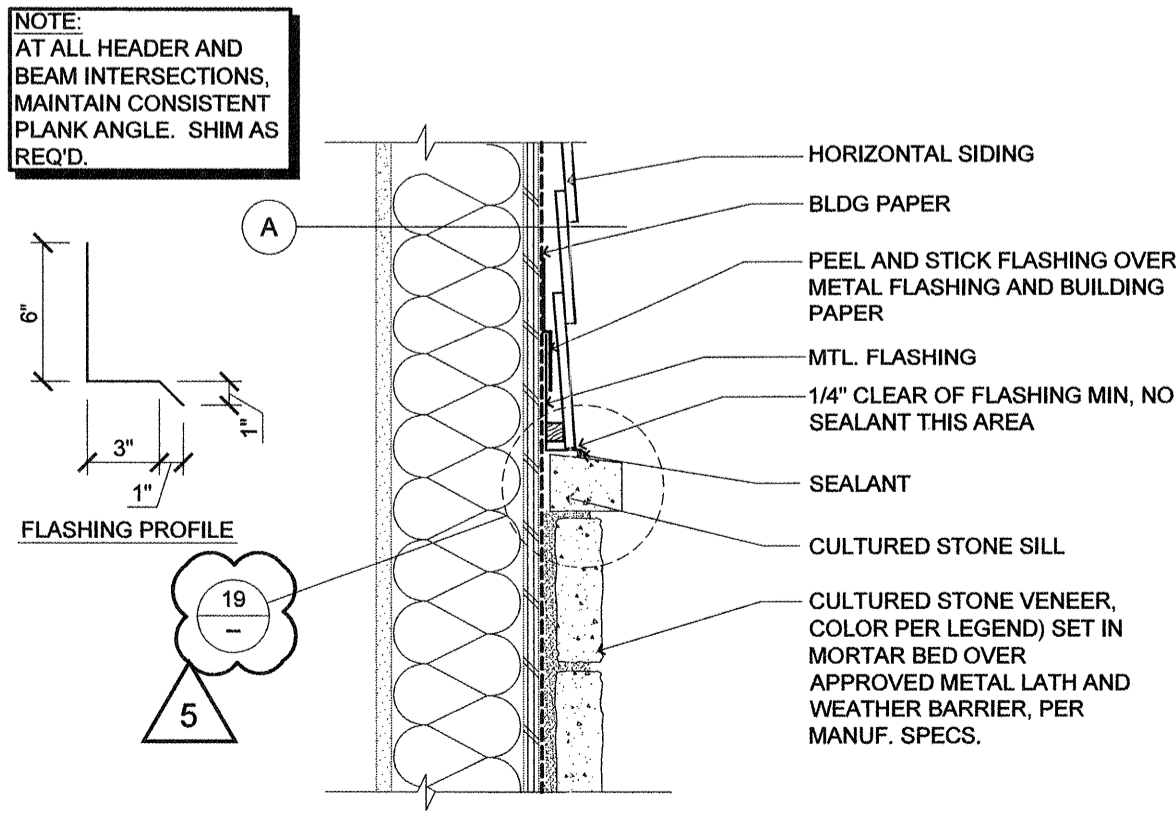

6 LAP SIDING (SPACING DETAIL)
SCALE: 1-1/2" = 1'-0"

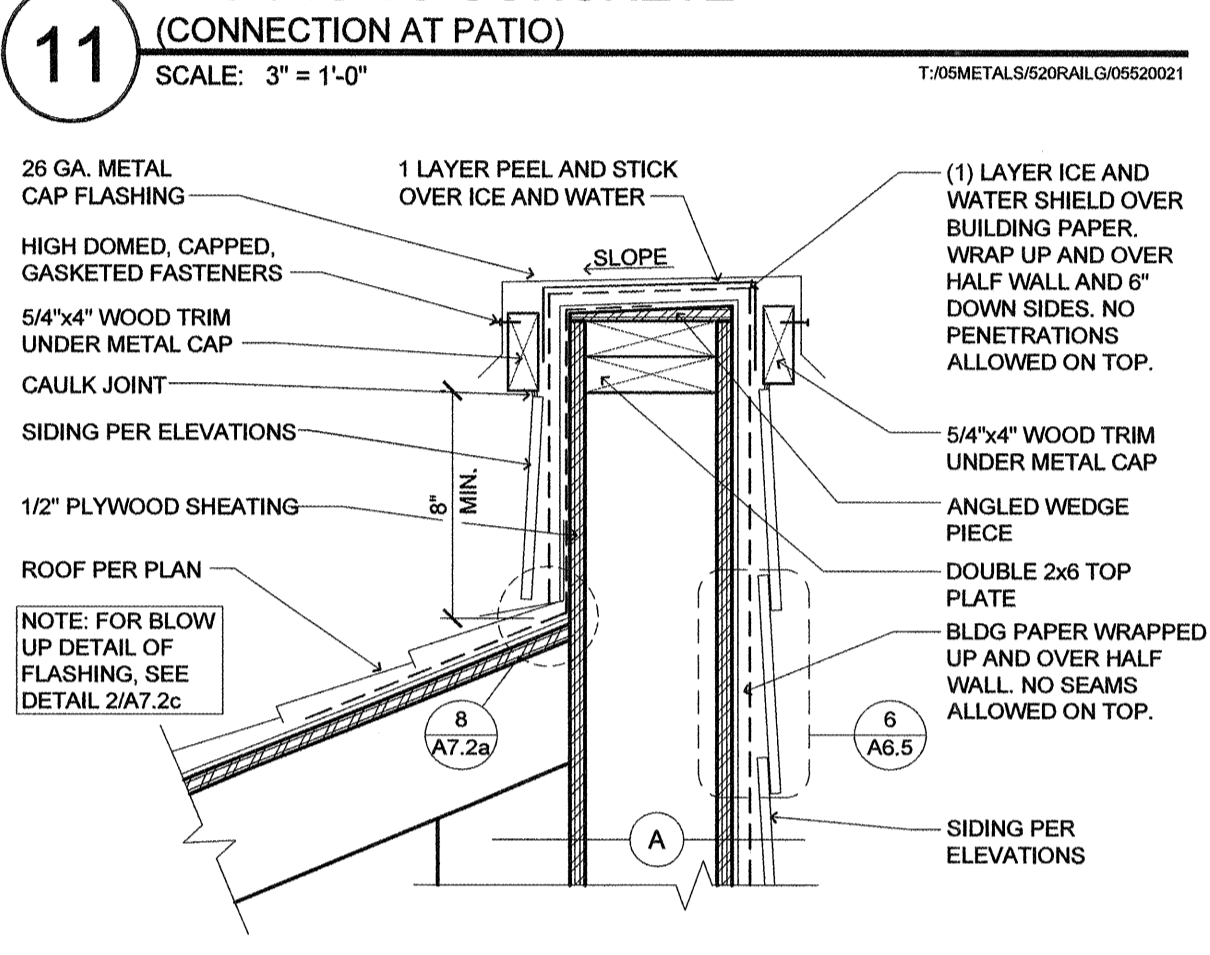

7 RAILING TO CONCRETE (CONNECTION AT PATIO)
SCALE: 3" = 1'-0"

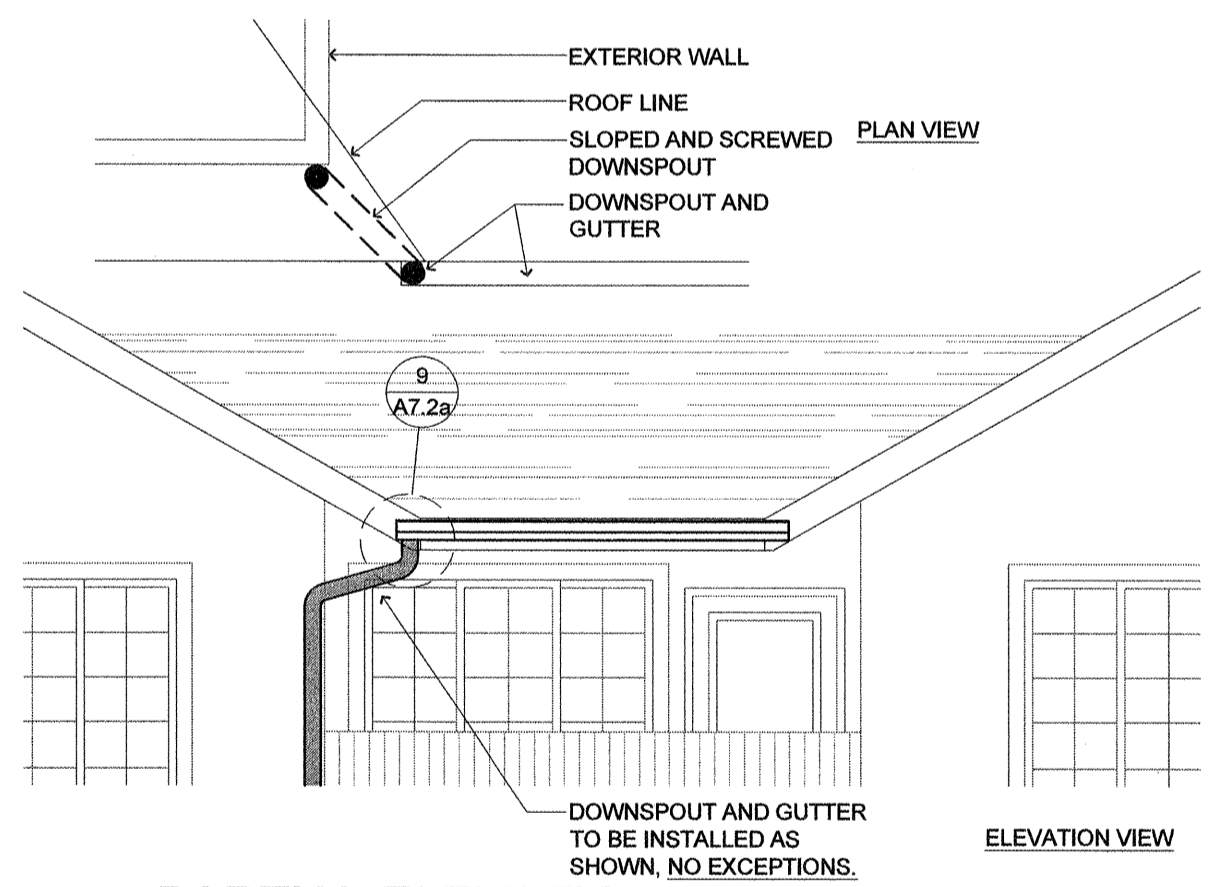

8 ROOF/WALL INTERSECTION (AT HALF WALL)
SCALE: 1-1/2" = 1'-0"

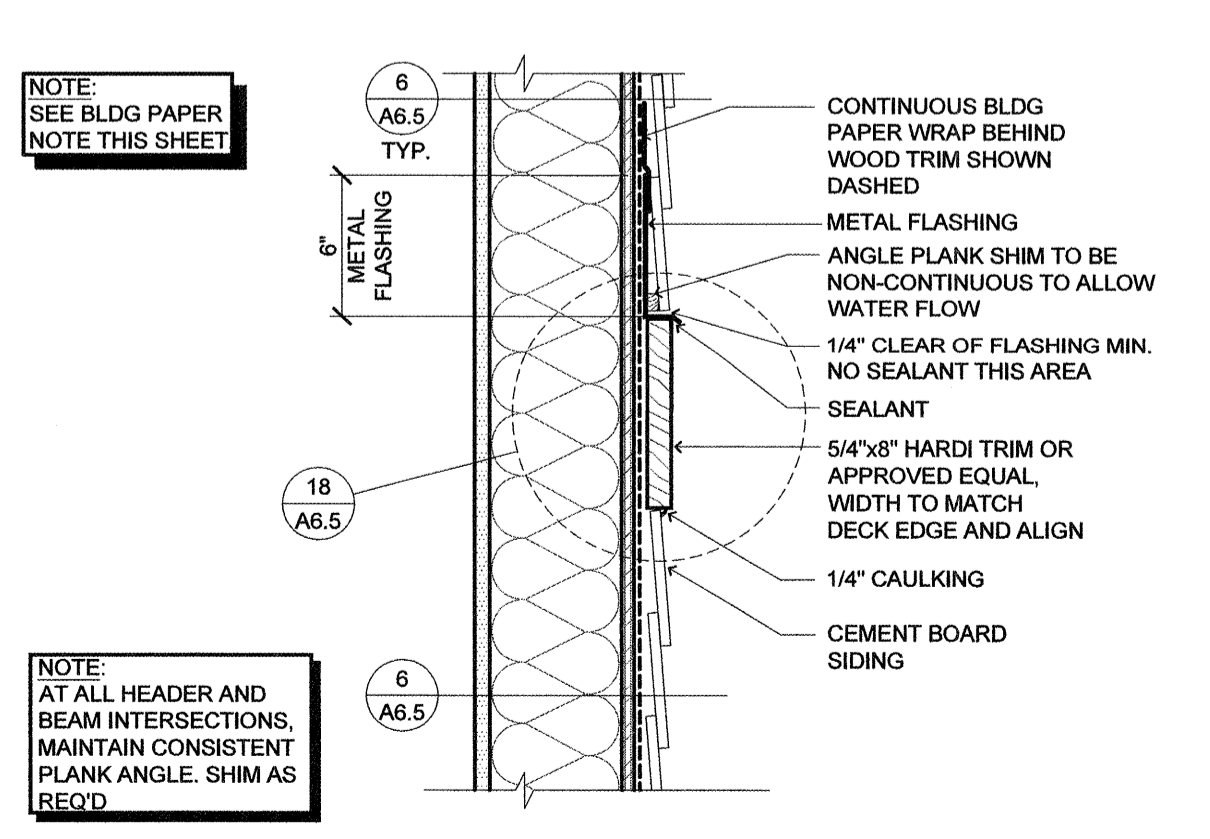

9 PARTIAL ELEVATION (GUTTER AND DOWNSPOUT LOCATION)
SCALE: 1/4" = 1'-0"

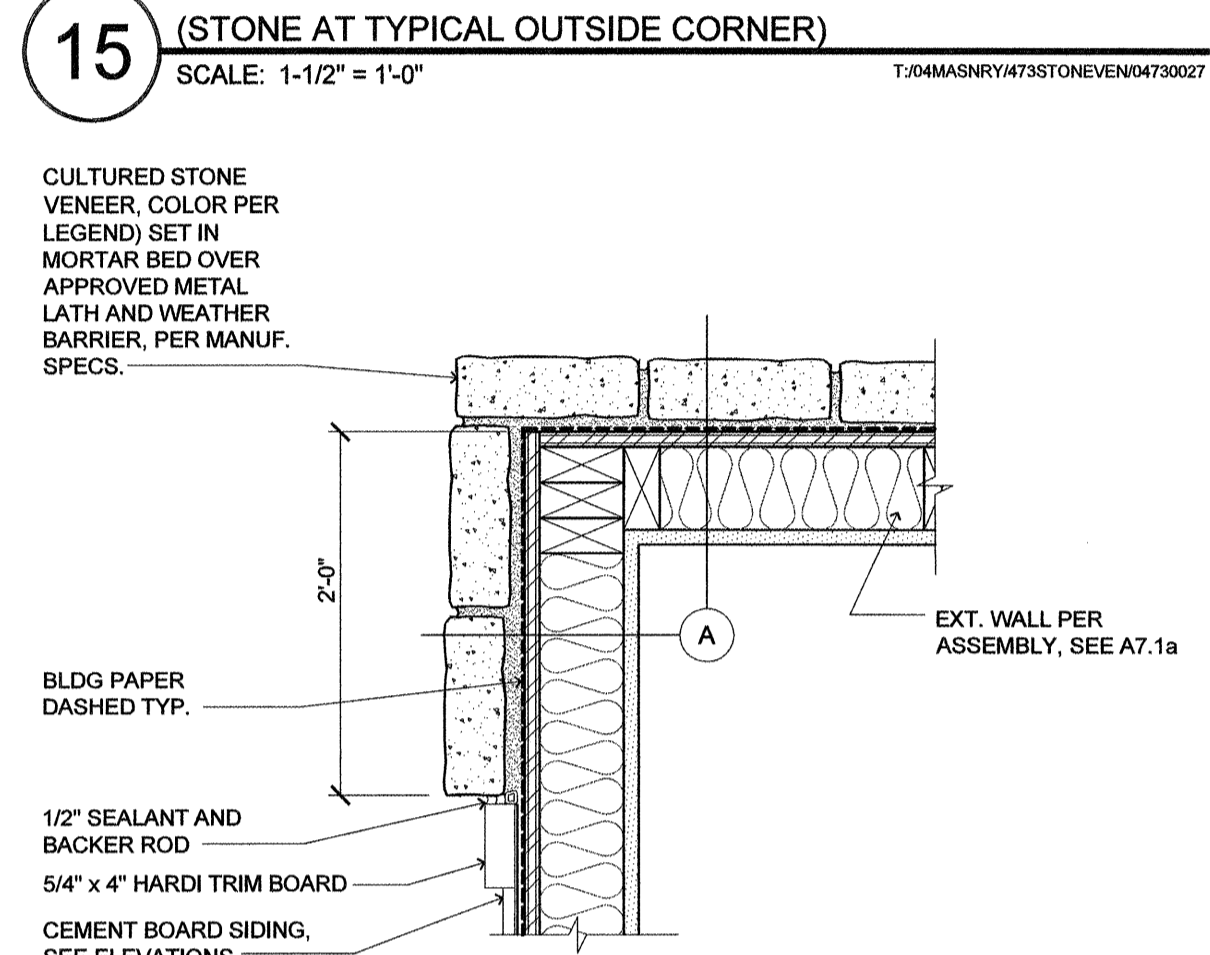

10 STONE CORNER (STONE AT TYPICAL OUTSIDE CORNER)
SCALE: 1-1/2" = 1'-0"

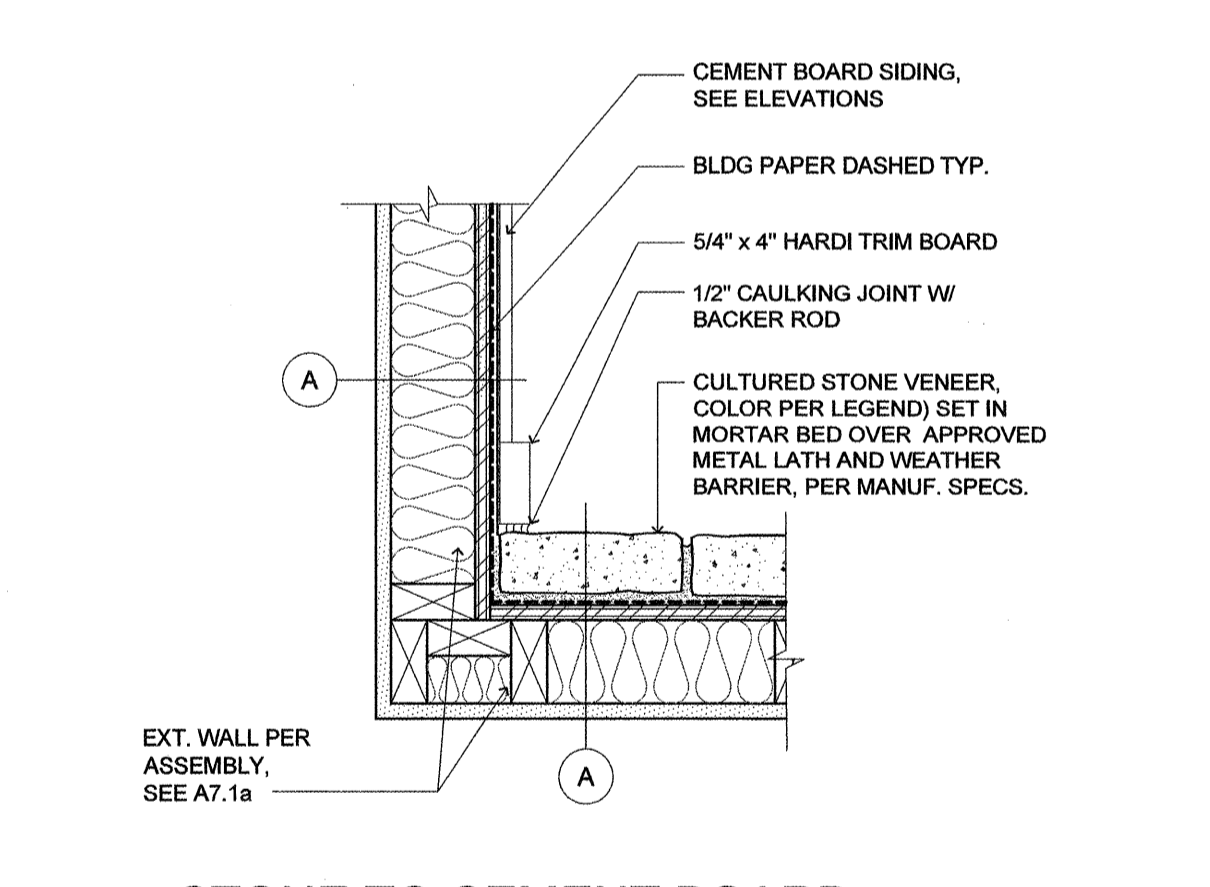

11 STONE VENEER (STONE AT TYPICAL OUTSIDE CORNER)
SCALE: 1-1/2" = 1'-0"

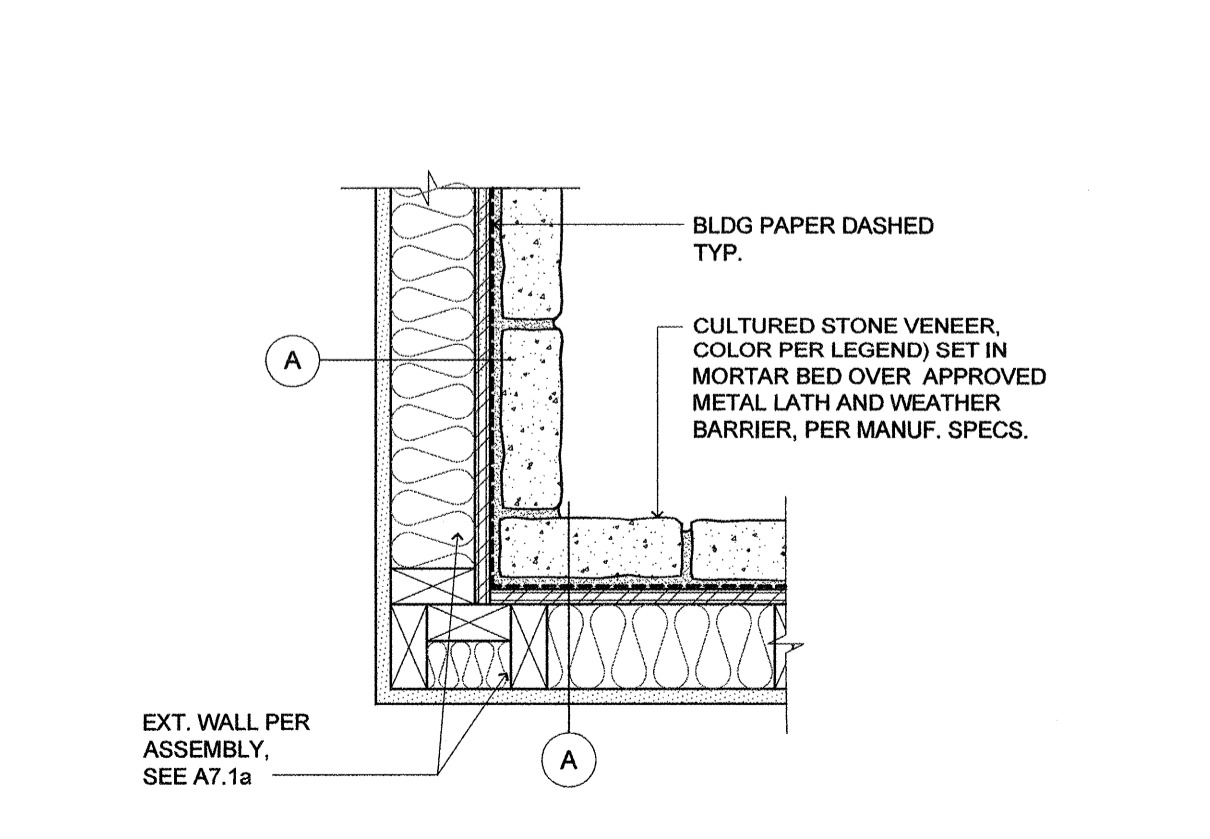

12 STONE TO CEMENT BOARD (STONE VENEER)
SCALE: 1-1/2" = 1'-0"

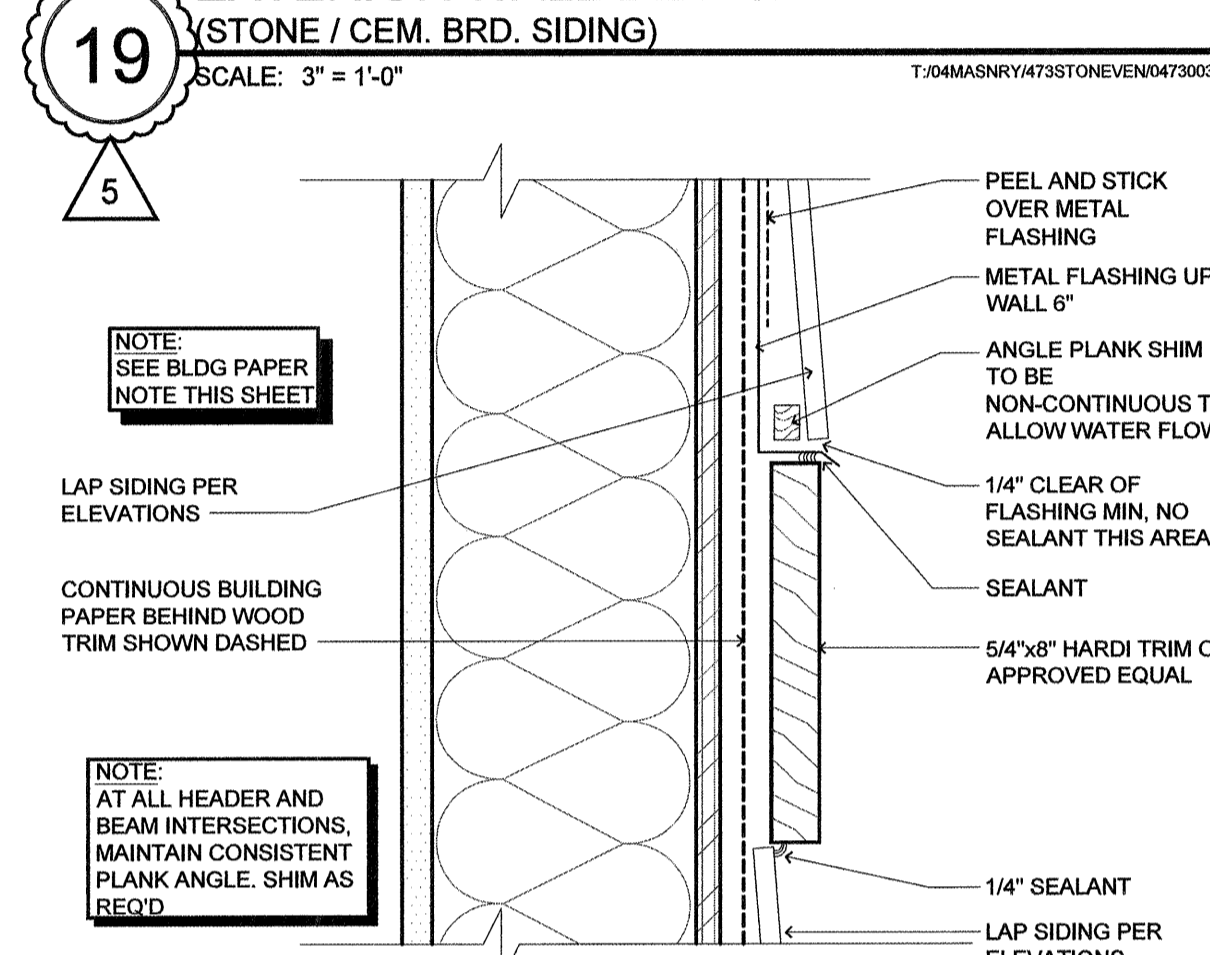

13 EXTERIOR WALL DETAIL (STONE / CEM. BRD. SIDING)
SCALE: 3" = 1'-0"

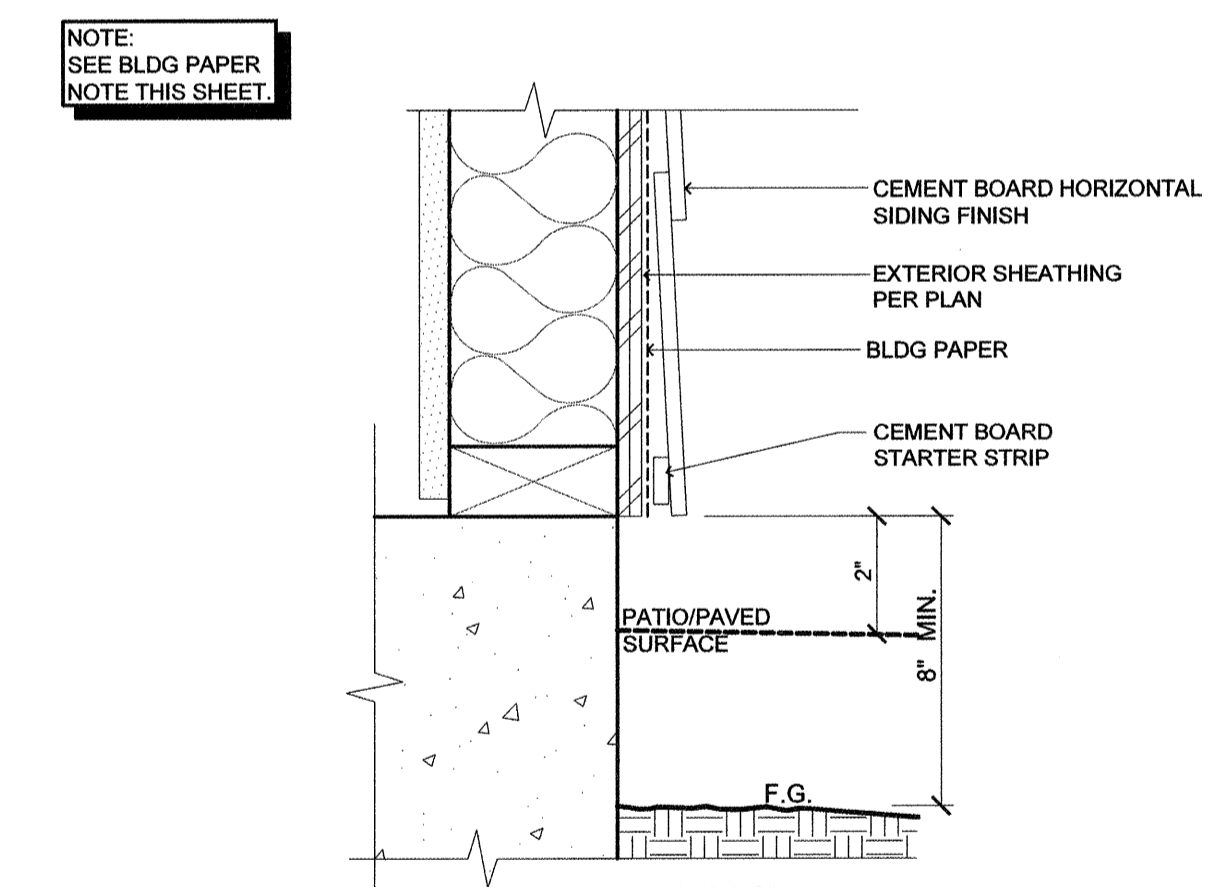

14 BELLY BAND DETAIL (CEM. BRD. SIDING)
SCALE: 3" = 1'-0"

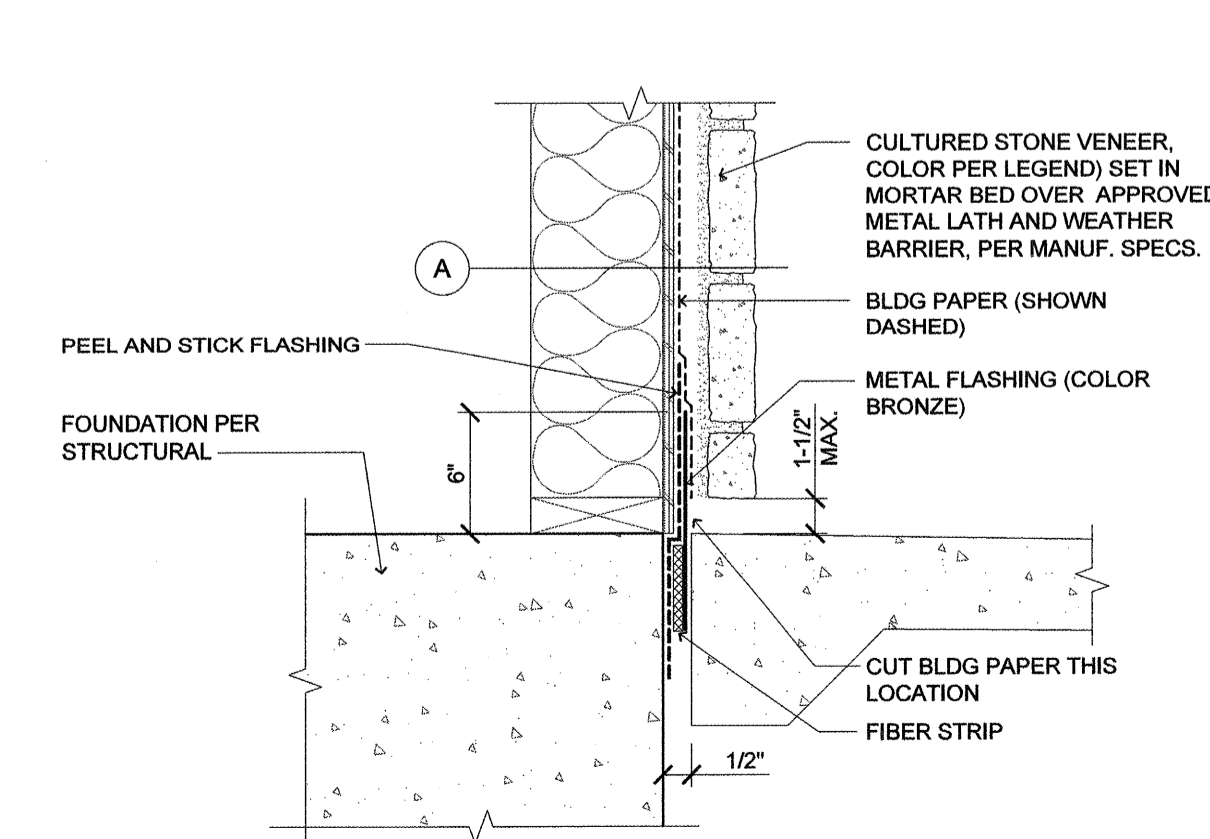

15 WALL AT BASE (AT PATIO)
SCALE: N.T.S.

NOT USED

8/28/2015 10:33 AM Initial: pds/3/20/15 2:04 PM Job: pds/ 8/28/2015/lenity-architectural/5-cement-siding-ext-buildings-ext-bldg-a6.5