

CONSTRUCTION ASSEMBLY	
GA-600-2012 FIRE RESISTANCE DESIGN MANUAL (GA FILE NO. RC 2750)	
NOTES	DESCRIPTION
1	2x10 WOOD JOISTS 24" O.C.
2	3/4" T & G EDGE PLYWOOD APPLIED AT RIGHT ANGLES TO JOISTS WITH 8d NAILS AT 6" O.C. AT JOINTS AND 12" AT INTERMEDIATE JOINTS.
3	BASE LAYER - 5/8" TYPE X GYPSUM WALL BOARD APPLIED AT RIGHT ANGLES TO 2x10 WOOD JOISTS 24" O.C. WITH 1-1/4" TYPE W OR S DRYWALL SCREWS 12" O.C.
4	SECOND LAYER - 5/8" TYPE X GYPSUM WALLBOARD APPLIED AT RIGHT ANGLES TO JOISTS WITH 2" TYPE W DRYWALL SCREWS 12" O.C. JOINTS OFFSET 24" FROM BASE LAYER JOINTS.
5	THIRD LAYER - 5/8" TYPE X GYPSUM WALLBOARD APPLIED AT RIGHT ANGLES TO JOISTS WITH 2-1/2" TYPE W DRYWALL SCREWS 12" O.C. JOINTS OFFSET 12" FROM SECOND LAYER JOINTS
6	HAT SHAPED FURRING CHANNELS 24" O.C. APPLIED AT RIGHT ANGLES TO JOISTS OVER THIRD LAYER WITH TWO 2-1/2" LONG TYPE W DRYWALL SCREWS AT EACH JOIST
7	FACE LAYER - 5/8" TYPE X GYPSUM WALLBOARD APPLIED AT RIGHT ANGLES TO FURRING CHANNELS WITH 1-1/8" TYPE S DRYWALL SCREWS 12" O.C.
ACTUAL FIRE RESISTANCE RATING 2 HOUR FIRE	
SOUND RATING N/A	

### ROOF-CEILING ASSEMBLY

(2 HR RAFTERS)  
SCALE: 1-1/2"=1'-0"

(RC 2750)  
T:\09\FINSH\2500\Y9PBD\09250199

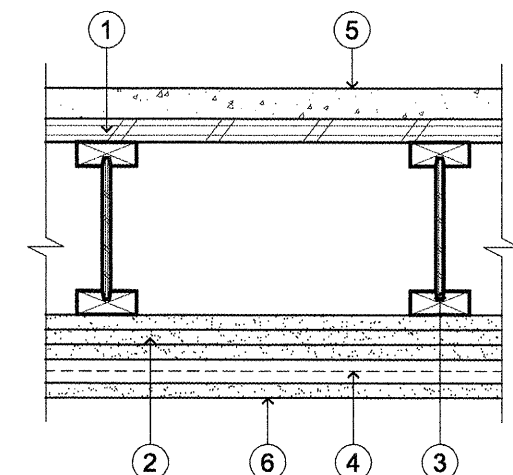

CONSTRUCTION ASSEMBLY	
UL - DESIGN NUMBER L556	
NOTES	DESCRIPTION
1	FINISHED FLOORING: THE FLOORING MUST CONSIST OF A SINGLE LAYER OF 48/24 SPAN-RATED, TONGUE-AND-GROOVE, WOODBASED, STRUCTURAL-USE (EXPOSURE 1), THE FLOORING MUST BE ATTACHED TO THE RED-JOIST TOP FLANGE WITH AFG-01 CONSTRUCTION ADHESIVE, AND NAILED USING 80 COMMON NAILS SPACED A MAXIMUM OF 6 INCHES (152 MM) ON CENTER ALONG THE BOUNDARY AND EDGES AND 12 INCHES (305 MM) ON CENTER IN THE FIELD. WHEN USED AS A ROOF-CEILING ASSEMBLY, A SINGLE LAYER OF SQUARE-EDGE, SPAN-RATED WOOD-BASED, STRUCTURAL-USE (EXPOSURE 1), COMPLYING WITH THE CODE, IS PERMITTED TO BE USED FOR ROOF SHEATHING. ALL BUTT JOINTS OF THE SHEATHING MUST BE LOCATED OVER FRAMING MEMBERS.
2	CEILING: THE CEILING MEMBRANE MUST CONSIST OF THREE LAYERS OF 5/8-INCH-THICK (15.9 MM EACH) TYPE X GYPSUM BOARD. BASE LAYER TO BE APPLIED AT RIGHT ANGLE WITH 2x8 WOOD JOIST WITH 1-1/4" LONG TYPE W DRYWALL SCREWS AT 12" O.C. SECOND LAYER TO BE APPLIED WITH 2" LONG TYPE W DRYWALL SCREWS AT 12" O.C. THIRD LAYER TO BE APPLIED WITH 2-1/2" LONG TYPE W DRYWALL SCREWS AT 12" O.C. FACE LAYER TO BE APPLIED AT RIGHT ANGLE TO FURRING CHANNELS WITH 1-1/8" TYPE S DRYWALL SCREWS AT 12" O.C.
3	STRUCTURAL MEMBERS: WOOD I-JOISTS AT 24" O.C.
4	RESILIENT CHANNELS: 25 GA HAT SHAPED RESILIENT CHANNELS AT 24" O.C. APPLIED AT RIGHT ANGLES TO JOISTS OVER THIRD LAYER OF 5/8" TYPE X GYPSUM BOARD WITH TWO 2-1/2" LONG TYPE W DRYWALL SCREWS AT EACH JOIST.
ACTUAL FIRE RESISTANCE RATING 2 HOUR FIRE	
FINISHES	
5	1" OF CEMENT TOPPING
6	5/8" TYPE X GYPSUM BOARD

### FLOOR CEILING ASSEMBLY

(2 HR RATED CEILING ASSEMBLY)  
SCALE: 1-1/2"=1'-0"

(L556)  
T:\09\FINSH\2500\Y9PBD\09250212

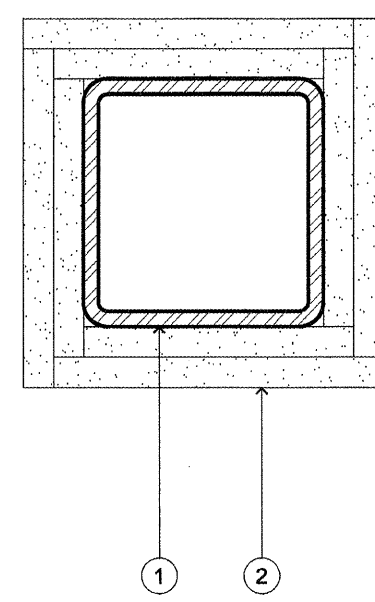

CONSTRUCTION ASSEMBLY	
IBC TABLE 720.1	
NOTES	DESCRIPTION
1	TUBE STEEL COLUMN PER STRUCTURAL
2	#1-7.1 MULTIPLE LAYERS OF 1/2" GYPSUM WALLBOARD ADHESIVELY SECURED TO COLUMN FLANGES AND SUCCESSIVE LAYERS. WALLBOARD APPLIED WITHOUT HORIZONTAL JOINTS. CORNER EDGES OF EACH LAYER STAGGERED. WALLBOARD LAYER BELOW OUTER LAYER SECURED TO COLUMN WITH DOUBLED 0.049 INCH (NO. 18 B.W. GAGE) STEEL WIRE TIES SPACED 15" ON CENTER. EXPOSED CORNERS TAPED AND TREATED.
ACTUAL FIRE RESISTANCE RATING 1 HOUR FIRE	
SOUND RATING N/A	

### T.S. COLUMN

(1 HR)  
SCALE: 1-1/2"=1'-0"

2009 IBC  
TABLE: 720.1  
#1-7.1  
T:\09\FINSH\2500\Y9PBD\09250194

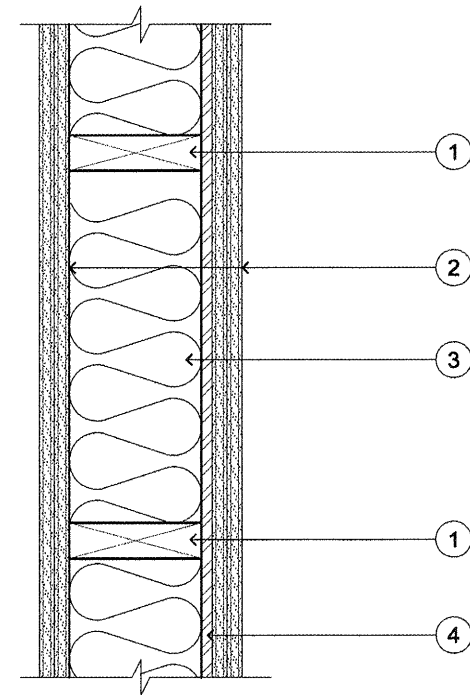

CONSTRUCTION ASSEMBLY	
GA-600-2012 FIRE RESISTANCE DESIGN MANUAL (GA FILE NO. WP 4136)	
NOTES	DESCRIPTION
1	2x6 STUDS AT 16" O.C. U.O.N.
2	BASE LAYER: 5/8" TYPE X GYPSUM WALLBOARD OR VENEER BASE APPLIED PARALLEL OR AT RIGHT ANGLES TO EACH SIDE OF 2x6 WOOD STUDS AT 16" O.C. WITH 1-1/4" TYPE W DRYWALL SCREWS 12" O.C. FACE LAYER: 5/8" TYPE X GYPSUM WALLBOARD OR VENEER BASE APPLIED PARALLEL OR AT RIGHT ANGLES TO EACH SIDE WITH 1-7/8" TYPE W DRYWALL SCREWS 12" O.C. AND OFFSET 6" FROM SCREWS IN BASE LAYER.
3	JOINTS STAGGERED 16" EACH LAYER AND SIDE. (LOAD-BEARING)
4	3-1/2" SOUND BATT INSULATION WHERE INDICATED ON FLOOR PLANS
5	SHEAR PANEL (AS OCCURS) SEE STRUC. SHEAR WALL PLAN.
ACTUAL FIRE RESISTANCE RATING 2 HOUR FIRE	
SOUND RATING 40 TO 44 STC	

### STAIR/SHAFT WALL

(2 HOUR WALL)  
SCALE: 1-1/2"=1'-0"

(WP 4136)  
T:\09\FINSH\2500\Y9PBD\09250641

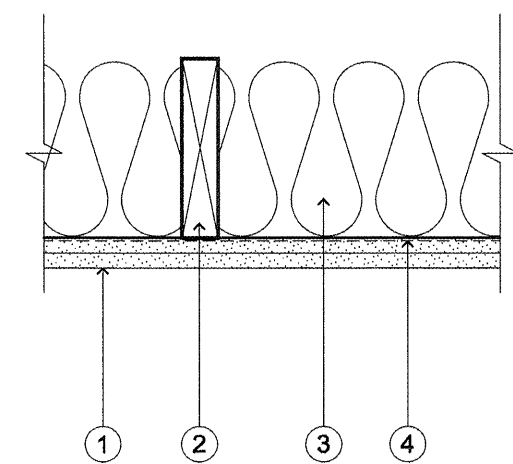

CONSTRUCTION ASSEMBLY	
GA-600-2012 FIRE RESISTANCE DESIGN MANUAL (GA FILE NO. RC 2601)	
NOTES	DESCRIPTION
1	BASE LAYER - 5/8" TYPE X GYPSUM WALL BOARD APPLIED AT RIGHT ANGLES TO 2x10 WOOD JOISTS 24" O.C. WITH 1 1/4" TYPE W OR S DRYWALL SCREWS 24" O.C.
2	2x10 MINIMUM WOOD JOISTS 24" o.c.
3	R-38 LOOSE FILL OR BATT INSULATION
4	6 MIL. VAPOR BARRIER
ACTUAL FIRE RESISTANCE RATING 1 HOUR FIRE	
SOUND RATING N/A	

### ROOF-CEILING ASSEMBLY

(1 HR RAFTERS)  
SCALE: 1-1/2"=1'-0"

(RC 2601)  
T:\09\FINSH\2500\Y9PBD\09250183

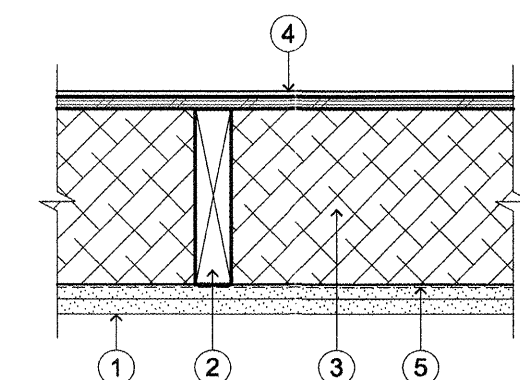

CONSTRUCTION ASSEMBLY	
GA-600-2012 FIRE RESISTANCE DESIGN MANUAL (GA FILE NO. RC 2601)	
NOTES	DESCRIPTION
1	BASE LAYER - 5/8" TYPE X GYPSUM WALL BOARD APPLIED AT RIGHT ANGLES TO 2x10 WOOD JOISTS 24" O.C. WITH 1-1/4" TYPE W OR S DRYWALL SCREWS 24" O.C.
2	2x10 MINIMUM WOOD JOISTS 24" o.c.
3	PROVIDE A MIN. OF R-30 POLYURETHANE FOAM INSULATION
4	BUILT-UP ROOFING OVER APA RATED SHEATHING, TYP. (19/32" SHEATHING IN MECHANICAL WELLS)
5	6 MIL. VAPOR BARRIER
ACTUAL FIRE RESISTANCE RATING 1 HOUR FIRE	
SOUND RATING N/A	

### ROOF-CEILING ASSEMBLY

(1 HR RAFTERS)  
SCALE: 1-1/2"=1'-0"

(RC 2601)  
T:\09\FINSH\2500\Y9PBD\09250180

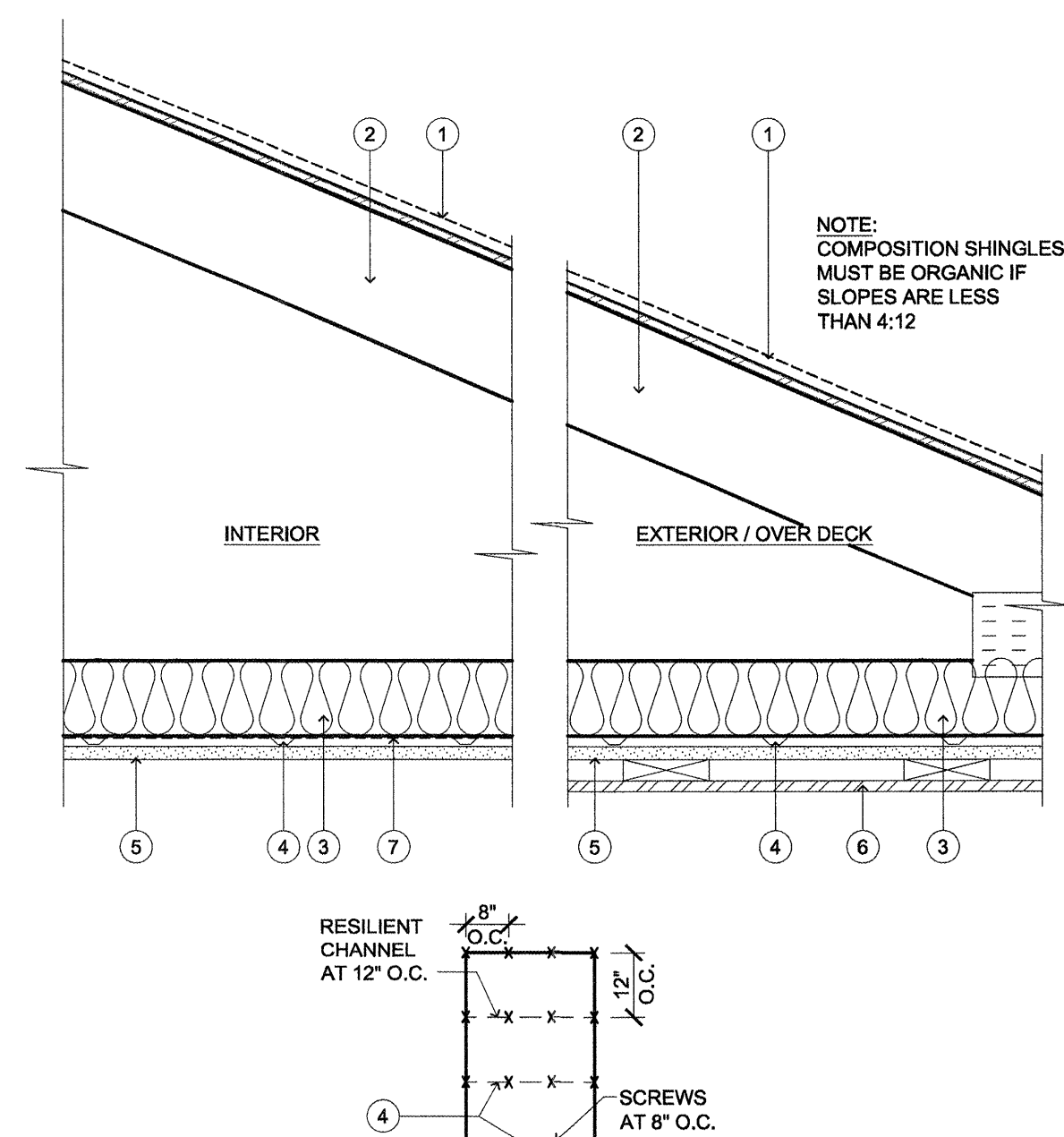

CONSTRUCTION ASSEMBLY	
UL DESIGN NUMBER P533	
NOTES	DESCRIPTION
1	ROOFING SYSTEM OVER 15# FELT SEE EXTERIOR ELEVATIONS. OVER 15/32" STRUCTURAL PANELS SECURED TO TRUSSES WITH NO. 6d RINGED SHANK NAILS SPACED 12" o.c. ALONG EACH TRUSS. STAPLES HAVING EQUAL OR GREATER WITHDRAWAL AND LATERAL RESISTANCE STRENGTH MAY BE SUBSTITUTED FOR THE 6d NAILS. CONSTRUCTION ADHESIVE MAY BE USED WITH EITHER THE NAILS OR STAPLES.
2	TRUSSES - PITCHED OR PARALLEL CHORD WOOD TRUSSES, SPACED A MAX OF 24 IN. OC, FABRICATED FROM NOM 2 BY 4 LUMBER, WITH LUMBER ORIENTED VERTICALLY OR HORIZONTALLY. TRUSS MEMBERS SECURED TOGETHER WITH 0.0356 IN. THICK GALV STEEL PLATES. PLATES HAVE 5/16 IN. LONG TEETH PROJECTING PERPENDICULAR TO THE PLANE OF THE PLATE. THE TEETH ARE IN PAIRS FACING EACH OTHER (MADE BY THE SAME PUNCH), FORMING A SPLIT TOOTH TYPE PLATE. EACH TOOTH HAS A CHISEL POINT ON ITS OUTSIDE EDGE. THESE POINTS ARE DIAGONALLY OPPOSITE EACH OTHER FOR EACH PAIR, THE TOP HALF OF EACH TOOTH HAS A TWIST FOR STIFFNESS. THE PAIRS ARE REPEATED ON APPROXIMATELY 7/8 IN. CENTERS WITH FOUR ROWS OF TEETH PER INCH OF PLATE WIDTH. WHERE THE TRUSS INTERSECTS WITH THE INTERIOR FACE OF THE EXTERIOR WALLS, THE MIN TRUSS DEPTH SHALL BE 5-1/4 IN. WITH A MIN ROOF SLOPE OF 3/12 AND A MIN AREA IN THE PLANE OF THE TRUSS OF 21 SQ.FT. WHERE THE TRUSS INTERSECTS WITH THE INTERIOR FACE OF THE EXTERIOR WALLS, THE MIN TRUSS DEPTH MAY BE REDUCED TO 3 IN. IF THE BATTIS AND BLANKETS ( ITEM 3) ARE USED AS SHOWN IN THE ABOVE ILLUSTRATION (ALTERNATE INSULATION PLACEMENT) AND ARE FIRMLY PACKED AGAINST THE INTERSECTION OF THE BOTTOM CHORDS AND THE PLYWOOD SHEATHING.
3	GLASS FIBER OR MINERAL FIBER BATT OR LOOSE FILL INSULATION APPLIED DIRECTLY OVER GYPSUM BOARD. (R-38 BLOW-IN FIBERGLASS INSULATION (ONLY AT LIVING SPACES.))
4	RESILIENT CHANNELS - MIN 3/8 IN. DEEP BY MIN 2 IN. WIDE AT THE BASE AND MIN 1-1/4 IN. WIDE AT THE FACE, FORMED FROM 0.020 IN. THICK GALV STEEL, SPACED 12 IN. OC. CHANNELS SECURED TO EACH TRUSS WITH 1-1/4 IN. LONG TYPE S STEEL SCREWS. CHANNELS OVERLAPPED 4 IN. AT SPLICES.
5	(5/8" GOLD BOND BRAND FIRE-SHIELD C) - INSTALLED WITH LONG DIMENSION PERPENDICULAR TO RESILIENT CHANNELS WITH 1-1/8 IN. LONG TYPE S SCREWS SPACED 12 IN. OC AND LOCATED A MIN OF 1/2 IN. FROM SIDE JOINTS AND 3 IN. FROM THE END JOINTS. AT END JOINTS, TWO RESILIENT CHANNELS ARE USED, EXTENDING A MIN OF 6 IN. BEYOND BOTH ENDS OF THE JOINT. WHEN INSULATION, ITEM 3 OR 3A, IS DRAPED OVER THE RESILIENT CHANNEL GYPSUM WALLBOARD CEILING MEMBRANE, SCREWS SHALL BE INSTALLED AT 8 IN. OC.
6	NOTE: AT EXTERIOR ROOFS PROVIDE 1x4s AT 16" O.C. WITH CONTINUOUS VENTED VINYL SOFFIT (WHITE)
7	6 MIL. VAPOR BARRIER AT ALL HEATED SPACES
ACTUAL FIRE RESISTANCE RATING 1 HOUR FIRE	
SOUND RATING N/A	

### ROOF-CEILING ASSEMBLY

(1 HR TRUSSES)  
SCALE: 1-1/2"=1'-0"

(UL DESIGN NUMBER P533)  
T:\09\FINSH\2500\Y9PBD\09250188

NOTE:  
ALL ASSEMBLIES THIS SHEET MUST BE INSTALLED PER ASSEMBLY NUMBER LISTED ON DRAWING. ANY SUBSTITUTIONS TO ASSEMBLIES MUST BE SUBMITTED TO ARCHITECT FOR REVIEW AND APPROVAL. SUBJECT TO LOCAL APPROVAL

### ALTERNATE ATTACHMENT OPTION

SCREW TO BE USED IN PLACE OF NAILS IN ALL ASSEMBLIES AS ALLOWED BELOW

UL DESIGN INFORMATION SECTION SUPPLEMENTS THE INDIVIDUAL PUBLISHED DESIGNS:  
NAILS AND SCREWS:  
SCREWS MEETING ASTM C1002, "STANDARD SPECIFICATION FOR SELF-PERCING TAPPING SCREWS FOR THE APPLICATION OF GYPSUM PANEL PRODUCTS OR METAL PLASTER BASES TO WOOD STUDS OR STEEL STUDS," MAY BE SUBSTITUTED FOR NAILS, ONE FOR ONE, WHEN THE HEAD DIAMETER, LENGTHS, AND SPACING EQUAL OR EXCEED THE REQUIREMENTS FOR THE SPECIFIED NAILS.  
SCREWS MEETING ASTM C 1002 SHALL BE PERMITTED TO BE SUBSTITUTED FOR THE PRESCRIBED NAILS, ONE FOR ONE, WHEN THE LENGTH AND HEAD DIAMETER OF THE SCREWS EQUAL OR EXCEED THOSE OF THE NAILS SPECIFIED IN THE TESTED SYSTEM AND THE NAIL SPACING DOES NOT EXCEED THE SPACING SPECIFIED FOR THE NAILS IN THE TESTED SYSTEM.

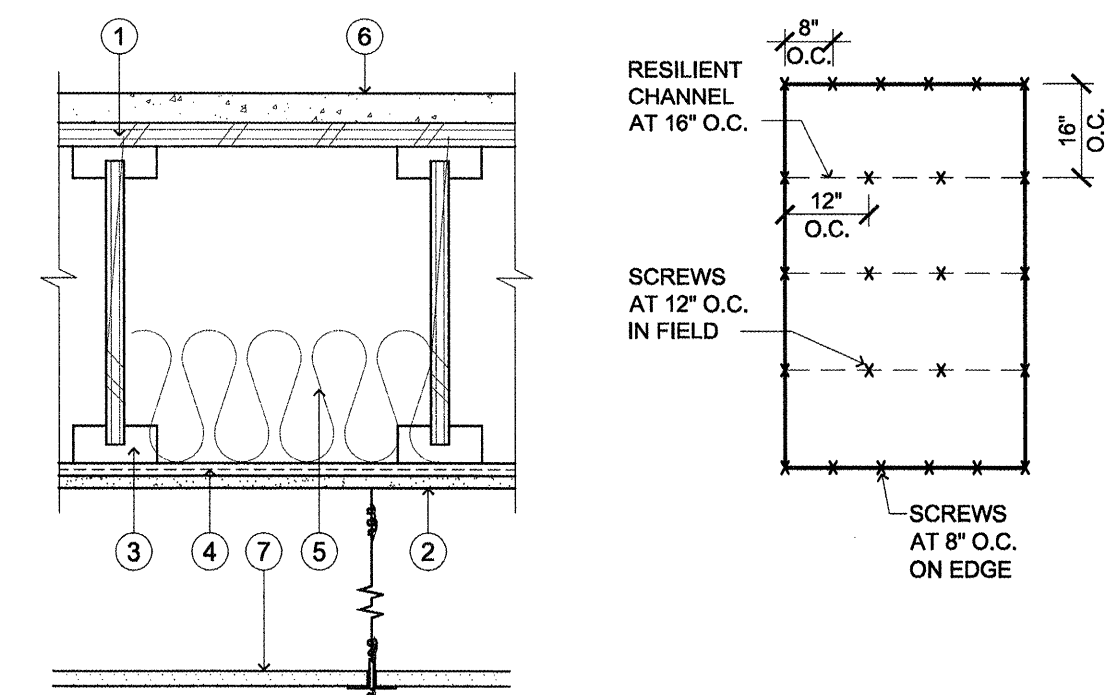

CONSTRUCTION ASSEMBLY	
AMERICAN WOOD COUNCIL - WJ-1.2	
NOTES	DESCRIPTION
1	FLOOR SHEATHING: MINIMUM 23/32" THICK TONGUE-AND-GROOVE WOOD SHEATHING (EXPOSURE 1), INSTALLED PER CODE REQUIREMENTS WITH MINIMUM 8d COMMON NAILS AND GLUED TO JOIST TOP FLANGES WITH AFG-01 CONSTRUCTION ADHESIVE.
2	GYPSUM WALLBOARD: MINIMUM 5/8" THICK TYPE "C" GYPSUM WALLBOARD INSTALLED WITH LONG DIMENSION PERPENDICULAR TO RESILIENT CHANNELS AND FASTENED TO EACH CHANNEL WITH MINIMUM 1" LONG TYPE S DRYWALL SCREWS, FASTENERS SPACED 12" ON CENTER IN THE FIELD OF THE WALLBOARD, 8" ON CENTER AT WALLBOARD END JOINTS, AND 3/4" FROM PANEL EDGES AND ENDS. END JOINTS OF WALLBOARD STAGGERED.
3	STRUCTURAL MEMBERS: WOOD I-JOISTS SPACED A MAXIMUM OF 24" O.C. MINIMUM I-JOIST JOIST DEPTH: 1-1/2" MINIMUM I-JOIST FLANGE AREA: 5.25 SQ. IN. MINIMUM I-JOIST WEB THICKNESS: 7/16" SEE ASTM D 5055-07 FOR QUALIFICATION REQUIREMENTS.
4	RESILIENT CHANNELS: MINIMUM 0.019" THICK GALVANIZED STEEL RESILIENT CHANNELS, ATTACHED PERPENDICULAR TO I-JOISTS USING 1-5/8" LONG DRYWALL SCREWS, RESILIENT CHANNELS SPACED 16" O.C. AND DOUBLED AT EACH WALLBOARD END JOINT EXTENDING TO THE NEXT JOINT.
5	INSULATION: MINIMUM 1-1/2" THICK MINERAL WOOL INSULATION BATTS - 2.5 P.F (NOMINAL), SUPPORTED BY RESILIENT CHANNELS.
ACTUAL FIRE RESISTANCE RATING 1 HOUR FIRE	
STC RATING 60 (WITH CEMENT TOPPING AND CARPET/PAD)	
FINISHES - OPTIONAL	
6	1" OF CEMENT TOPPING
7	SUSPENDED ACOUSTIC CEILING TILE (NON-RATED)

### FLOOR CEILING ASSEMBLY

(AWC WJ-1.2)  
SCALE: 1-1/2"=1'-0"

(AWC WJ-1.2)  
T:\09\FINSH\2500\Y9PBD\09250228

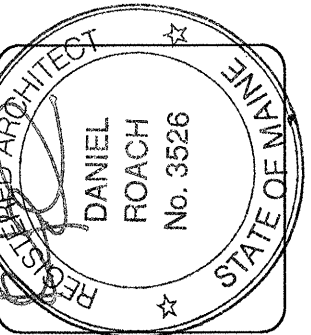

**lenity**  
architecture  
3150 Kettle Court, SE, Salem, Oregon 97302  
P: 503 399 1090 F: 503 399 0365  
W: lenityarchitecture.com

**COLSON AND COLSON**  
GENERAL CONTRACTOR, INC.  
2260 MCGILCHRIST STREET SE, SUITE 200  
SALEM, OREGON 97302  
PHONE (503) 586-7401

**PORTLAND**  
RETIREMENT RESIDENCE  
802 OCEAN AVE., PORTLAND, MAINE 04103

**FLOOR AND WALL TYPES**

DATE  
8/28/2015

REVISED DATE

SHEET

A7.1b