

18 CURB DETAIL (CURB / ASPHALT)
SCALE: 1 1/2" = 1'-0"

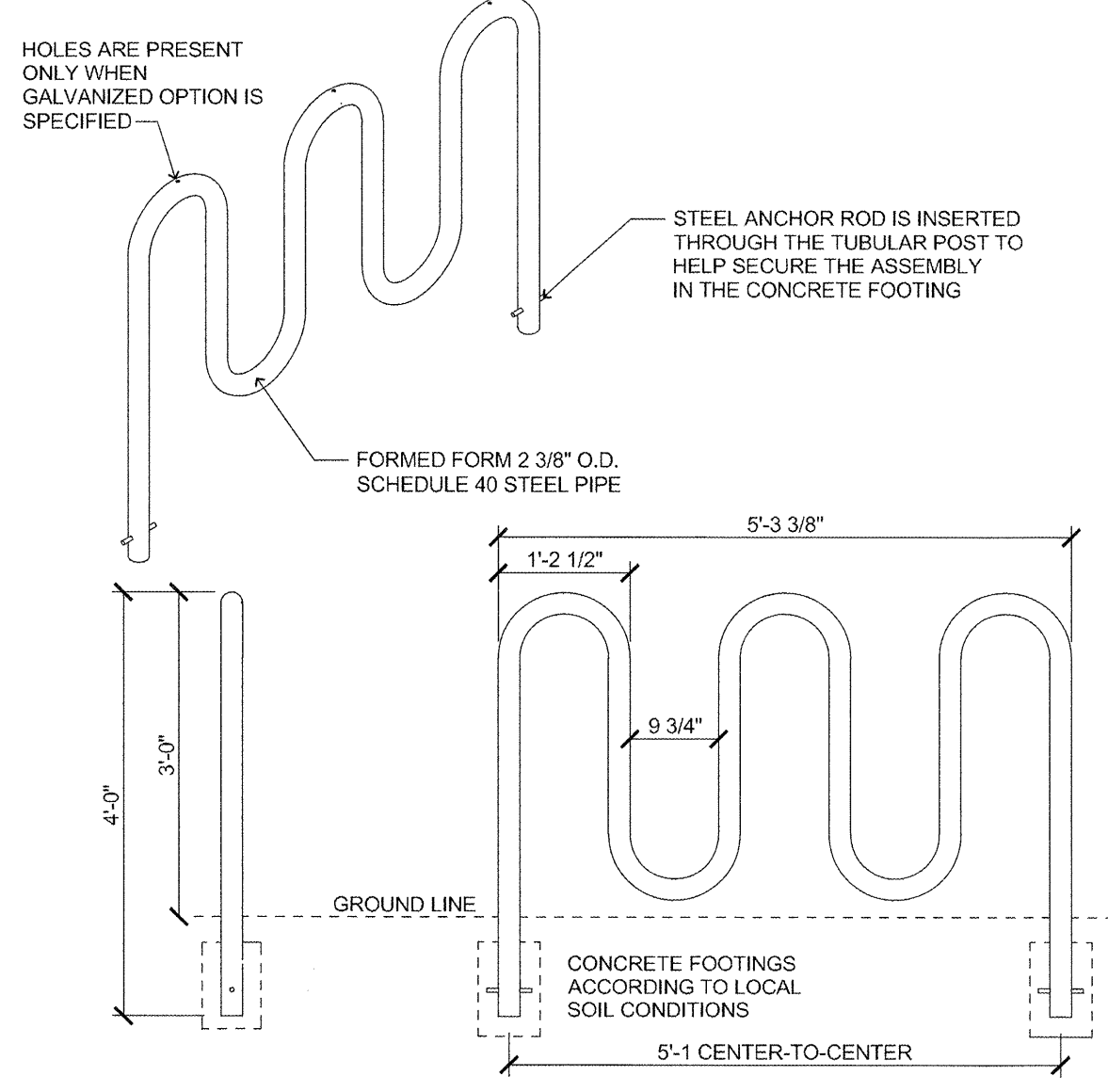

14 BIKE RACK (CYCLE SENTRY SERIES BRCS-105)
SCALE: NOT TO SCALE

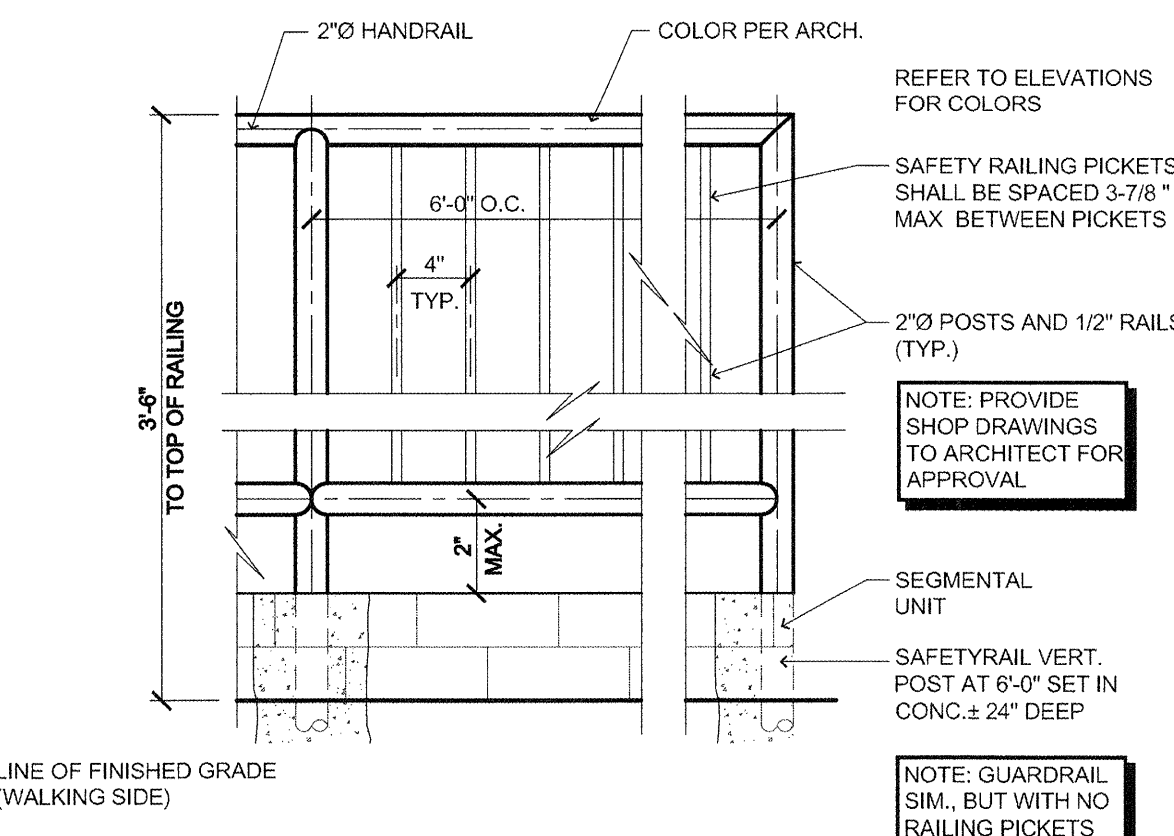

12 SAFETY RAILING DETAIL (WALL EDGES)
SCALE: 1" = 1'-0"

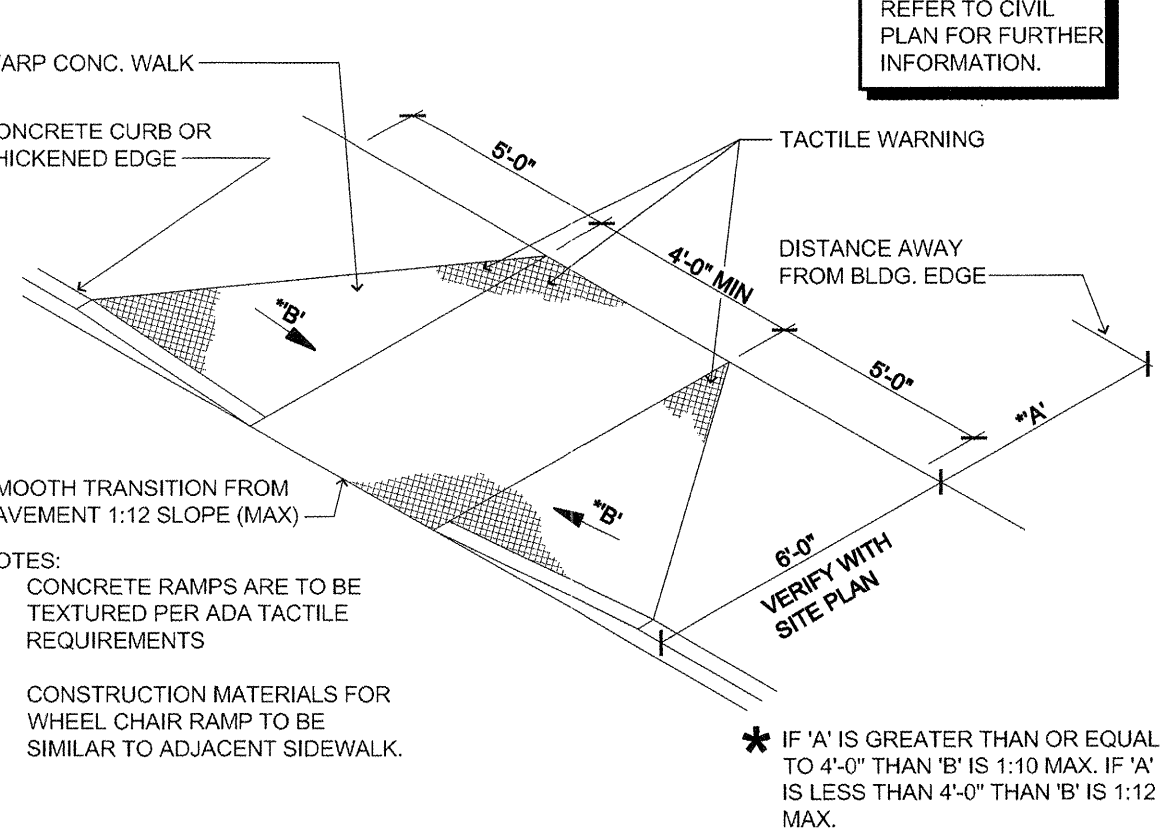

8 SIDEWALK DETAIL (ACCESS RAMP)
SCALE: NOT TO SCALE

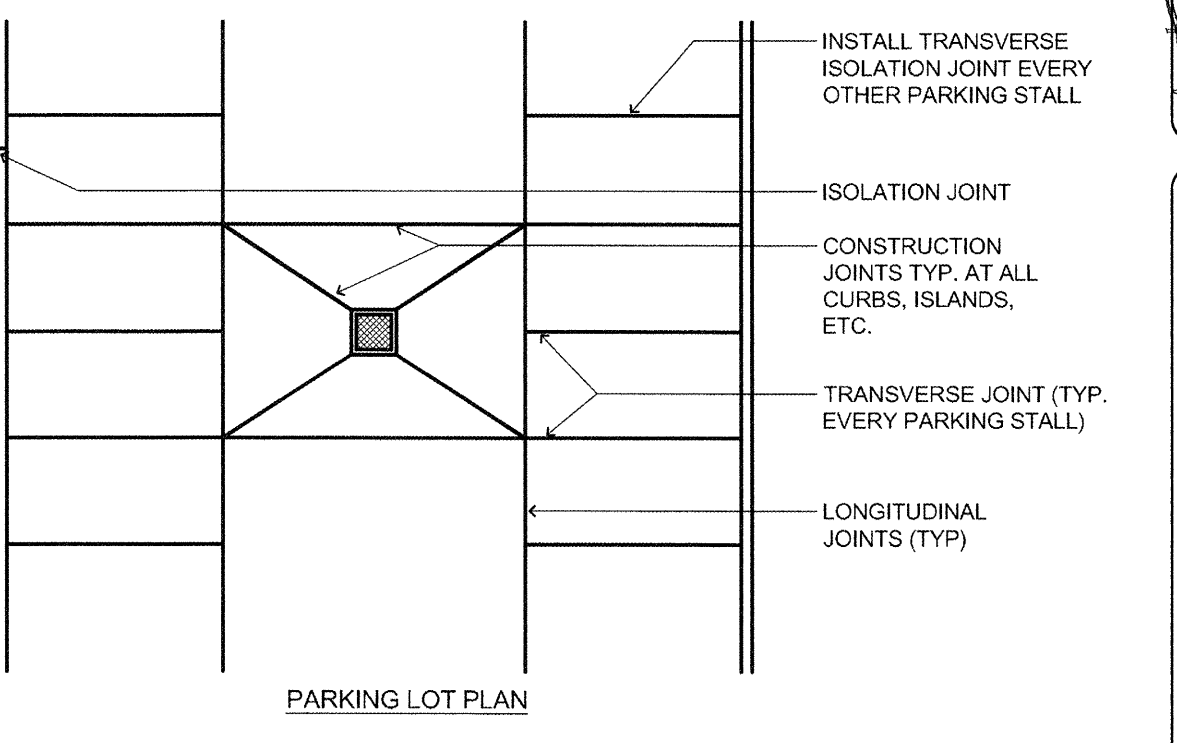

4 TYPICAL JOINT LAYOUT (ALTERNATE CONCRETE PARKING)
SCALE: NOT TO SCALE

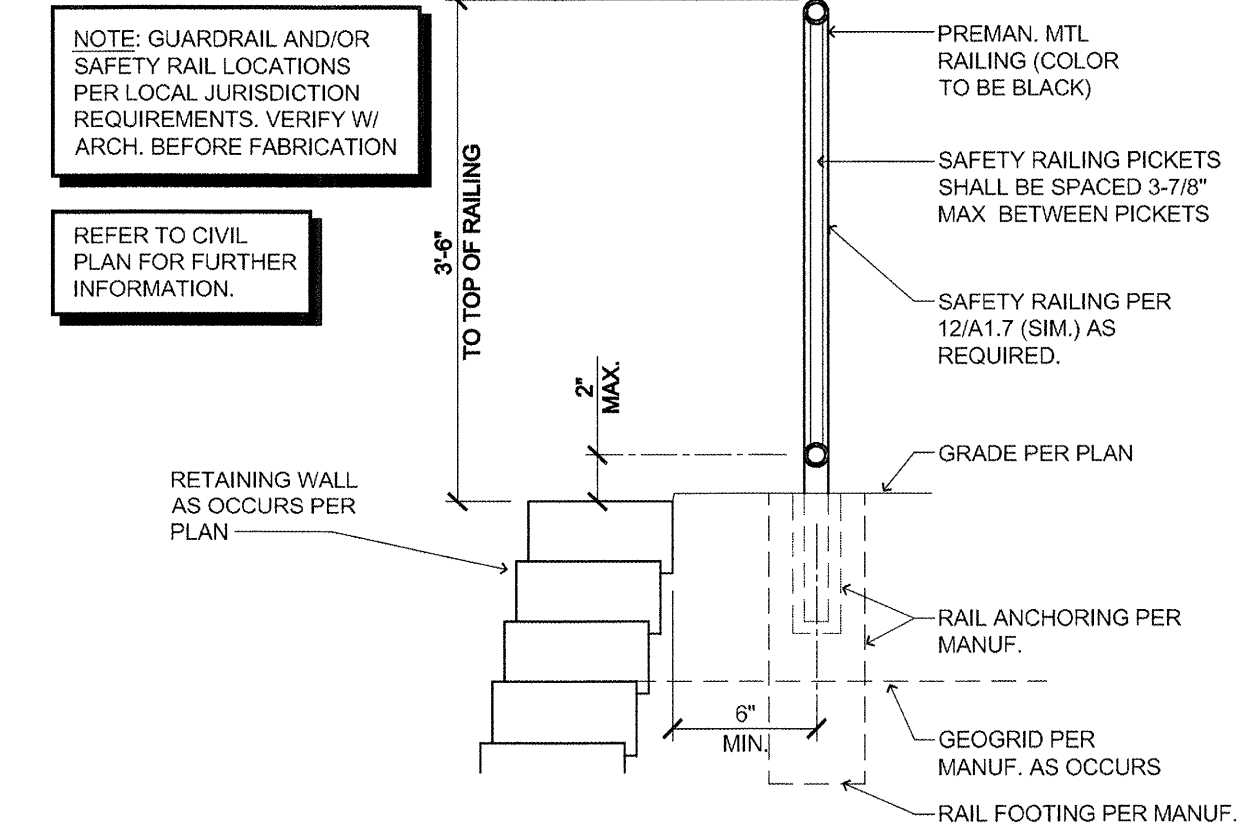

17 GUARD RAIL / SAFETY RAIL (SECTION)
SCALE: NOT TO SCALE

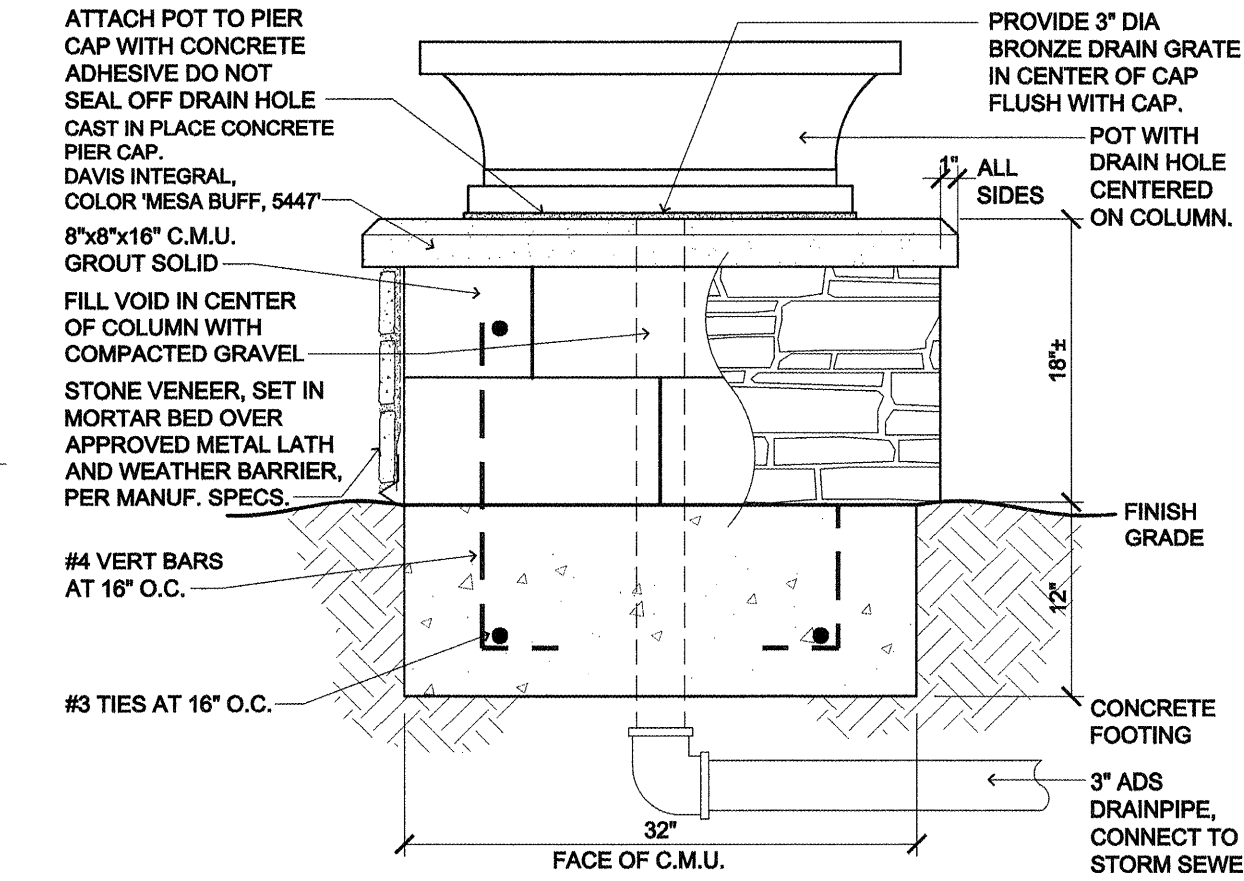

11 POTTERY COLUMN SECTION/ELEVATION (GARDEN)
SCALE: 1" = 1'-0"

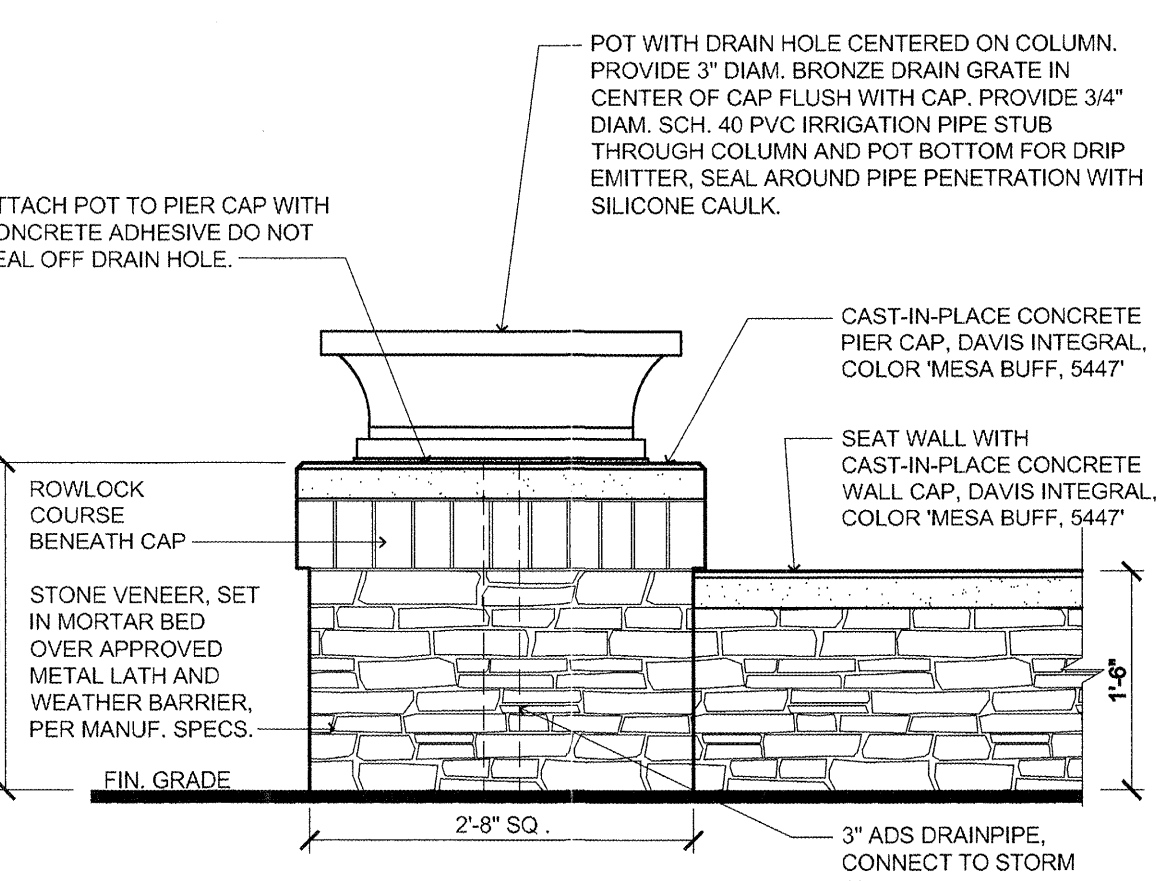

7 COLUMN / SEAT WALL
SCALE: 3/4" = 1'-0"

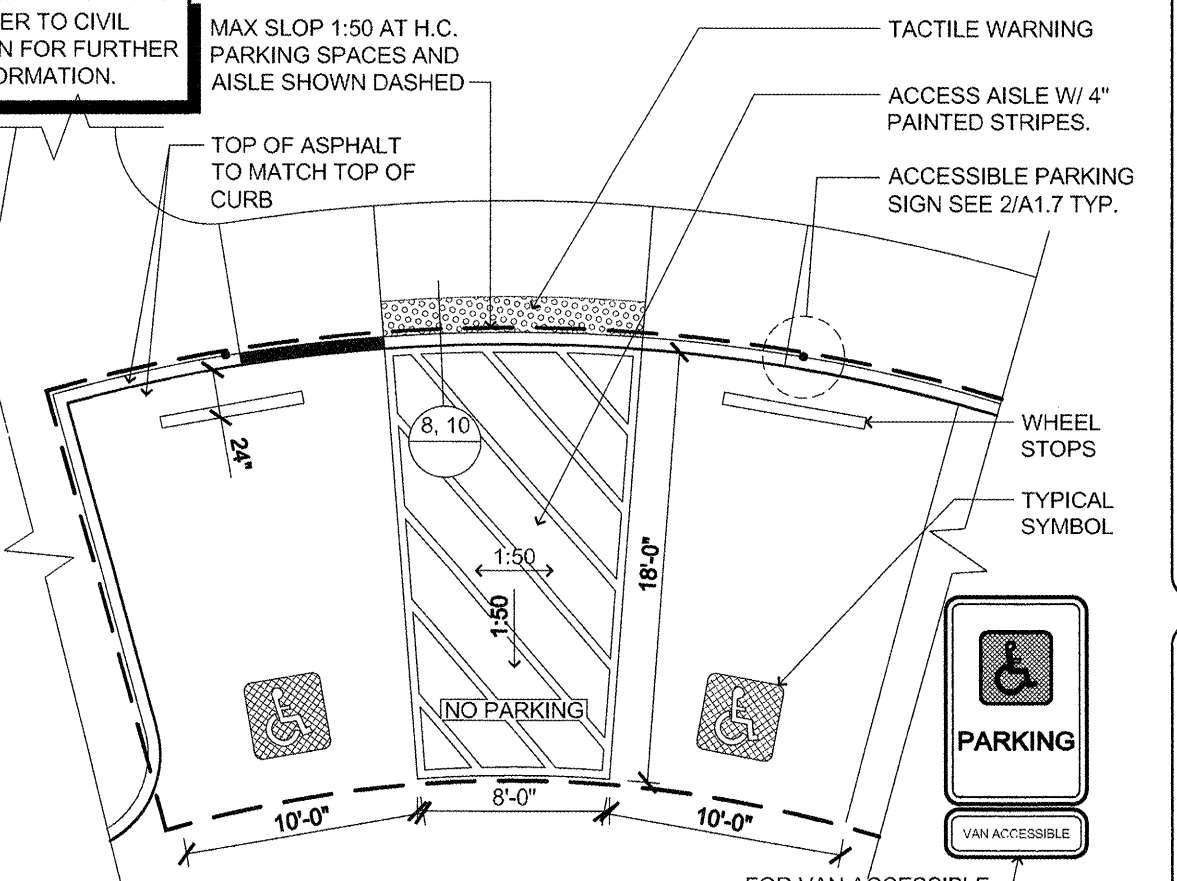

3 PARKING STALL
SCALE: 1/8" = 1'-0"

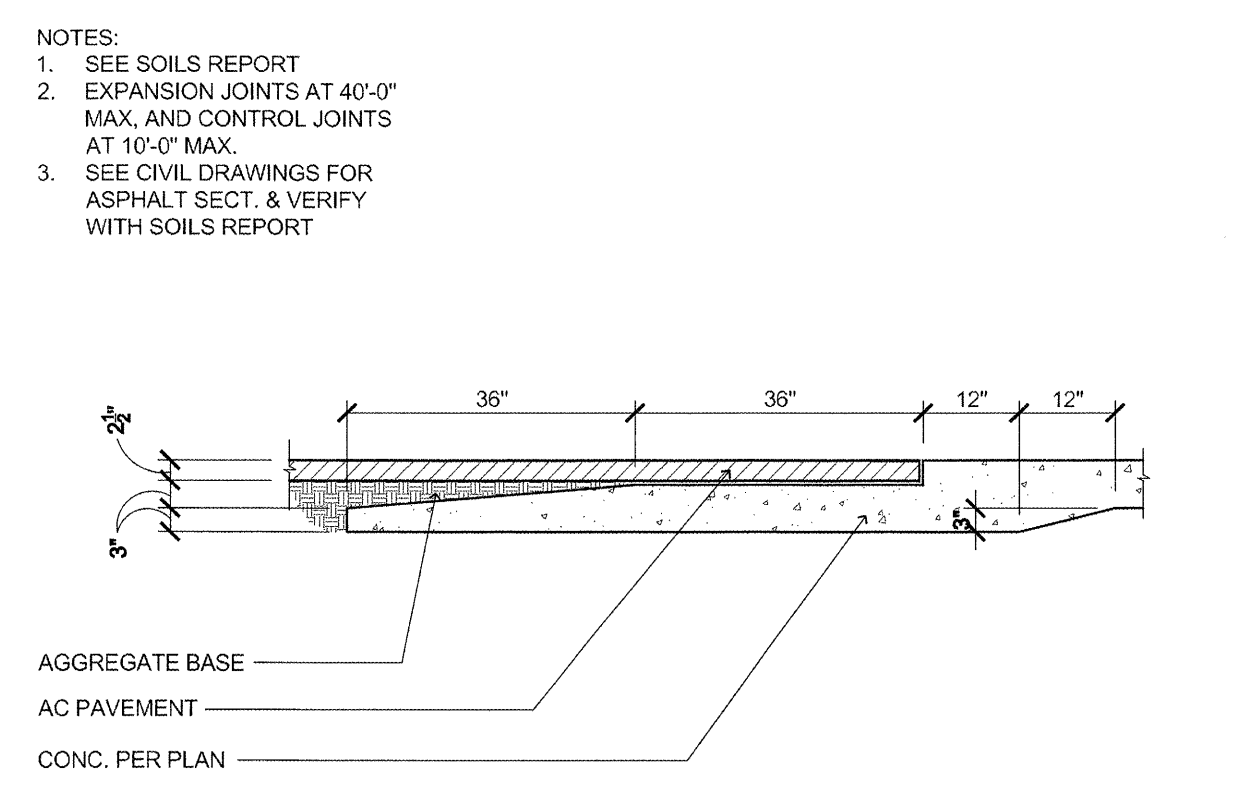

16 PAVEMENT TRANSITION (PAVEMENT AND CONCRETE)
SCALE: 1/2" = 1'-0"

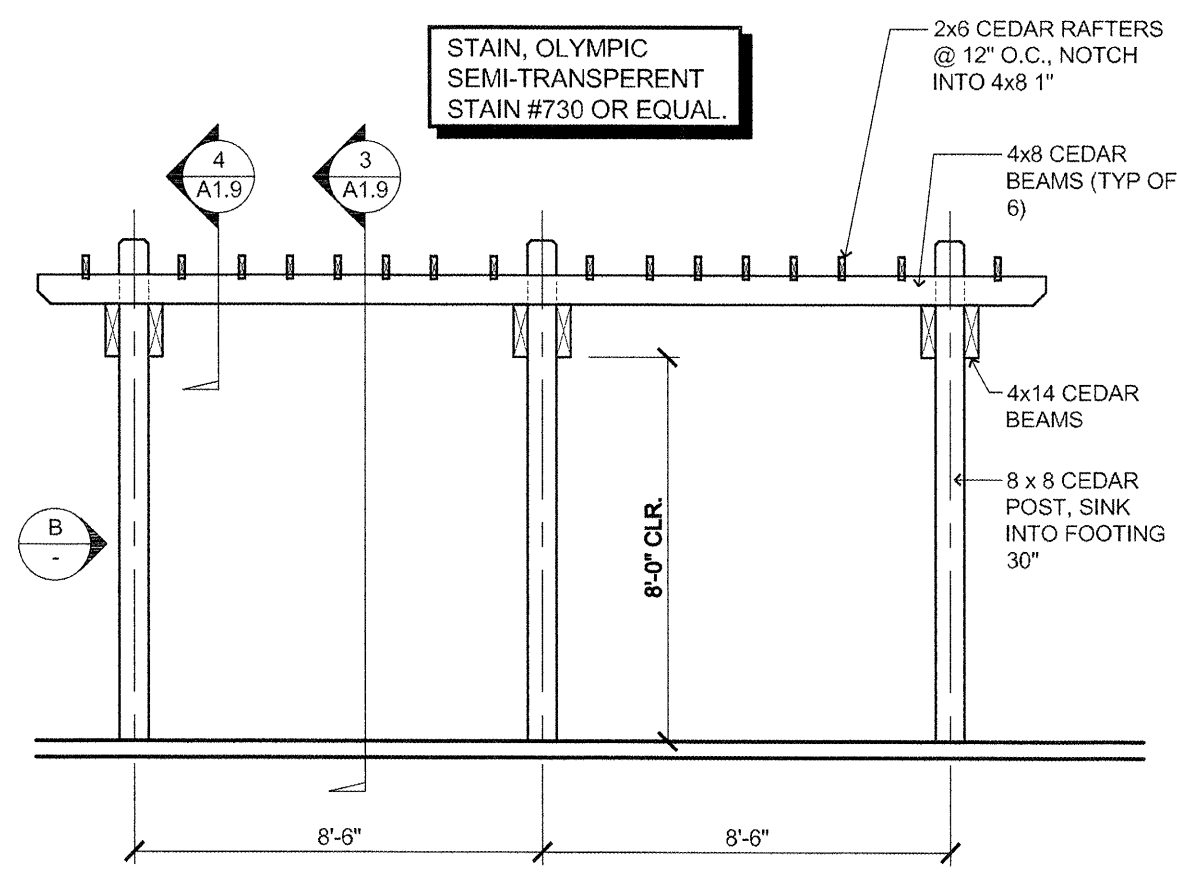

13 ARBOR ELEVATIONS
SCALE: 1/4" = 1'-0"

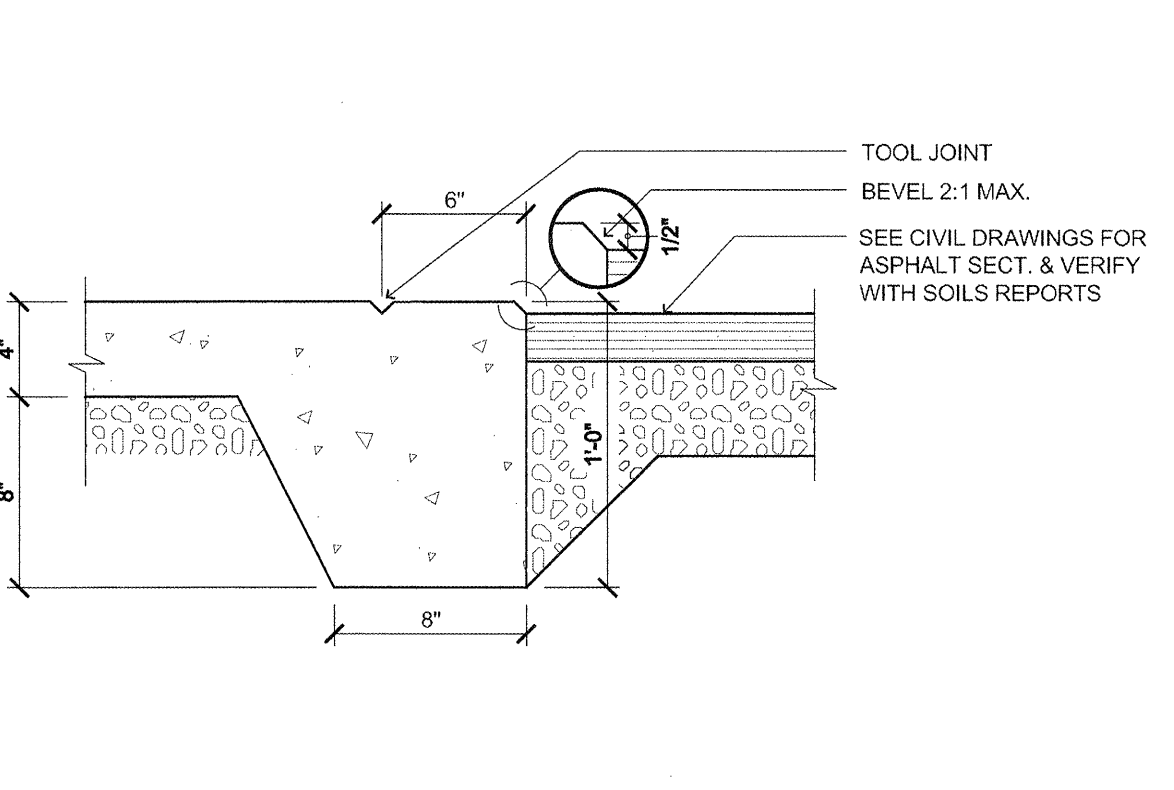

10 WALK DETAIL (WALK / PAVING AT ENTRY)
SCALE: 1 1/2" = 1'-0"

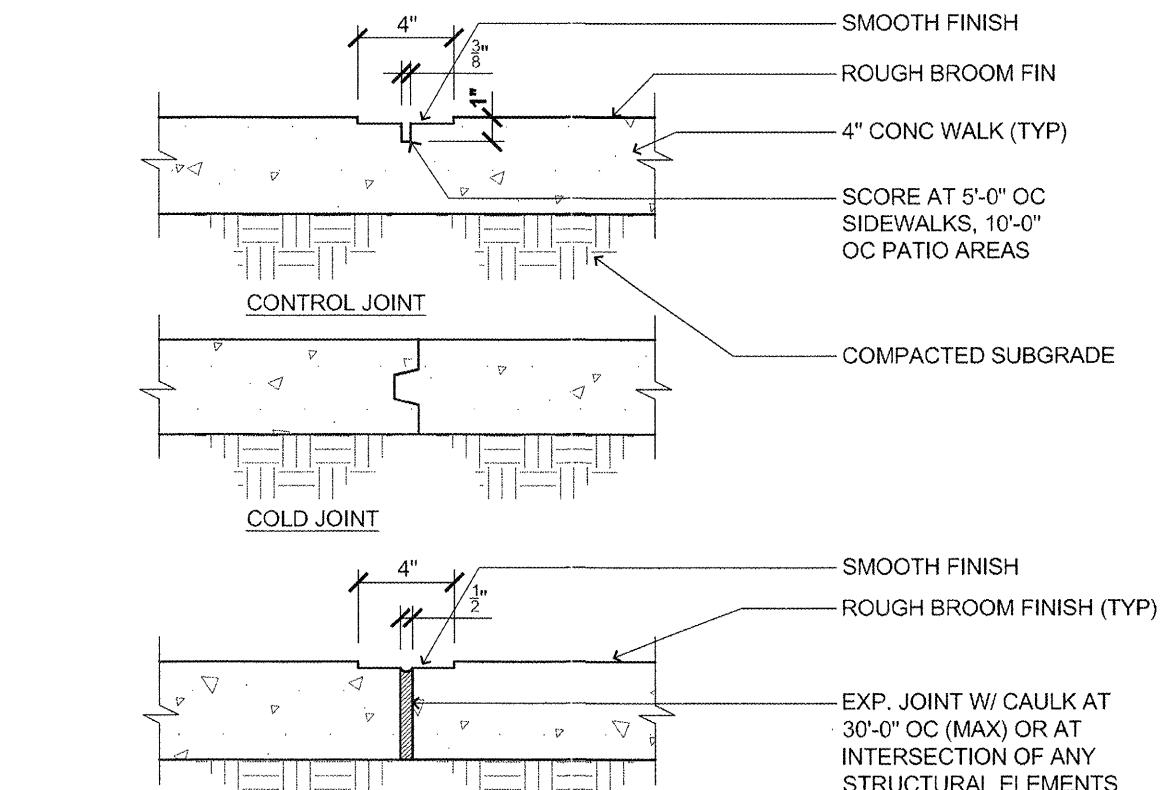

6 WALK/PATIO DETAIL (CONCRETE WALK JOINTS)
SCALE: 1 1/2" = 1'-0"

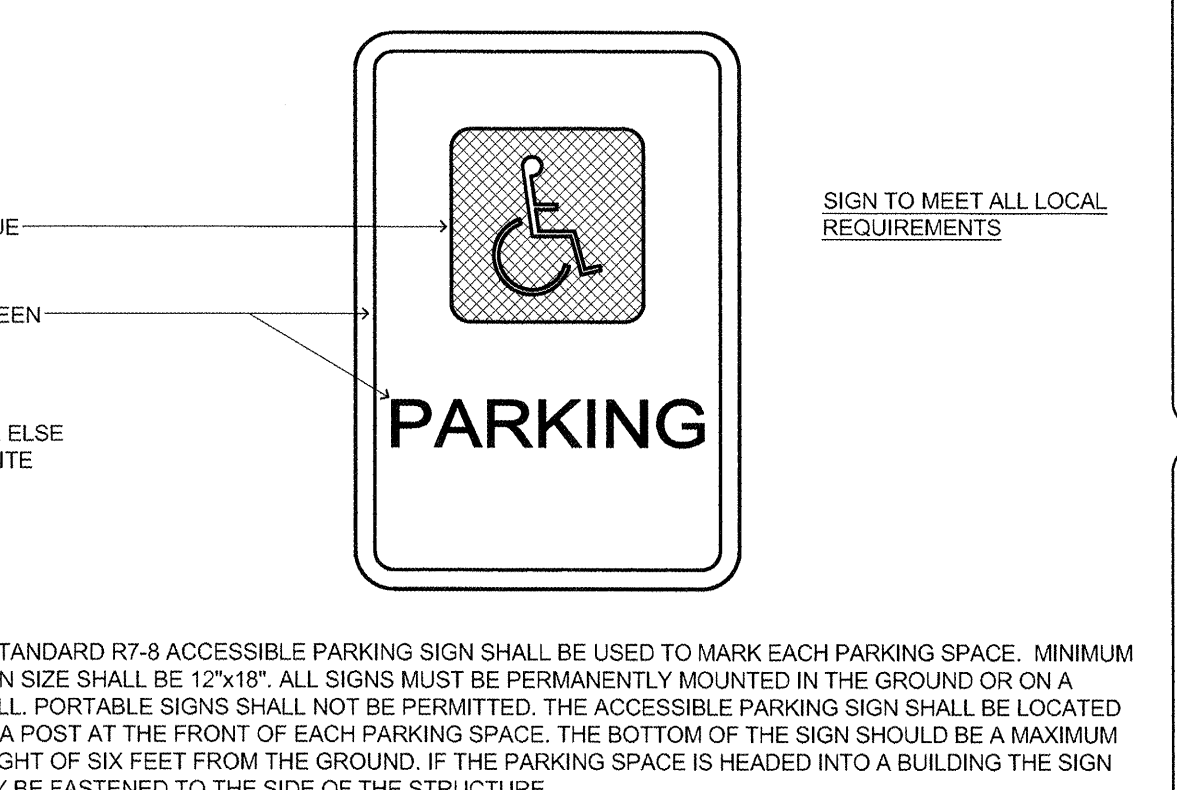

2 PARKING SIGN
SCALE: NOT TO SCALE

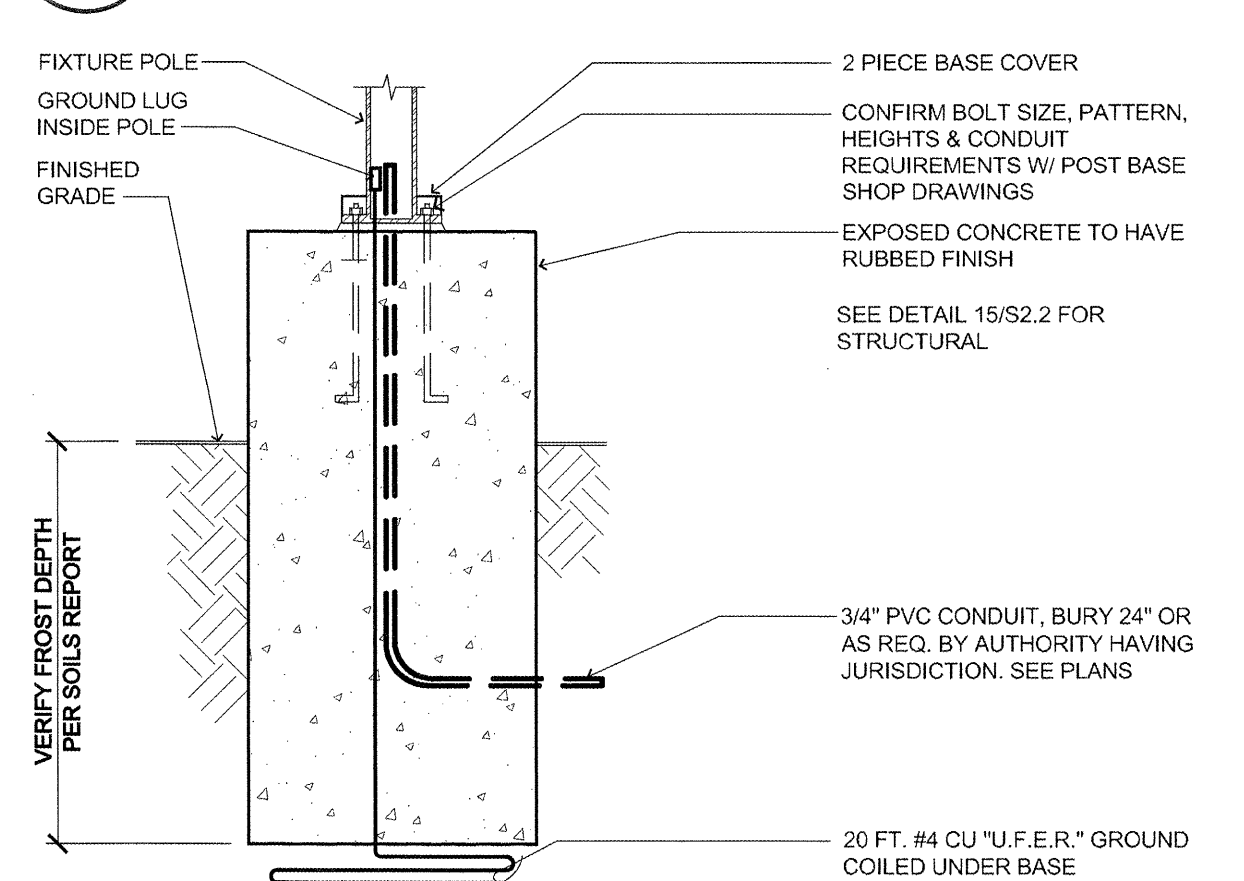

15 PARKING LOT LIGHT BASE
SCALE: 3/4" = 1'-0"

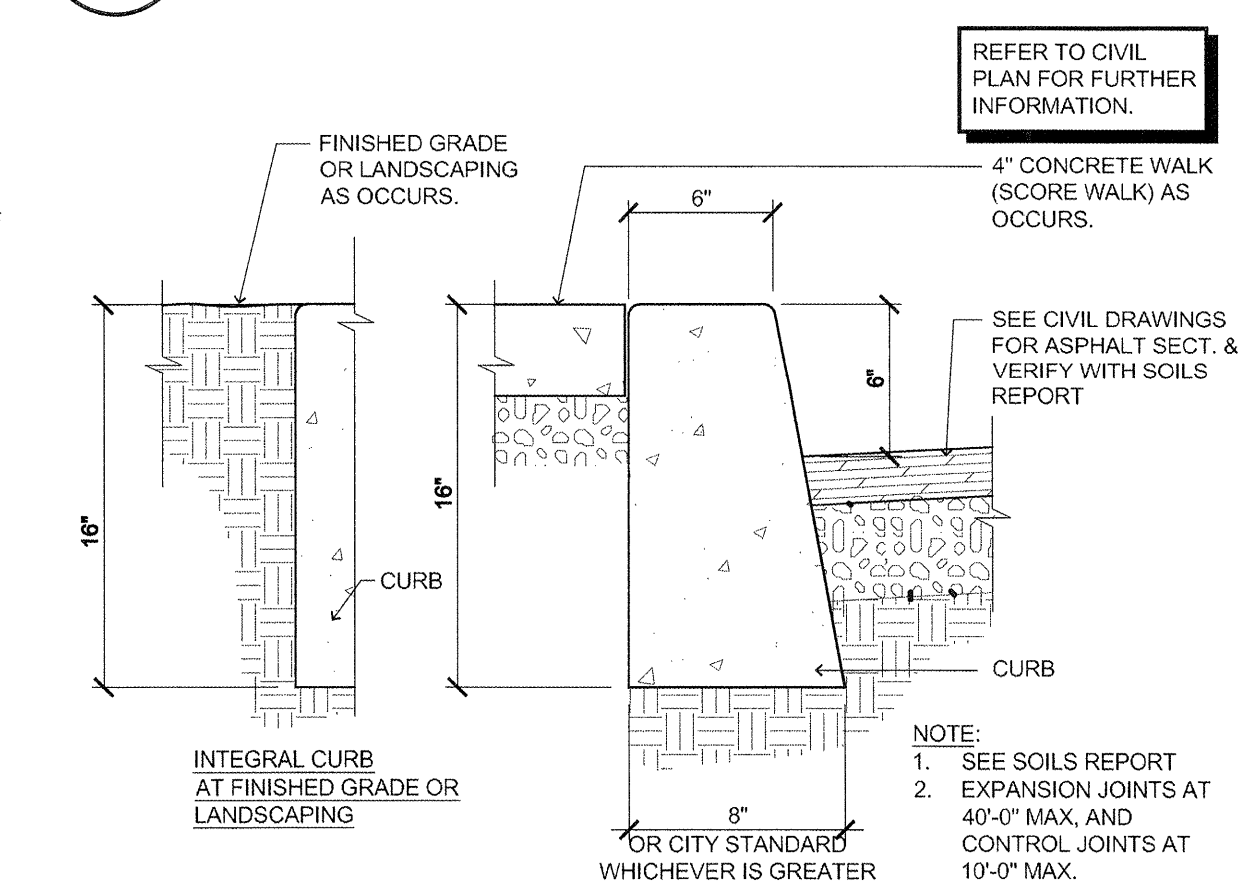

9 CURB DETAIL (SIDEWALK / CURB / ASPHALT)
SCALE: 1 1/2" = 1'-0"

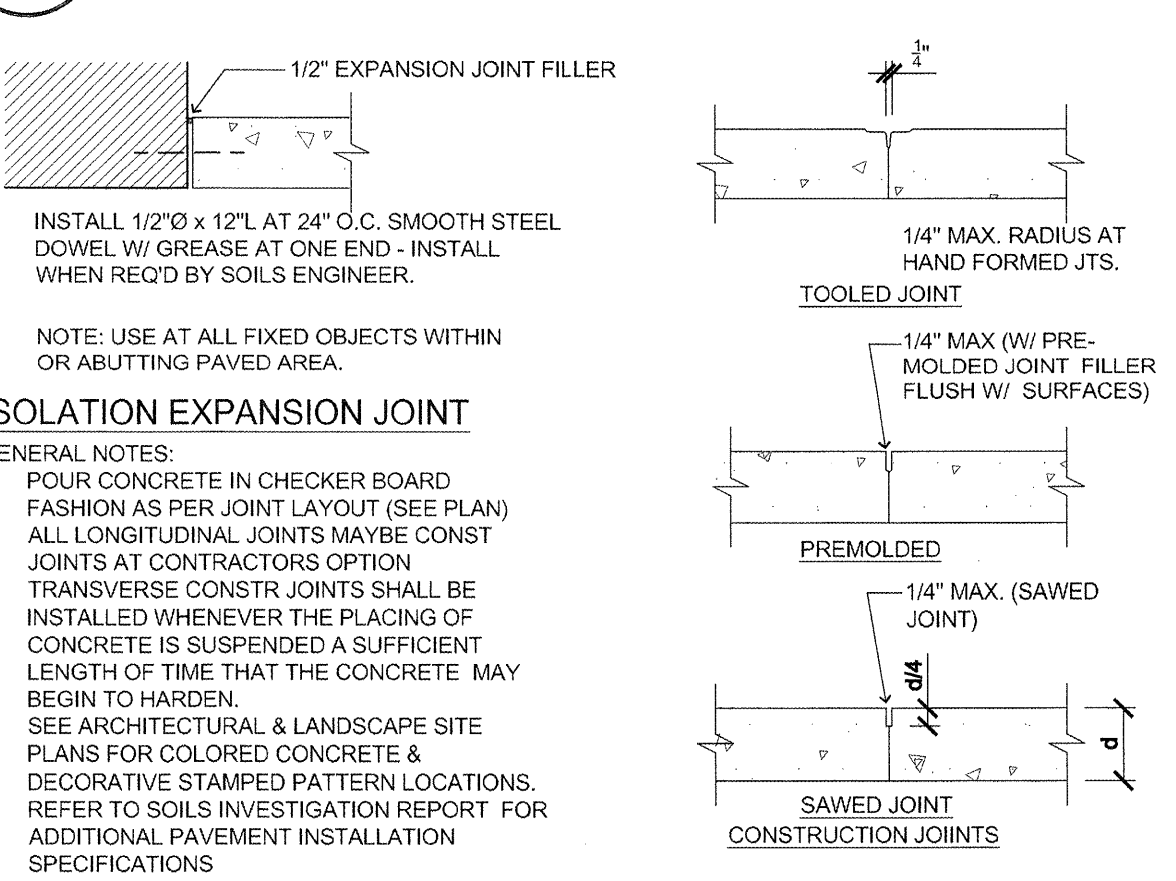

5 TYPICAL JOINT CONSTRUCTION (ALTERNATE CONCRETE PARKING)
SCALE: 1 1/2" = 1'-0"

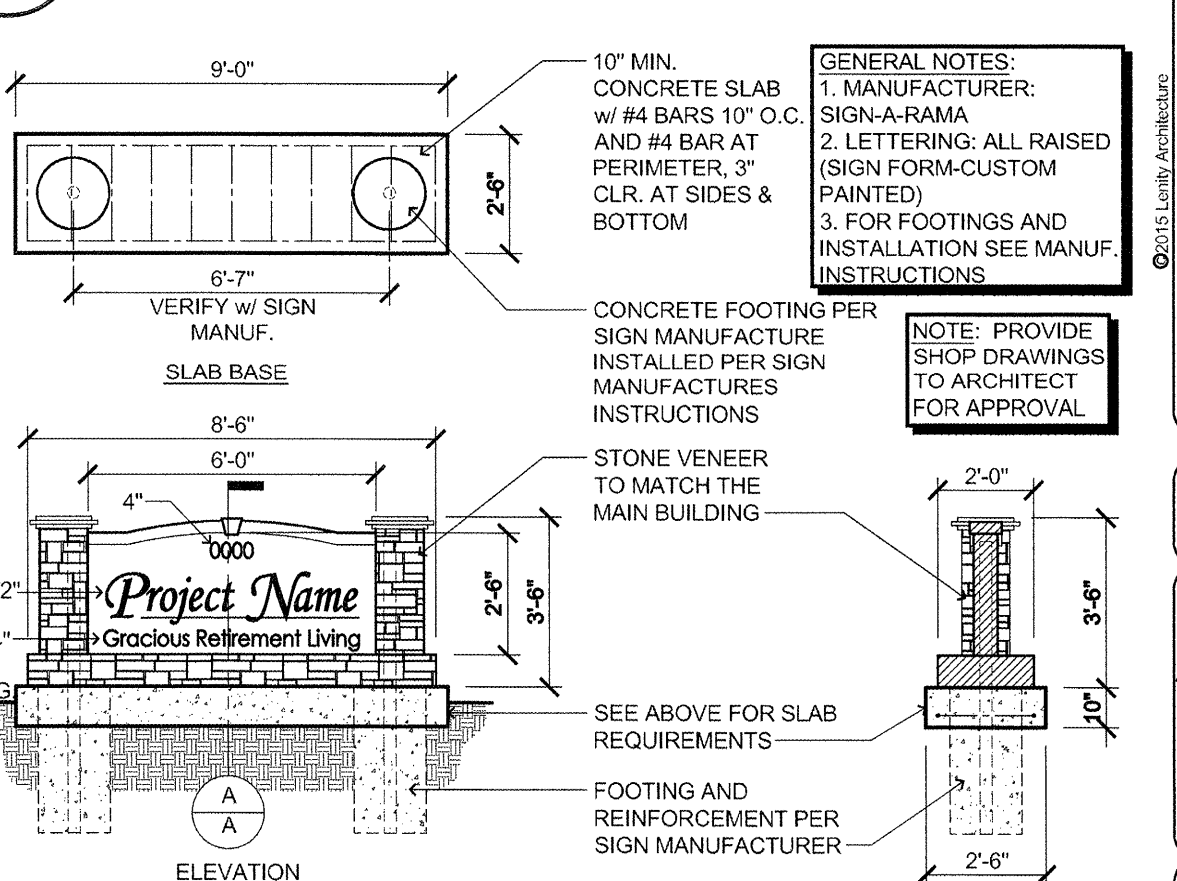

1 PROJECT SIGN (SEPARATE PERMIT REQUIRED)
SCALE: 1/4" = 1'-0"

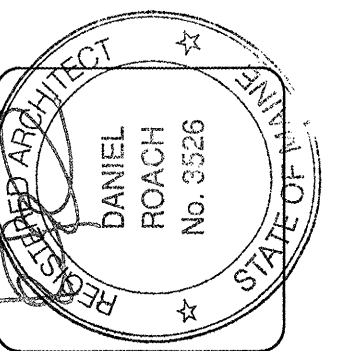

lenity architecture
3150 Lettie Court SE, Salem, Oregon 97301
Phone: 503.599.1090 Fax: 503.599.0585

COLSON AND COLSON GENERAL CONTRACTOR, INC.
2280 McCullum Street SE, Suite 200
Salem, Oregon, 97302
PHONE (503) 586-7401

PORTLAND RETIREMENT RESIDENCE
802 OCEAN AVE., PORTLAND, MAINE 04103

SITE DETAILS

DATE: 8/28/2015
REVISED DATE: 9/22/2015
SHEET: A1.7