

DISPLAY THIS CARD ON PRINCIPAL FRONTAGE OF WORK



# CITY OF PORTLAND

# BUILDING PERMIT

This is to certify that DAVID E & BUTLAND

Located At 51 RAY ST

Job ID: 2012-09-5043-HVAC

CBL: 409- J-009-001

has permission to Firebird Heating System

provided that the person or persons, firm or corporation accepting this permit shall comply with all of the provisions of the Statues of Maine and of the Ordinances of the City of Portland regulating the construction, maintenance and use of the buildings and structures, and of the application on file in the department.

Notification of inspection and written permission procured before this building or part thereof is lathed or otherwise closed-in. 48 HOUR NOTICE IS REQUIRED.

A final inspection must be completed by owner before this building or part thereof is occupied. If a certificate of occupancy is required, it must be

A handwritten signature in black ink, appearing to be "J. [unclear]", written over a horizontal line.

**Fire Prevention Officer**

**Code Enforcement Officer / Plan Reviewer**

**THIS CARD MUST BE POSTED ON THE STREET SIDE OF THE PROPERTY  
PENALTY FOR REMOVING THIS CARD**

## BUILDING PERMIT INSPECTION PROCEDURES

Please call 874-8703 or 874-8693 (ONLY)

or email: [buildinginspections@portlandmaine.gov](mailto:buildinginspections@portlandmaine.gov)

With the issuance of this permit, the owner, builder or their designee is required to provide adequate notice to the city of Portland Inspections Services for the following inspections. Appointments must be requested 48 to 72 hours in advance of the required inspection. The inspection date will need to be confirmed by this office.

- **Please read the conditions of approval that is attached to this permit!! Contact this office if you have any questions.**
- **Permits expire in 6 months. If the project is not started or ceases for 6 months.**
- **If the inspection requirements are not followed as stated below additional fees may be incurred due to the issuance of a "Stop Work Order" and subsequent release to continue.**

The project cannot move to the next phase prior to the required inspection and approval to continue, REGARDLESS OF THE NOTICE OF CIRCUMSTANCES.

IF THE PERMIT REQUIRES A CERTIFICATE OF OCCUPANCY, IT MUST BE PAID FOR AND ISSUED TO THE OWNER OR DESIGNEE BEFORE THE SPACE MAY BE OCCUPIED.



# PORTLAND MAINE

*Strengthening a Remarkable City, Building a Community for Life • [www.portlandmaine.gov](http://www.portlandmaine.gov)*

Director of Planning and Urban Development  
Jeff Levine

Job ID: 2012-09-5043-HVAC

Located At: 51 RAY ST

CBL: 409- J-009-001

## **Conditions of Approval:**

### **Building**



Equipment shall be installed in compliance with the manufacturer's specifications and the UL listing.

**City of Portland, Maine - Building or Use Permit Application**

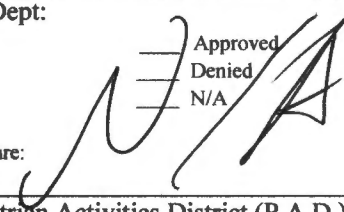
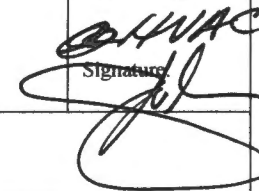
389 Congress Street, 04101 Tel: (207) 874-8703, FAX: (207) 8716

Job No: 2012-09-5043-HVAC	Date Applied: 9/26/2012	CBL: 409- J-009-001	
Location of Construction: 51-57 RAY ST	Owner Name: TOM & SARA LONG	Owner Address: 57 RAY STREET PORTLAND, ME 04103	Phone:
Business Name:	Contractor Name: Dan Libby Refrigerator/Heating	Contractor Address: 271 MILT BROWN RD STANDISH MAINE 04084	Phone: 640-4768
Lessee/Buyer's Name:	Phone:	Permit Type: HVAC	Zone: R-3
Past Use: Single Family Dwelling	Proposed Use: Same: Single Family Dwelling - to install Firebird heating system	Cost of Work: \$8,000.00	CEO District:
		Fire Dept:  Approved Denied N/A	Inspection: Use Group: R-3 Type: SB
		Signature: 	
Proposed Project Description: Firebird Heating System		Pedestrian Activities District (P.A.D.)	
Permit Taken By: Gayle	<b>Zoning Approval</b>		

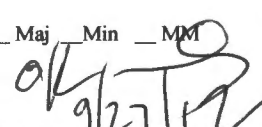
1. This permit application does not preclude the Applicant(s) from meeting applicable State and Federal Rules.
2. Building Permits do not include plumbing, septic or electrical work.
3. Building permits are void if work is not started within six (6) months of the date of issuance. False informatin may invalidate a building permit and stop all work.

Special Zone or Reviews	Zoning Appeal	Historic Preservation
<input type="checkbox"/> Shoreland	<input type="checkbox"/> Variance	<input checked="" type="checkbox"/> Not in Dist or Landmark
<input type="checkbox"/> Wetlands	<input type="checkbox"/> Miscellaneous	<input type="checkbox"/> Does not Require Review
<input type="checkbox"/> Flood Zone	<input type="checkbox"/> Conditional Use	<input type="checkbox"/> Requires Review
<input type="checkbox"/> Subdivision	<input type="checkbox"/> Interpretation	<input type="checkbox"/> Approved
<input type="checkbox"/> Site Plan	<input type="checkbox"/> Approved	<input type="checkbox"/> Approved w/Conditions
	<input type="checkbox"/> Denied	<input type="checkbox"/> Denied
___ Maj ___ Min ___ MM		
Date: 	Date:	Date: 

**CERTIFICATION**

I hereby certify that I am the owner of record of the named property, or that the proposed work is authorized by the owner of record and that I have been authorized by the owner to make this application as his authorized agent and I agree to conform to all applicable laws of this jurisdiction. In addition, if a permit for work described in the application is issued, I certify that the code official's authorized representative shall have the authority to enter all areas covered by such permit at any reasonable hour to enforce the provision of the code(s) applicable to such permit.

SIGNATURE OF APPLICANT	ADDRESS	DATE	PHONE
RESPONSIBLE PERSON IN CHARGE OF WORK, TITLE		DATE	PHONE



FILL IN AND SIGN WITH INK

# APPLICATION FOR PERMIT HEATING OR POWER EQUIPMENT

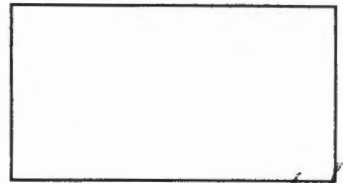

2012 09 5043 66  
R-3

To the INSPECTOR OF BUILDINGS, PORTLAND, ME.

The undersigned hereby applies for a permit to install the following heating, cooking or power equipment in accordance with the Laws of Maine, the Building Code of the City of Portland, and the following specifications:

Location / CBL 57 Ray Street <sup>31</sup> Use of Building Residential Date 9-25-12  
 Name and address of owner of appliance Tom & Sara Long  
57 Ray Street  
 Installer's name and address Dan Libby Portland  
271 Milt Brown Rd - Standish, Me Telephone 207-640-4768  
04084 207-318-6869

**Location of appliance:**  
 Basement       Floor  
 Attic             Roof

**Type of Fuel:**  
 Gas             Oil             Solid

**Appliance Name:** Firebird

U.L. Approved  Yes  No

Will appliance be installed in accordance with the manufacture's installation instructions?  Yes  No

IF NO Explain: \_\_\_\_\_

RECEIVED  
 SEP 26 2012  
 Dept. of Building Inspections  
 City of Portland Maine

**Type of Chimney:**  
 Masonry Lined  
 Factory built Liner in chimney  
 Metal  
 Factory Built U.L. Listing # \_\_\_\_\_  
 Direct Vent  
 Type \_\_\_\_\_ UL# \_\_\_\_\_

**Type of Fuel Tank** did not change  
 Oil  
 Gas

**Size of Tank** 275

**Number of Tanks** 1

**Distance from Tank to Center of Flame** 8' feet.

**Cost of Work:** \$ 8000.

**Permit Fee:** \$ \_\_\_\_\_

**The Type of License of Installer:**  
 Master Plumber # \_\_\_\_\_  
 Solid Fuel # \_\_\_\_\_  
 Oil # MS20005654  
 Gas # PNT 56  
 Other \_\_\_\_\_

Approved

Approved with Conditions

Fire: \_\_\_\_\_  
 Ele.: \_\_\_\_\_  
 Bldg.: \_\_\_\_\_

See attached letter or requirement

Signature of Installer Daniel Libby

Inspector's Signature

Date Approved

White - Inspection    Yellow - File    Pink - Applicant's    Gold - Assessor's Copy



# PORTLAND MAINE

*Strengthening a Remarkable City, Building a Community for Life • [www.portlandmaine.gov](http://www.portlandmaine.gov)*

Receipts Details:

**Tender Information:** Check , BusinessName: Dan Libby, Check Number: 8027  
**Tender Amount:** 100.00

Receipt Header:

**Cashier Id:** gguertin  
**Receipt Date:** 9/26/2012  
**Receipt Number:** 48647

Receipt Details:

Referance ID:	8145	Fee Type:	BP-Constr
Receipt Number:	0	Payment Date:	
Transaction Amount:	100.00	Charge Amount:	100.00
Job ID: Job ID: 2012-09-5043-HVAC - Firebird Heating System			
Additional Comments: 57 Ray St., Dan Libby			

Thank You for your Payment!

RECEIVED

SEP 26 2012

Dept. of Building Inspections  
City of Portland Maine

*An rogha is fearr*

# FIREBIRD

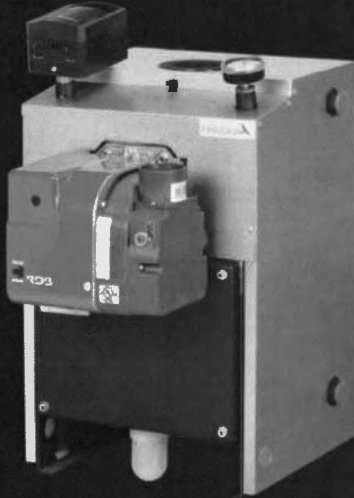

**Popular**  
(open casing design)

**Oil Condensing  
Boiler**

**91.5%**

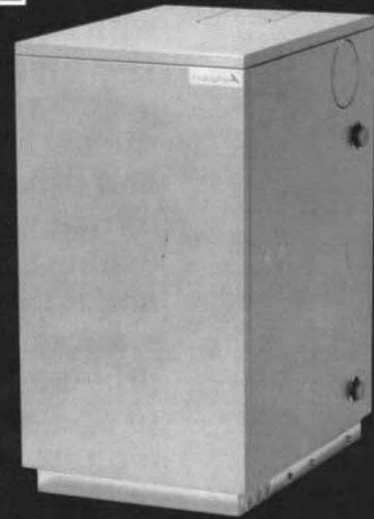

**Utility**  
(enclosed casing design)

- **Ultra quiet, high efficiency condensing boiler**
  - **Outputs ranging from 80 to 121 MBH**
    - **ASME certified heat exchanger**
  - **Constructed of mild & stainless steel**
  - **High performance Riello RDB burner**
    - **Extremely low stack temperature**

Imported and Distributed by:

**QHT**  
INCORPORATED

*Working towards a greener planet*

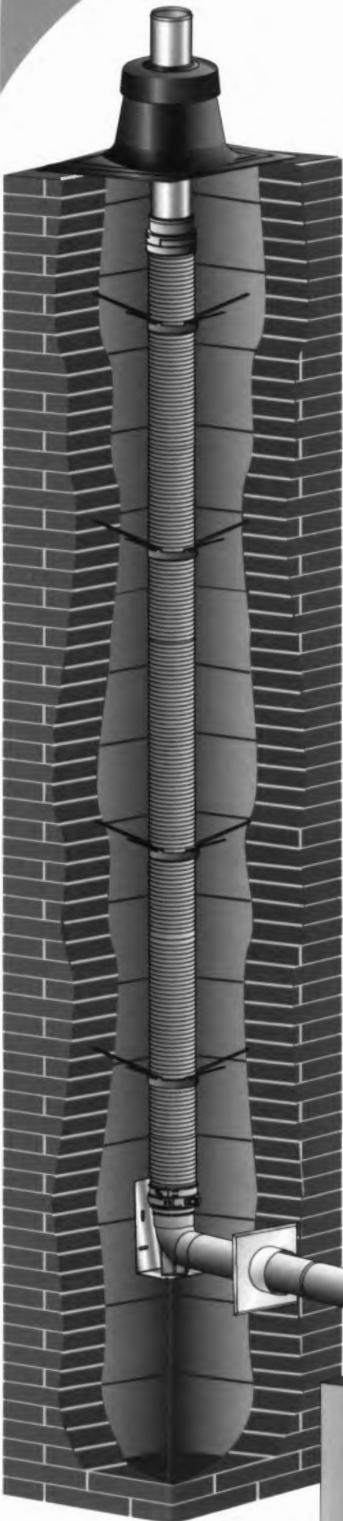

Polypropelene Chimney Liner Kit

Firebird's oil-fired, low mass, condensing boiler achieves an AFUE rating of 91.5% with a patented, down flue heat exchanger. This unique heat exchanger utilizes premium grade mild and stainless steel for the perfect combination of heat transfer and corrosion resistance properties. The intricate flue passage design slows the exhaust gases, maximizing heat transfer and efficiency while yielding an ultra low stack temperature. The Riello RDB burner provides the high static pressure required to operate this boiler. This system is the highest efficiency oil boiler in the industry, utilizing a yellow flame burner.

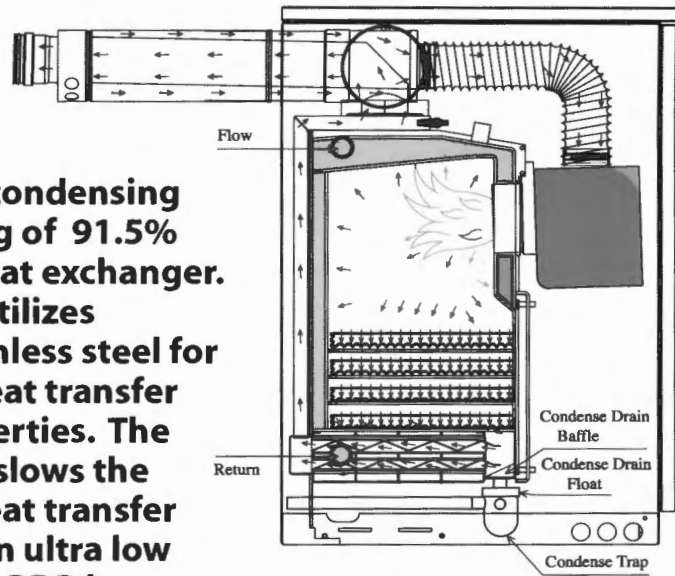

Down Flue Heat Exchanger

Model	Size	Heating Capacity (MBH)	Efficiency AFUE	Height (in)	Width (in)	Casing Length (in)	Weight (LBS)	Water Content (Gal)
Popular	P 90	80 / 95	91.5%	27	17.5	15	247	6
	P 120	105 / 121	90.7%				254	
Utility	U 90	80 / 95	91.5%	33.5		24	282	
	U 120	105 / 121	90.7%				288	

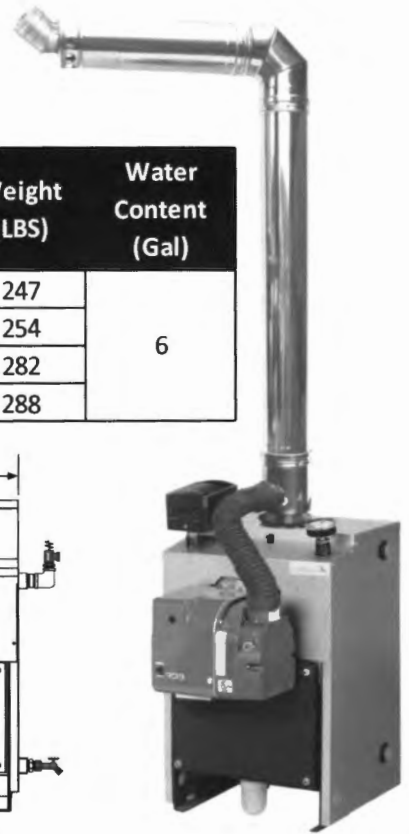
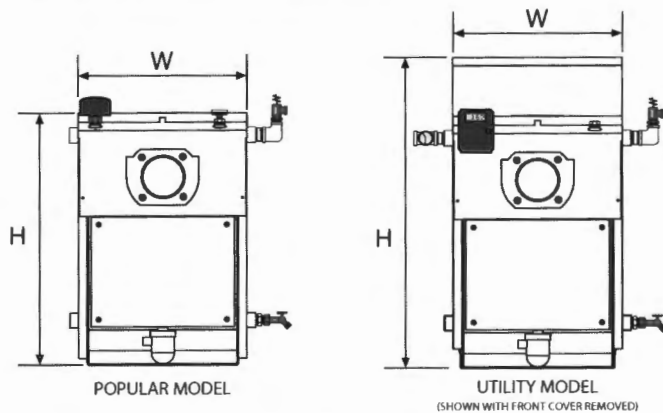

Concentric Side Wall Vent Kit

## QHT, INC.

3560 Lafayette Rd, Portsmouth, NH 03801  
 t: 800-501-7697 f: 877-334-6401 e: info@qhtinc.com

[www.firebirdboilers.us](http://www.firebirdboilers.us)

