

Typical Foundation size is 8" x 16"

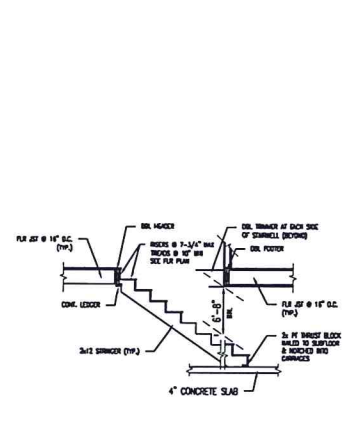

NOTE:
1. SUBSTITUTE RAFTER, CL. JSTS & STUD WALL SIZES WITH PLAN CALL OUT

TYPICAL STAIR FRAMING
N.T.S.

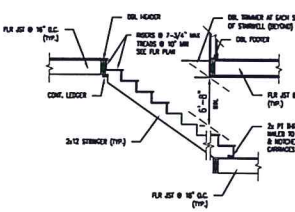

NOTE:
1. SUBSTITUTE RAFTER, CL. JSTS & STUD WALL SIZES WITH PLAN CALL OUT

TYPICAL STAIR FRAMING
N.T.S.

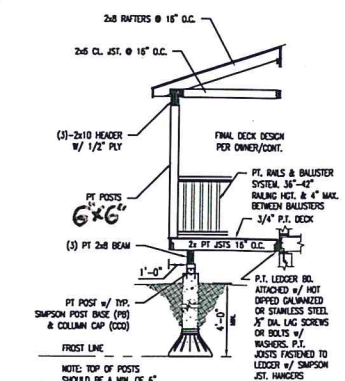

NOTE:
1. THE GROUND IMMEDIATELY ADJACENT TO THE FOUNDATION SHALL BE SLOPED AWAY FROM THE BUILDING AT A SLOPE OF 1/2\"/>

2. SUBSTITUTE FLR JOSTS AND STUD WALL SIZES WITH PLAN CALL OUT

CONC. SNOTUBES AT COVERED PORCH
N.T.S.

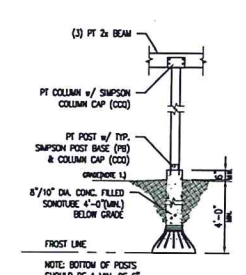

NOTE:
1. THE GROUND IMMEDIATELY ADJACENT TO THE FOUNDATION SHALL BE SLOPED AWAY FROM THE BUILDING AT A SLOPE OF 1/2\"/>

2. SUBSTITUTE FLR JOSTS AND STUD WALL SIZES WITH PLAN CALL OUT

CONC. SNOTUBES AT DECKING
N.T.S.

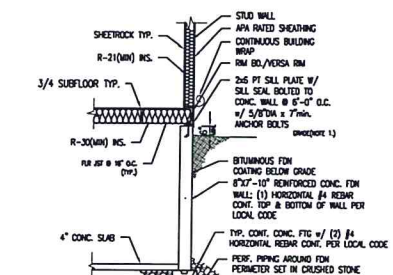

NOTE:
1. THE GROUND IMMEDIATELY ADJACENT TO THE FOUNDATION SHALL BE SLOPED AWAY FROM THE BUILDING AT A SLOPE OF 1/2\"/>

2. SUBSTITUTE FLR JOSTS AND STUD WALL SIZES WITH PLAN CALL OUT

TYPICAL INS. BETWEEN FDN & 1st FLR
N.T.S.

CONSTRUCTION NOTE:
CONTRACTOR IS TO VERIFY GRADE AND ALL DIMENSIONS IN FIELD BEFORE CONSTRUCTION. SECTION SHOWN MAY DIFFER FROM ACTUAL. FINISHED CONSTRUCTION. FINAL MATERIALS, WINDOW/DOOR LOCATIONS AND SIZES, TO BE DETERMINED PER OWNER/CONTR. SITE CONDITIONS, AND/OR LOCAL CODES.

Proposed Section Plans

DRAWINGS ARE PROVIDED BY SOUTHERN MAKE DRAWING & DESIGN AS A SERVICE TO THE ARCHITECT AND ARE INTENDED FOR INFORMATIONAL AND ILLUSTRATIVE PURPOSES ONLY. THESE DRAWINGS ARE NOT TO BE USED FOR CONSTRUCTION OR AS A BASIS FOR CONSTRUCTION. THE ARCHITECT OR REGISTERED ARCHITECT ADVANTAGE & DESIGN SUGGESTS THAT HIS CUSTOMERS SEEK THE SERVICES OF A REGISTERED ARCHITECT TO OBTAIN TECHNICAL BLUE PRINTS. IF THE CUSTOMER OR REGISTERED ARCHITECT TO OBTAIN TECHNICAL BLUE PRINTS, THE ARCHITECT OR REGISTERED ARCHITECT SHALL BE RESPONSIBLE FOR CONSTRUCTION AND SOUTHERN MAKE DRAWING & DESIGN DISCLAIMS ANY RESPONSIBILITY IF THEY ARE SO USED.

Revisions:

NO.	DATE	DESCRIPTION

Date : 04/30/15
Scale : 1/4"=1'-0"
Drawn By: JTM
Project: CLD41615
Sheet Number: