

Proposed Section Plans

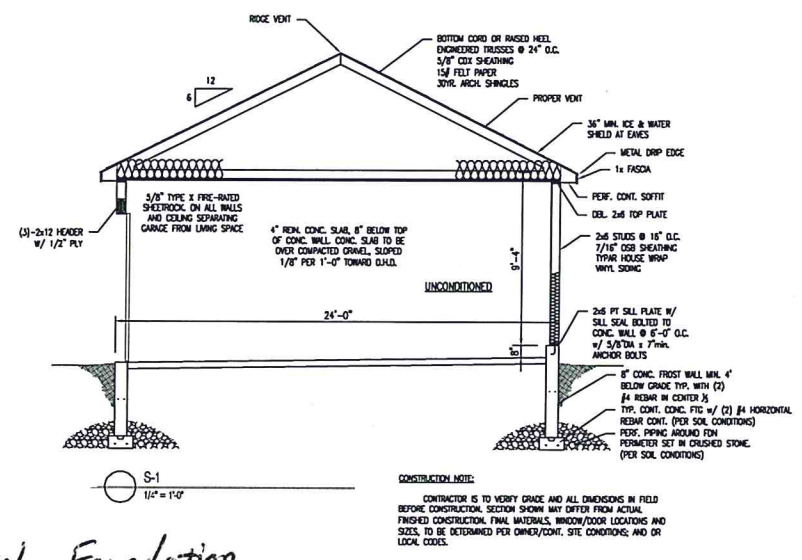

Typical Foundation size is 8' x 16'

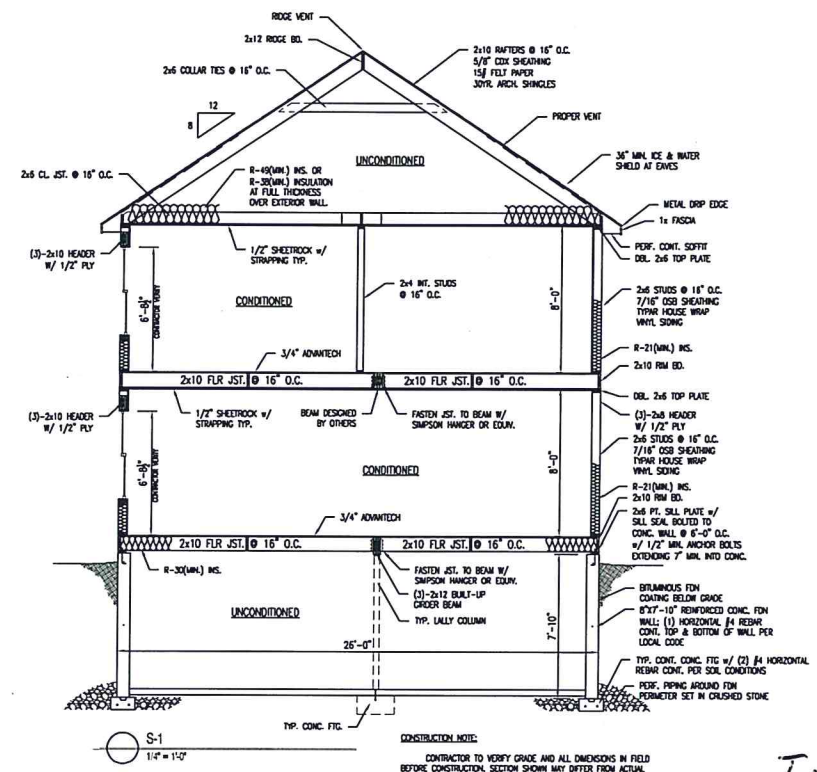
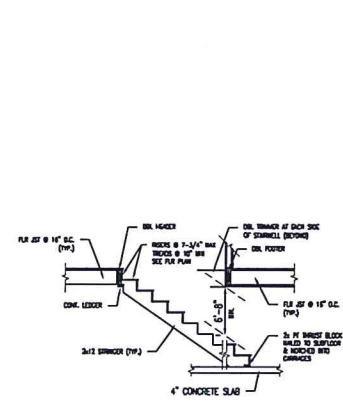

NOTES:  
 1. SUBSTITUTE RAFTER, CL JSTS & STUD WALL SIZES WITH PLAN CALL OUT

TYPICAL STAIR FRAMING  
 N.T.S.

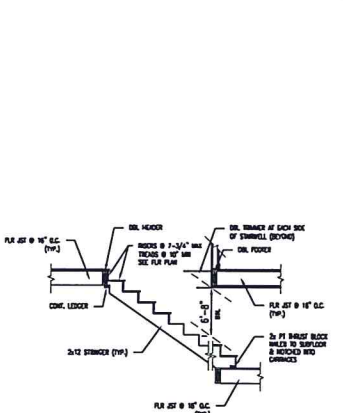

NOTES:  
 1. SUBSTITUTE RAFTER, CL JSTS & STUD WALL SIZES WITH PLAN CALL OUT

TYPICAL STAIR FRAMING  
 N.T.S.

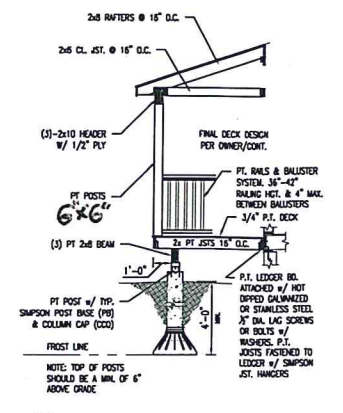

NOTE:  
 1. THE GROUND IMMEDIATELY ADJACENT TO THE FOUNDATION SHALL BE SLOPED AWAY FROM THE BUILDING AT A SLOPE OF 1/2\"/>
 2. SUBSTITUTE FLR JOSTS AND STUD WALL SIZES WITH PLAN CALL OUT

CONC. SNOTUBES AT COVERED PORCH  
 N.T.S.

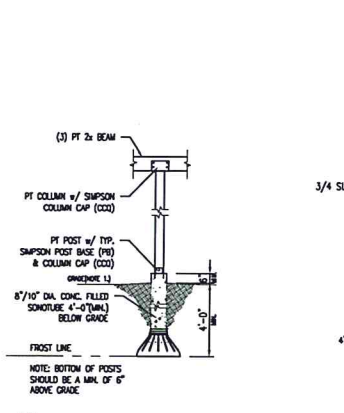

NOTE:  
 1. THE GROUND IMMEDIATELY ADJACENT TO THE FOUNDATION SHALL BE SLOPED AWAY FROM THE BUILDING AT A SLOPE OF 1/2\"/>
 2. SUBSTITUTE FLR JOSTS AND STUD WALL SIZES WITH PLAN CALL OUT

CONC. SNOTUBES AT DECKING  
 N.T.S.

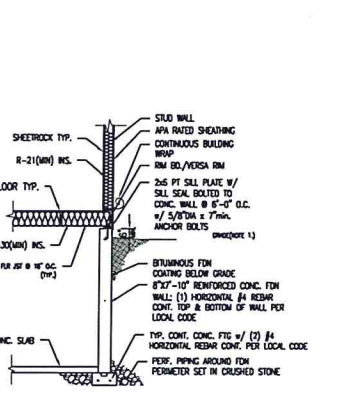

NOTE:  
 1. THE GROUND IMMEDIATELY ADJACENT TO THE FOUNDATION SHALL BE SLOPED AWAY FROM THE BUILDING AT A SLOPE OF 1/2\"/>
 2. SUBSTITUTE FLR JOSTS AND STUD WALL SIZES WITH PLAN CALL OUT

TYPICAL INS. BETWEEN FDN & 1st FLR  
 N.T.S.

DRAWINGS ARE PROVIDED BY SOUTHERN MANE DRAFTING & DESIGN AS A SERVICE TO HIS CUSTOMERS AND ARE INTENDED FOR INFORMATIONAL AND REFERENCE PURPOSES ONLY. THESE DRAWINGS ARE NOT TO BE USED FOR CONSTRUCTION OR FOR ANY OTHER PURPOSES WITHOUT THE WRITTEN PERMISSION OF SOUTHERN MANE DRAFTING & DESIGN. SOUTHERN MANE DRAFTING & DESIGN SHALL NOT BE RESPONSIBLE FOR ANY ERRORS OR OMISSIONS IN THESE DRAWINGS. THE USER OF THESE DRAWINGS SHALL BE RESPONSIBLE FOR VERIFYING ALL DIMENSIONS AND CONDITIONS IN THE FIELD BEFORE CONSTRUCTION. SOUTHERN MANE DRAFTING & DESIGN DISCLAIMS ANY LIABILITY FOR CONSTRUCTION AND SOUTHERN MANE DRAFTING & DESIGN DISCLAIMS ANY RESPONSIBILITY IF THEY ARE SO USED.

Revisions:

NO.	DATE	DESCRIPTION

Date : 04/30/15  
 Scale : 1/4"=1'-0"  
 Drawn By: JTM  
 Project: CLD41615  
 Sheet Number:  
 3 of 4