

DISPLAY THIS CARD ON PRINCIPAL FRONTAGE OF WORK



CITY OF PORTLAND BUILDING PERMIT

This is to certify that CONSTRUCTIONCORP KING

Located At 29 STEPPING STONE

Job ID: 2011-03-543-SF

CBL: 406 - - F - 056 - 001 - - - -

has permission to New 1,598 sf Single Family Home

provided that the person or persons, firm or corporation accepting this permit shall comply with all of the provisions of the Statues of Maine and of the Ordinances of the City of Portland regulating the construction, maintenance and use of the buildings and structures, and of the application on file in the department.

Notification of inspection and written permission procured before this building or part thereof is lathed or otherwise closed-in. 48 HOUR NOTICE IS REQUIRED.

A final inspection must be completed by owner before this building or part thereof is occupied. If a certificate of occupancy is required, it must be

04/14/2011

Fire Prevention Officer

Code Enforcement Officer / Plan Reviewer

THIS CARD MUST BE POSTED ON THE STREET SIDE OF THE PROPERTY.

PENALTY FOR REMOVING THIS CAR

SCANNED



Certificate of Occupancy

CITY OF PORTLAND, MAINE

Department of Planning and Urban Development
Building Inspections Division



Issued to: King Construction Corp

Date Issued: 8/25/2011

Location: 29 Stepping Stone Ln

CBL: 406 F056001

This is to certify that the building, premises, or part thereof, at the above location, built-altered-changed as to use under Building Permit No. 2011-03-543, has had a final inspection, has been found to conform substantially to the requirements of the Building Code and the Land Use Code of the City of Portland, and is hereby approved for occupancy or use, limited or otherwise, as indicated below.

PORTION OF BUILDING OR PREMISES

Entire

APPROVED OCCUPANCY

Single Family Home

Use Group R-3

Type 5B

IRC-2009

Limiting Conditions: NONE

Approved:

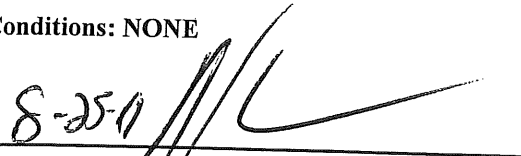
8-25-11 

Inspector

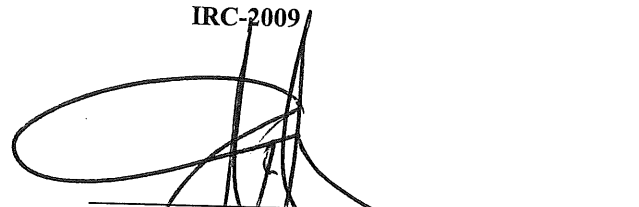

Inspections Division Director

Notice: This certificate identifies the legal use of the building or premises, and ought to be transferred from owner to owner upon the sale of the property.

City of Portland, Maine - Building or Use Permit Application

389 Congress Street, 04101 Tel: (207) 874-8703, FAX: (207) 8716

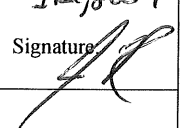
Job No: 2011-03-543-SF	Date Applied: 3/2/2011	CBL: 406 - - F - 056 - 001 - - - - -	
Location of Construction: 29 STEPPING STONE	Owner Name: KING CONSTRUCTION CORP	Owner Address: 198 SACO AVE OLD ORCHARD BEACH, ME 04064	Phone:
Business Name:	Contractor Name: Brackett, Dwight	Contractor Address: 84 Country LN PORTLAND ME04103	Phone: 756-0687
Lessee/Buyer's Name: Dwight Brackett	Phone:	Permit Type: BLDG - Building	Zone: R-3
Past Use: Vacant - Lot 6	Proposed Use: New single family home	Cost of Work: 110000.00	CEO District:
		Fire Dept: <input checked="" type="checkbox"/> Approved <input type="checkbox"/> Denied <input type="checkbox"/> N/A	Inspection: Use Group: R3 Type: SB IRC 3009
		Signature: CAPT. D. Sauter	Signature: 
Proposed Project Description: Stepping Stone Lane / Lot#6 - new single family home		Pedestrian Activities District (P.A.D.)	
Permit Taken By:	Zoning Approval		

<p>1. This permit application does not preclude the Applicant(s) from meeting applicable State and Federal Rules.</p> <p>2. Building Permits do not include plumbing, septic or electrical work.</p> <p>3. Building permits are void if work is not started within six (6) months of the date of issuance. False informatin may invalidate a building permit and stop all work.</p>	Special Zone or Reviews <input type="checkbox"/> Shoreland <i>N/A</i> <input type="checkbox"/> Wetlands <i>N/A</i> <input type="checkbox"/> Flood Zone <i>panel 7 - zone X</i> <input type="checkbox"/> Subdivision <input checked="" type="checkbox"/> Site Plan <i>Level I Minor Residential</i> <input type="checkbox"/> Maj <input type="checkbox"/> Min <input type="checkbox"/> MM Date: 3/15/11 <i>OK w/ conditions ABM</i>	Zoning Appeal <input type="checkbox"/> Variance <input type="checkbox"/> Miscellaneous <input type="checkbox"/> Conditional Use <input type="checkbox"/> Interpretation <input type="checkbox"/> Approved <input type="checkbox"/> Denied Date:	Historic Preservation <input type="checkbox"/> Not in Dist or Landmark <input type="checkbox"/> Does not Require Review <input type="checkbox"/> Requires Review <input type="checkbox"/> Approved <input type="checkbox"/> Approved w/Conditions <input type="checkbox"/> Denied Date:
	CERTIFICATION		

I hereby certify that I am the owner of record of the named property, or that the proposed work is authorized by the owner of record and that I have been authorized by the owner to make this application as his authorized agent and I agree to conform to all applicable laws of this jurisdiction. In addition, if a permit for work described in the application is issued, I certify that the code official's authorized representative shall have the authority to enter all areas covered by such permit at any reasonable hour to enforce the provision of the code(s) applicable to such permit.

SIGNATURE OF APPLICANT	ADDRESS	DATE	PHONE
RESPONSIBLE PERSON IN CHARGE OF WORK, TITLE		DATE	PHON

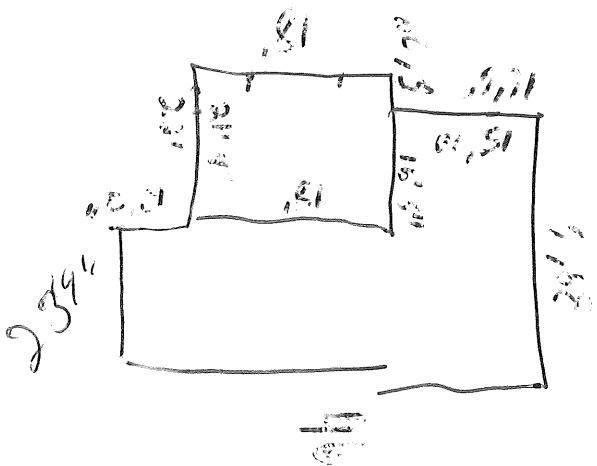

1/2" Gypsum 6'0.c.
 Still need survey before
 And Insulation insp

Water and sewer
 Sleaved in
 wall



6-2-11

Missing Riser Vent
 Non plates

Loose wires
 Need to remove wires from scuttle openings
 Missing J-Hangers.

Wm

Memorandum
Department of Planning and Urban Development
Planning Division



TO: Inspections Department

FROM: Philip DiPierro, Development Review Coordinator

DATE: August 25, 2011

RE: C. of O. for # 29 Stepping Stone Lane-Lot #6,
(Id#2011-03-543-SF) (CBL 406 F 056001)

After visiting the site, I have the following comments:

Site work complete:

At this time, **I recommend issuing a Permanent Certificate of Occupancy.**

Cc: Tammy Munson, Inspection Services Manager
File: Barbara Barhydt, Development Review Services Manager
File: 1 Solution

BUILDING PERMIT INSPECTION PROCEDURES

Please call 874-8703 or 874-8693 (ONLY)

or email: buildinginspections@portlandmaine.gov

With the issuance of this permit, the owner, builder or their designee is required to provide adequate notice to the city of Portland Inspections Services for the following inspections. Appointments must be requested 48 to 72 hours in advance of the required inspection. The inspection date will need to be confirmed by this office.

- **Please read the conditions of approval that is attached to this permit!! Contact this office if you have any questions.**
 - **Permits expire in 6 months. If the project is not started or ceases for 6 months.**
 - **If the inspection requirements are not followed as stated below additional fees may be incurred due to the issuance of a "Stop Work Order" and subsequent release to continue.**
1. Footings/ Setbacks
 2. Backfill
 3. Close-In (Electrical, Plumbing, Framing)
 4. Final Inspection/ Certificate of Occupancy

The project cannot move to the next phase prior to the required inspection and approval to continue, REGARDLESS OF THE NOTICE OF CIRCUMSTANCES.

IF THE PERMIT REQUIRES A CERTIFICATE OF OCCUPANCY, IT MUST BE PAID FOR AND ISSUED TO THE OWNER OR DESIGNEE BEFORE THE SPACE MAY BE OCCUOPIED.

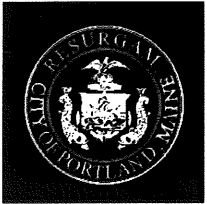

PORTLAND MAINE

Strengthening a Remarkable City, Building a Community for Life • www.portlandmaine.gov

Director of Planning and Urban Development
Penny St. Louis

Job ID: 2011-03-543-SF

Located At: 29 STEPPING STONE CBL: 406 - - F - 056 - 001 - - - -

Conditions of Approval:

Zoning

1. This permit is being approved on the basis of plans submitted. Any deviations shall require a separate approval before starting that work.
2. This property shall remain a single family dwelling. Any change of use shall require a separate permit application for review and approval.
3. As discussed during the review process, the property must be clearly identified prior to pouring concrete and compliance with the required setbacks must be established. Due to the proximity of the setbacks of the proposed structure, it may be required to be located by a surveyor.

DRC

1. The Development Review Coordinator reserves the right to require additional lot grading or other drainage improvements as necessary due to field conditions.
2. The applicant shall have a licensed surveyor install, prior to the issuance of any Certificate of Occupancy, permanent monumentation/pins identifying property corners.
3. A street opening permit(s) is required for your site. Please contact Carol Merritt at 874-8300, ext. 8822. (Only excavators licensed by the City of Portland are eligible.)
4. All damage to sidewalk, curb, street, or public utilities shall be repaired to City of Portland standards prior to issuance of a certificate of occupancy.
5. The Development Review Coordinator (874-8632) must be notified five (5) working days prior to date required for final site inspection. Please make allowances for completion of site plan requirements determined to be incomplete or defective during the inspection. This is essential as all site plan requirements must be completed and approved by the Development Review Coordinator prior to issuance of a Certificate of Occupancy. Please schedule any property closing with these requirements in mind.
6. Two (2) City of Portland approved species and size trees must be planted on your street frontage prior to issuance of a Certificate of Occupancy.
7. All Site work (final grading, landscaping, loam and seed) must be completed prior to issuance of a certificate of occupancy. Trees that are designated to be saved are to be protected during excavation and construction.
8. Erosion and Sedimentation control shall be established and inspected by the Development Review Coordinator prior to soil disturbance, and shall be done in accordance with Best Management Practices, Maine Department of Environmental Protection Technical and Design Standards and Guidelines. All Erosion and Sedimentation control measures must be inspected and maintained daily.

9. A sewer permit is required for your project. Please contact Carol Merritt at 874-8300, ext . 8822. The Wastewater and Drainage section of Public Services must be notified five (5) working days prior to sewer connection to schedule an inspector for your site.

Fire

1. New single family home will require a sprinkler system installed in compliance with NFPA 13D.
2. A separate non-fee sprinkler permit shall be required. A copy of the State Fire Marshal's sprinkler permit shall accompany the Fire Department permit. Capt. Gautreau

Building

1. Separate permits are required for any electrical, plumbing, sprinkler, fire alarm HVAC systems, heating appliances, commercial hood exhaust systems and fuel tanks. Separate plans may need to be submitted for approval as a part of this process.
2. R311.5.1 Attachment. Exterior landings, decks, balconies, stairs and similar facilities shall be positively anchored to the primary structure to resist both vertical and lateral forces or shall be designed to be self-supporting. Attachment shall not be accomplished by use of toenails or nails subject to withdrawal.
3. The door opening between the garage and residence shall be equipped with solid wood doors not less than 1 3/8" inches in thickness, solid or honeycomb core steel doors not less than 1 3/8 inches thick, or 20-minute fire-rated doors.
4. A photoelectric Carbon Monoxide (CO) detector shall be installed in each area within or giving access to bedrooms. That detection must be powered by the electrical service in the building and battery.
5. Hardwired photoelectric interconnected battery backup smoke detectors shall be installed in all bedrooms, protecting the bedrooms, and on every level.
6. Energy Efficiency (N1101.2.1) "R-Factors of Walls, Floors, Ceilings, Building Envelope must be submitted to this Office prior to close-in or backfill.
7. Glass glazing required adjacent to stairways when exposed surface of the glass is less than 60 inches above the nose of the tread.
8. Window sills in locations more than 72 inches from finished grade shall be a minimum of 24 inches above the finished floor of the room, unless a window fall prevention devices is installed in accordance with section R612.3.

<p>Pitch, Span, Spacing & Dimension (Table R802.5.1(1) - R 802.5.1(8)) Roof Rafter; Framing & Connections (Section R802.3 & R802.3.1)</p>	<p>8" Trusses @ 24" O.C. Roof: 5/8 w/ Penn Edges Cell: 7/16 & 1/2 Ext.</p>	<p>① Need specs 40 PSF</p>
<p>Sheathing; Floor, Wall and roof (Table R503.2.1.1(1))</p>	<p>(1) Hour Rated Ceiling w/ 5/8 Type x (1) Hour Rated Walls w/ 5/8 Type x</p>	<p>②</p>
<p>Fastener Schedule (Table R602.3(1) & (2)) Private Garage (Section R309) Living Space? (Above or beside)</p>	<p>" 3068 Rated" Shown</p>	<p>20 Min fire Door Required.</p>
<p>Fire separation (Section R309.2) Opening Protection (Section R309.1)</p>	<p>Egress Window Shown</p>	<p>Okay</p>
<p>Emergency Escape and Rescue Openings (Section R310)</p>	<p>30yr Architectural</p>	<p>Okay</p>
<p>Roof Covering (Chapter 9)</p>	<p>Master Bath 1st Floor Tjs Required</p>	<p>③</p>
<p>Safety Glazing (Section R308)</p>	<p>22x30" Required</p>	<p>④</p>
<p>Attic Access (Section R807)</p>		
<p>Chimney Clearances/Fire Blocking (Chap. 10)</p>	<p>③ 2x16</p>	<p>⑤</p>
<p>Header Schedule (Section 502.5(1) & (2)) Energy Efficiency (N1101.2.1) R-Factors of Walls, Floors, Ceilings, Building Envelope, U-Factor Fenestration</p>	<p>Ceiling R-49</p>	<p>⑥</p>

Type of Heating System		
Means of Egress (Sec R311 & R312)		
Basement		
Number of Stairways		
Interior		
Exterior		
Treads and Risers (Section R311.5.3)	10" x 7 3/4"	
Width (Section R311.5.1)	3-10"	⑨
Headroom (Section R311.5.2)	6-8" Required	
Guardrails and Handrails (Section R312 & R311.5.6 – R311.5.6.3)	34-38" Resp.	
Smoke Detectors (Section R313) Location and type/Interconnected	CO & SPD Required	⑤
Dwelling Unit Separation (Section R317) and IBC – 2003 (Section 1207)		
Deck Construction (Section R502.2.1)		⑨

ONE AND TWO FAMILY	PLAN REVIEW	CHECKLIST
Soil type/Presumptive Load Value (Table R401.4.1)	Submitted Plan	Findings/Revisions/Dates
Component		
STRUCTURAL Footing Dimensions/Depth (Table R403.1 & R403.1(1), (Section R403.1 & R403.1.4.1)	8" x 16" w/ 2-#4 Rebar 4" slab	
Foundation Drainage, Fabric, Damp proofing (Section R405 & R406)	Drainage & Damp Proofing	11
Ventilation/Access (Section R408.1 & R408.3) Crawls Space ONLY	N/A	12
Anchor Bolts/Straps, spacing (Section R403.1.6)	5/8" DIA x 10' / 3'-0" O.C. 1'-0" - corners	Check
Lally Column Type (Section R407)	N/A	
Girder & Header Spans (Table R 502.5(2))	N/A	
Built-Up Wood Center Girder Dimension/Type	N/A	
Sill/Band Joist Type & Dimensions	2x6" PT w/ Sealer	Check
First Floor Joist Species Dimensions and Spacing (Table R502.3.1(1) & Table R502.3.1(2))	Vapor Barrier Req.	
Second Floor Joist Species Dimensions and Spacing (Table R502.3.1(1) & Table R502.3.1(2))	2x10" @ 16" O.C. 12-3 Max Trusses	Check
Attic or additional Floor Joist Species Dimensions and Spacing (Table R802.4(1) and R802.4(2))		1

Applicant: Dwight Brackett

Date: 3/15/11

Address: 29 Stepping Stone Lane (Lot 6)

C-B-L: 406-F-056
permit # 2011-03-543

CHECK-LIST AGAINST ZONING ORDINANCE

Date - New

Zone Location - R-3

Interior or corner lot -

Proposed Use/Work - build new single family - two story - 48' x 46' x - 1 car garage attached

Sewage Disposal - City

Lot Street Frontage - 50' min. - 50' scaled (ok)

Front Yard - 25' min. - 26' scaled (ok)

Rear Yard - 25' min. 26' scaled (ok)

Side Yard - 2 spaces - 14' min. - 20' scaled on right (ok)
- 15' scaled on left (ok)

Projections -

Width of Lot - 65' min. - 68' scaled (ok)

Height - 35' max. - 17' scaled (ok)

Lot Area - 6,500 sq ft min. - 8958 sq ft

12 x 24 = 288
18 x 45 = 810
16 x 44 = 704

1802 (ok)

Lot Coverage Impervious Surface - 35% = 3135.3 sq ft

Area per Family - 6,500 sq ft (ok)

Off-street Parking - 2 spaces required - one car garage (18' x 21) + one space 21' x 12' (ok)

Loading Bays - N/A

Site Plan - Level I Minor Residential

Shoreland Zoning/Stream Protection - N/A

Flood Plains - panel 7 - Zone X

CBL	OWNER	OWNER MAILING ADDRESS	PROPERTY LOCATION	UNITS
	CALDER PATRICK D	25 STEPPING STONE LN PORTLAND, ME 04103	25 STEPPING STONE LN	1
	INJAC TATJANA & IGOR INJAC JTS	11 HUNTINGTON AVE PORTLAND, ME 04104	22 STEPPING STONE LN	1
	KING CONSTRUCTION CORP	198 SACO AVE OLD ORCHARD BEACH, ME 04064	24 STEPPING STONE LN	0
	KING CONSTRUCTION CORP	198 SACO AVE OLD ORCHARD BEACH, ME 04064	29 STEPPING STONE LN	0
	LEIGHTON EUGENE H	197 RAY ST PORTLAND, ME 04103	197 RAY ST	1
	NGUYEN TUANH	19 STEPPING STONE LN PORTLAND, ME 04103	19 STEPPING STONE LN	1
	PEIGHTAL PATRICIA M	195 RAY ST PORTLAND, ME 04103	MARLBOROUGH RD	0
	PEIGHTAL PATRICIA M	195 RAY ST PORTLAND, ME 04103	195 RAY ST	1
	PIROZZI ELEANOR A TRUSTEE	519 BRIDGE ST APT 201 MANCHESTER, NH 03104	MARLBOROUGH RD	0
	POMPEO ROCCO JOSEPH	130 VERANDA ST PORTLAND, ME 04103	0 MARLBOROUGH RD	0
	POMPEO ROCCO JOSEPH	130 VERANDA ST PORTLAND, ME 04103	MARLBOROUGH RD	0
	REEVE WILLIAM & CAROL JTS	209 RAY ST PORTLAND, ME 04103	209 RAY ST	1
	ROTOLO ANTOINETTE T WID	203 RAY ST PORTLAND, ME 04103	203 RAY ST	1
	TUN U SHWE & AYE MIE MIE JTS	213 RAY ST PORTLAND, ME 04103	213 RAY ST	1

CBL	OWNER	OWNER MAILING ADDRESS	PROPERTY LOCATION	UNITS
-----	-------	-----------------------	-------------------	-------

Total Listed: 14

8

407 D022

406 F058

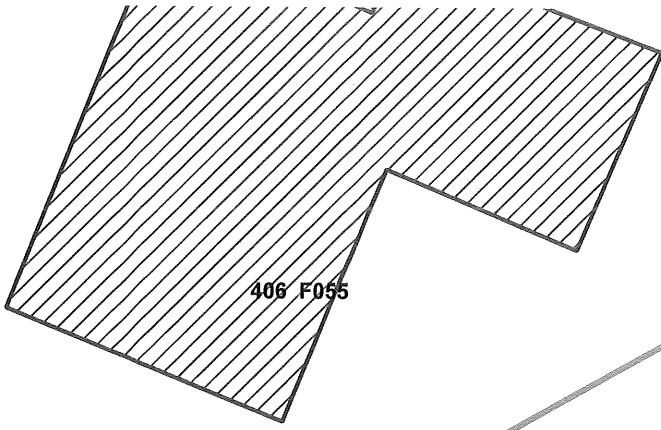

406 F055

STEPPING STONE LN

406 F057

406 F056

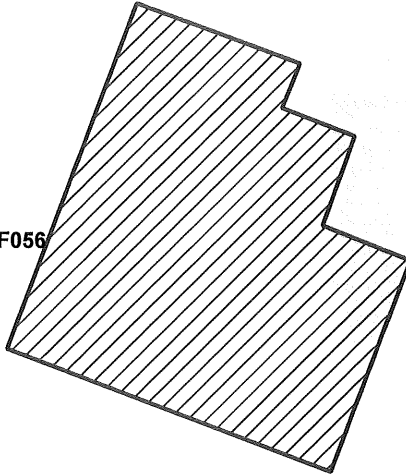

407 D015

407 D020

407 D014

407 D025

407 D013

407 D012

407 D011

407 D010

407 D009

407 D008

CD ✓ 66 entered 3/8/11 60

General Building Permit Application



If you or the property owner owes real estate or personal property taxes or user charges on any property within the City, payment arrangements must be made before permits of any kind are accepted.

#29

Location/Address of Construction: <u>LOT #6 STEPPING STONE LAKE</u>		
Total Square Footage of Proposed Structure/Area <u>1,598</u>	Square Footage of Lot <u>8958</u>	Number of Stories <u>2</u>
Tax Assessor's Chart, Block & Lot Chart# <u>406</u> Block# <u>F</u> Lot# <u>056</u>	Applicant *must be <u>(owner)</u> Lessee or Buyer* Name <u>DWIGHT BRACKETT</u> Address <u>84 COUNTRY LANE</u> City, State & Zip <u>PORTLAND ME 04103</u>	Telephone: <u>756-0687</u> <u>Call first</u>
Lessee/DBA (If Applicable)	Owner (if different from Applicant) Name Address City, State & Zip	Cost Of Work: \$ <u>110,000</u> C of O Fee: \$ _____ Total Fee: \$ _____
Current legal use (i.e. single family) <u>SINGLE FAMILY</u> Number of Residential Units <u>1</u> If vacant, what was the previous use? <u>VACANT LOT #6</u> Proposed Specific use: _____ Is property part of a subdivision? <u>YES</u> If yes, please name <u>AUTUMN GLEN SUB.</u> Project description: <u>3 BED ROOM RANCH</u>		
Contractor's name: <u>D.A. BRACKETT & CO INC</u> Address: <u>84 COUNTRY LANE</u> City, State & Zip <u>PORTLAND ME 04103</u> Telephone: <u>756-0687</u> Who should we contact when the permit is ready: <u>DWIGHT BRACKETT</u> Telephone: <u>756-0687</u> Mailing address: <u>84 COUNTRY LANE PORTLAND ME 04103</u>		

Bldg Fee 1120.00
SITE 300.00
CofO 75.00
Admin 100.00
Total 1,595.00

RECEIVED

Please submit all of the information outlined on the applicable Checklist. Failure to do so will result in the automatic denial of your permit.

MAR -2 2011

In order to be sure the City fully understands the full scope of the project, the Planning and Development Department may request additional information prior to the issuance of a permit. For further information or to download this form and other applications visit the Inspections Division on-line at www.portlandmaine.gov, or stop by the Inspections Division office, room 315 City Hall or call 874-8703.

I hereby certify that I am the Owner of record of the named property, or that the owner of record authorizes the proposed work and that I have been authorized by the owner to make this application as his/her authorized agent. I agree to conform to all applicable laws of this jurisdiction. In addition, if a permit for work described in this application is issued, I certify that the Code Official's authorized representative shall have the authority to enter all areas covered by this permit at any reasonable hour to enforce the provisions of the codes applicable to this permit.

Signature: Dwight Brackett Date: 2/28/11

This is not a permit; you may not commence ANY work until the permit is issued

<p>Pitch, Span, Spacing & Dimension (Table R802.5.1(1) - R 802.5.1(8)) Roof Rafter; Framing & Connections (Section R802.3 & R802.3.1)</p>	<p>8¹² Trusses @ 24" O.C. Roof: 5/8" w/ Panel Edges Walls: 7/16" @ 1/2 End.</p>	<p>① Need Specs @ 10 PSF</p>
<p>Sheathing; Floor, Wall and roof (Table R503.2.1.1(1))</p>		<p>②</p>
<p>Fastener Schedule (Table R602.3(1) & (2)) Private Garage (Section R309) Living Space? (Above or beside)</p>	<p>(1) Hair Rotted Ceilings w/ 5/8 Type X (1) Hair Rotted Walls w/ 5/8 Type X</p>	
<p>Fire separation (Section R309.2) Opening Protection (Section R309.1)</p>	<p>"3068 Rotted" Skown</p>	
<p>Emergency Escape and Rescue Openings (Section R310)</p>	<p>Egress windows skown</p>	<p>Okay</p>
<p>Roof Covering (Chapter 9)</p>	<p>30 yr Architectural</p>	<p>Okay</p>
<p>Safety Glazing (Section R308)</p>		<p>③</p>
<p>Attic Access (Section R807)</p>		<p>④</p>
<p>Chimney Clearances/Fire Blocking (Chap. 10)</p>		
<p>Header Schedule (Section 502.5(1) & (2))</p>		<p>⑤</p>
<p>Energy Efficiency (N1101.2.1) R-Factors of Walls, Floors, Ceilings, Building Envelope, U-Factor Fenestration</p>	<p>Ceiling R-49</p>	<p>⑥</p>

ONE AND TWO FAMILY	PLAN REVIEW	CHECKLIST
Soil type/Presumptive Load Value (Table R401.4.1)	Submitted Plan	Findings/Revisions/Dates
Component		
STRUCTURAL Footings Dimensions/Depth (Table R403.1 & R403.1(1)), (Section R403.1 & R403.1.4.1)	8" x 16" w/ 2 - #4 Rebar 4" Slab	
Foundation Drainage, Fabric, Damp proofing (Section R405 & R406)	Drenege	11
Ventilation/Access (Section R408.1 & R408.3) Crawls Space ONLY		10
Anchor Bolts/Straps, spacing (Section R403.1.6)	1/8" DIA x 1/2" 3:00 C 1:0 - Corners	Okay
Lally Column Type (Section R407)		
Girder & Header Spans (Table R 502.5(2))		
Built-Up Wood Center Girder Dimension/Type		
Sill/Band Joist Type & Dimensions	2x6" PT w/ Sealer	Okay
First Floor Joist Species Dimensions and Spacing (Table R502.3.1(1) & Table R502.3.1(2))	N/A Vapor Barrier?	
Second Floor Joist Species Dimensions and Spacing (Table R502.3.1(1) & Table R502.3.1(2))	Trusses	1
Attic or additional Floor Joist Species Dimensions and Spacing (Table R802.4(1) and R802.4(2))	Trusses	1

Type of Heating System		
Means of Egress (Sec R311 & R312)		7
Basement		
Number of Stairways		
Interior		
Exterior		
Treads and Risers (Section R311.5.3)	10"	
Width (Section R311.5.1)	3-10"	
Headroom (Section R311.5.2)		
Guardrails and Handrails (Section R312 & R311.5.6 – R311.5.6.3)		
Smoke Detectors (Section R313) Location and type/Interconnected		8
Dwelling Unit Separation (Section R317) and IBC – 2003 (Section 1207)		
Deck Construction (Section R502.2.1)		9

DEVELOPMENT REVIEW FEES:

Check all reviews that apply. Payment may be made in cash or check to the City of Portland.

<p>Level I Minor Residential Site Plan</p> <p>___ Application Fee (\$300.00 flat fee)</p> <p>The City invoices separately for the following:</p> <ul style="list-style-type: none"> • Notices (\$.75 each) 	<p>Fees Paid (office use)</p> <p>___</p>
<p>Inspection Fee: Inspection fee due after approval (for site plan inspection by the Planning Division)</p>	<p>\$100 (flat fee)</p>
<p>Performance Guarantee</p>	<p>Exempt except for those projects that complete construction in the winter and the site work is incomplete.</p>
<p>Building Permit Fee</p>	<p>\$30 for the first \$1,000 construction cost, \$10 per additional \$1,000 cost.</p>

Application Check List:

As of December 1, 2010, all site plans and written application materials must be uploaded to a website for review. At the time of application, instructions for uploading the plans will be provided to the applicant. One paper set of the plans, written materials and application fee must be submitted to the Planning Division Office to start the review process.

Inspections

Refer to the application checklist for a detailed list of submittal requirements.

Portland's development review process and requirements are outlined in the Land Use Code (Chapter 14), which includes the Subdivision Ordinance (Section 14-491) and the Site Plan Ordinance (Section 14-521). Portland's Land Use Code is on the City's web site: www.portlandmaine.gov Copies of the ordinances may be purchased through the Planning Division. All of the information on the checklist must be submitted for review. The applicant must check off the items contained in the application package to ensure the application is complete.

Property Taxes:

If you or the property owner owes real estate or personal property taxes or user charges on any property within the City, payment arrangements must be made before a permit of any kind is accepted.

Separate Permits:

Separate permits are required for internal and external plumbing, HVAC, and electrical installations.

I hereby certify that I am the Owner of record of the named property, or that the owner of record authorizes the proposed work and that I have been authorized by the owner to make this application as his/her authorized agent. I agree to conform to all applicable laws of this jurisdiction. In addition, if a permit for work described in this application is issued, I certify that the Planning Authority and Code Enforcement's authorized representative shall have the authority to enter all areas covered by this permit at any reasonable hour to enforce the provisions of the codes applicable to this permit.

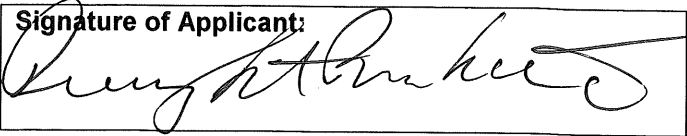
<p>Signature of Applicant:</p> 	<p>Date:</p> <p>2/28/11</p>
---	------------------------------------

This is not a permit; you may not commence any work until the permit is issued.

General Submittal Requirements – Level I Minor Residential

Applicant Checklist	Planner Checklist (internal)	Number of Copies	Submittal Requirement
<input checked="" type="checkbox"/>	<input checked="" type="checkbox"/>	3 (1 paper copy as of Dec. 1)	Completed application form and check list.
<input checked="" type="checkbox"/>	<input type="checkbox"/>	1	Application fees.
<input checked="" type="checkbox"/>	<input checked="" type="checkbox"/>	3 (1 paper copy as of Dec. 1)	Evidence of right, title and interest.
<input checked="" type="checkbox"/>	<input type="checkbox"/> H/A	3 (1 paper copy as of Dec. 1)	Copies of required state and/or federal permits.
<input checked="" type="checkbox"/>	<input type="checkbox"/>	3 (1 paper copy as of Dec. 1)	Written Description of existing and proposed easements or other burdens.
<input checked="" type="checkbox"/>	<input type="checkbox"/> H/A	3 (1 paper copy as of Dec. 1)	Written requests for waivers from individual site plan and/or technical standards.
<input checked="" type="checkbox"/>	<input type="checkbox"/>	3 (1 paper copy as of Dec. 1)	Evidence of financial and technical capacity.
<input checked="" type="checkbox"/>	<input checked="" type="checkbox"/> OK. submit	3 (1 paper copy as of Dec. 1)	Written summary of fire safety (referencing NFPA fire code and Section 3 of the City of Portland Technical Manual). Refer to Fire Department Checklist on page 6 of this application.

Site Plans and Boundary Survey Requirements – Level I Minor Residential

Applicant Checklist	Planner Checklist (internal)	Number of Copies	Submittal Requirement
<input checked="" type="checkbox"/>	<input type="checkbox"/>	3 (1 paper copy as of Dec. 1)	Boundary survey meeting the requirements of section 13 of the City of Portland Technical Manual with the site plan information listed below shown on the plan, including a north arrow and a scale greater than or equal to 1"=20'. (Photocopies of the plat or hand drawn building footprints will not be accepted.)
<input checked="" type="checkbox"/>	<input type="checkbox"/>		▪ Zoning district, setbacks and dimensional requirements. Show zone lines and overlay zones that apply to the property, including Shoreland Zone &/or Stream Protection Zone.
<input checked="" type="checkbox"/>	<input type="checkbox"/>		▪ Existing and proposed structures (including location of proposed piers, docks or wharves if in Shoreland Zone).
<input checked="" type="checkbox"/>	<input type="checkbox"/>		▪ Location and dimension of existing and proposed paved areas.
<input checked="" type="checkbox"/>	<input type="checkbox"/>		▪ Proposed ground floor area of building.
<input checked="" type="checkbox"/>	<input type="checkbox"/>		▪ Finish floor elevation (FEE) or sill elevation.
<input checked="" type="checkbox"/>	<input type="checkbox"/>		▪ Exterior building elevations (show all 4 sides).
<input checked="" type="checkbox"/>	<input type="checkbox"/>		▪ Existing and proposed utilities (or septic system, where applicable)
<input checked="" type="checkbox"/>	<input type="checkbox"/>		▪ Existing and proposed grading and contours.
<input checked="" type="checkbox"/>	<input type="checkbox"/>		▪ Proposed stormwater management and erosion controls.
<input checked="" type="checkbox"/>	<input type="checkbox"/>		▪ Total area and limits of proposed land disturbance.

<input checked="" type="checkbox"/>	<input type="checkbox"/>	▪ Proposed protections to or alterations of watercourses.
<input checked="" type="checkbox"/>	<input type="checkbox"/>	▪ Proposed wetland protections or impacts.
<input checked="" type="checkbox"/>	<input type="checkbox"/>	▪ Existing vegetation to be preserved and proposed site landscaping and street trees (2 trees per unit for a single or two-family house).
<input checked="" type="checkbox"/>	<input type="checkbox"/>	▪ Existing and proposed curb and sidewalk, except for a single family home.
<input checked="" type="checkbox"/>	<input type="checkbox"/>	▪ Existing and proposed easements or public or private rights of way.
<input checked="" type="checkbox"/>	<input type="checkbox"/>	▪ Show foundation/perimeter drain and outlet.
<input checked="" type="checkbox"/>	<input type="checkbox"/>	▪ Additional requirements may apply for lots on unimproved streets.
<input checked="" type="checkbox"/>	<input type="checkbox"/>	3 (1 paper copy as of Dec. 1)
		Three sets of the reduced boundary survey/site plan is required if original is larger than 11'x17'

Building Permit Submittal Requirements –Level I: Minor Residential Development			
Applicant Checklist	Planner Checklist (internal)	Number of Copies	Submittal Requirement
		1	One (1) complete set of construction drawings must include:
<input checked="" type="checkbox"/>	<input type="checkbox"/>		▪ Cross section with framing details
<input checked="" type="checkbox"/>	<input type="checkbox"/>		▪ Floor plans and elevations to scale
<input checked="" type="checkbox"/>	<input type="checkbox"/>		▪ Stair details including dimensions of : rise/run, head room, guards/handrails, baluster space
<input checked="" type="checkbox"/>	<input type="checkbox"/>		▪ Window and door schedules
<input checked="" type="checkbox"/>	<input type="checkbox"/>		▪ Foundation plans w/required drainage and damp proofing , if applicable
<input checked="" type="checkbox"/>	<input type="checkbox"/>		▪ Detail egress requirements and fire separation, if applicable
<input checked="" type="checkbox"/>	<input type="checkbox"/>		▪ Insulation R-factors of walls, ceilings & floors & U-factors of windows per the IECC 2003
<input checked="" type="checkbox"/>	<input type="checkbox"/>		▪ Deck construction including: pier layout, framing, fastenings, guards, stair dimensions
<input checked="" type="checkbox"/>	<input type="checkbox"/>		▪ As of September 16, 2010 all new construction of one and two family homes are required to be sprinkled in compliance with NFPA 13D. This is required by City Code. (NFPA 101 2009 ed.)
<input type="checkbox"/>	<input type="checkbox"/>		▪ Reduced plans or electronic files in pdf format are also required if original plans are larger than 11X17"

Reminder: Separate permits are required for internal and external plumbing, HVAC, and electrical installations. Please submit all of the information outlined in this application checklist. If the application is incomplete, the application may be refused. The Planning and Urban Development Department may request additional information prior to the issuance of a permit.

Site Plan Standards for Review of Level I: Minor Residential

Level I: Minor Residential site plan applications are subject to the following site plan standards*, as contained in section 14-526 of Article V, Site Plan:

- 14-526 (a) **Transportation Standards:** 2.a.(i) and (ii);
2.c (if the site plan is a two-family or multi-family building);
4.a.(i) and (iv)
- 14-526 (b) **Environmental Quality Standards:** 1
2.a.
2.b.(iii)
3.a., c. and d. and e.
- 14-526 (c) **Public Infrastructure and Community Safety Standards:** 1. and 3.a through e.
- 14-526 (d) **Site Design Standards:** 5. and 9.

**Except as provided in Article III of the City Code, or to conditions imposed under Section 14-526(e) only, or to those submission requirements set forth in section 14-527 as relate solely thereto.*



**PORTLAND FIRE DEPARTMENT
SITE REVIEW
FIRE DEPARTMENT CHECKLIST**



A separate drawing[s] shall be provided to the Portland Fire Department for all site plan reviews.

1. Name, address, telephone number of applicant. *DWIGHT BRACKETT 84 COUNTRY LANE PORTLAND ME*
2. Name address, telephone number of architect *DEBRA PID 7560687*
3. Proposed uses of any structures [NFPA and IBC classification]
4. Square footage of all structures [total and per story] *FIRST FLOOR 1300 SQ FT SECOND 300 SQ FT*
5. Elevation of all structures *16 FEET*
6. Proposed fire protection of all structures *YES*
 - **As of September 16, 2010 all new construction of one and two family homes are required to be sprinkled in compliance with NFPA 13D. This is required by City Code. (NFPA 101 2009 ed.)**
7. Hydrant locations *100 FEET*

PURCHASE AND SALE AGREEMENT - LAND ONLY

February 11, 2011 Offer Date

2/21/11 Effective Date (Leave blank or check in Paragraph 20 of the Agreement)

1. PARTIES: This Agreement is made between B.J. Braddock & Co. ("Buyer") and King Construction Corp. ("Seller")

2. DESCRIPTION: Subject to the terms and conditions hereinafter set forth, Seller agrees to sell and Buyer agrees to buy () all () part of () part of (see part 20 for expiration) the property situated in municipality of Portland County of Cumberland, State of Maine, located at 28 Swampscott Street, Apt 6 and described in detail(s) recorded in said County's Registry of Deeds Book(s) 22058 Page(s) 002

3. PURCHASE PRICE: For such Deed and conveyance Buyer agrees to pay the total purchase price of \$ 65,000.00. Buyer has delivered or will deliver to the Agency within days of the Offer Date a deposit of earnest money in the amount of \$ 1,000.00. If said deposit is to be delivered after the submission of this offer and is not delivered by the above deadline, this offer shall be void and any attempted acceptance of this offer in reliance on the deposit being delivered will not result in a binding contract. Buyer agrees that an additional deposit of earnest money in the amount of \$ 2,500.00 will be delivered February 27, 2011. Failure by Buyer to deliver this additional deposit in compliance with the above terms shall constitute a default under this Agreement. The remainder of the purchase price shall be paid by wire, certified, cashier's or trust account check upon delivery of the Deed.

This Purchase and Sale Agreement is subject to the following conditions:

4. EARNEST MONEY/ACCEPTANCE: King Real Estate ("Agency") shall hold said earnest money and not as escrow agent until closing; this offer shall be valid until February 20, 2011 (date) 5:00 AM PM; and, in the event of non-acceptance, this earnest money shall be returned promptly to Buyer. In the event that the Agency is made a party to any lawsuit by virtue of acting as escrow agent, Agency shall be entitled to recover reasonable attorney's fees and costs which shall be assessed as court costs in favor of the prevailing party.

5. TITLE AND CLOSING: A deed conveying good and marketable title in accordance with the Standards of Title adopted by the Maine Bar Association shall be delivered to Buyer and this transaction shall be closed and Buyer shall pay the balance due and execute all necessary papers on March 31, 2011 (closing date) or before, if agreed in writing by both parties. If Seller is unable to convey in accordance with the provisions of this paragraph, then Seller shall have a reasonable time period, not to exceed 30 calendar days, from the time Seller is notified of the defect, unless otherwise agreed to in writing by both Buyer and Seller, to remedy the title. Seller hereby agrees to make a good-faith effort to cure any title defect during such period. If, at the later of the closing date set forth above or the expiration of such reasonable time period, Seller is unable to remedy the title, Buyer may close and accept the deed with the title defect or this Agreement shall become null and void in which case the parties shall be relieved of any further obligations hereunder and any earnest money shall be returned to the Buyer.

6. DEED: The property shall be conveyed by a Warranty deed, and shall be free and clear of all encumbrances except covenants, conditions, easements and restrictions of record which do not materially and adversely affect the continued current use of the property.

7. POSSESSION: Possession of premises shall be given to Buyer immediately at closing unless otherwise agreed in writing.

8. RISK OF LOSS: Until the closing, the risk of loss or damage to said premises by fire or otherwise, is assumed by Seller. Buyer shall have the right to view the property within 24 hours prior to closing for the purpose of determining that the premises are in substantially the same condition as on the date of this Agreement.

9. PROVISIONS: The following items, where applicable, shall be prorated as of the date of closing: rent, association fees, (other) N/A. Real estate taxes shall be prorated as of the date of closing (based on municipality's fiscal year). Seller is responsible for any unpaid taxes for prior years. If the amount of said taxes is not known at the time of closing, they shall be apportioned on the basis of the taxes assessed for the preceding year with a reapportionment as soon as the new tax rate and valuation can be ascertained, which latter provision shall survive closing. Buyer and Seller will each pay their transfer tax as required by State of Maine.

January 2011 Page 1 of 4 - BJS1.0 Buyer's Initials: [Signature] Seller's Initial: [Signature]

King Real Estate LLC, 5600 Avenue of the Orchard, Portland, ME 04106 Fax: (207) 634-7622 Danielle Lane Tripple Branch

20. **CONFIDENTIALITY:** Buyer and Seller authorize the disclosure of the information herein to the real estate licensee, attorneys, lenders, appraisers, inspectors, investigators and others involved in the transaction necessary for the purpose of closing this transaction. Buyer and Seller authorize the lender and/or closing agent preparing the entire closing statement to refer to a copy of the closing statement to the parties and their licensees prior to and after the closing.

21. **OTHER CONDITIONS:** C&C transformer to site and Buyer to provide underground lanes to house lot for service at its cost.

22. **GENERAL PROVISIONS:**

- a. A copy of this Agreement is to be received by all parties and by signature, receipt of a copy is hereby acknowledged. If not fully understood, contact an attorney. This is a Maine contract and shall be construed according to the laws of Maine.
- b. Seller acknowledges that State of Maine law requires buyers of property owned by non-resident sellers to withhold a prepayment of capital gain tax unless a waiver has been obtained by Seller from the State of Maine Revenue Services.
- c. Buyer and Seller acknowledge that, under Maine law payment of property taxes is the legal responsibility of the person who owns the property on April 1, over. If the property is sold before payment is due, if any part of the taxes is not paid when due, the lien will be filed in the name of the owner as of April 1 which could have a negative impact on their credit rating. Buyer and Seller shall agree at closing on their respective obligations regarding actual payment of taxes after closing. Buyer and Seller should make sure they understand their obligations prior to a closing and what may happen if taxes are not paid at closing.
- d. Buyer acknowledges that Maine law requires continuing interest in the property and any back up offers to be communicated by the listing agent to the Seller.

24. **ADDENDA:** Yes Explain Plans and copy of subdivision approval No

Buyer's Mailing address is 64 Country Lane, Portland, ME 04103

[Signature] 8/18/11
 BUYER _____ DATE _____ BUYER _____ DATE _____
 D.J. Brackett & Co.

Seller accepts the offer and agrees to deliver the above-described property at the price and upon the terms and conditions set forth and agrees to pay agency's commission for services as specified in the listing agreement.

Seller's Mailing address is 198 Scar Avenue, Old Orchard Beach, ME 04064

[Signature]
 SELLER King Construction, Corp _____ DATE _____ SELLER _____ DATE _____

COUNTER-OFFER

Seller agrees to sell on the terms and conditions as detailed herein with the following changes and/or conditions:

The parties acknowledge that until signed by Buyer, Seller's signature constitutes only an offer to sell on the above terms and the offer will expire unless accepted by Buyer's signature with communication of such signature to Seller by (date) _____ (time) _____ AM _____ PM.

SELLER _____ DATE _____ SELLER _____ DATE _____

The Buyer hereby accepts the counter offer set forth above.

BUYER _____ DATE _____ BUYER _____ DATE _____

EXTENSION:

The time for the performance of this Agreement is extended until _____ DATE _____

SELLER _____ DATE _____ SELLER _____ DATE _____

BUYER _____ DATE _____ BUYER _____ DATE _____



Maine Association of REALTORS/Copyright © 2011
 All Rights Reserved. Revised January 2011



11. FINANCING: This Agreement is is not subject to Financing. If subject to Financing:
- This Agreement is subject to Buyer obtaining a _____ loan of _____ of the purchase price, at an interest rate not to exceed _____, and amortized over a period of _____ years. Buyer is under a good faith obligation to seek and obtain financing on these terms.
 - Buyer to provide Seller with letter from lender showing that Buyer has made application for loan specified in (a) and subject to verification of information, is qualified for the loan requested within _____ days from the Effective Date of the Agreement. If Buyer fails to provide Seller with such letter within said time period, Seller may terminate this Agreement and the earnest money shall be returned to Buyer.
 - Buyer hereby authorizes, instructs and directs its lender to communicate the status of the Buyer's loan application to Seller, Seller's licensee or Buyer's licensee.
 - After (b) is met, Buyer is obligated to notify Seller in writing if a lender notifies Buyer that it is unable or unwilling to provide said financing. Any failure by Buyer to notify Seller within two days of receipt by Buyer of such notice from a lender shall be a default under this Agreement.
 - Buyer agrees to pay no more than _____ points, Seller agrees to pay up to \$ _____ toward Buyer's pre-pays, points and/or closing costs.
 - Buyer's ability to obtain financing is is not subject to the sale of another property. See addendum Yes No .
 - Buyer may choose to pay cash instead of obtaining financing. If so, Buyer shall notify Seller in writing including providing proof of funds and the Agreement shall no longer be subject to financing, and Seller's right to terminate pursuant to the provisions of this paragraph shall be void.

12. BROKERAGE DISCLOSURE: Buyer and Seller acknowledge they have been advised of the following relationships:

Danielle Lane (00555E) of King Royal Re/ate (147C)
 Licensee MLS ID Agency MLS ID

is a Seller Agent Buyer Agent Disc Dual Agent Transaction Broker

Elizabeth Dubois (00552C) of Re/Max By the Bay (1150)
 Licensee MLS ID Agency MLS ID

is a Seller Agent Buyer Agent Disc Dual Agent Transaction Broker

If this transaction involves Disclosed Dual Agency, the Buyer and Seller acknowledge the limited fiduciary duties of the agents and hereby consent to this arrangement. In addition, the Buyer and Seller acknowledge prior receipt and signing of a Disclosed Dual Agency Consent Agreement.

13. PROPERTY DISCLOSURE FORM: Buyer acknowledges receipt of Seller's Property Disclosure Form.

14. DEFAULT: In the event of default by the Buyer, Seller may employ all legal and equitable remedies, including without limitation, termination of this Agreement, and forfeiture by Buyer of the earnest money. In the event of a default by Seller, Buyer may employ all legal and equitable remedies, including without limitation, termination of this Agreement and return to Buyer of the earnest money. Agency acting as escrow agent has the option to require written release from both parties prior to disbursing the earnest money to either Buyer or Seller.

15. MEDIATION: Earnest money disputes subject to the jurisdiction of small claims court will be handled in that forum. For all other disputes or claims arising out of or relating to this Agreement on the property addressed in this Agreement shall be submitted to mediation in accordance with the Maine Residential Real Estate Mediation Rules. Buyer and Seller are bound to mediate in good faith and pay their respective mediation fees. If a party does not agree first to go to mediation, then that party will be liable for the other party's legal fees in any subsequent litigation regarding that same matter in which the party who refused to go to mediation loses in the subsequent litigation. This clause shall survive the closing of the transaction.

16. PRIOR STATEMENTS: Any representations, statements and agreements are not valid unless contained herein. This Agreement completely expresses the obligations of the parties.

17. HEIRS/ASSIGNS: This Agreement shall extend to and be obligatory upon heirs, personal representatives, successors, and assigns of the Seller and the assigns of the Buyer.

18. COUNTERPARTS: This Agreement may be signed on any number of identical counterparts, such as a faxed copy, with the same binding effect as if the signatures were on one instrument. Original, faxed or other electronically transmitted signatures are binding.

19. NOTICE: Any notice, communication, or document delivery requirements hereunder may be satisfied by providing the required notice, communication or documentation to the party or their licensee. Withdrawals of offers and counteroffers will be effective upon communication, verbally or in writing.

20. EFFECTIVE DATE: This Agreement is a binding contract when signed by both Buyer and Seller and when that fact has been communicated which shall be the Effective Date. Licensee is authorized to fill in the Effective Date on Page 1 hereof. Except as expressly set forth to the contrary, the use of the term "days" in this Agreement, including all addenda made a part hereof, shall mean business days defined as excluding Saturdays, Sundays and any observed Maine State/Federal holidays. Deadlines in this Agreement, including all addenda, expressed as "within x days" shall be counted from the Effective Date, unless another starting date is expressly set forth, beginning with the first day after the Effective Date, or such other established starting date, and ending at 5:00 p.m. Eastern Time on the last day counted. Unless expressly stated to the contrary, deadlines in this Agreement, including all addenda, expressed as a specific date shall end at 5:00 p.m. Eastern Time on such date.

10. DUE DILIGENCE: Buyer is encouraged to seek information from professionals regarding any specific issue or concern. Neither Seller nor Licensee makes any warranty regarding the condition, permitted use or value of Seller's real property. This Agreement is subject to the following contingencies, with results being satisfactory to Buyer:

CONTINGENCY	YES	NO	DAYS FOR COMPLETION	OBTAINED BY	TO BE PAID FOR BY
1. SURVEY Purpose: <u>Already given to Buyer</u>	<input checked="" type="checkbox"/>	<input type="checkbox"/>	_____	<u>Seller</u>	<u>Seller</u>
2. SOILS TEST Purpose: _____	<input type="checkbox"/>	<input type="checkbox"/>	_____	_____	_____
3. SEPTIC SYSTEM DESIGN Purpose: _____	<input type="checkbox"/>	<input type="checkbox"/>	_____	_____	_____
4. LOCAL PERMITS Purpose: <u>Building Permit - Apply within 5 Business days of effective date IF City of Portland does not grant permit within 30 Business Days, Seller will grant extension</u>	<input checked="" type="checkbox"/>	<input type="checkbox"/>	<u>30 BUSINESS</u>	<u>Buyer</u>	<u>Buyer</u>
5. HAZARDOUS WASTE REPORTS Purpose: _____	<input type="checkbox"/>	<input checked="" type="checkbox"/>	_____	_____	_____
6. UTILITIES Purpose: <u>Call transformer on site per As Built Plan on file at City & provided to Buyer</u>	<input checked="" type="checkbox"/>	<input type="checkbox"/>	_____	_____	_____
7. WATER Purpose: _____	<input type="checkbox"/>	<input checked="" type="checkbox"/>	_____	_____	_____
8. SUB-DIVISION APPROVAL Purpose: <u>Already given to Buyer</u>	<input checked="" type="checkbox"/>	<input type="checkbox"/>	_____	<u>Seller</u>	<u>Seller</u>
9. DEPLURC APPROVALS Purpose: _____	<input type="checkbox"/>	<input checked="" type="checkbox"/>	_____	_____	_____
10. ZONING VARIANCE Purpose: _____	<input type="checkbox"/>	<input checked="" type="checkbox"/>	_____	_____	_____
11. HABITAT REVIEW WATERFOWL Purpose: _____	<input type="checkbox"/>	<input type="checkbox"/>	_____	_____	_____
12. MDOT DRIVEWAY ENTRANCE PERMIT Purpose: _____	<input type="checkbox"/>	<input type="checkbox"/>	_____	_____	_____
13. DEED RESTRICTION Purpose: _____	<input type="checkbox"/>	<input checked="" type="checkbox"/>	_____	_____	_____
14. TAX EXEMPT STATUS Purpose: _____	<input type="checkbox"/>	<input checked="" type="checkbox"/>	_____	_____	_____
15. OTHER Purpose: _____	<input type="checkbox"/>	<input type="checkbox"/>	_____	_____	_____

Further specifications regarding any of the above: Clarification of drainage easement on plans of record at City of Portland; 2 back pins & monuments are set per EWM (Bill Thompson), front two pins were to be installed by Jim Seymour at Sebago Technics

Unless otherwise specified above, all of the above will be obtained and paid for by Buyer. If the result of any investigation or other condition specified herein is unsatisfactory to Buyer, Buyer will declare the Agreement null and void by notifying Seller in writing within the specified number of days, and any earnest money shall be returned to Buyer. If the result of any investigation or other condition specified herein is unsatisfactory to Buyer, and Buyer wishes to pursue remedies other than voiding the Agreement, Buyer must do so to full resolution within the time period set forth above; otherwise this contingency is waived. If Buyer does not notify Seller that an investigation is unsatisfactory within the time period set forth above, this contingency is waived by Buyer. In the absence of inspection(s) mentioned above, Buyer is relying completely upon Buyer's own opinion as to the condition of the property.

January 2011

Page 2 of 4 - PSN-10

Buyer(s) Initials: Dr's

Seller(s) Initials: CU

FAX



To: *Danghit*

Fax Number: *772-8629*

From: *Jon Ricux*

Fax Number:

Date: *04/13/11*

Regarding:

Total Number Of Pages Including Cover: *4*

Phone Number For Follow-Up: *874.8702*

Comments:

Missing info on every # 1-11

City Of Portland, Maine
Inspections Division Services
389 Congress St Room 315 Portland Me 04101-3509
Phone: (207) 874-8703 or (207)874-8693
Fax: (207) 874-8716
<http://www.portlandmaine.gov/>

CONFIRMATORY DEED

KNOW ALL MEN BY THESE PRESENTS,

THAT, NORTHEAST TRADING CORP., a Maine Corporation, of Freeport, in the County of Cumberland and State of Maine, in consideration of ONE DOLLAR (\$1.00) and other valuable consideration, paid by **KING CONSTRUCTION, CORP., a Maine Corporation, and /or its successors and assigns**, of Old Orchard Beach, County of York and State of Maine, whose mailing address is: 198 Saco Avenue, Old Orchard Beach, ME 04064, the receipt whereof it does hereby acknowledge, does hereby release all of its right, title, and interest in the following described property unto the said **KING CONSTRUCTION, CORP.** and/or its successors and assigns, to wit:

A certain lot or parcel of land situated on the westerly side of Beaugard Street in the City of Portland, County of Cumberland and State of Maine as shown on the Subdivision Plan/Recording Plat of Newcomb Glen Subdivision for Gunter-Paul, Inc. by Sebago Technics, Inc. dated February 15, 2002 and last revised August 4, 2003, bounded and described as follows:

Beginning at a 5/8" rebar to be set at the southeasterly corner of land now or formerly of Gregory McCormack and the southwesterly sideline of Beaugard Street;

Thence S 33°-51'-39" E, by and along the southwesterly sideline of Beaugard Street and the northeasterly sideline of Lot One, Patriot Lane, Lot Ten and Lot Eight, a distance of 394.23 feet to a point near a found loose 5/8" rebar with Cap Number 2063 at the easterly corner of said Lot Eight;

Thence S 57° 25' 55" W, by and along the northerly sideline of remaining land of Dean Cole as shown on said Plan, a distance of 1.06 feet to a point;

Thence S 61°-35'-11" W, by and along the northerly sideline of remaining land of Dean Cole as shown on said plan and land now or formerly of Rocco Joseph Pompeo as described in a deed recorded at Cumberland County Registry of Deeds in Book 2130, Page 386, and the southeasterly sideline of Lot Eight and Lot Seven, a distance of 329.68 feet to a point near a 1" iron pipe crimped and a 1/2" rebar 10 inches high at the most easterly corner of land now or formerly owned by Leighton as described in a deed recorded at Cumberland County Registry of Deeds in Book 6962, Page 349;

Thence N 70°-02'-31" W, by and along the northerly sideline of land of said Leighton and the southerly sideline of Lot Six and Lot Five as shown on said Plan, a distance of 157.26 feet to a 5/8" capped rebar to be set;

Thence N 19°-57'-29" E, by and along the westerly sideline of Lots Five, Four, Three, Two and a portion of Lot One as shown on said Plan, a distance of 430.00 feet to a 5/8" capped rebar to be set;

Thence N 70°-02'-31" W, by and along a portion of Lot One as shown on said Plan, a distance of 100.00 feet to a 5/8" capped rebar to be set near a 1/2" rebar 2 inches underground at the easterly sideline of Ray Street;

Thence N 19°-57'-29" E, by and along the easterly sideline of said Ray Street, a distance of 50.00 feet to a 5/8" capped rebar to be set at land of said McCormack;

Thence S 70°-02'-31" E, by and along land of said McCormack, a distance of 158.70 feet to the Point of Beginning.

Meaning and intending to describe the overall boundary of the area to be subdivided, containing approximately 2.79 acres.

Said parcel being subject to and benefited by all easements as shown on said Plan.

Said bearings are based on Grid north.

EXCEPTING AND RESERVING HEREFROM, Lot #4 as depicted on said Plan and being further described in a Partial Release dated August 24, 2004 and recorded in said Registry in Book 21769, Page 319 and Lot #5 as depicted on said Plan and being further described in a Partial Release dated June 24, 2004 and recorded in said Registry in Book 21475, Page 70.

Being a portion of the premises conveyed to Windemere Homes LLC, by warranty deed of Gunter-Paul, Inc., dated April 2, 2004, and recorded in Book 21088, Page 312 of the Cumberland County Registry of Deeds.

The above described parcel is conveyed together with a certain pedestrian easement located on the northwesterly side of Marlborough Street in said City of Portland, as shown on said Subdivision Plan/Recording Plat of Newcomb Glen Subdivision for Gunter-Paul, Inc. by Sebago Technics, Inc. dated February 15, 2002 and last revised August 4, 2003 as described in said deed of Gunter-Paul, Inc. to Windemere Homes LLC, dated April 2, 2004, and recorded in Book 21088, Page 312 of the Cumberland County Registry of Deeds.

The purpose of this deed is to convey the subject property to Grantee to confirm a previous deed from Grantor to Grantee recorded in the Cumberland County Registry of Deeds on August 17, 2005 in Book 23038, Page 1. Said prior deed from Grantor to Grantee came as the result of a Statutory Power of Sale Foreclosure. Due to the fact that the Grantor's affidavit required under 14 M.R.S.A. §6203-B was recorded 33 days after the public sale, the effectiveness of said prior deed was inadequate. Reference is made to a Quitclaim Deed with Covenant in Lieu of Foreclosure of near or even date to be recorded in the Cumberland County Registry of Deeds, a Partial Release of near or even date from Dean Cole to Gunter-Paul, LLC to

be recorded in said Registry, and a Partial Release of near or even date from Gunter-Paul, LLC to Windemere Homes, LLC of near or even date to be recorded in said Registry of Deeds.

TO HAVE AND TO HOLD the aforegranted and bargained premises, with all the privileges and appurtenances thereof, to the said **KING CONSTRUCTION, CORP.** and/or its successors and assigns, to it and its own use and behoof forever.

IN WITNESS WHEREOF, the said George Denney, President of Northeast Trading Corp. has caused these presents to be signed this 28th day of the month of October, A.D., 2005.

**Signed Sealed and Delivered
in the Presence of:**

NORTHEAST TRADING CORP.

Patricia M. Shaw
Witness

George Denney
George Denney, President

STATE OF MAINE
COUNTY OF Cumberland

Oct. 28, 2005

Then personally appeared the above named George Denney, President of Northeast Trading Corp. and acknowledged the foregoing instrument to be his own free act in his said capacity and the free act and deed of said corporation.

Before me,

Patricia M. Shaw
Notary Public/Attorney at Law

PATRICIA M. SHAW
Notary Public, State of Maine
Commission Expires March 29, 2007

SEAL

Print or type name

SMITH ELLIOTT SMITH & GARMEY
P.O. BOX 1179
SACO, ME 04072

3p →

Received
Recorded Register of Deeds
Nov 22, 2005 09:52:36A
Cumberland County
John B O'Brien



Level I – Minor Residential Development Review Application Portland, Maine

Planning and Urban Development Department
Planning Division

Portland's Planning and Urban Development Department coordinates the development review process for site plan, subdivision and other applications under the City's Land Use Code. Attached is the application form for a Level I: Minor Residential site plan and building permit.

Level I: Minor Residential development includes:

- Development of a single-family or a two-family building, excluding building additions, decks, or accessory structures, such development shall be deemed minor residential development for purposes of this article regardless of its size.
- The addition of any additional dwelling unit to a building initially reviewed as a two-family dwelling or multifamily structure, if the additional dwelling unit does not require subdivision review under Maine State Statutes and Portland's Subdivision Ordinance.

As of September 16, 2010 all new construction of one and two family homes are required to be sprinkled in compliance with NFPA 13D. This is required by City Code. (NFPA 101 2009 ed.)

The Maine Home Construction Contracts Act requires that any home construction or repair work for more than \$3000 in materials or labor must be based on a written contract unless the parties agree to exempt themselves. A sample contract is available on the City's website at www.portlandmaine.gov, or contact the Inspections Office to have one mailed to you.

The Land Use Code (including Article V), the Technical Manual, and the Design Manual are available on the City's web site at <http://www.portlandmaine.gov/planning/default.asp> or copies may be purchased at the Planning Division Office.

Inspection Division

Room 315, City Hall
389 Congress Street
(207) 874-8703

Office Hours

Monday, Tuesday, Wednesday and Friday
8:00 a.m. – 4:00 p.m.
Thursday
8:00 a.m. – 1:00 p.m.

Planning Division

Fourth Floor, City Hall
389 Congress Street
(207) 874-8721

Office Hours

Monday thru Friday
8:00 a.m. – 4:30 p.m.

Location/Address of Site: LOT #6 STEPPING STONE LANE		
Total Square Footage of Proposed Structure/Area: 1598 SQFT	Area of lot (total square feet): 8958 SQFT	Number of Stories: 2
Tax Assessor's Chart, Block & Lot(s) Chart# Block # Lot#	Fees Paid: (for Office Use Only) Site Plan _____ Building Permit _____ Inspection _____	Cost of Work: Work: \$ 110,000 C of O Fee \$ _____
Current Legal Use: Number of residential Units SINGLE FAMILY	If vacant, previous use? VACANT LOT	Is property part of a subdivision? If yes, please name: AUTUMN GREEN SOB
Proposed Use and Project Description: 3 BEDROOM RANCH		
Applicant – must be owner, Lessee or Buyer Name: DWIGHT BRACKETT Business Name, if applicable: Address: 84 COUNTRY LANE City/State: PORTLAND ME Zip Code: 04103		Applicant Contact Information Work # 7560687 Home# Cell # e-mail:
Owner – (if different from Applicant) Name: D.A. BRACKETT CO INC Address: 84 COUNTRY LANE City/State: PORTLAND ME Zip Code: 04103		Owner Contact Information Work # Home# Cell # e-mail:
Agent/ Contractor Name: Address: City/State : Zip Code:		Agent/Contractor Contact Information Work # Home# Cell # e-mail:
Billing Information Name: Address: City/State : Zip Code: Phone Number:		Contact when Building Permit is Ready: Name: DWIGHT BRACKETT Address: 84 COUNTRY LANE City/State : PORTLAND ME Zip Code: 04103 Phone Number:

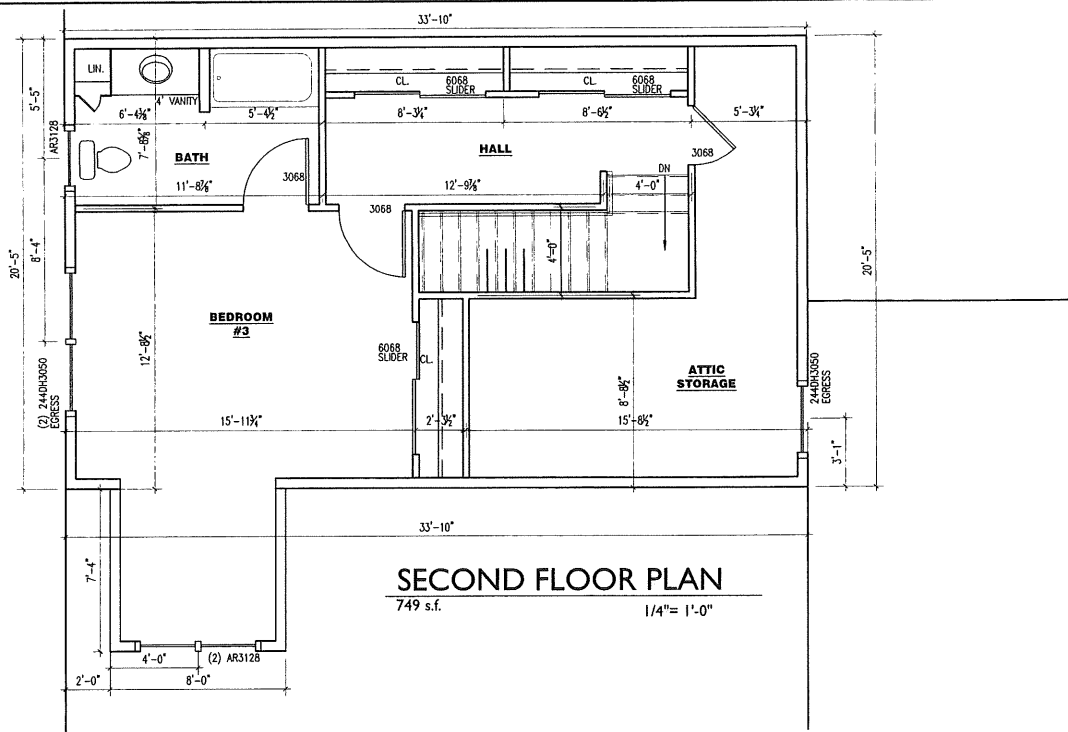

SECOND FLOOR PLAN
749 s.f. 1/4" = 1'-0"

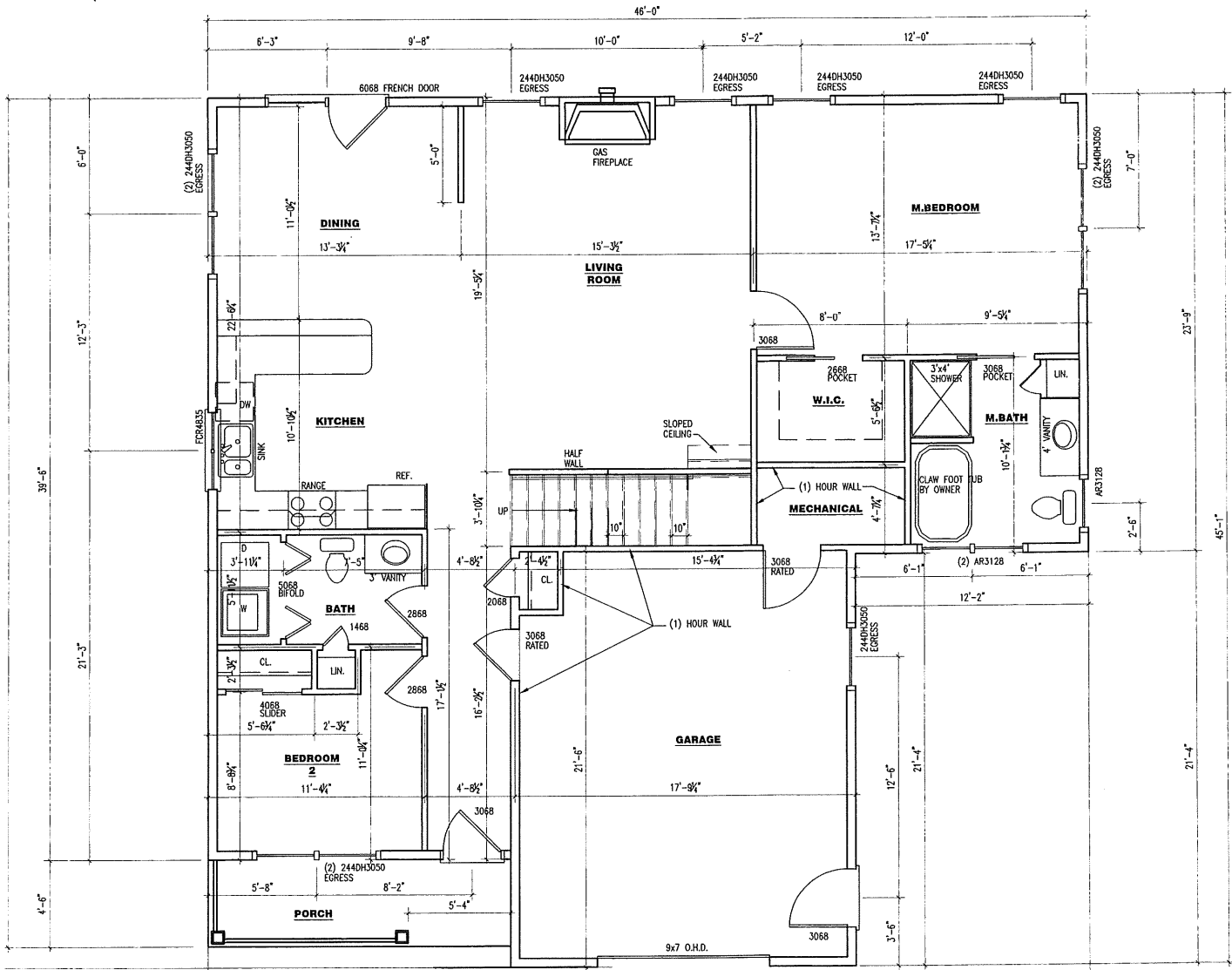

FIRST FLOOR PLAN
1,316 s.f. 1/4" = 1'-0"

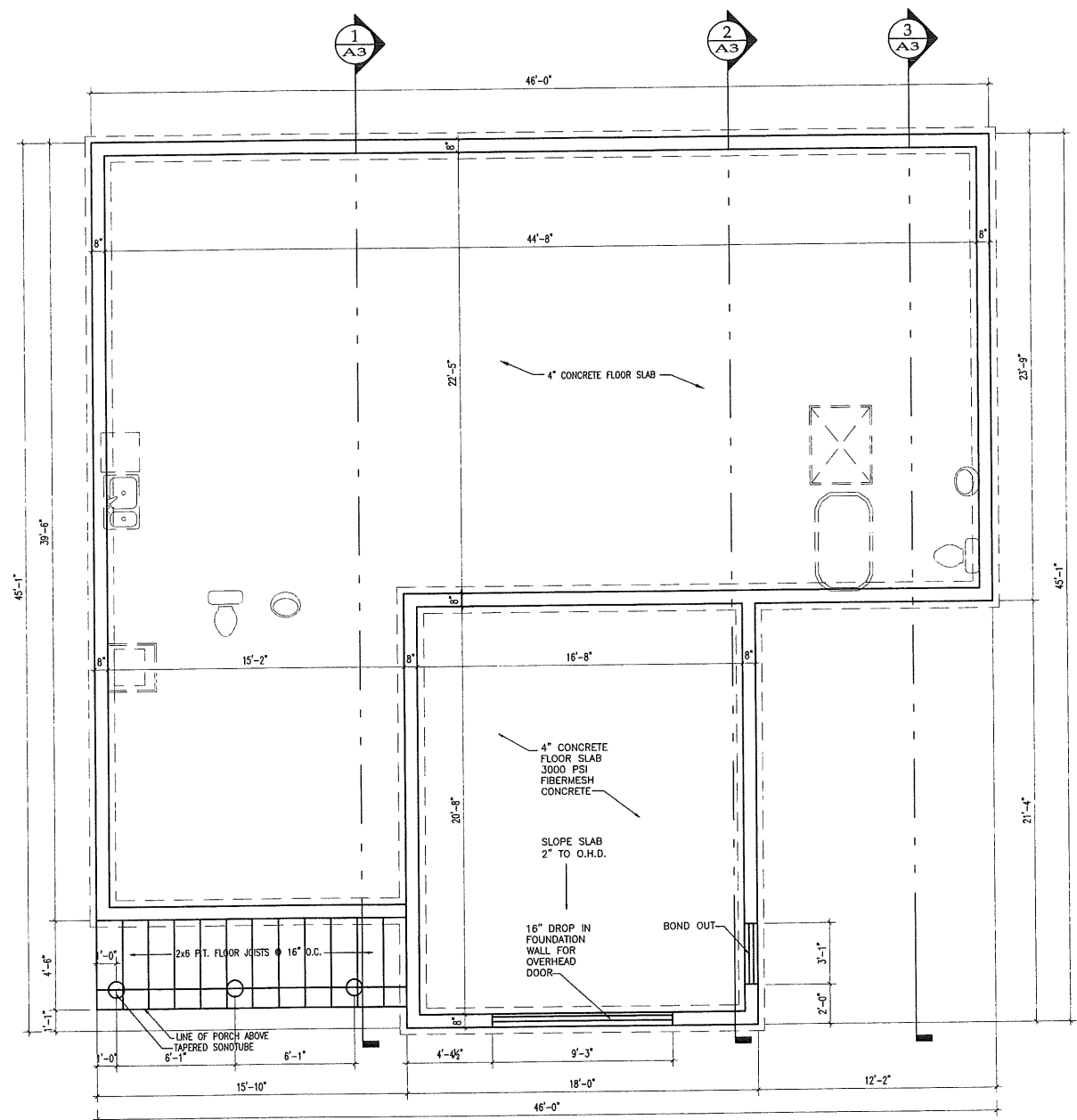

FOUNDATION PLAN
1/4" = 1'-0"

29 Stepping Stone Lane

Private Residence
Portland, Maine

DRAWINGS THIS SHEET
FLOOR PLANS
FOUNDATION PLAN
02/17/11

A1

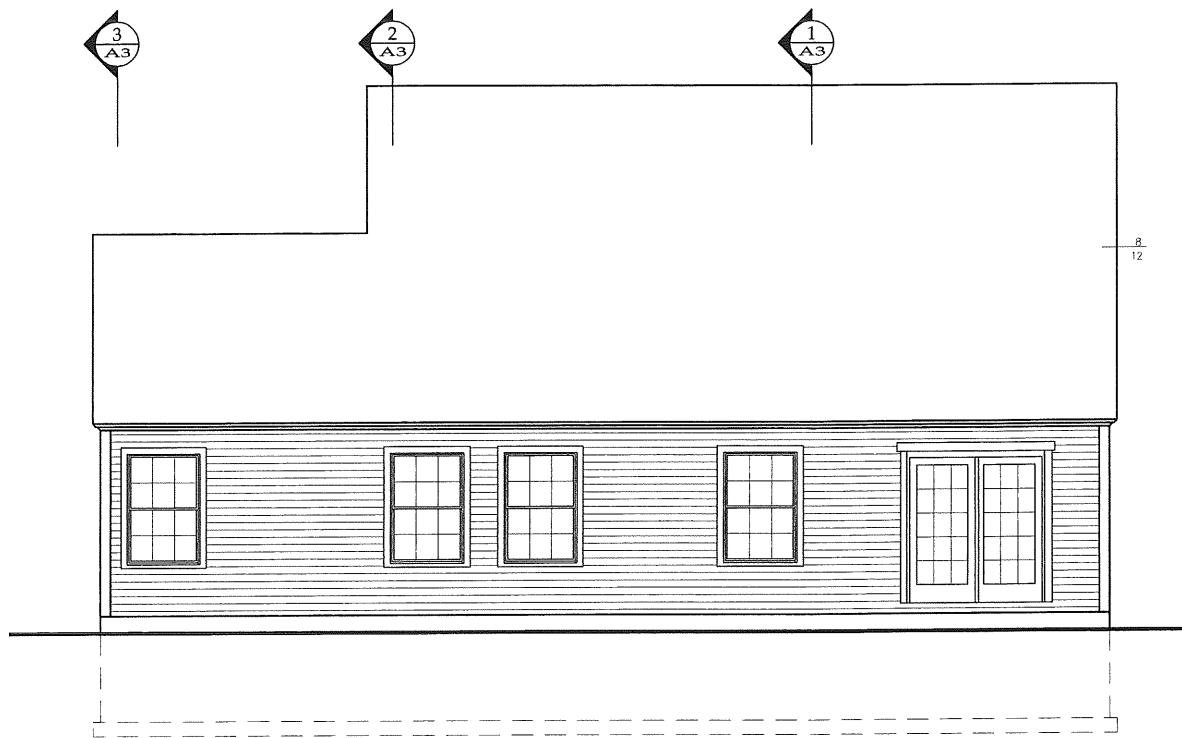

REAR ELEVATION

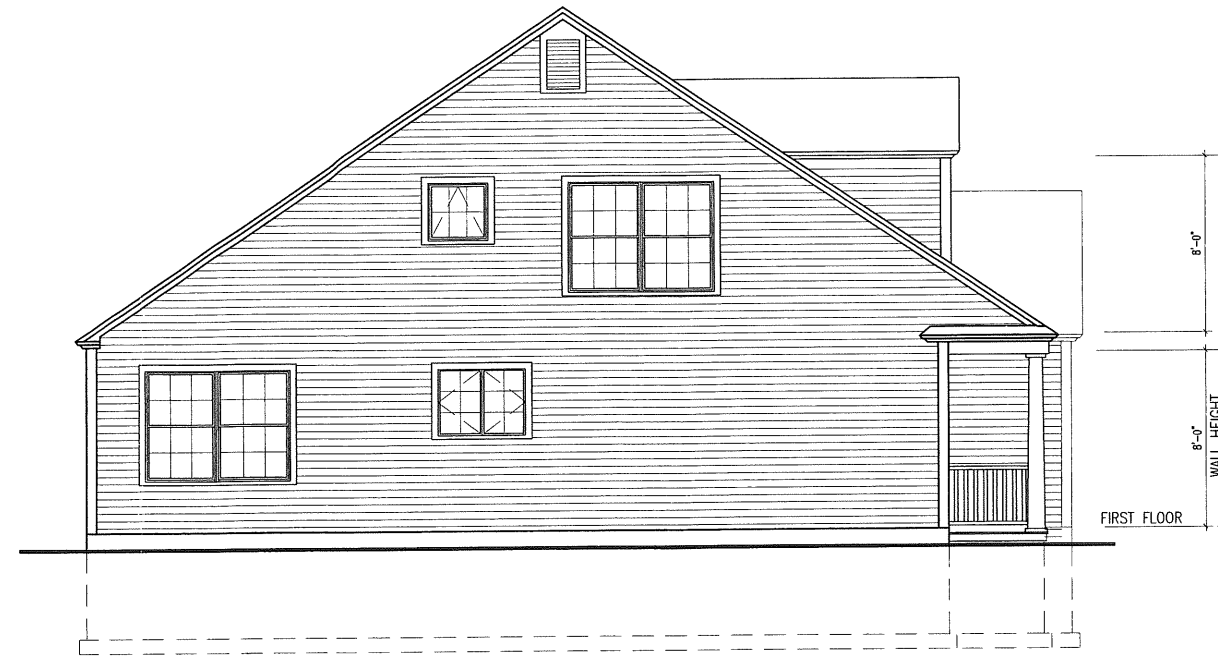

LEFT SIDE ELEVATION

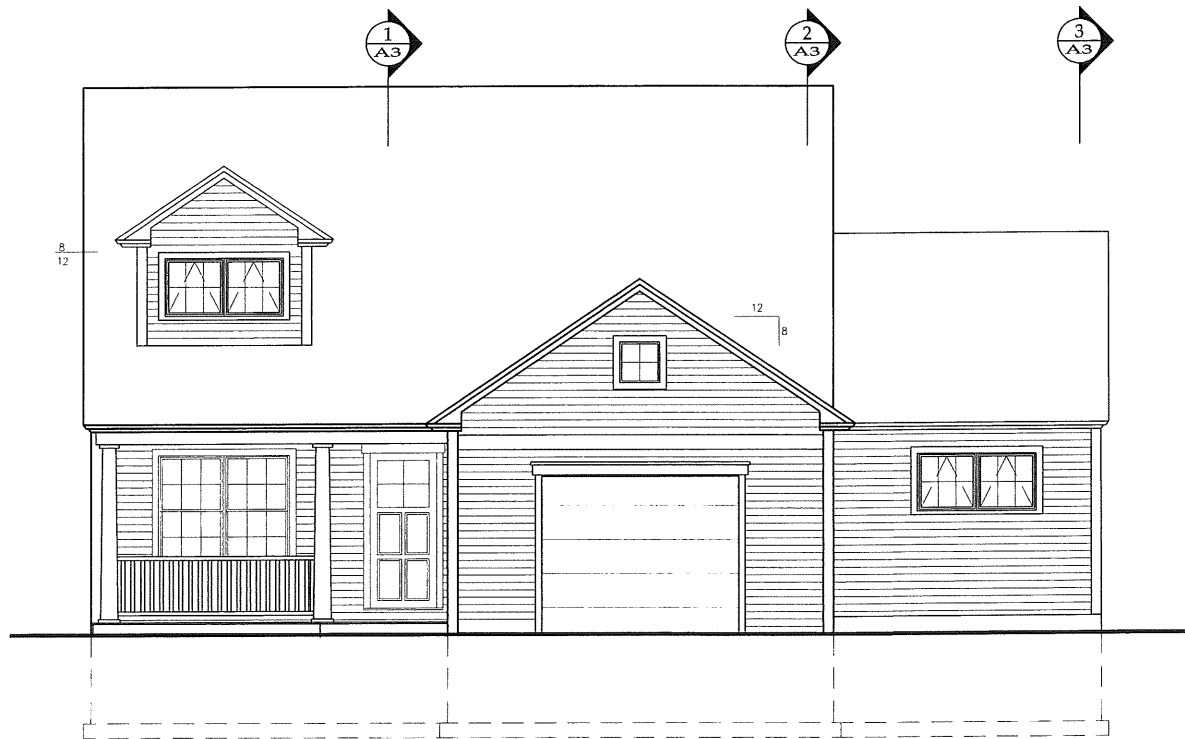

FRONT ELEVATION



RIGHT SIDE ELEVATION

1/4" = 1'-0"

Private Residence	
Portland, Maine	
DRAWINGS THIS SHEET	
ELEVATIONS	
02/17/11	A2

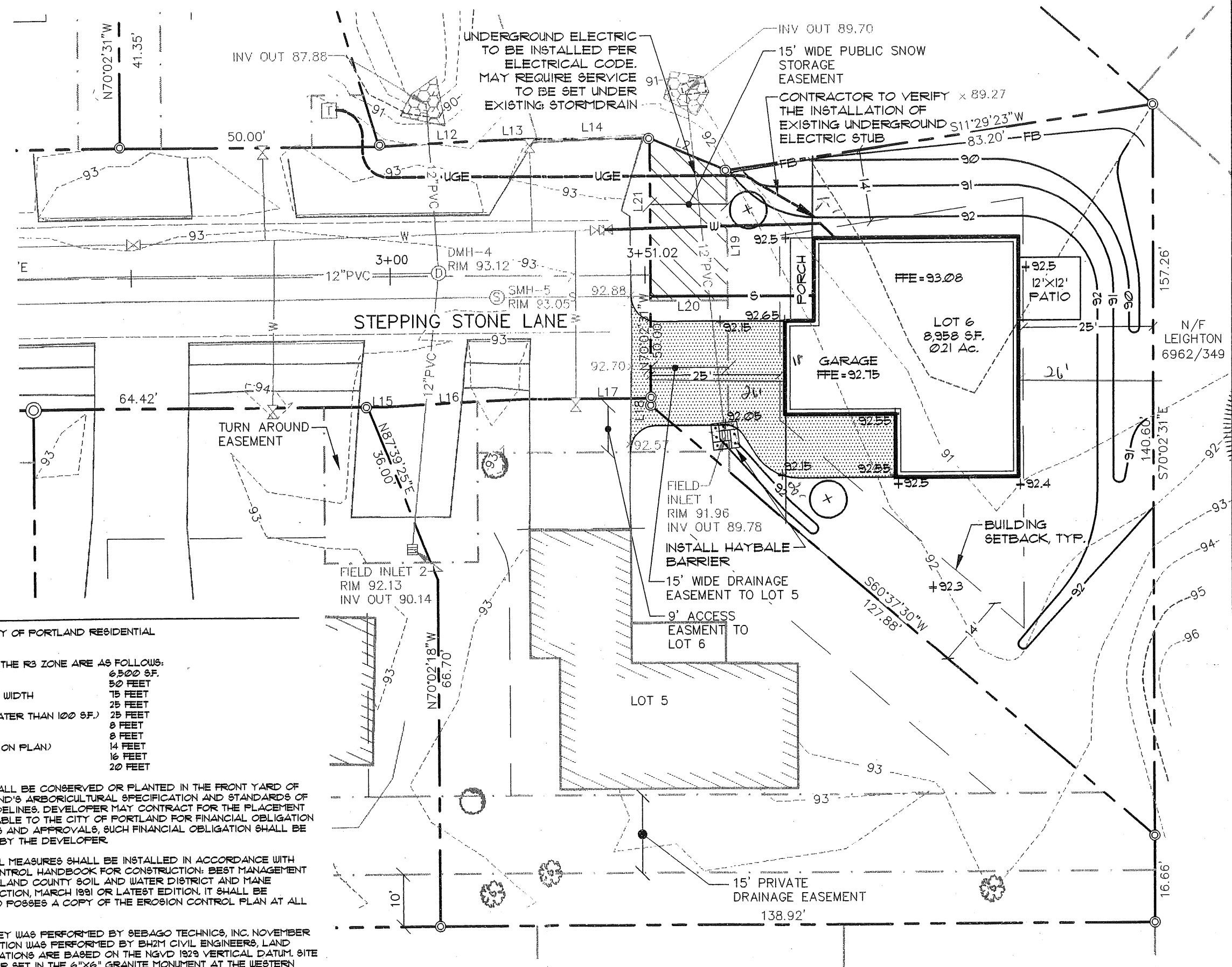
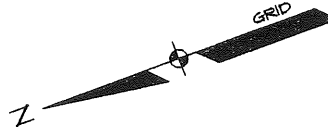

- NOTES:**
1. THE PROPERTY IS LOCATED IN THE CITY OF PORTLAND RESIDENTIAL (R3) ZONE.
 2. THE DIMENSIONAL REQUIREMENTS FOR THE R3 ZONE ARE AS FOLLOWS:
 MINIMUM LOT SIZE 6,500 SF.
 MINIMUM STREET FRONTAGE 50 FEET
 MINIMUM YARD DIMENSIONS: MIN. LOT WIDTH 15 FEET
 FRONT YARD 25 FEET
 REAR YARD (STRUCTURES GREATER THAN 100 SF.) 25 FEET
 SIDE YARD (1 STORY) 8 FEET
 (1 1/2 STORY) 8 FEET
 (2 STORY-SHOWN ON PLAN) 14 FEET
 (2 1/2 STORY) 16 FEET
 SIDE YARD (ON SIDE STREET) 20 FEET
 3. A MINIMUM OF TWO TREES PER LOT SHALL BE CONSERVED OR PLANTED IN THE FRONT YARD OF EACH LOT MEETING THE CITY OF PORTLAND'S ARBORICULTURAL SPECIFICATION AND STANDARDS OF PRACTICE AND LANDSCAPE DESIGN GUIDELINES. DEVELOPER MAY CONTRACT FOR THE PLACEMENT OF LANDSCAPING, BUT SHALL REMAIN LIABLE TO THE CITY OF PORTLAND FOR FINANCIAL OBLIGATION FOR COMPLIANCE WITH CITY ORDINANCES AND APPROVALS, SUCH FINANCIAL OBLIGATION SHALL BE NEITHER TRANSFERABLE NOR WAIVABLE BY THE DEVELOPER.
 4. ALL EROSION AND SEDIMENT CONTROL MEASURES SHALL BE INSTALLED IN ACCORDANCE WITH "MAINE EROSION AND SEDIMENTATION CONTROL HANDBOOK FOR CONSTRUCTION: BEST MANAGEMENT PRACTICES" PUBLISHED BY THE CUMBERLAND COUNTY SOIL AND WATER DISTRICT AND MAINE DEPARTMENT OF ENVIRONMENTAL PROTECTION, MARCH 1991 OR LATEST EDITION. IT SHALL BE RESPONSIBILITY OF THE CONTRACTOR TO POSSESS A COPY OF THE EROSION CONTROL PLAN AT ALL TIMES.
 5. TOPOGRAPHIC AND BOUNDARY SURVEY WAS PERFORMED BY SEBAGO TECHNICS, INC. NOVEMBER 2001. ON THE GROUND AS-BUILT INFORMATION WAS PERFORMED BY BH2M CIVIL ENGINEERS, LAND SURVEYORS AND LAND PLANNERS. ELEVATIONS ARE BASED ON THE NGVD 1929 VERTICAL DATUM. SITE BENCHMARK IS A BRASS PLATE & WASHER SET IN THE 6"X6" GRANITE MONUMENT AT THE WESTERN SIDE OF THE INTERSECTION OF BEAUREGARD STREET AND STEPPING STONE LANE, ELEVATION=92.21

Sebago Technics
 Engineering Expertise You Can Build On

One Chabot Street
 Westbrook, ME 04098-1339
 Tel (207) 856-0277

250 Goddard Road - Suite B
 Lewiston, ME 04240
 Tel (207) 783-6666

WWW.SEBAGOTECHNICS.COM

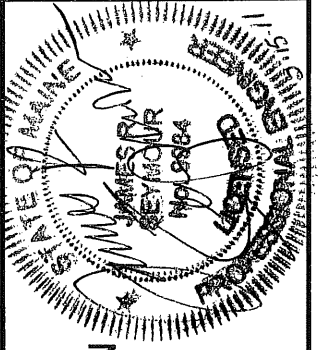

LOT PLAN 29 Stepping Stone Lane
 OF: LOT 6 AUTUMN GLEN SUBDIVISION
 STEPPING STONE LANE
 PORTLAND, MAINE
 FOR: DWIGHT BRACKETT
 48 COUNTRY LANE
 PORTLAND, MAINE 04103

DESIGN BY:	JRS
DRAWN BY:	JRH
CHECKED BY:	JRS
DATE:	2-8-11
SCALE:	1"=20'
FIELD BK:	772
PROJ. NO:	10446
DWG:	10446SK

SHEET 1 OF 1

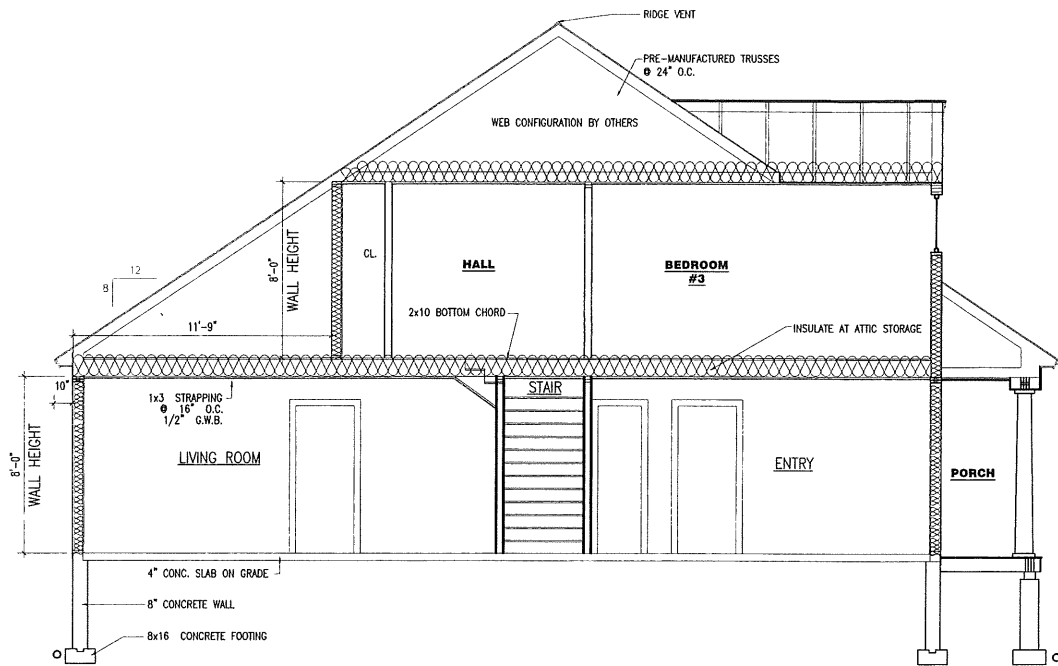

1 BUILDING SECTION
1/4" = 1'-0"

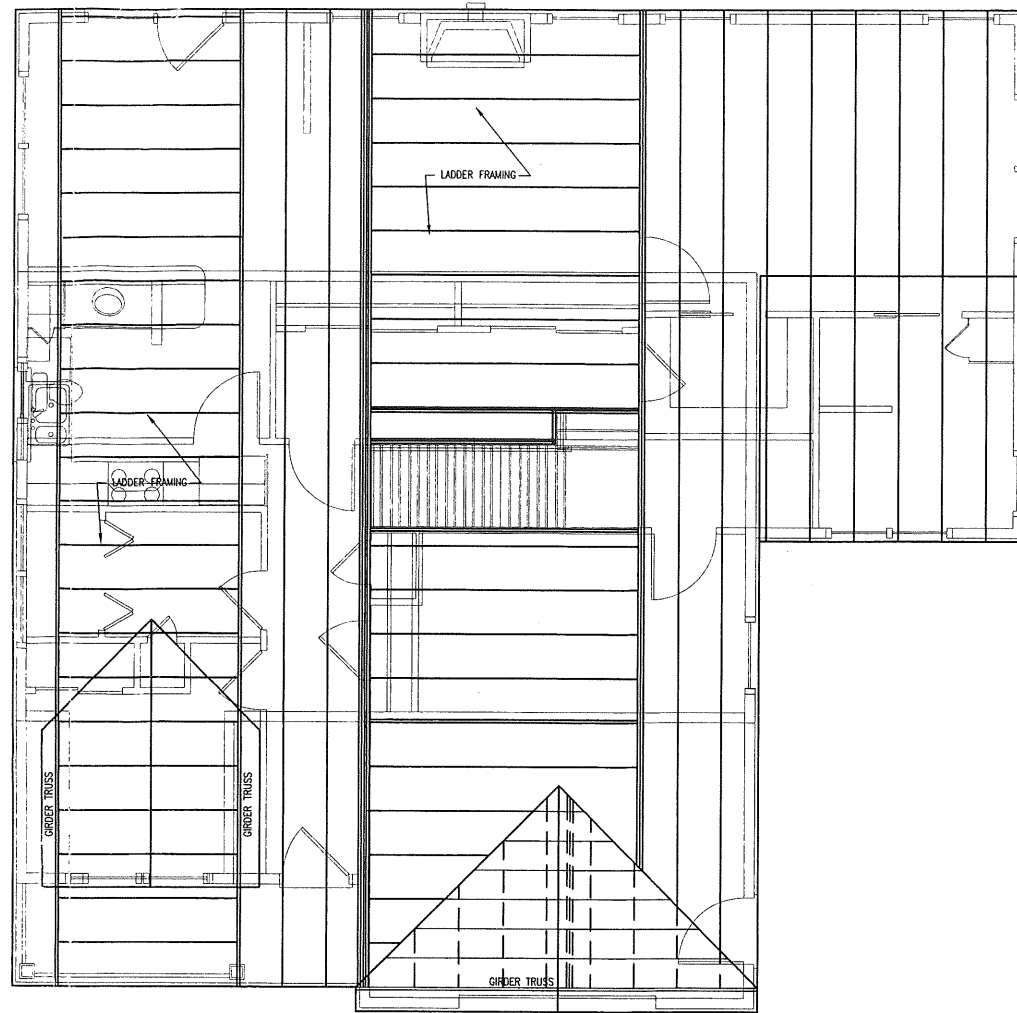

ROOF PLAN
1/4" = 1'-0"

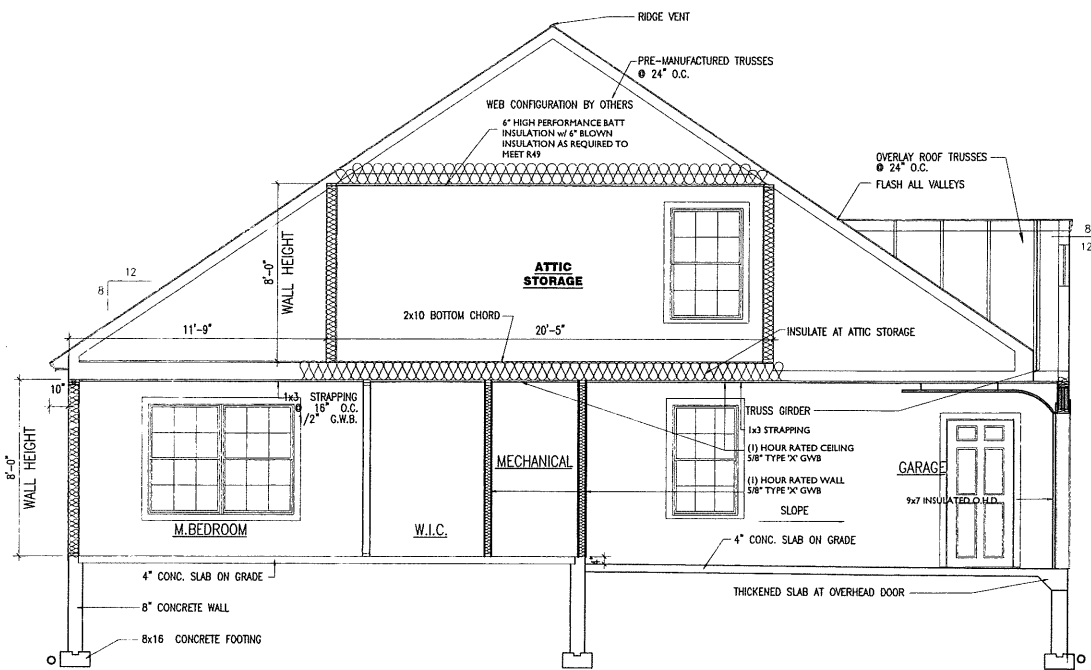

2 BUILDING SECTION
1/4" = 1'-0"

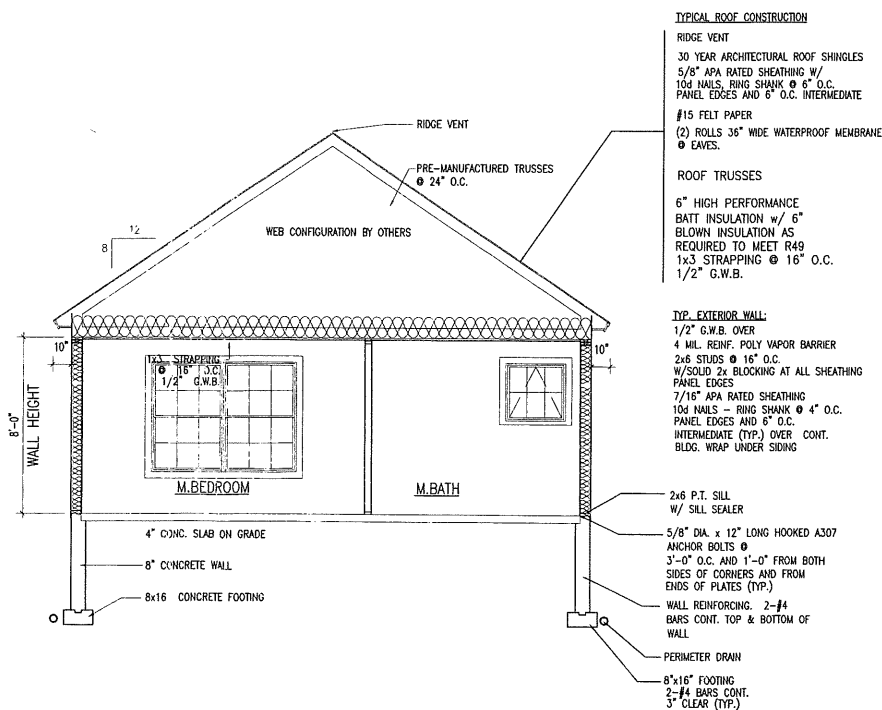

3 BUILDING SECTION
1/4" = 1'-0"

TYPICAL ROOF CONSTRUCTION

- RIDGE VENT
- 30 YEAR ARCHITECTURAL ROOF SHINGLES
- 5/8" APA RATED SHEATHING W/
10d NAILS, RING SHANK @ 6" O.C.
PANEL EDGES AND 6" O.C. INTERMEDIATE
- #15 FELT PAPER
- (2) ROLLS 36" WIDE WATERPROOF MEMBRANE
@ EAVES.
- ROOF TRUSSES
- 6" HIGH PERFORMANCE
BATT INSULATION w/ 6"
BLOWN INSULATION AS
REQUIRED TO MEET R49
- 1x3 STRAPPING @ 16" O.C.
1/2" G.W.B.

INT. EXTERIOR WALL:

- 1/2" G.W.B. OVER
- 4 MIL. REIN. POLY VAPOR BARRIER
- 2x6 STUDS @ 16" O.C.
W/SOLID 2x BLOCKING AT ALL SHEATHING
PANEL EDGES
- 7/16" APA RATED SHEATHING
- 10d NAILS - RING SHANK @ 4" O.C.
PANEL EDGES AND 6" O.C.
INTERMEDIATE (TYP.) OVER CONT.
BLDG. WRAP UNDER SIDING
- 2x6 P.T. SILL
W/ SILL SEALER
- 5/8" DIA. x 12" LONG HOOKED A307
ANCHOR BOLTS @
3'-0" O.C. AND 1'-0" FROM BOTH
SIDES OF CORNERS AND FROM
ENDS OF PLATES (TYP.)
- WALL REINFORCING. 2-#4
BARS CONT. TOP & BOTTOM OF
WALL
- PERIMETER DRAIN
- 8"x16" FOOTING
2-#4 BARS CONT.
3" CLEAR (TYP.)

Private Residence
Portland, Maine

DRAWINGS THIS SHEET
SECTIONS/DETAILS

A