

SOUTH SIDE

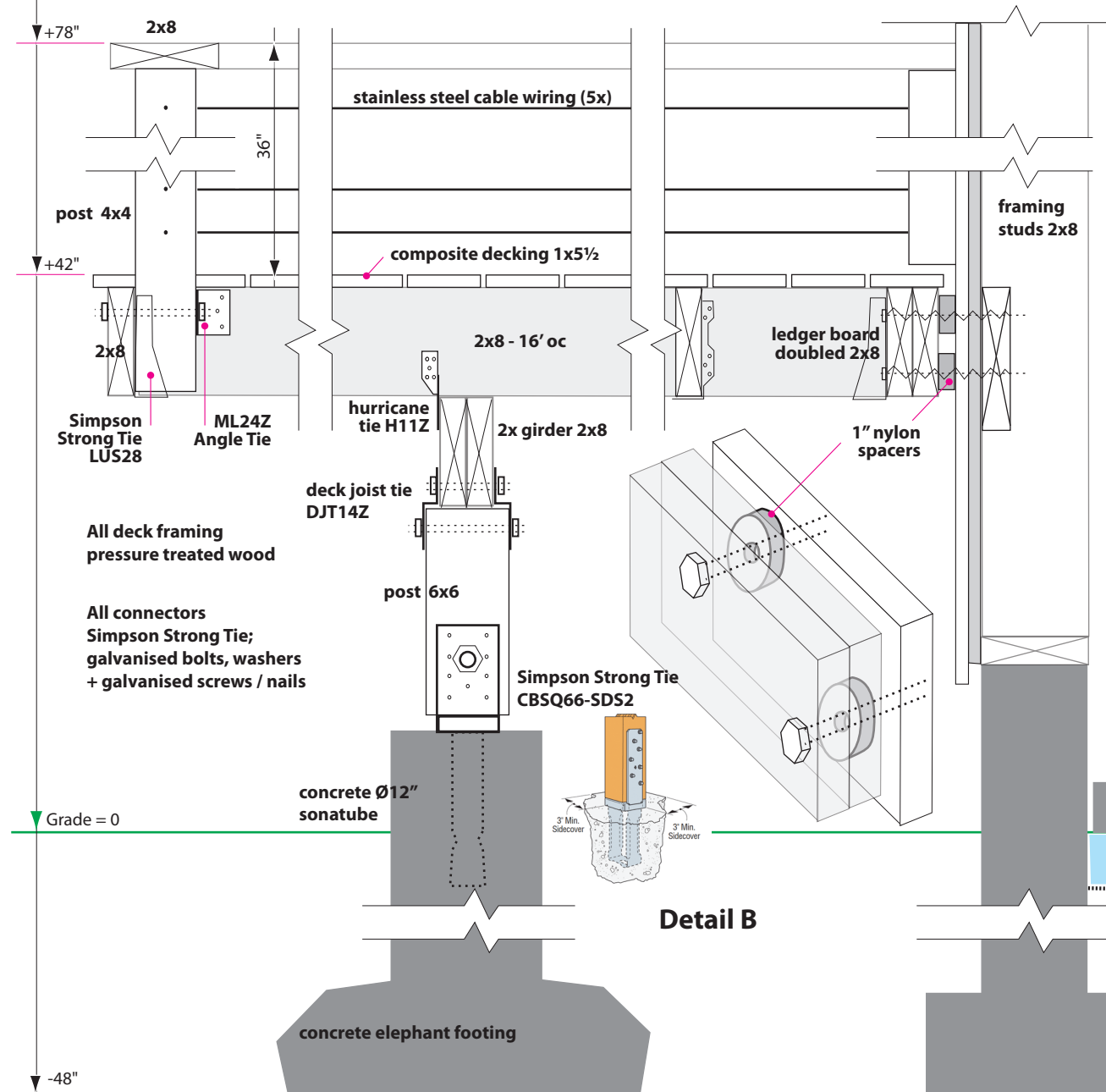

Detail B

Detail A - A



EAST SIDE (BACK)

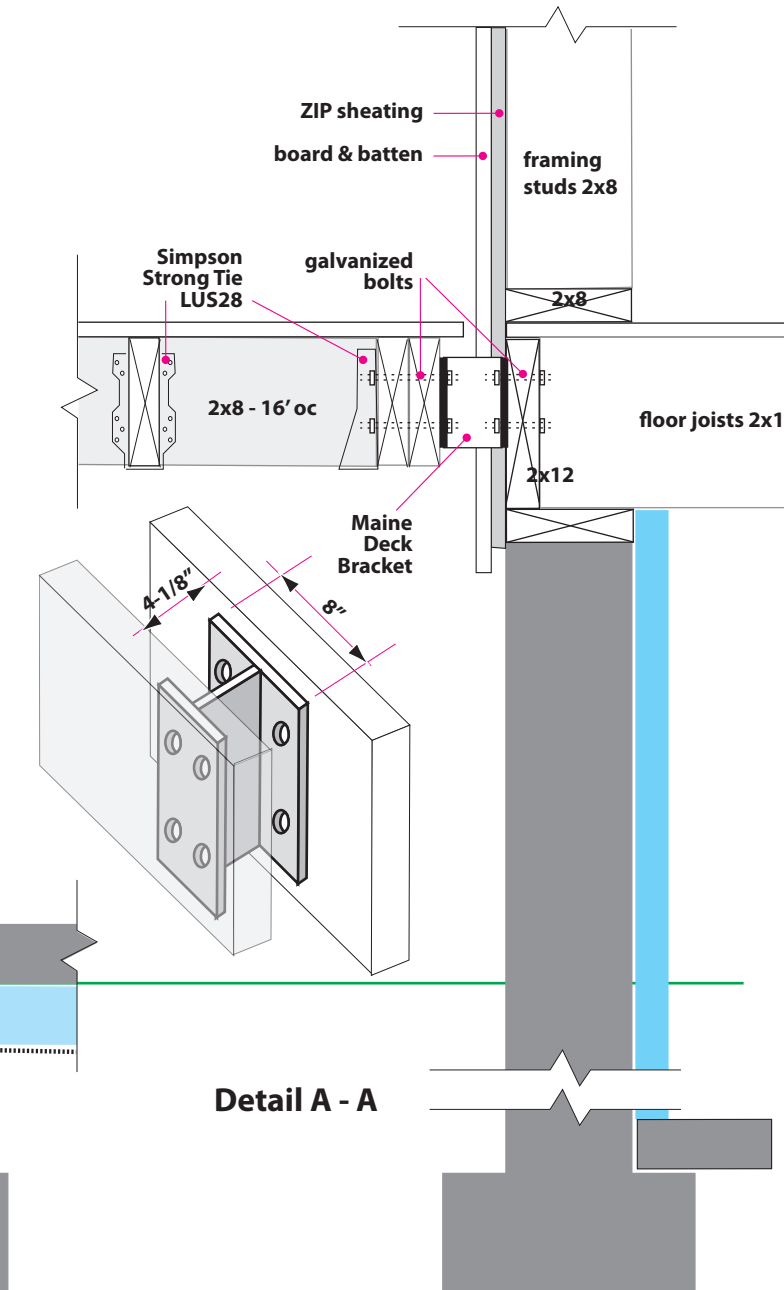

NEW DECK



DEED BOOK: 3191, PAGE 488
 PLAN BOOK: 17, PAGE 6
 COUNTY: CUMBERLAND
 LOT: 1103 & 1104 + part of 1106 & 1107
 DIVISION 4 R-3 RESIDENTIAL ZONE

December 2014
 131 Virginiastreet, Portland, Maine
 PROPERTY OF: STONE-RUKS

SHEET 14