

DISPLAY THIS CARD ON PRINCIPAL FRONTAGE OF WORK CITY OF PORTLAND

Please Read Application And Notes, If Any, Attached

BUILDING INSPECTION

PERMIT

Permit Number: 060182

This is to certify that ALLING KAREN I/Dave's Tools
has permission to install a 24' Diameter pool
AT 101 VERMONT A W, 5A J019001

provided that the person or persons who accept this permit shall comply with all of the provisions of the Statutes of the State and of the Ordinances of the City of Portland regulating the construction, maintenance and use of buildings and structures, and of the application on file in this department.

Apply to Public Works for street line and grade if nature of work requires such information.

Notification of inspection must be given and when permission procured before this building or part thereof is leased or enclosed-in. 24 HOUR NOTICE IS REQUIRED.

A certificate of occupancy must be procured by owner before this building or part thereof is occupied.

PERMIT ISSUED
OTHER REQUIRED APPROVALS
MAR 28 2006
CITY OF PORTLAND
Department Name

Fire Dept.
Health Dept.
Appeal Board
Other

[Signature] 3/28/06
Director - Building & Inspection Services

PENALTY FOR REMOVING THIS CARD

PERMIT ISSUED

City of Portland, Maine - Building or Use Permit Application

389 Congress Street, 04101 Tel: (207) 874-8703, Fax: (207) 874-8716

Permit N 182	Issue Date: MAR 28 2006	CHL: 405A 0019001
-----------------	-----------------------------------	----------------------

Location of Construction: 101 VERMONT AVE	Owner Name: ALLING KAREN J	Owner Address: 101 VERMONT AVE	Phone:
Business Name:	Contractor Name: Dave's Pools	Contractor Address: 690 Main St Westbrook	Phone: 2078545006
Lessee/Buyer's Name	Phone:	Permit Type: Swimming Pools	Zone:

Past Use: Single Family Home	Proposed Use: Single Family Home/ install a 24' Diameter pool	Permit Fee: \$57.00	Cost of Work: \$4,000.00	CEO District: 1
--	---	-------------------------------	------------------------------------	---------------------------

Proposed Project Description:
install a 24' Diameter pool

FIRE DEPT: <input type="checkbox"/> Approved <input type="checkbox"/> Denied <i>N/A</i> Signature	INSPECTION: Use Group: <i>2-3/0</i> Type: <i>5B</i> <i>IRC 2003</i> Signature:
PEDESTRIAN ACTIVITIES DISTRICT (P.A.D.)	
Action <input type="checkbox"/> Approved <input type="checkbox"/> Approved w/Conditions <input type="checkbox"/> Denied	
Signature	Date

Permit Taken By: Idobson	Date Applied For: 02/06/2006	Zoning Approval
------------------------------------	--	------------------------

<ol style="list-style-type: none"> This permit application does not preclude the Applicant(s) from meeting applicable State and Federal Rules. Building permits do not include plumbing, septic or electrical work. Building permits are void if work is not started within six (6) months of the date of issuance. False information may invalidate a building permit and stop all work.. 	Special Zone or Reviews <input type="checkbox"/> Shoreland <input type="checkbox"/> Wetland <input type="checkbox"/> Flood Zone <input type="checkbox"/> Subdivision <input type="checkbox"/> Site Plan Maj <input type="checkbox"/> Minor <input type="checkbox"/> MM <input type="checkbox"/> Date: <i>3/28/06</i>	Zoning Appeal <input type="checkbox"/> Variance <input type="checkbox"/> Miscellaneous <input type="checkbox"/> Conditional Use <input type="checkbox"/> Interpretation <input type="checkbox"/> Approved <input type="checkbox"/> Denied Date:	Historic Preservation <input checked="" type="checkbox"/> Not in District or Landmark <input type="checkbox"/> Does Not Require Review <input type="checkbox"/> Requires Review <input type="checkbox"/> Approved <input type="checkbox"/> Approved w/Conditions <input type="checkbox"/> Denied Date: <i>3/28/06</i>
---	--	---	---

CERTIFICATION

I hereby certify that I am the owner of record of the named property, or that the proposed work is authorized by the owner of record and that I have been authorized by the owner to make this application as his authorized agent and I agree to conform to all applicable laws of this jurisdiction. In addition, if a permit for work described in the application is issued, I certify that the code official's authorized representative shall have the authority to enter all areas covered by such permit at any reasonable hour to enforce the provision of the code(s) applicable to such permit.

SIGNATURE OF APPLICANT	ADDRESS	DATE	PHONE
RESPONSIBLE PERSON IN CHARGE OF WORK, TITLE		DATE	PHONE

BUILDING PERMIT INSPECTION PROCEDURES

Please call 874-8703 or 874-8693 to schedule your inspections as agreed upon

Permits expire in 6 months, if the project is not started or ceases for 6 months.

The Owner or their designee is required to notify the inspections office for the following inspections and provide adequate notice. Notice must be called in 48-72 hours in advance in order to schedule an inspection:

By initializing at each inspection time, you are agreeing that you understand the inspection procedure and additional fees from a "Stop Work Order" and "Stop Work Order Release" will be incurred if the procedure is not followed as stated below.

A Pre-construction Meeting will take place upon receipt of your building permit.

- Footings/Building Location Inspection: ~~Prior to pouring concrete~~
- Re-Bar Schedule Inspection: Prior to pouring concrete
- Foundation Inspection: Prior to placing ANY backfill
- Framing/Rough Plumbing/Electrical: Prior to any *backfill*
- Final/Certificate of Occupancy: Prior to any occupancy of the structure or use. NOTE: There is a \$75.00 fee per inspection at this point.

Certificate of Occupancy is not required for certain projects. Your inspector can advise you if your project requires a Certificate of Occupancy. **All** projects DO require a final inspection

If any of the inspections do not occur, the project cannot go on to the next phase, REGARDLESS OF THE NOTICE OR CIRCUMSTANCES.

CERIFICATE OF OCCUPANICES MUST BE ISSUED AND PAID FOR, BEFORE THE SPACE MAY BE OCCUPIED

[Signature]
Signature of Applicant/Designee

Date
3/28/06

Signature of Inspections Official

Date

CBL: 405-AJ 019

Building Permit #: 06 0182

protection as that provided by a swimming pool enclosure barrier. The following requirements are represented

1. There should be a means of fastening the safety cover to the hot tub or spa, such as key locks, combination locks, special tools or similar devices

that will prohibit children from removing or operating the cover. The fastening mechanism, design, and location are vital components that

2. The safety cover should have a label that provides a warning and message regarding the risk of drowning. The label is also very important for

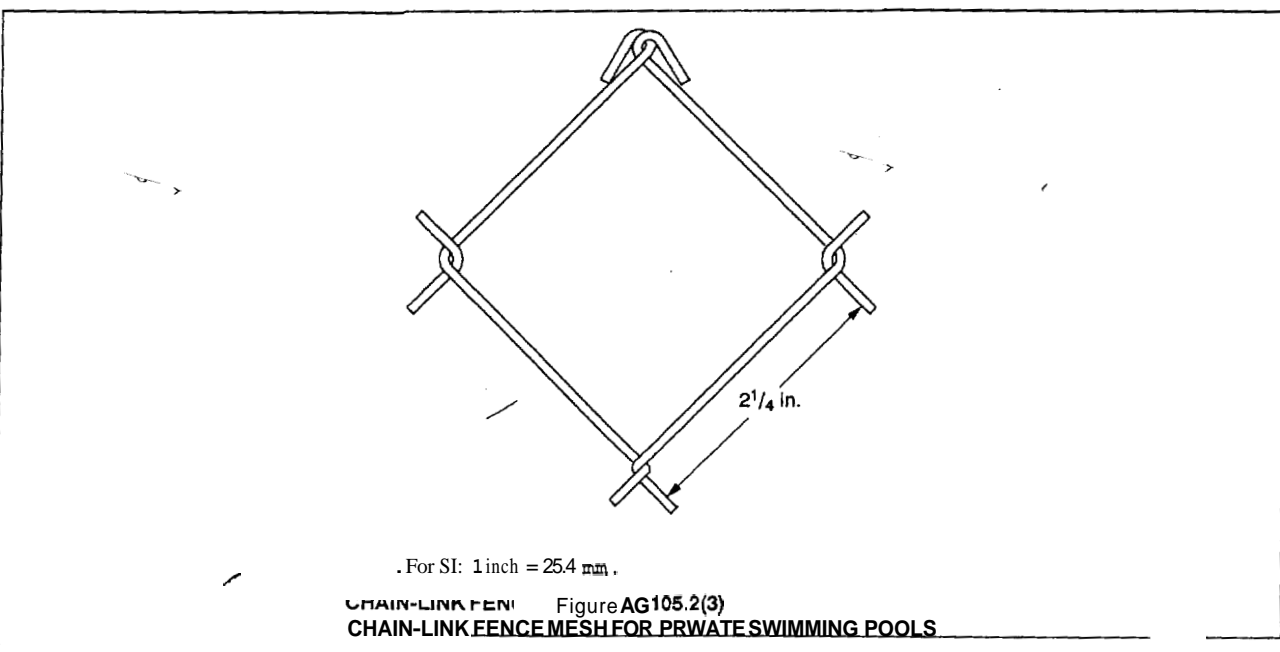
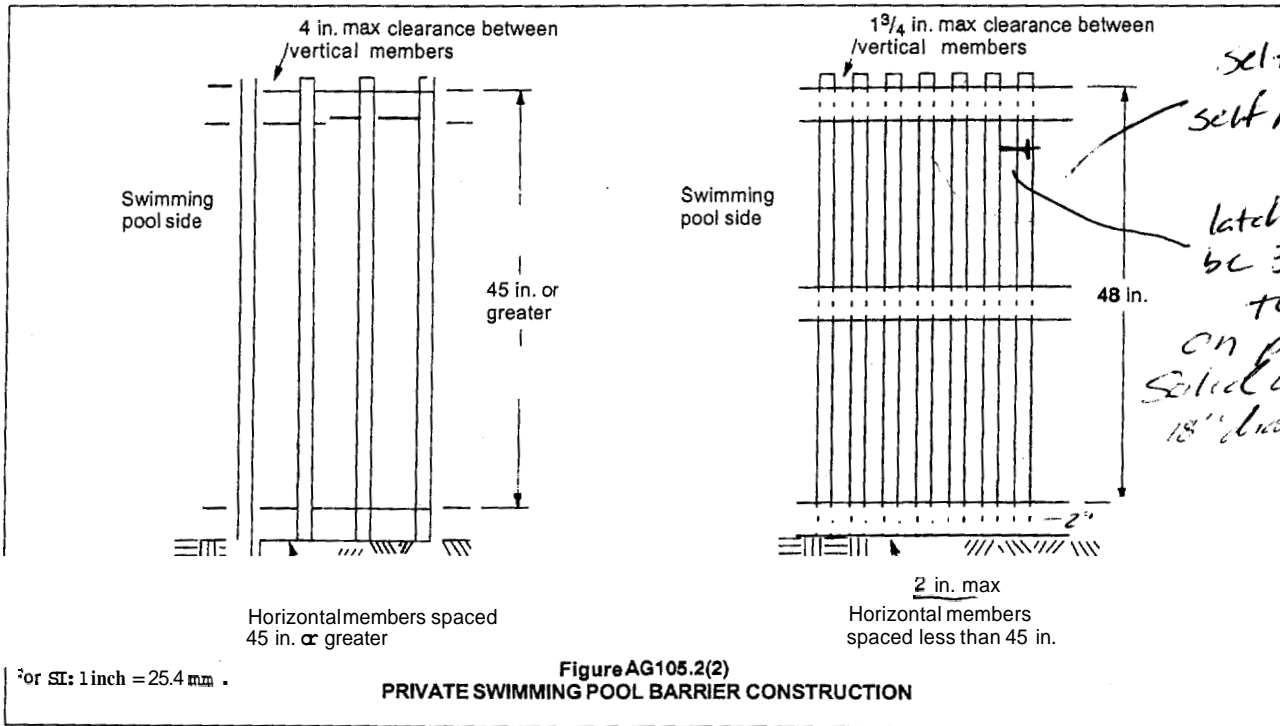

City of Portland, Maine - Building or Use Permit

389 Congress Street, 04101 Tel: (207) 874-8703, Fax: (207) 874-8716

Permit No: 06-0182	Date Applied For: 02/06/2006	CBL: 405A J019001
------------------------------	--	-----------------------------

Location of Construction: 101 VERMONT AVE	Owner Name: ALLING KAREN J	Owner Address: 101 VERMONT AVE	Phone:
Business Name:	Contractor Name: Dave's Pools	Contractor Address: 690 Main St Westbrook	Phone (207) 854-5006
Lessee/Buyer's Name	Phone:	Permit Type: Swimming Pools	

Proposed Use: Single Family Home/ install a 24' Diameter pool	Proposed Project Description: install a 24' Diameter pool
---	---

Dept: Zoning Status: Approved Reviewer: Tammy Munson Approval Date: 0312812006
 Note: Ok to Issue:

Dept: Building Status: Approved with Conditions Reviewer: Tammy Munson Approval Date: 0312812006
 Note: Ok to Issue:

- 1) Separate permits are required for any electrical, plumbing, or heating.
- 2) Permit approved based on the plans submitted and reviewed w/owner/contractor, with additional information as agreed on and as noted on plans.

Comments:

3/14/06-tmm: left message w/owner - need guard info regarding area of pool that abutts deck

Pool Installation/Construction Permit Application

If You or the property owner owes real estate or personal property taxes or user charges on any property within the City, payment arrangements must be made before permits of any kind are accepted.

Location/Address of Construction: <u>101 Vermont Ave. Portland ME 04103</u>		
Total Square Footage of Proposed Structure	Square Footage of Lot <u>8,000</u>	
Tax Assessor's Chart, Block & Lot Chart# <u>40.54</u> Block# <u>5</u> Lot# <u>19</u>	Owner: <u>Karen J. Allina</u>	Telephone: <u>797-2660</u>
Lessee/Buyer's Name (if Applicable)	Applicant name, address & telephone: <u>Karen Allina</u> <u>101 Vermont Ave.</u> <u>Portland ME 04103</u> <u>9-3</u>	cost of Work: \$ <u>4,000.00</u> Fee: \$ <u>57.00</u>
Dimensions of pool: <u>24 ft dia</u> Above or below ground: <u>above</u>		
Dimensions of decking and/or any platforms, sheds, or other structures: <u>deck = 24' x 14'</u> <u>shed = 11' 9" x 7' 8 1/2"</u> , <u>shed = 8' 3 1/2" x 12' 3"</u>		
Contractor's name, address & telephone: <u>Dave's Pool, 690 main St, Westbrook, ME</u> <u>854-5006</u> <u>04092</u>		
Whom should we contact when the permit is ready: <u>Karen Allina</u>		
Mailing address: <u>101 Vermont Ave.</u> <u>Portland ME 04103</u>		
We will contact you by phone when the permit is ready. You must come in and pick up the permit and review the requirements before starting any work, with a Plan Reviewer. A stop work order will be issued and a \$100.00 fee if any work starts before the permit is picked up. PHONE: <u>797-2660</u>		

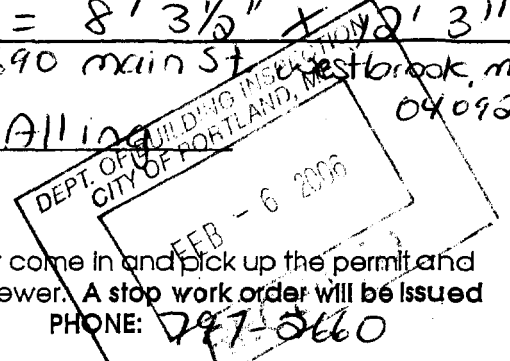

IF THE REQUIRED INFORMATION IS NOT INCLUDED IN THE SUBMISSIONS THE PERMIT WILL BE AUTOMATICALLY DENIED AT THE DISCRETION OF THE BUILDING/PLANNING DEPARTMENT, WE MAY REQUIRE ADDITIONAL INFORMATION IN ORDER TO APPROVE THIS PERMIT.

I hereby certify that I am the Owner of record of the named property, or that the owner of record authorizes the proposed work and that I have been authorized by the owner to make this application as his/her authorized agent. I agree to conform to all applicable laws of this jurisdiction. In addition, if a permit for work described in this application is issued, I certify that the Code Official's authorized representative shall have the authority to enter all areas covered by this permit at any reasonable hour to enforce the provisions of the codes applicable to this permit.

Signature of applicant: <u>Karen J Allina</u>	Date: <u>3-5-06</u>
---	---------------------

This is NOT a permit; you may not commence ANY work until the permit is issued.
If you are in a Historic District you may be subject to additional permitting and fees with the Planning Department on the 4th floor of City Hall

INSPECTION PLAN

I HEREBY CERTIFY TO
 GRANITE TITLE SERVICES
 MORTGAGE NETWORK, INC.
 AND ITS TITLE INSURER

THE BUILDING SETBACKS ARE
 IN CONFORMITY WITH THE
 TOWN ZONING REQUIREMENTS
 THE DWELLING DOES NOT FALL
 WITHIN THE SPECIAL FLOOD
 HAZARD AREA AS DELINIATED BY
 F.E.M.A.

THE LAND DOES NOT FALL
 WITHIN THE SPECIAL FLOOD
 HAZARD AREA AS DELINIATED
 BY F.E.M.A. ON COMMUNITY/
 PANEL # 230051 0002 C

LOCUS ADDRESS

VERMONT AVENUE
 PORTLAND, MAINE

BUYER: KAREN J. ALLING

SELLERS: MICHAEL R. AND
 CHRISTINE W. RIDGE

NORTHEASTERN LAND
 SURVEYING

134 SCHOOL STREET
 GORHAM, MAINE 04038
 PHONE (207) 839-2090
 FAX (207) 839-6361

JOB NUMBER 144-69
 INSPECTION DATE
4-14-00

SCALE: 1" = .4'

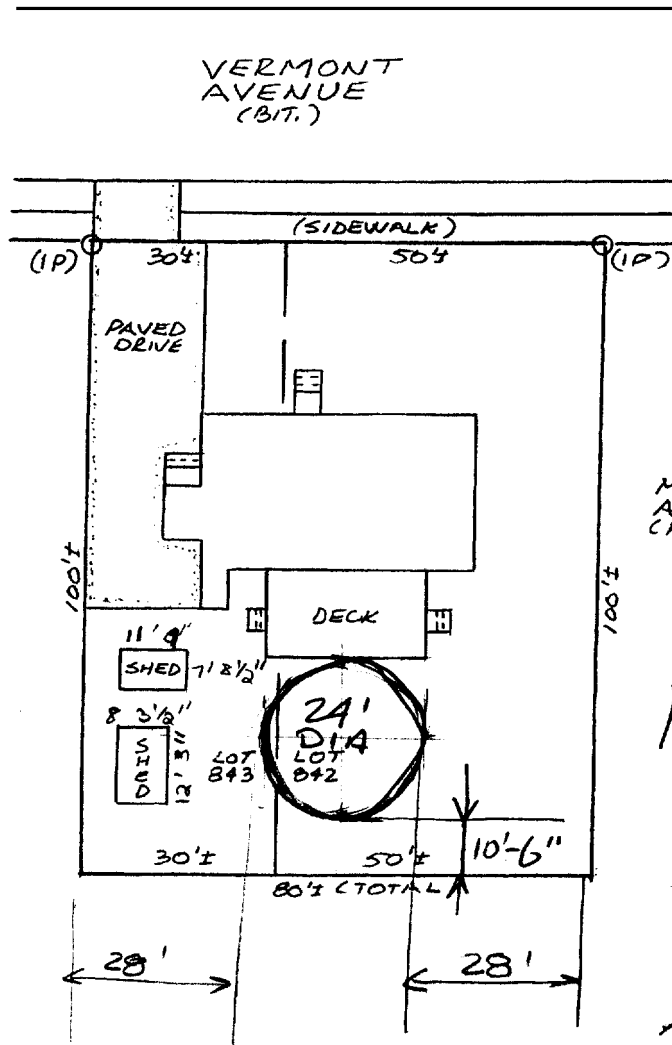
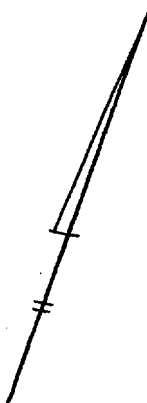

DWELLING IS A 1 STORY
 WOOD HOUSE ON A
 CONCRETE FOUNDATION

height = 52"
 of
 pool wall