

DISPLAY THIS CARD ON PRINCIPAL FRONTAGE OF WORK CITY OF PORTLAND

BUILDING DEPARTMENT

Please Read Application And Notes, If Any, Attached

PERMIT

Permit Number: 090601

PERMIT ISSUED

JUN 22 2009

CB 402 C001001

This is to certify that J J & K MANAGEMENT LLC on Murp

has permission to Replace existing stairs

AT 1269 WASHINGTON AVE

provided that the person or persons, firm or corporation accepting this permit shall comply with all of the provisions of the Statutes of Maine and of the Ordinances of the City of Portland regulating the construction, maintenance and use of buildings and structures, and of the application on file in this department.

Apply to Public Works for street line and grade if nature of work requires such information.

Notification of inspection must be given and written permission procured before this building or part thereof is lathed or otherwise worked-in. 24 HOURS NOTICE IS REQUIRED.

A certificate of occupancy must be procured by owner before this building or part thereof is occupied.

OTHER REQUIRED APPROVALS

- Fire Dept. _____
- Health Dept. _____
- Appeal Board _____
- Other _____
Department Name

Thomas Maffey 6/22/09
Director - Building & Inspection Services

PENALTY FOR REMOVING THIS CARD

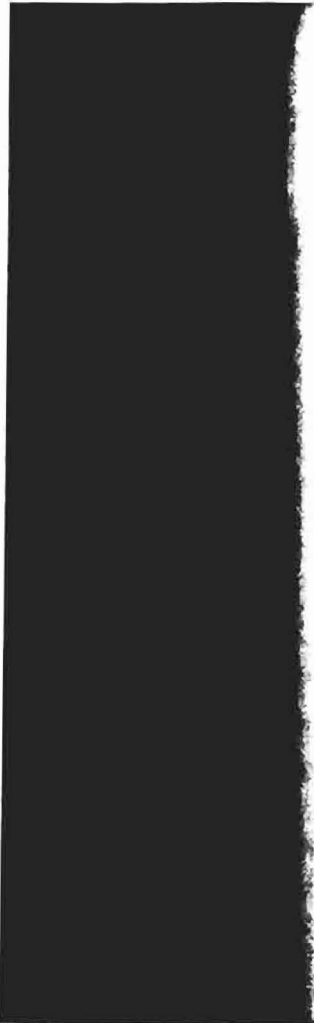

BUILDING PERMIT INSPECTION PROCEDURES

Please call 874-8703 or 874-8693 (ONLY)

to schedule your inspections as agreed upon

Permits expire in 6 months, if the project is not started or ceases for 6 months.

The Owner or their designee is required to notify the inspections office for the following inspections and provide adequate notice. Notice must be called in 48-72 hours in advance in order to schedule an inspection:

By initializing at each inspection time, you are agreeing that you understand the inspection procedure and additional fees from a "Stop Work Order" and "Stop Work Order Release" will be incurred if the procedure is not followed as stated below.

A Pre-construction Meeting will take place upon receipt of your building permit.

~~Final~~ Building Location Inspection: Prior to pouring concrete or setting precast piers

Final inspection required at completion of work.

Certificate of Occupancy is not required for certain projects. Your inspector can advise you if your project requires a Certificate of Occupancy. All projects DO require a final inspection.

If any of the inspections do not occur, the project cannot go on to the next phase, REGARDLESS OF THE NOTICE OR CIRCUMSTANCES.

CERIFICATE OF OCCUPANICES MUST BE ISSUED AND PAID FOR, BEFORE THE SPACE MAY BE OCCUPIED.

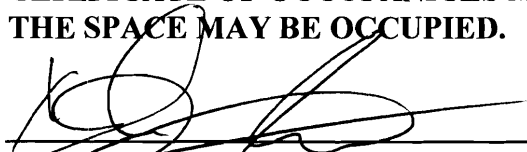

Signature of Applicant/Designee

6/22/09

Date



Signature of Inspections Official

6/22/09

Date

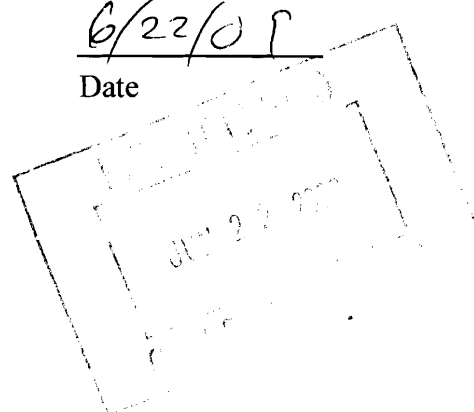

City of Portland, Maine - Building or Use Permit

389 Congress Street, 04101 Tel: (207) 874-8703, Fax: (207) 874-8716

Permit No: 09-0601	Date Applied For: 06/11/2009	CBL: 402 C001001
------------------------------	--	----------------------------

Location of Construction: 1269 WASHINGTON AVE	Owner Name: J J & K MANAGEMENT LLC	Owner Address: 252 US ROUTE ONE	Phone:
Business Name:	Contractor Name: John Murphy	Contractor Address: 252 Route One Scarborough	Phone (207) 329-2047
Lessee/Buyer's Name	Phone:	Permit Type: Additions - Duplex	

Proposed Use: 2 Family - Replace existing stairs	Proposed Project Description: Replace existing stairs
--	---

Dept: Zoning	Status: Approved with Conditions	Reviewer: Ann Machado	Approval Date: 06/12/2009
Note: Stairs are being rotated but footprint is the same or less.			Ok to Issue: <input checked="" type="checkbox"/>
1) This property shall remain a two family dwelling. Any change of use shall require a separate permit application for review and approval.			
2) This permit is being approved on the basis of plans submitted. Any deviations shall require a separate approval before starting that work.			
Dept: Building	Status: Approved with Conditions	Reviewer: Tom Markley	Approval Date: 06/22/2009
Note:			Ok to Issue: <input checked="" type="checkbox"/>
1) Application approval based upon information provided by applicant. Any deviation from approved plans requires separate review and approval prior to work.			

Comments: 6/22/2009-tm: called Jon Murphy and left a message that I needed more info on building plans.

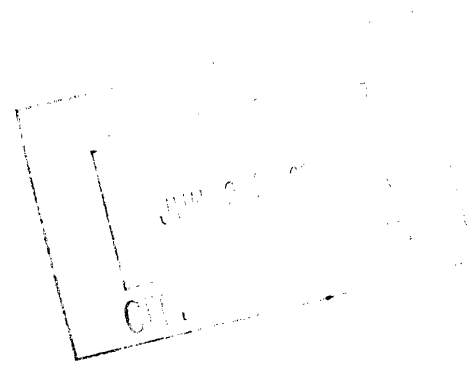

City of Portland, Maine - Building or Use Permit Application

389 Congress Street, 04101 Tel: (207) 874-8703, Fax: (207) 874-8716

Permit No: 09-0601	Issue Date:	CBL: 402 C001001
-----------------------	-------------	---------------------

Location of Construction: 1269 WASHINGTON AVE	Owner Name: J J & K MANAGEMENT LLC	Owner Address: 252 US ROUTE ONE	Phone:
Business Name:	Contractor Name: John Murphy	Contractor Address: 252 Route One Scarborough	Phone 2073292047
Lessee/Buyer's Name	Phone:	Permit Type: Additions - Duplex	Zone: R-3

Past Use: 2 Family	Proposed Use: 2 Family - Replace existing stairs	Permit Fee: \$30.00	Cost of Work: \$300.00	CEO District: 4
Proposed Project Description: Replace existing stairs		FIRE DEPT: <input type="checkbox"/> Approved <input type="checkbox"/> Denied	INSPECTION: Use Group: R3 Type: SB IRC 2003	
		Signature: <i>Jm 6/22/09</i>		
PEDESTRIAN ACTIVITIES DISTRICT (P.A.D.)				
Action: <input type="checkbox"/> Approved <input type="checkbox"/> Approved w/Conditions <input type="checkbox"/> Denied				
Signature: _____ Date: _____				

Permit Taken By: Ldobson	Date Applied For: 06/11/2009	Zoning Approval		
-----------------------------	---------------------------------	------------------------	--	--

- This permit application does not preclude the Applicant(s) from meeting applicable State and Federal Rules.
- Building permits do not include plumbing, septic or electrical work.
- Building permits are void if work is not started within six (6) months of the date of issuance. False information may invalidate a building permit and stop all work..

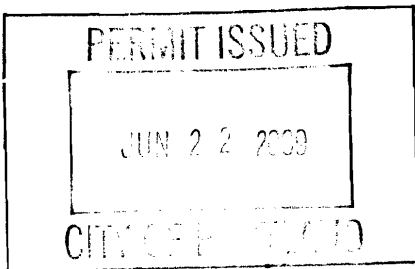

Special Zone or Reviews	Zoning Appeal	Historic Preservation
<input type="checkbox"/> Shoreland	<input type="checkbox"/> Variance	<input checked="" type="checkbox"/> Not in District or Landmark
<input type="checkbox"/> Wetland	<input type="checkbox"/> Miscellaneous	<input type="checkbox"/> Does Not Require Review
<input type="checkbox"/> Flood Zone	<input type="checkbox"/> Conditional Use	<input type="checkbox"/> Requires Review
<input type="checkbox"/> Subdivision	<input type="checkbox"/> Interpretation	<input type="checkbox"/> Approved
<input type="checkbox"/> Site Plan	<input type="checkbox"/> Approved	<input type="checkbox"/> Approved w/Conditions
Maj <input type="checkbox"/> Minor <input type="checkbox"/> MM <input type="checkbox"/>	<input type="checkbox"/> Denied	<input type="checkbox"/> Denied
Date: <i>6/12/09</i>	Date: _____	Date: <i>[Signature]</i>

CERTIFICATION

I hereby certify that I am the owner of record of the named property, or that the proposed work is authorized by the owner of record and that I have been authorized by the owner to make this application as his authorized agent and I agree to conform to all applicable laws of this jurisdiction. In addition, if a permit for work described in the application is issued, I certify that the code official's authorized representative shall have the authority to enter all areas covered by such permit at any reasonable hour to enforce the provision of the code(s) applicable to such permit.

SIGNATURE OF APPLICANT	ADDRESS	DATE	PHONE
RESPONSIBLE PERSON IN CHARGE OF WORK, TITLE		DATE	PHONE

City of Portland, Maine - Building or Use Permit

389 Congress Street, 04101 Tel: (207) 874-8703, Fax: (207) 874-8716

Permit No: 09-0601	Date Applied For: 06/11/2009	CBL: 402 C001001
------------------------------	--	----------------------------

Location of Construction: 1269 WASHINGTON AVE	Owner Name: J J & K MANAGEMENT LLC	Owner Address: 252 US ROUTE ONE	Phone:
Business Name:	Contractor Name: John Murphy	Contractor Address: 252 Route One Scarborough	Phone (207) 329-2047
Lessee/Buyer's Name	Phone:	Permit Type: Additions - Duplex	

Proposed Use: 2 Family - Replace existing stairs	Proposed Project Description: Replace existing stairs
--	---

Dept: Zoning	Status: Approved with Conditions	Reviewer: Ann Machado	Approval Date: 06/12/2009
Note: Stairs are being rotated but footprint is the same or less.			Ok to Issue: <input checked="" type="checkbox"/>
1) This property shall remain a two family dwelling. Any change of use shall require a separate permit application for review and approval.			
2) This permit is being approved on the basis of plans submitted. Any deviations shall require a separate approval before starting that work.			
Dept: Building	Status: Approved with Conditions	Reviewer: Tom Markley	Approval Date: 06/22/2009
Note:			Ok to Issue: <input checked="" type="checkbox"/>
1) Application approval based upon information provided by applicant. Any deviation from approved plans requires separate review and approval prior to work.			

Comments: 6/22/2009-tm: called Jon Murphy and left a message that I needed more info on building plans.



General Building Permit Application

If you or the property owner owes real estate or personal property taxes or user charges on any property within the City, payment arrangements must be made before permits of any kind are accepted.

Location/Address of Construction: <u>1269 Washington Ave</u>		
Total Square Footage of Proposed Structure/Area	Square Footage of Lot	Number of Stories
Tax Assessor's Chart, Block & Lot Chart# Block# Lot# <u>402 C001 001</u>	Applicant "must be owner, Lessee or Buyer" Name <u>JOHN MURPHY</u> Address <u>252 Rte. 1</u> City, State & Zip <u>Scarborough, ME 04074</u>	Telephone: <u>883-4327</u>
Lessee/DBA (If Applicable)	Owner (if different from Applicant) Name Address City, State & Zip	Cost Of Work: \$ <u>300-</u> C of O Fee: \$ _____ Total Fee: \$ <u>30</u>

Current legal use (i.e. single family) 2 units Number of Residential Units 2
 If vacant, what was the previous use? _____
 Proposed Specific use: _____
 Is property part of a subdivision? _____ If yes, please name _____
 Project description: Building PT STAIRS TO REPLACE OLD STAIRS

Contractor's name: JOHN MURPHY
 Address: SAME AS ABOVE
 City, State & Zip _____ Telephone: _____
 Who should we contact when the permit is ready: _____ Telephone: _____
 Mailing address: _____

Please submit all of the information outlined on the applicable Checklist. Failure to do so will result in the automatic denial of your permit.

In order to be sure the City fully understands the full scope of the project, the Planning and Development Department may request additional information prior to the issuance of a permit. For further information or to download copies of this form and other applications visit the Inspections Division on-line at www.portlandmaine.gov, or stop by the Inspections Division office, room 315 City Hall or call 874-8703.

I hereby certify that I am the Owner of record of the named property, or that the owner of record authorizes the proposed work and that I have been authorized by the owner to make this application as his/her authorized agent. I agree to conform to all applicable laws of this jurisdiction. In addition, if a permit for work described in this application is issued, I certify that the Code Official's authorized representative shall have the authority to enter all areas covered by this permit at any reasonable hour to enforce the provisions of the codes applicable to this permit.

Signature: [Handwritten Signature] Date: 6/11/09

This is not a permit; you may not commence ANY work until the permit is issued

1269 Washington Ave,
Portland, ME

36" x 50" = 1800 #
125 #

PERMIT DESCRIPTION

We are planning to replace the exterior stairway on an ongoing rehab project.

Stair Detail:

- 44" wide pressure treated stairs, 36" finished tread area. The total height of the stairs will be 35"
- 3 five step stringers with a 7" rise and 10" run and they will be spaced 18" apart
- Stair treads will be 5/4x6 PT with a 1/2" over hang over stringers for nosing.
- The railings will be on both right and left sides of the steps.
- The railing will be built out of PT 4x4 posts driven one foot in the ground and nailed to the stringers. It will have 2x2 PT balusters spaced 4" apart and it will have a graspable top rail.
- The top of the stringers will be screwed into a 5/4 PT plate which is lag bolted into the house with three 3" lag bolts spaced 10" apart
- The bottom of the stringers will be supported by solid patio blocks 4" thick, 8 inches wide, and 16 inches long

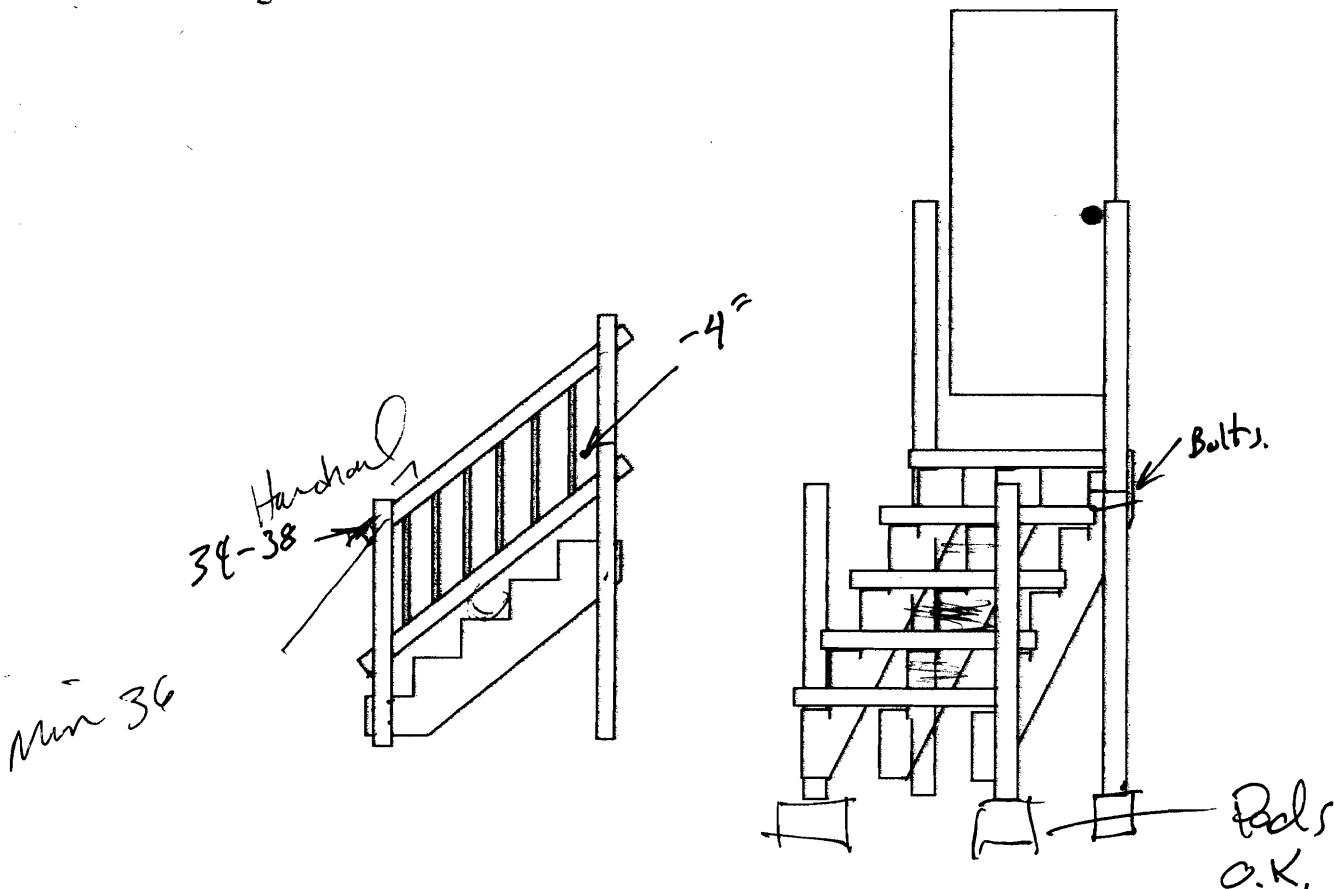

TITLE REFERENCE

DEED BOOK: 4420 PAGE: 6
PLAN BOOK: 12 PAGE: 17 LOT(S): P/O 6
PLAN NUMBER: N/A OF N/A

APPLICANT: JOHN MURPHY

ASSESSORS MAP

SCALE: 1"=30' MAP: 402 BLOCK: C PARCEL: 1

1269 WASHINGTON AVENUE, PORTLAND, ME

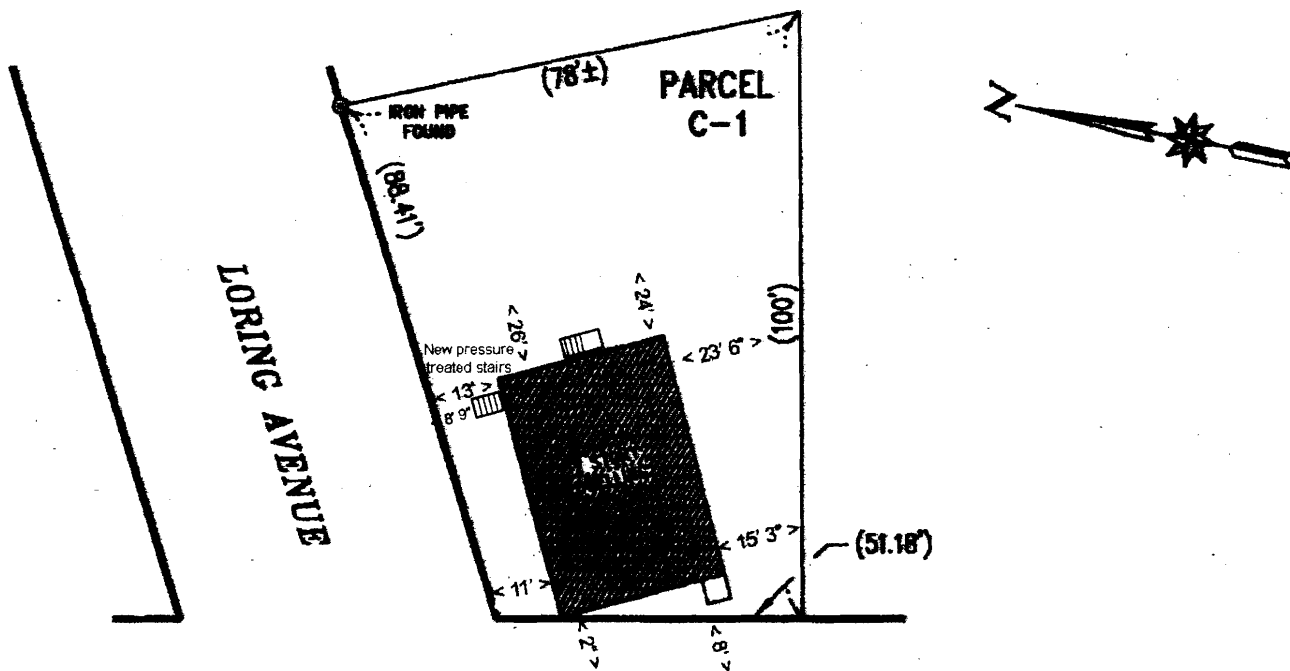

WASHINGTON AVENUE

6/24/09 - checked new stars - all
OK.
JMM



CITY OF PORTLAND, MAINE
Department of Building Inspections

Original Receipt

6-11-2009

Received from Spring Hill

Location of Work 1269 Washington Ave

Cost of Construction \$ _____ Building Fee: _____

Permit Fee \$ _____ Site Fee: _____

Certificate of Occupancy Fee: _____

Total: 30

Building (IL) _____ Plumbing (I5) _____ Electrical (I2) _____ Site Plan (U2) _____

Other _____

CBL: 402-C-1

Check #: 1335 Total Collected \$ 30

**No work is to be started until permit issued.
Please keep original receipt for your records.**

Taken by: [Signature]

WHITE - Applicant's Copy
YELLOW - Office Copy
PINK - Permit Copy