

D5 EXTERIOR COLUMN WRAP
1 1/2" = 1'-0"

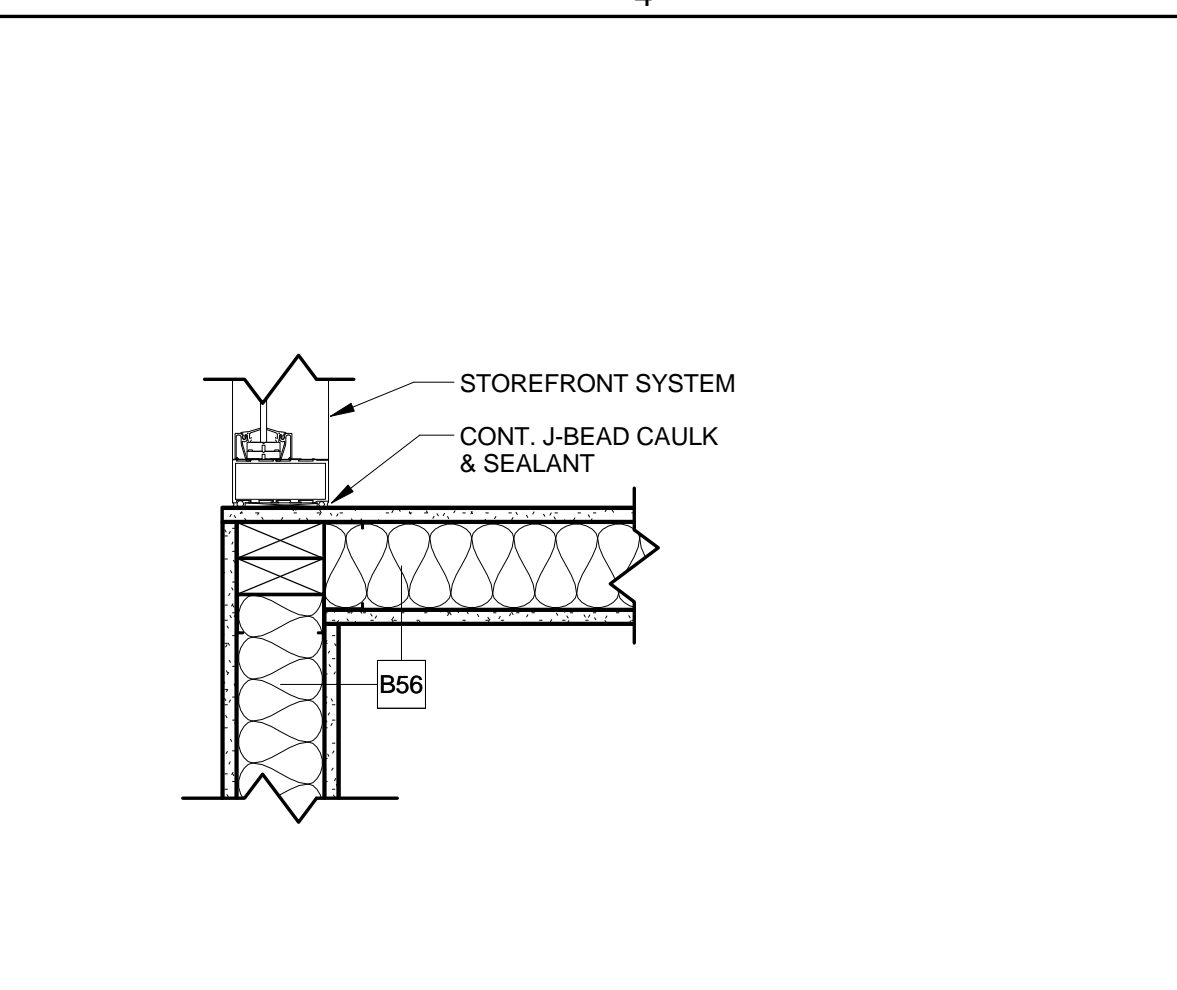

D4 PLAN DETAIL @ WALL CONNECT
1 1/2" = 1'-0"

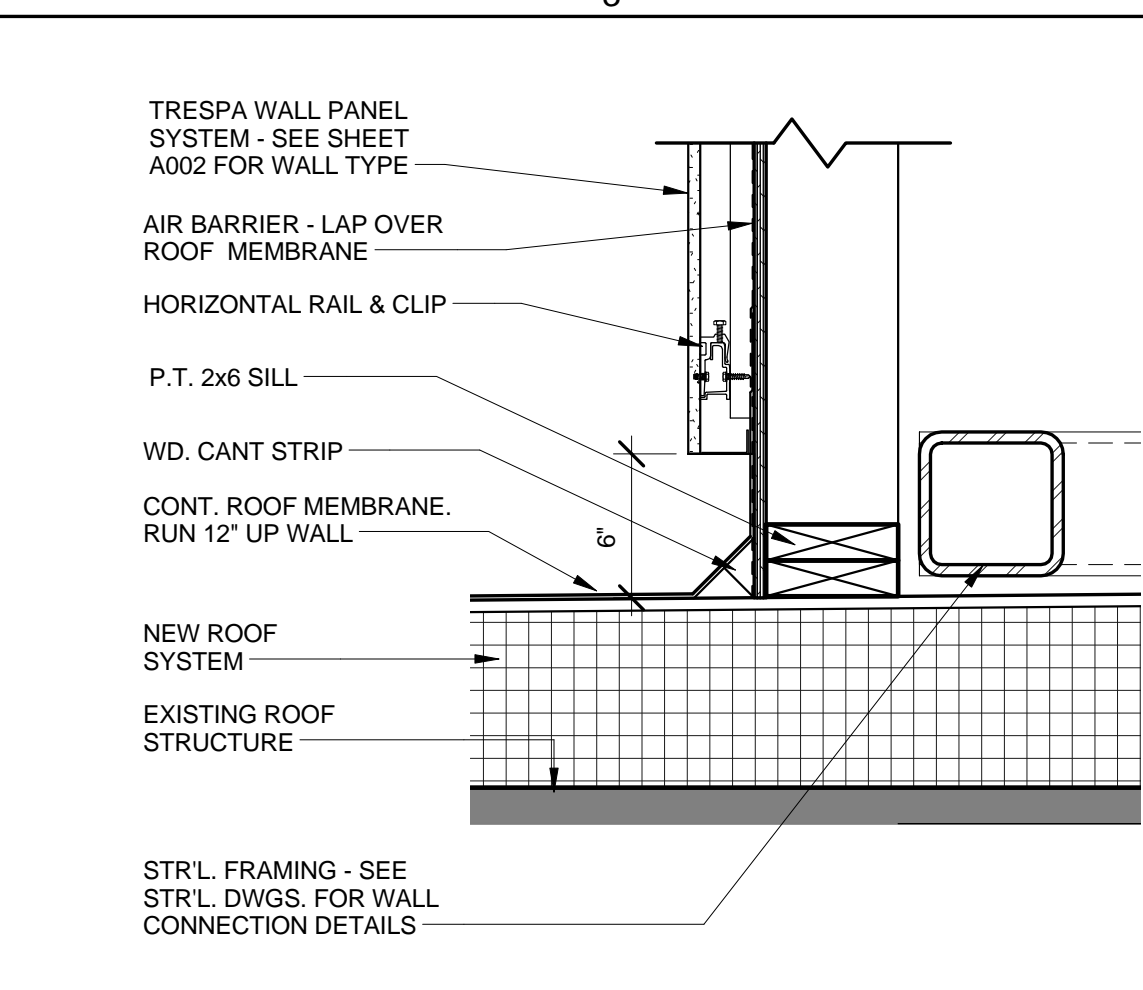

D3 DETAIL - NEW CANOPY WALL ON EXST. ROOF
1 1/2" = 1'-0"

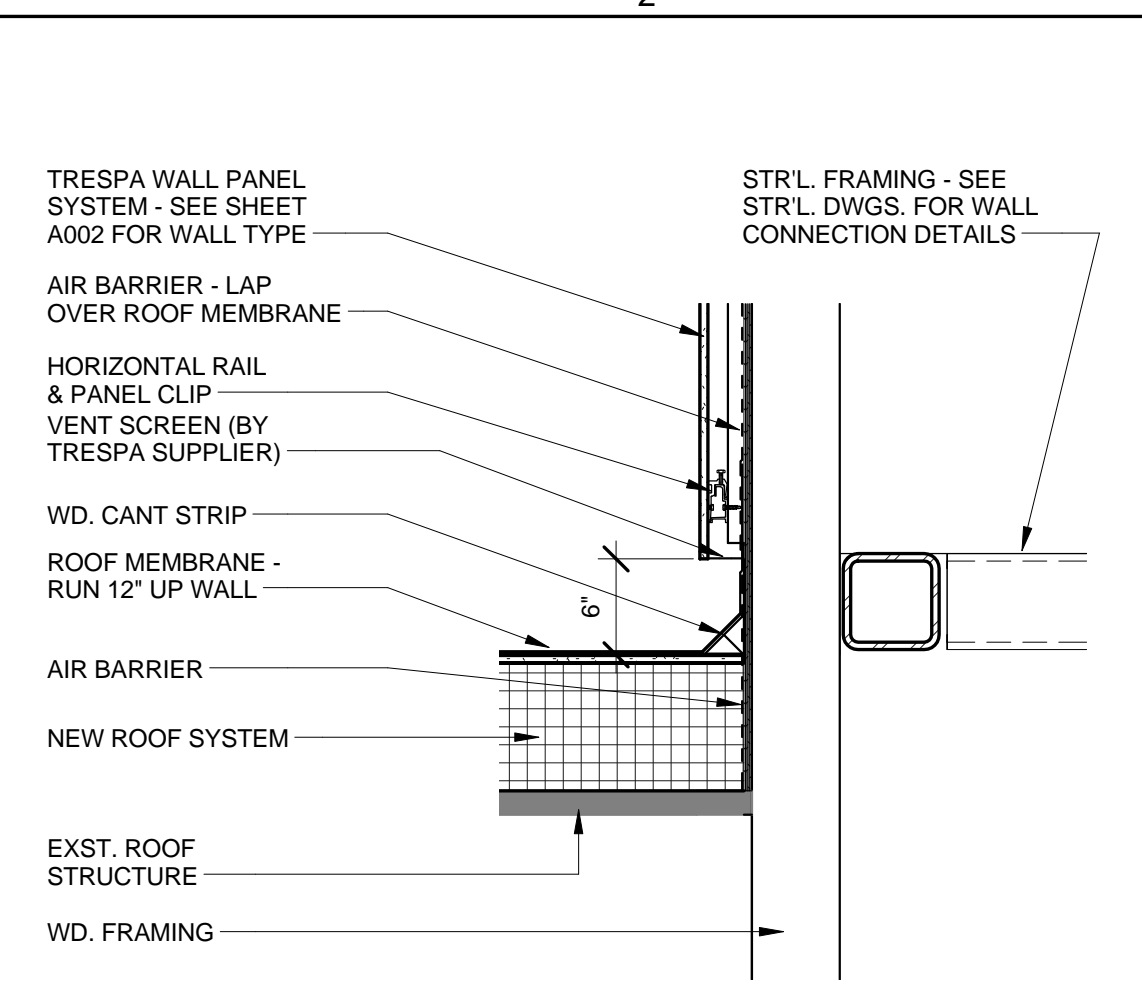

D2 CANOPY WALL - ROOF INTERSECTION
1" = 1'-0"

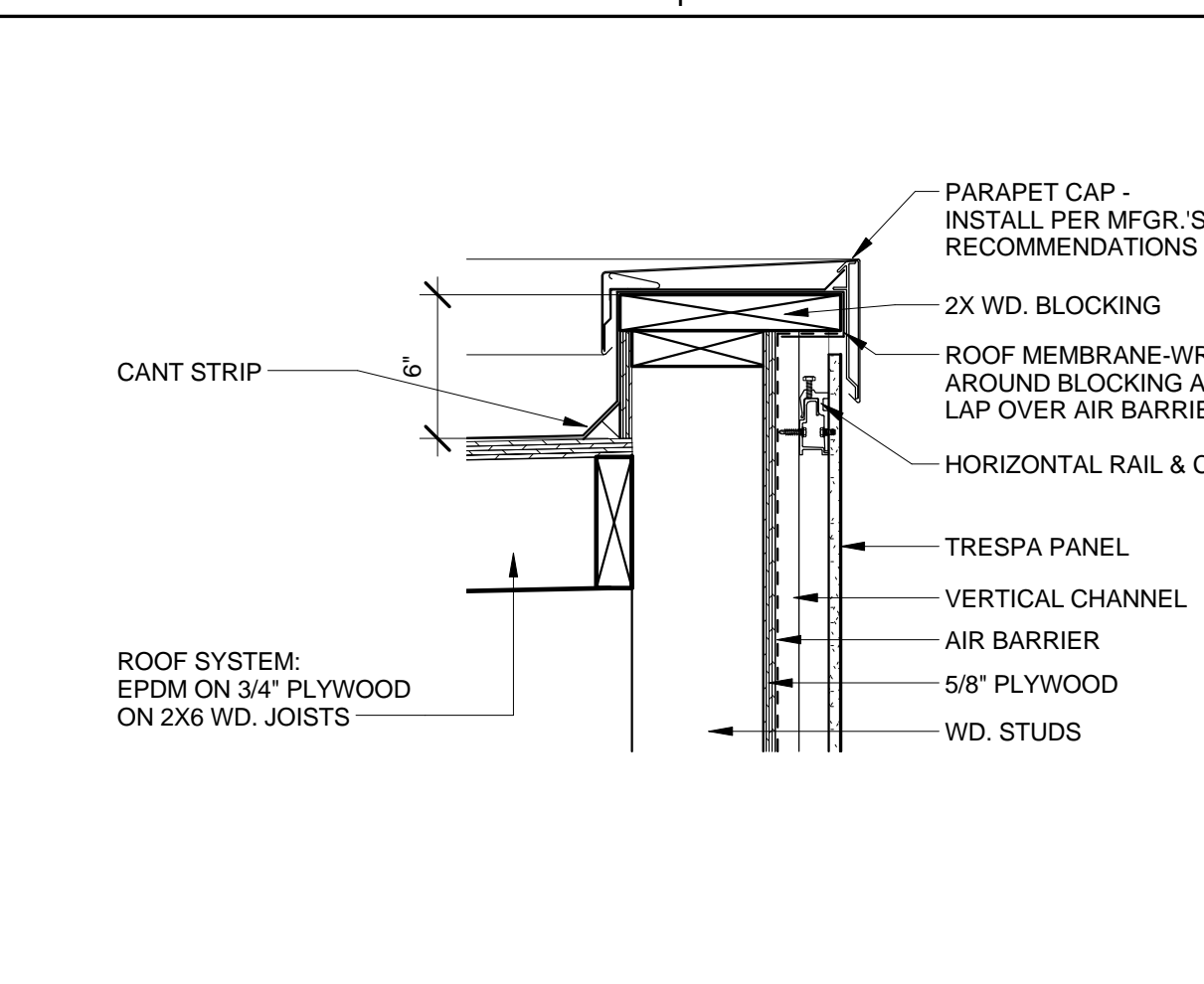

D1 DETAIL - PARAPET @ ENTRY CANOPY
1 1/2" = 1'-0"

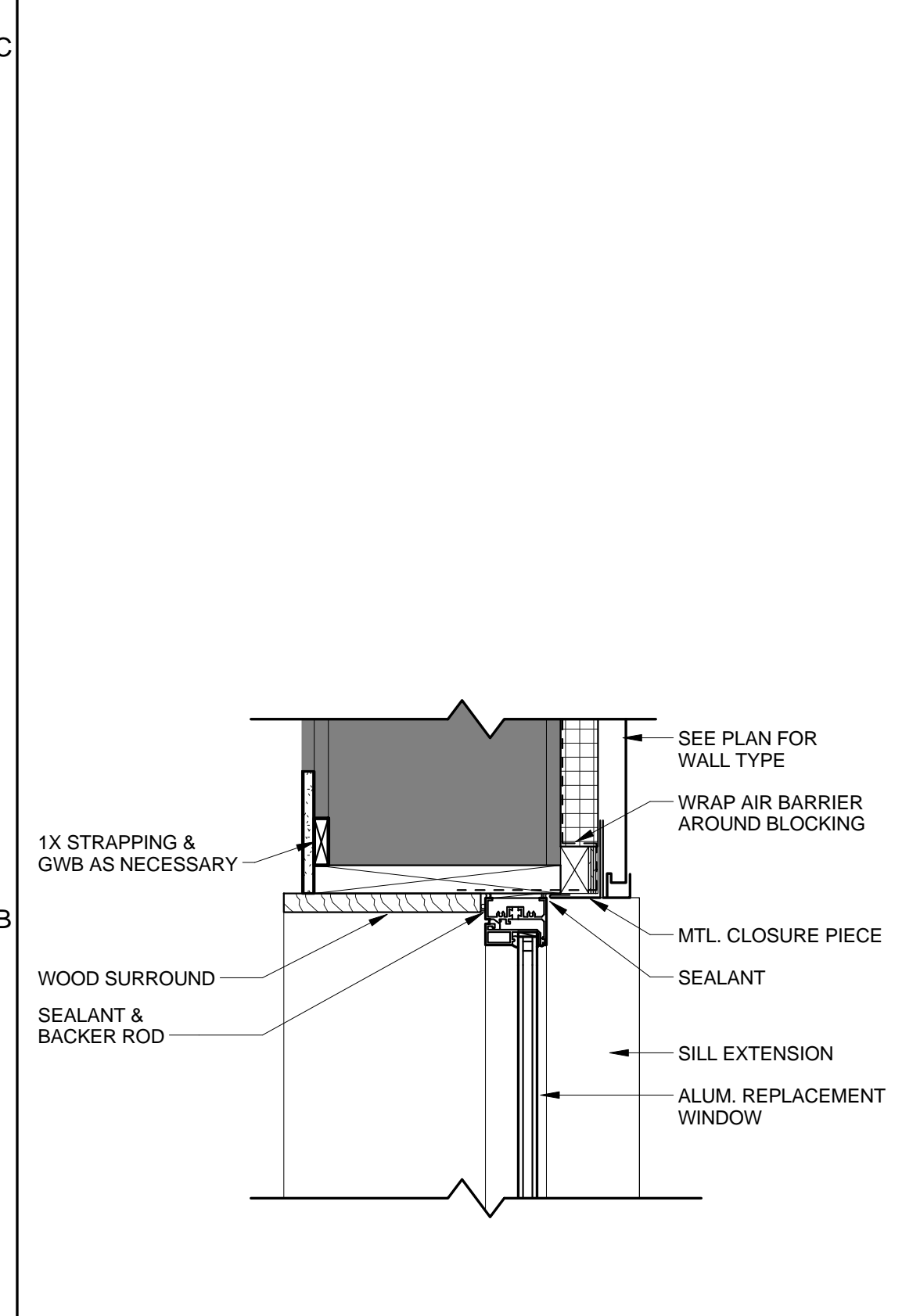

B5 JAMB @ REPLACEMENT WINDOW
1 1/2" = 1'-0"

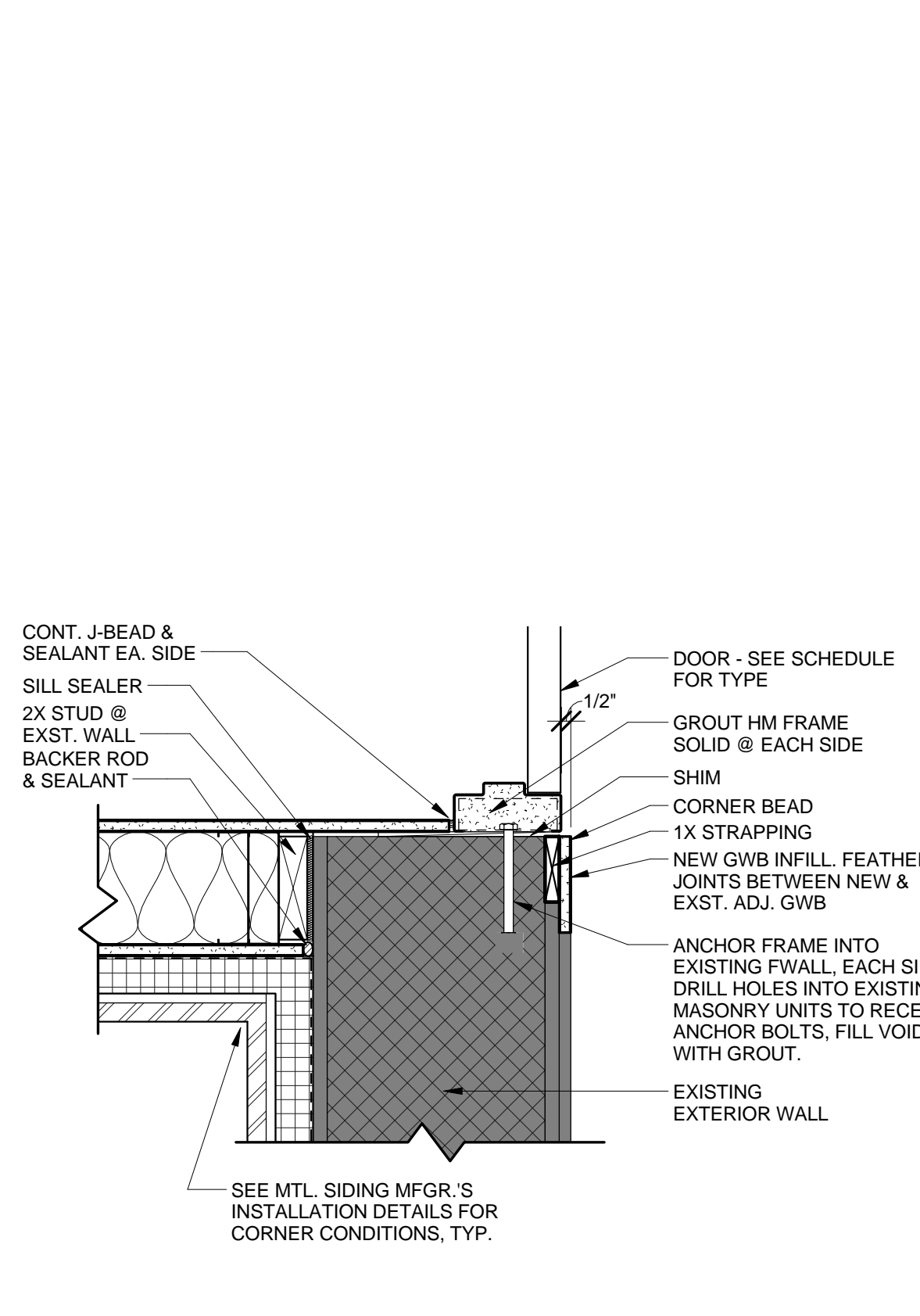

B4 PLAN DETAIL - DOOR JAMB @ ATM
1 1/2" = 1'-0"

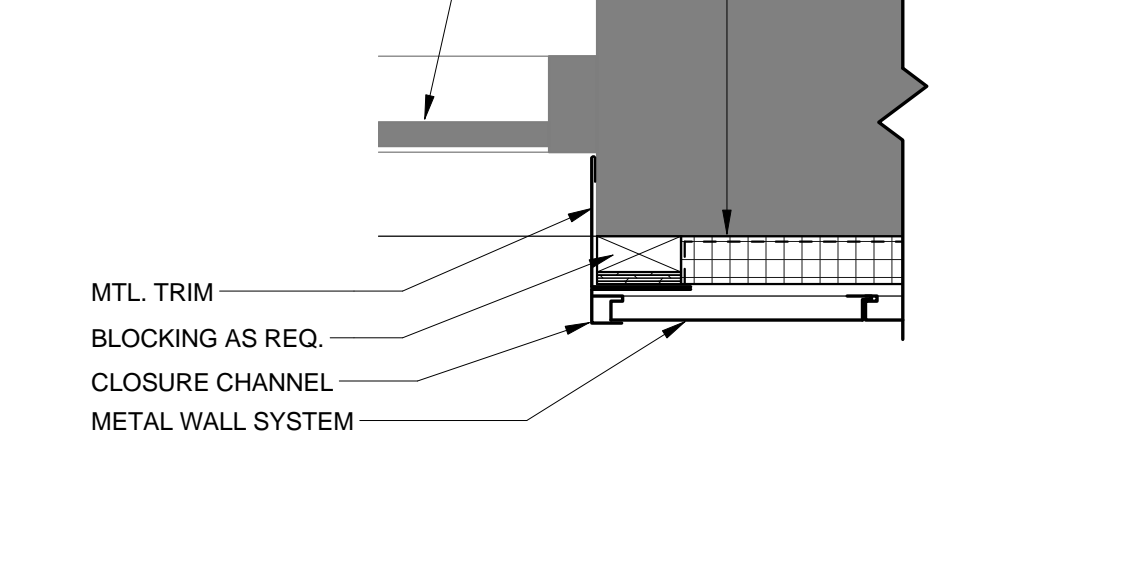

C3 DETAIL - MTL. SIDING RETURN - TYP.
1 1/2" = 1'-0"

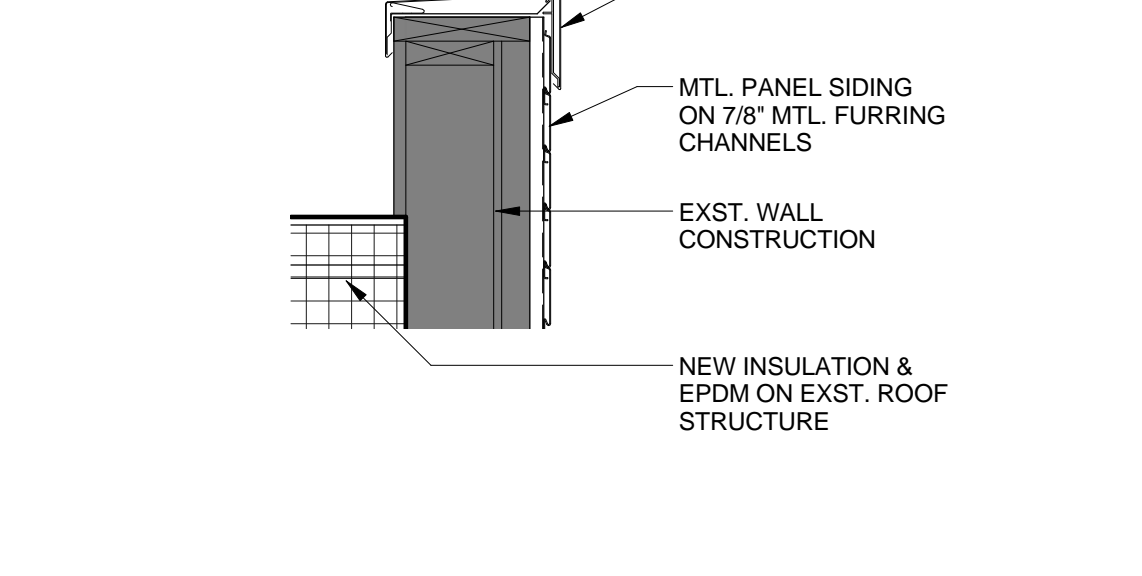

C2 PARAPET @ EXISTING CANOPY
1" = 1'-0"

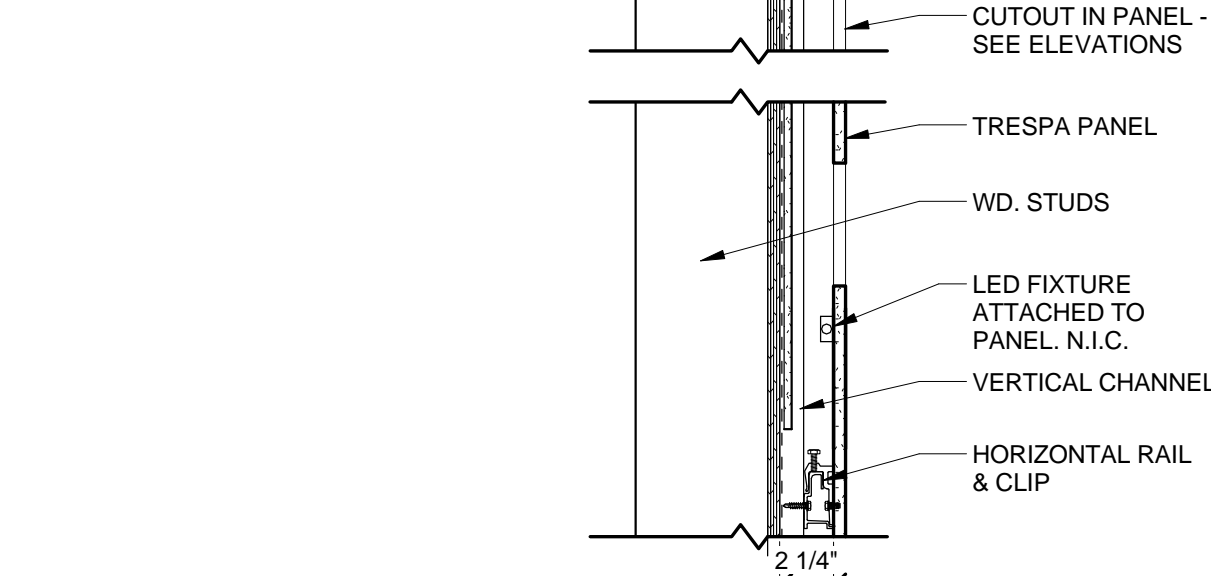

C1 DETAIL @ CANOPY CUTOUT
1 1/2" = 1'-0"

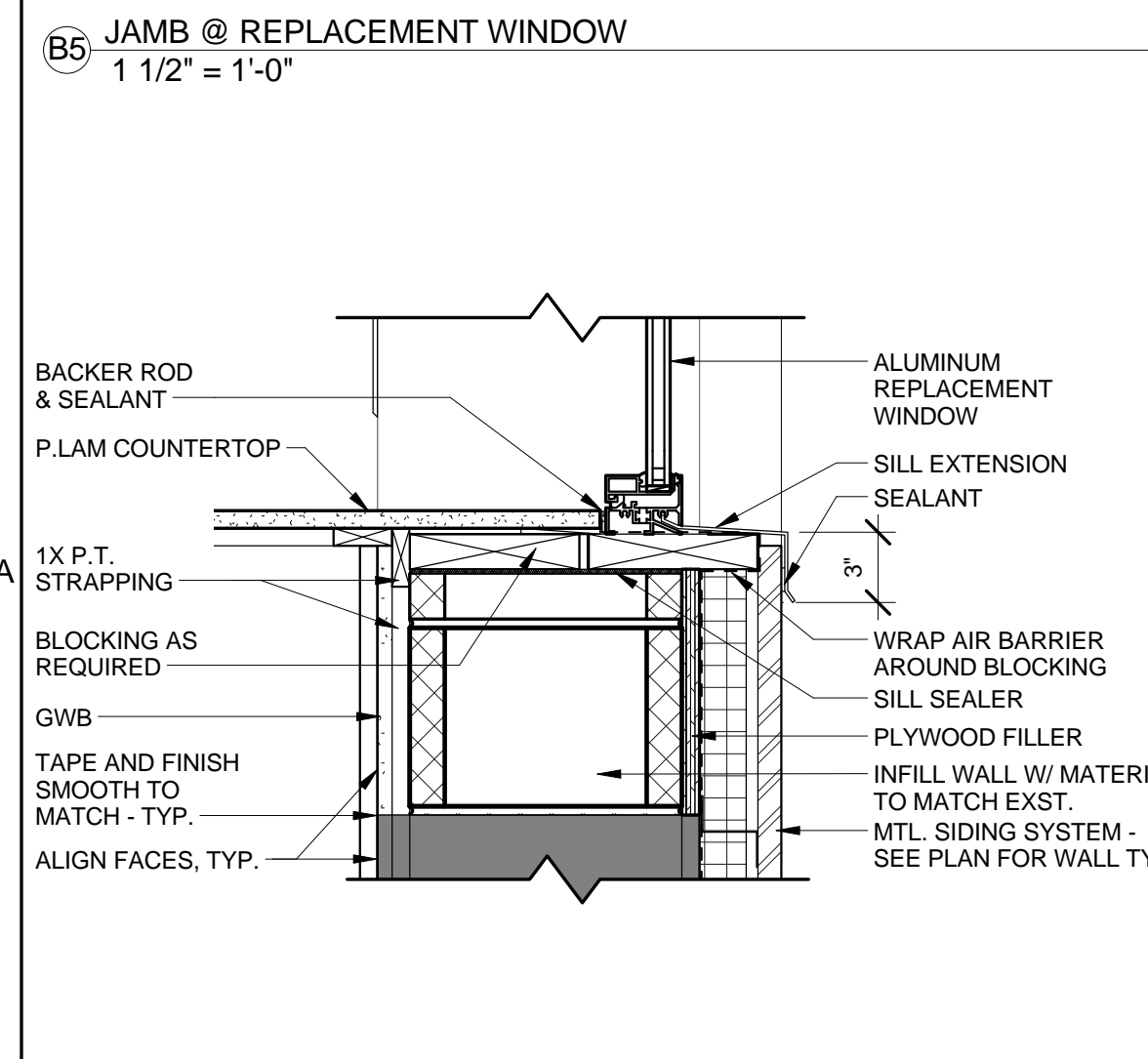

A5 DETAIL - REPLACEMENT WINDOW SILL
1 1/2" = 1'-0"

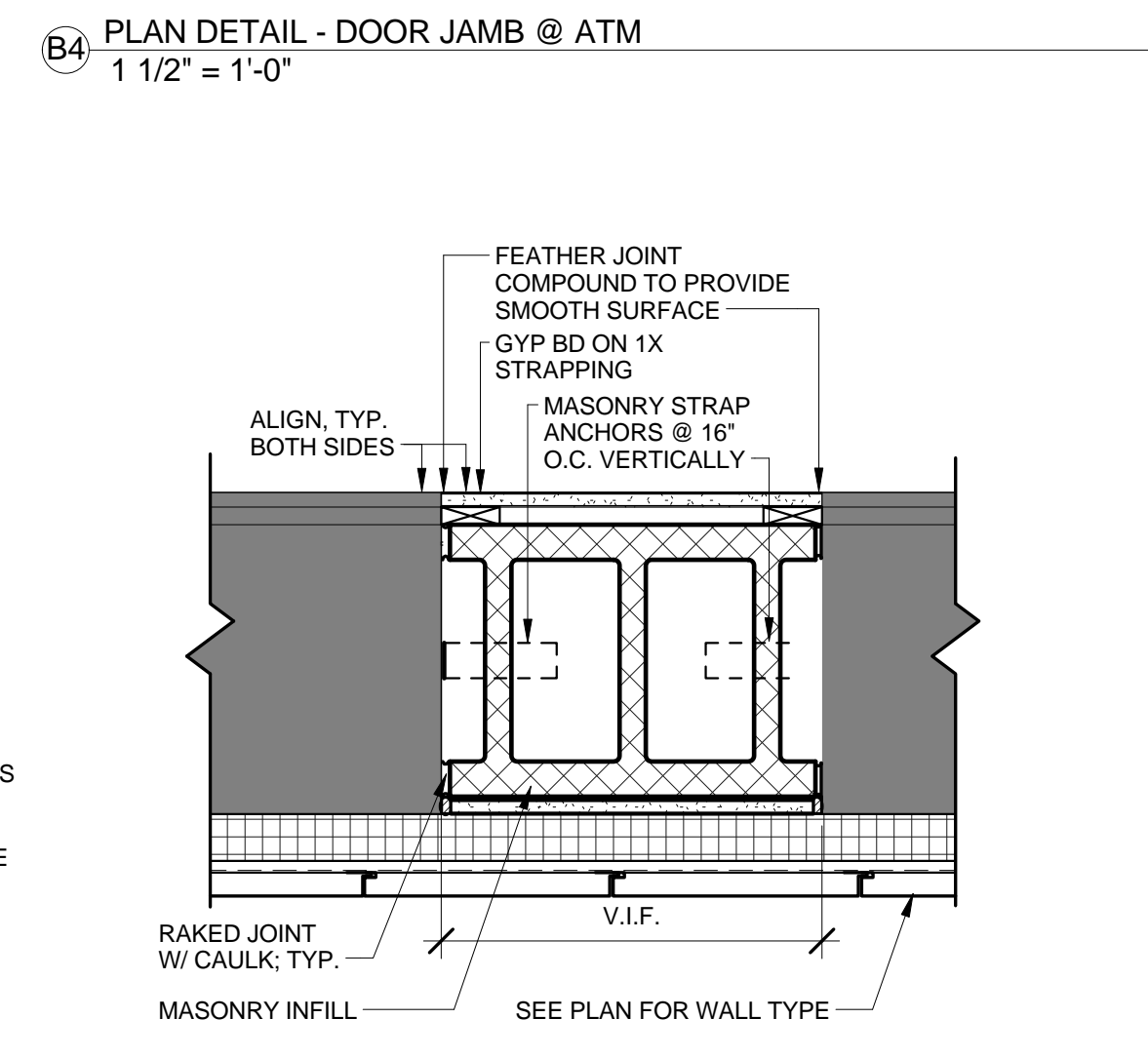

A4 PLAN DETAIL @ EXT. WALL INFILL
1 1/2" = 1'-0"

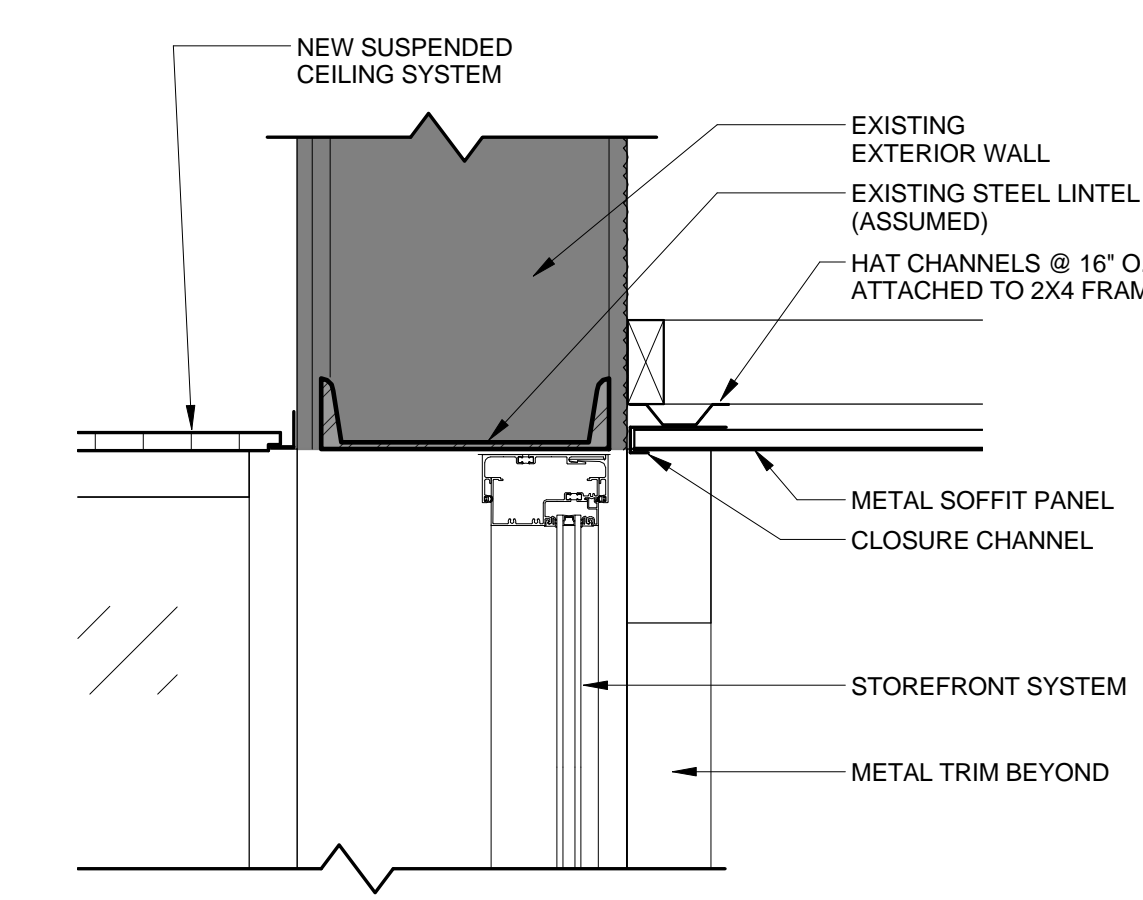

B3 SECTION DETAIL - HEAD @ EXT. STOREFRONT
1 1/2" = 1'-0"

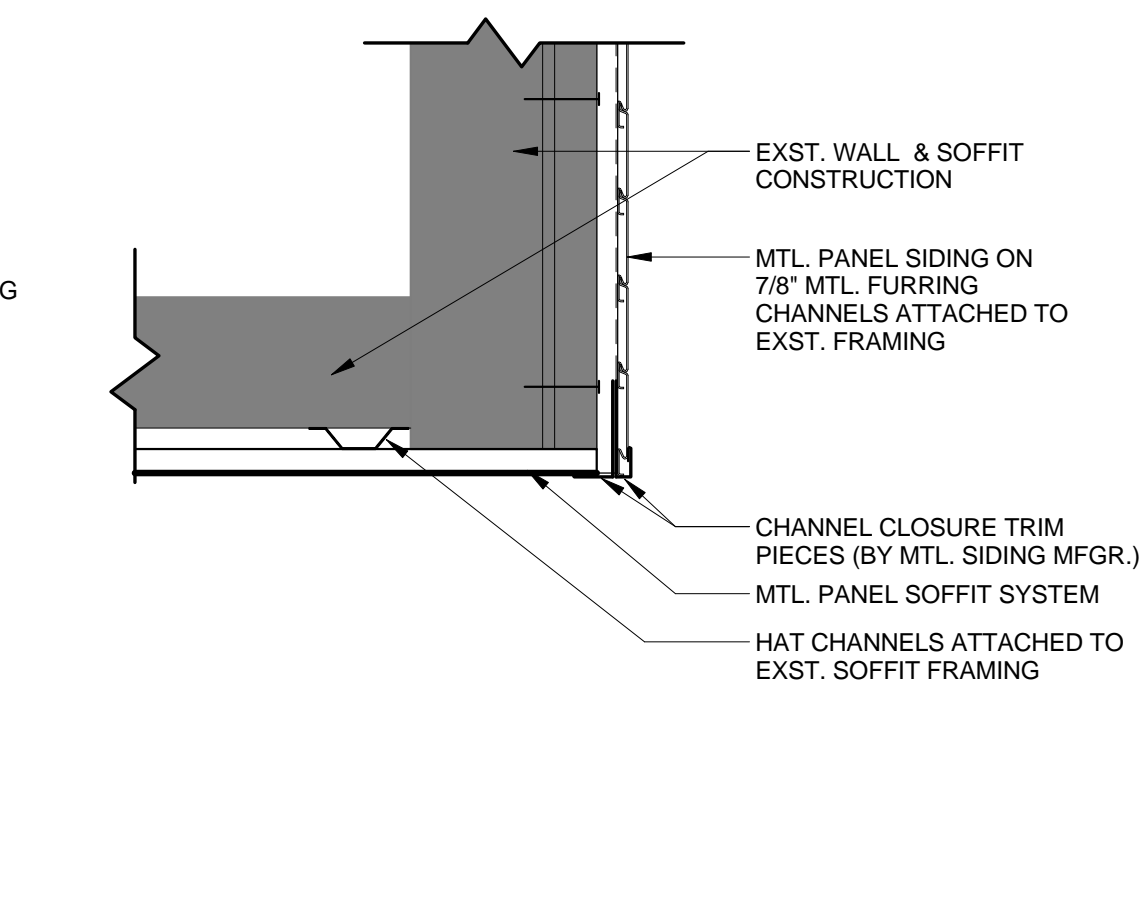

B2 NEW SOFFIT @ EXISTING CANOPY
1 1/2" = 1'-0"

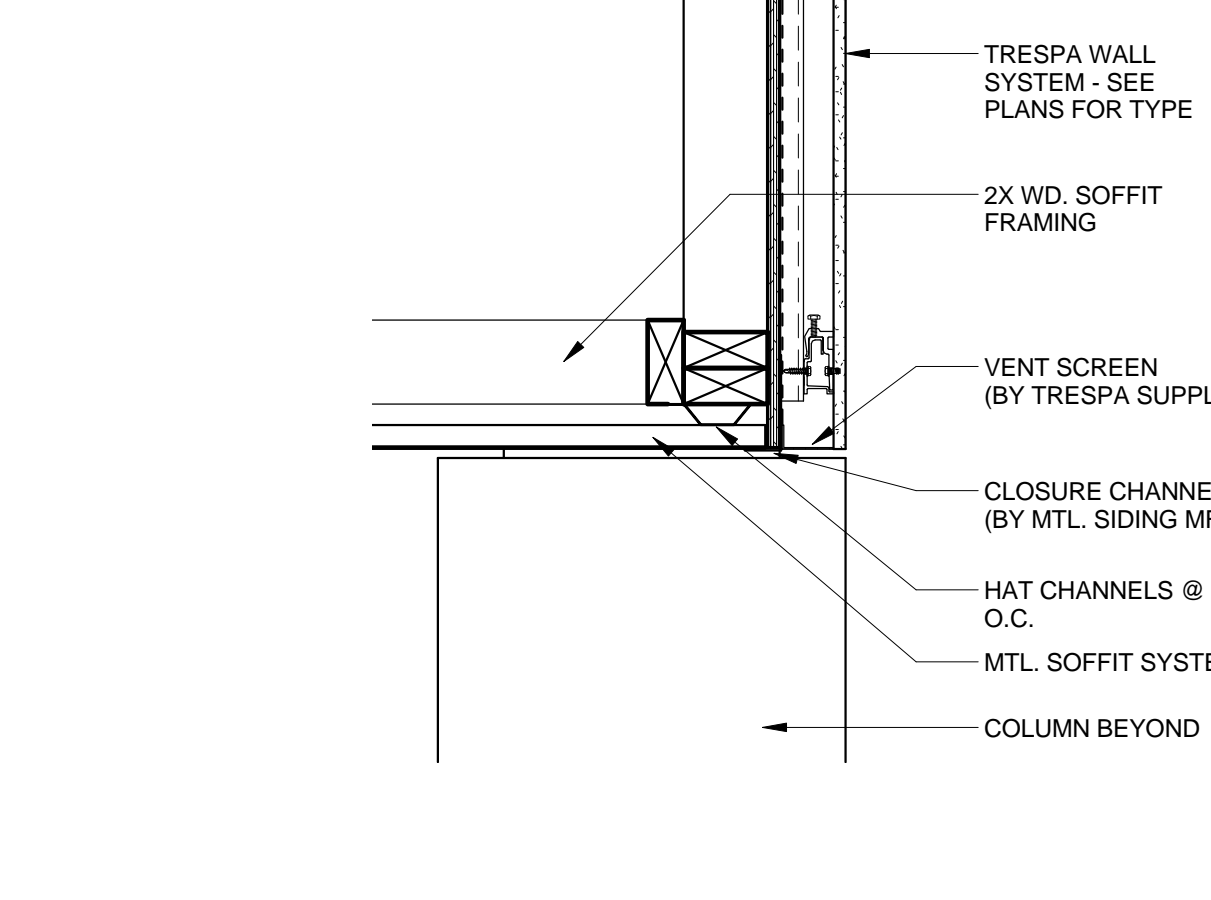

B1 DETAIL - SOFFIT @ ENTRY CANOPY
1 1/2" = 1'-0"

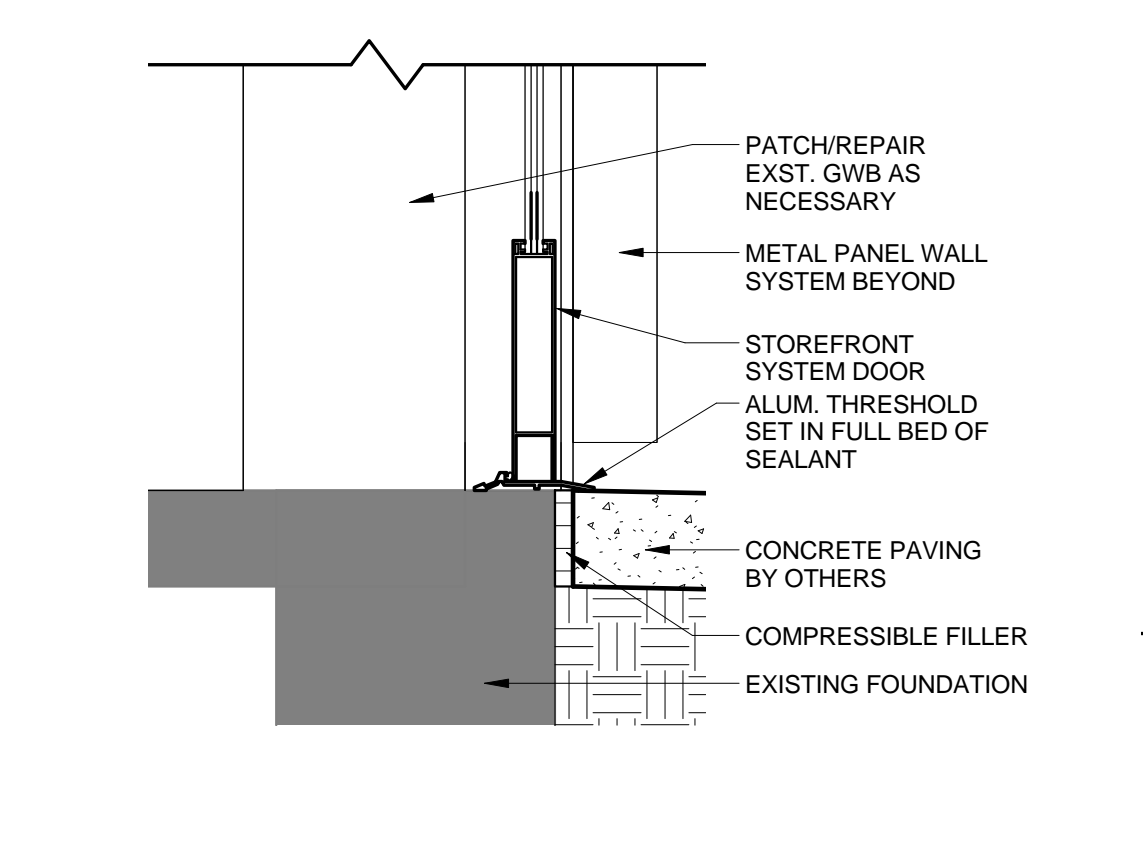

A3 DETAIL - SILL @ EXT. STOREFRONT ENTRY
1 1/2" = 1'-0"

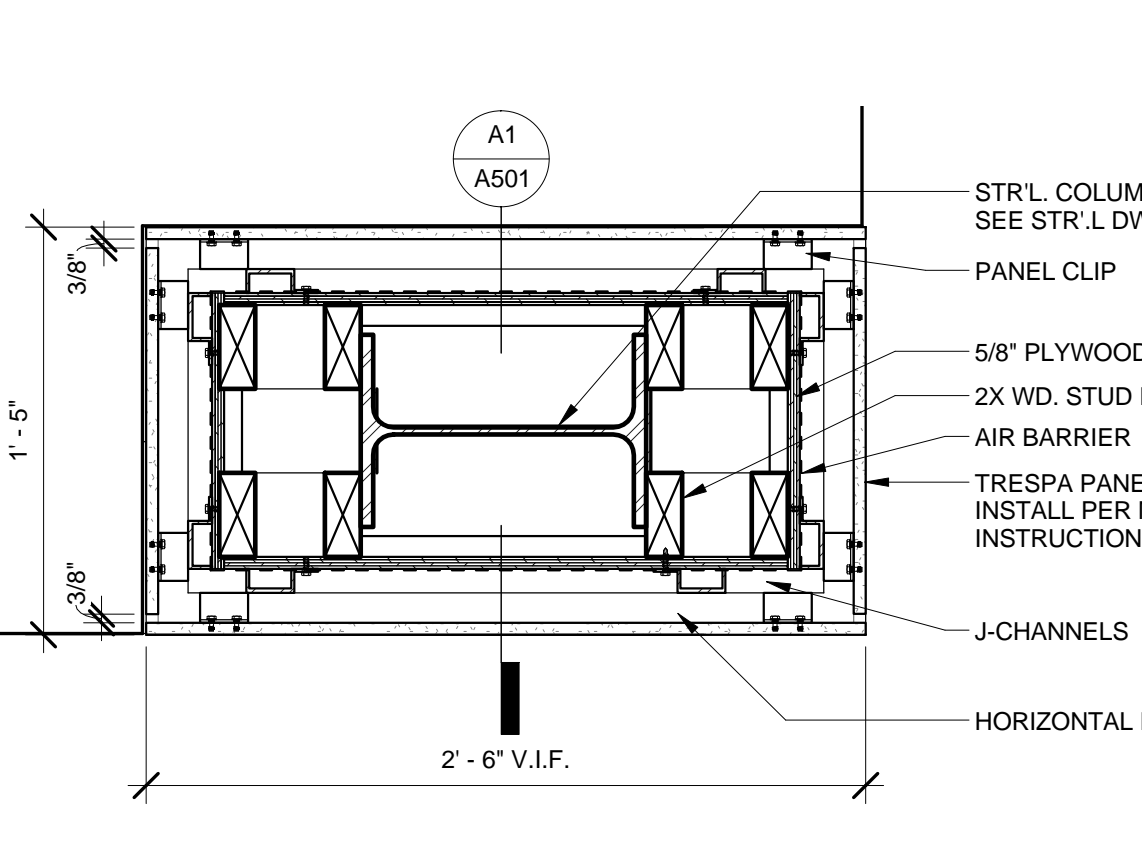

A2 PLAN DETAIL - COLUMN @ ENTRY
1 1/2" = 1'-0"

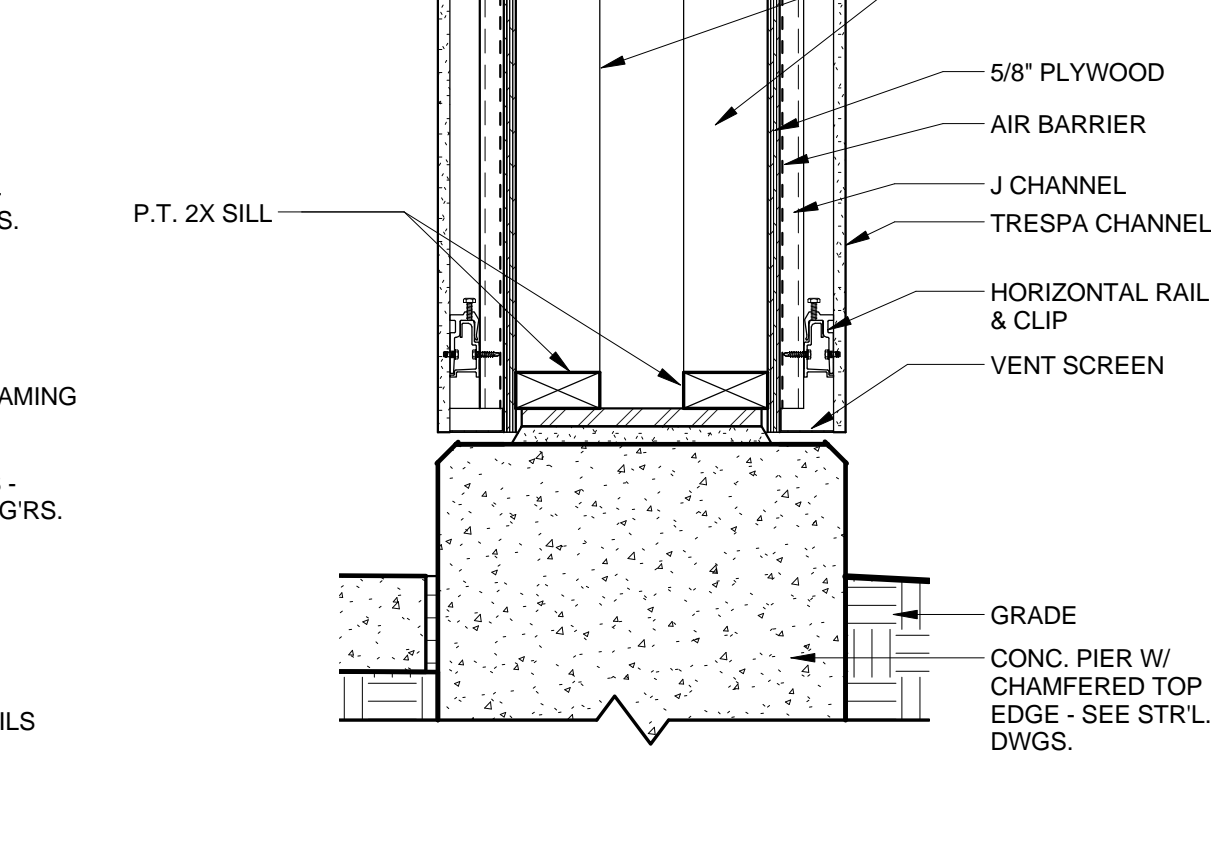

A1 SECTION - COLUMN @ ENTRY
1 1/2" = 1'-0"



49 DARTMOUTH STREET
PORTLAND, MAINE 04101
207-775-1059
www.pdtarchs.com

COPYRIGHT
PDT Architects
Reuse or reproduction of the contents of this document is not permitted without written permission of PDT Architects.

CUMBERLAND COUNTY FEDERAL CREDIT UNION
1345 Washington Avenue, Portland, ME

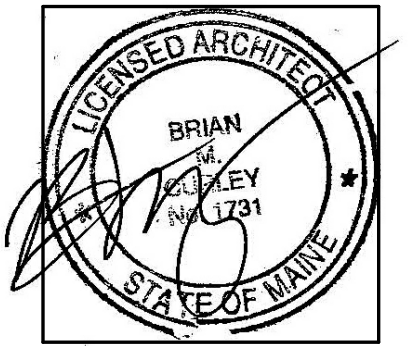

JOB NO.
12044

DRWN. Author
CHECK Checker

SCALE:
As indicated

ISSUE
30 August, 2013

TITLE
DETAILS

SHEET
A501