

NOTIFICATION APPLIANCE CIRCUIT VOLTAGE DROPS						
LL Bean Cheshire Building Portland, Maine						
PANEL	CIRCUIT	LENGTH	CURRENT DRAW	VOLTAGE DROP	VOLTAGE LOSS	END VOLTAGE
FCPS	NAC 1	344 FT	1.892A	3.29VDC	13.71%	20.71VDC
FCPS	NAC 2	304 FT	1.249A	1.92VDC	8.00%	22.08VDC

Calculated Using #14 AWG Wire @ Maximum Distance/Draw

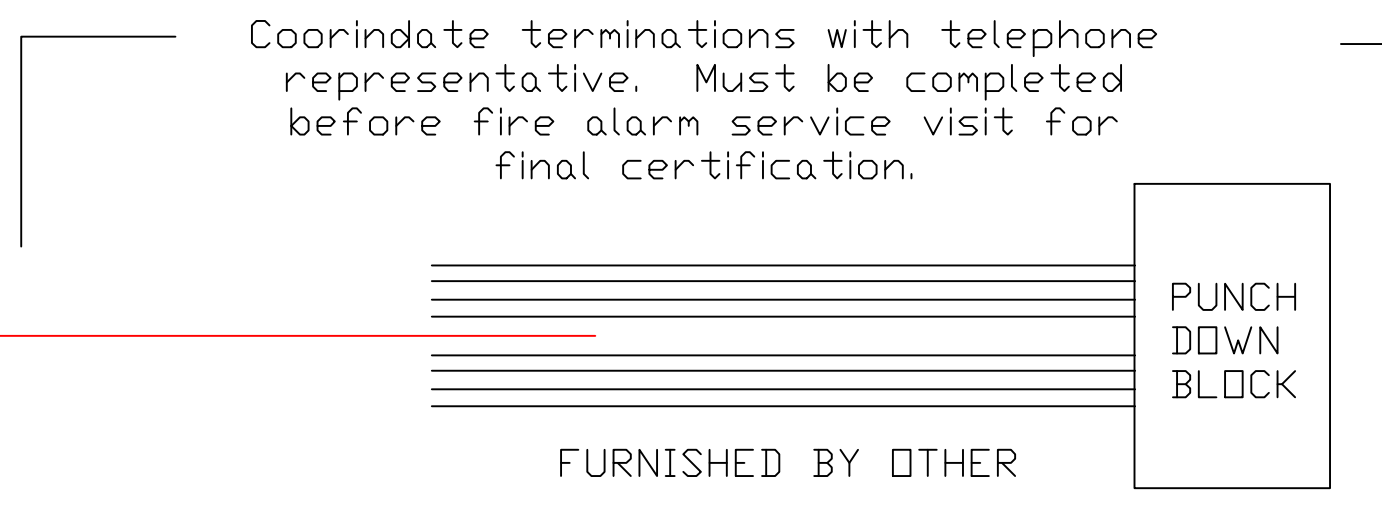
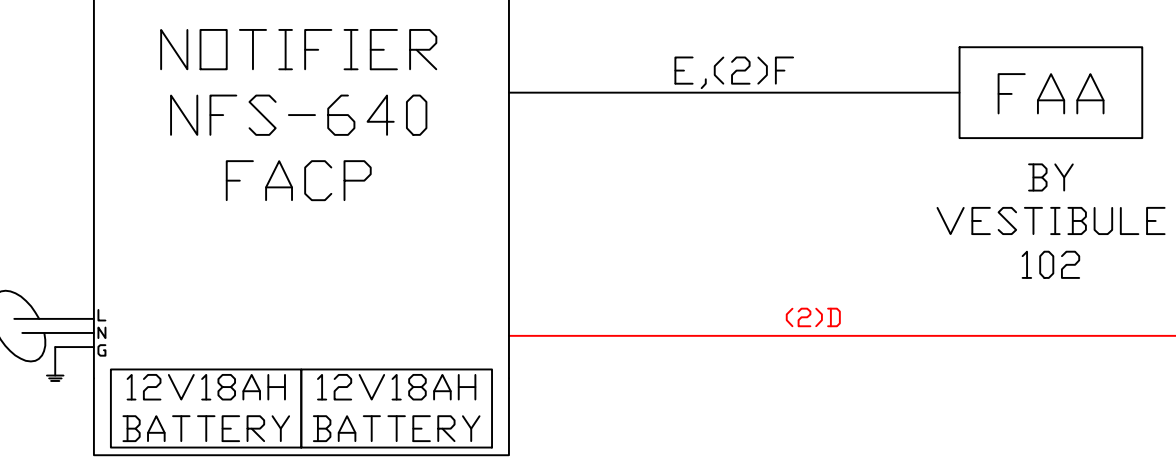
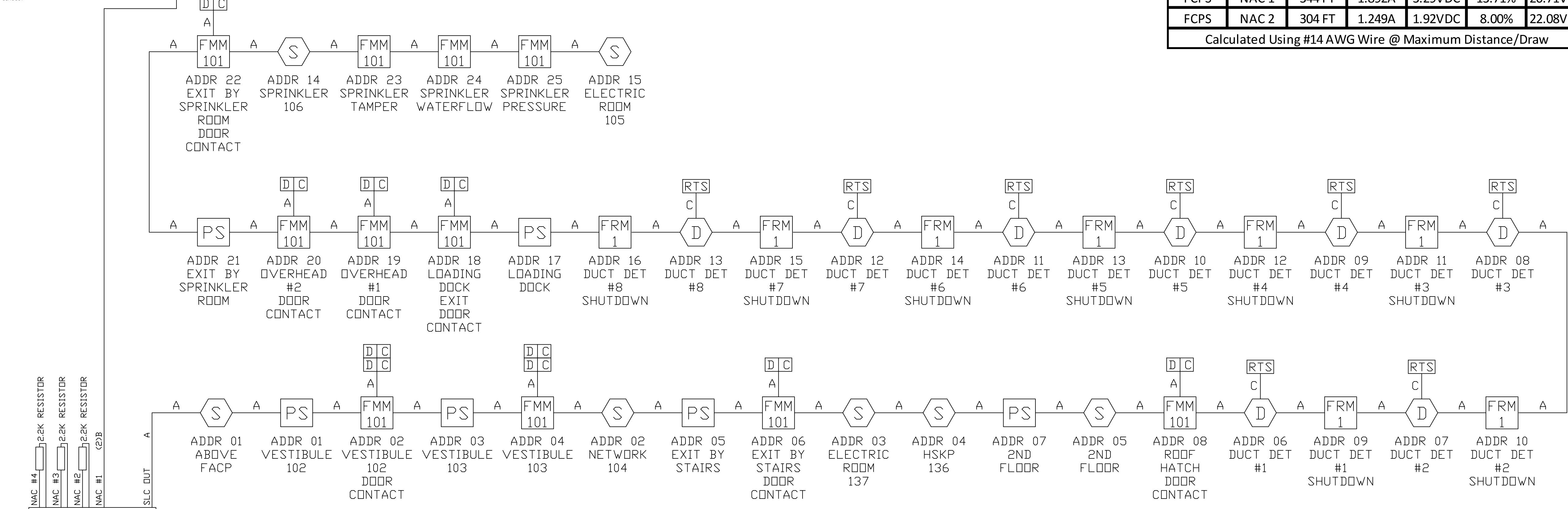

- LEGEND**
- PULL STATION
  - SMOKE DETECTOR
  - DUCT DETECTOR
  - REMOTE TEST STATION
  - DOOR CONTACT
  - RELAY MODULE
  - MONITOR MODULE
  - STROBE  
(XX NOTES CANDELA)  
(C NOTES CEILING MOUNTED UNIT)
  - HDN/STROBE  
(XX NOTES CANDELA)  
(C NOTES CEILING MOUNTED UNIT)
  - REMOTE ANNUNCIATOR

- WIRE LEGEND**
- A 2 COND #16/#14/#12 AWG TWISTED PAIR FPL CABLE
  - B 2 COND #14 AWG FPL CABLE
  - C 3 COND #18 AWG FPL CABLE
  - D 1 CAT5 CABLE
  - E 2 COND #18 AWG TWISTED PAIR FPL CABLE
  - F 1 COND #18 AWG TWISTED SHIELDED FPL CABLE

**DEVICE ADDRESSES:**  
EACH DEVICE MUST BE LABELED WITH THE LOOP AND SLC ADDRESS.  
DEVICE EXAMPLE: L1D001 MODULE EXAMPLE: L1M001  
IMPORTANT! DUPLICATE ADDRESSES BETWEEN DEVICES AND MODULES ARE NOT AN ERROR. NOTE: PULL STATIONS ARE IDENTIFIED AS MODULES BY THE FIRE ALARM CONTROL PANEL.

**INSTALLATION NOTES:**

FIELD WIRING SHALL BE INSTALLED FOLLOWING THE CURRENT EDITION OF NFPA 70: NATIONAL ELECTRIC CODE(2014), ALL APPLICABLE MUNICIPAL, COUNTY, & STATE CODES, REQUIREMENTS, AND REGULATIONS, AS WELL AS ALL MANUFACTURER GUIDELINES FOR INSTALLATION.

CONTROL PANELS, DEVICES, AND ALL OTHER SYSTEM COMPONENTS SHALL BE INSTALLED FOLLOWING THE CURRENT EDITION OF NFPA 72: NATIONAL FIRE ALARM AND SIGNALING CODE(2013), ALL APPLICABLE MUNICIPAL, COUNTY, & STATE CODES, REQUIREMENTS, AND REGULATIONS, AS WELL AS ALL MANUFACTURER GUIDELINES FOR INSTALLATION.

THE INSTALLER SHALL FOLLOW CORRECT CONDUCTOR POLARITY, INDICATED CIRCUIT DIVISIONS, PROPER GROUNDING AND SHIELDING WITHOUT EXCEPTION. IMPROPER INSTALLATION CAN RESULT IN INTERFERENCE, TRANSIENT VOLTAGE, OR SHORT CIRCUITS CAUSING UNDESIRABLE OPERATION OR DAMAGE TO THE CONTROL PANEL, DEVICES AND ANY OTHER INTEGRATED COMPONENTS.

THE GAUGE OF WIRE USED FOR THE SLC LOOP (IDENTIFIED AS "A" ON THIS PRINT), SHALL BE DETERMINED BY THE INSTALLER FOLLOWING GUIDELINES AND LIMITATIONS SET FORTH BY THE MANUFACTURER (NOTIFIER DOCUMENT #51253, INTELLIGENT CONTROL PANEL SLC WIRING MANUAL). THE SLC WIRING RISER IS SHOWN DIAGMATICALLY ONLY TO ALLOW FOR VARIANCES IN ACTUAL WIRE DISTANCE, DEVICE PLACEMENT AND STRUCTURAL OR ENVIRONMENTAL REQUIREMENTS.

ANY T-TAPPING OF SLC WIRING SHALL FOLLOW ALL REQUIREMENTS IN NOTIFIER DOCUMENT #51253, INTELLIGENT CONTROL PANEL SLC WIRING MANUAL.

WIRE FOR THE NOTIFICATION APPLIANCE CIRCUITS (IDENTIFIED AS "B" ON THIS PRINT), SHALL FOLLOW THE SPECIFIC REQUIREMENTS OF THE WIRING LEGEND. THIS WAS DETERMINED BY THE AVAILABLE DIMENSIONED OR SCALED FLOOR PLAN DEVICE LAYOUT. PLEASE REFERENCE THE VOLTAGE DROP CALCULATIONS LOCATED ON PRINT FA-3 FOR DISTANCE LIMITATIONS. THE INDICATED DISTANCES IN THE VOLTAGE DROP CALCULATIONS FOR EACH CIRCUIT SHALL BE CONSIDERED THE MAXIMUM LENGTH. ANY DISTANCES EXCEEDING THOSE IN THE VOLTAGE DROP CALCULATIONS MUST BE BROUGHT TO THE ATTENTION OF NORRIS INC. TO ASSURE PROPER FUNCTIONALITY AND COMPLIANCE OF THE NOTIFICATION APPLIANCE.

THIS SYSTEM MEETS NFPA REQUIREMENTS FOR OPERATION AT 32-120°F AND A RELATIVE HUMIDITY OF 91-95% AT 87-93°F. HOWEVER, THE USEFUL LIFE OF THE SYSTEMS STANDBY BATTERIES AND THE ELECTRONIC COMPONENTS MAY BE ADVERSELY AFFECTED BY EXTREME TEMPERATURE RANGES AND HUMIDITY. THEREFORE, IT IS RECOMMENDED THAT THIS SYSTEM AND ITS PERIPHERALS BE INSTALLED IN AN ENVIRONMENT WITH A NORMAL ROOM TEMPERATURE OF 60-80°F.

**DESIGN NOTES:**

SYSTEM DESIGN PERFORMANCE AND COMPLIANCE WITH ALL APPLICABLE CODES AND REQUIREMENTS IS THE RESPONSIBILITY OF THE DESIGNING ENGINEER. PROPER INSTALLATION OF THIS SYSTEM AND ITS COMPONENTS IS THE RESPONSIBILITY OF THE INSTALLING CONTRACTOR. ANY ALTERATIONS, CHANGES, OR DEFICIENCIES MUST BE BROUGHT TO THE ATTENTION OF THE DESIGNING ENGINEER.

NORRIS INC. ASSUMES NO RESPONSIBILITY FOR ERRORS IN SYSTEM DESIGN OR INSTALLATION, AS WELL AS ANY COSTS ASSOCIATED WITH CORRECTING THESE ERRORS, IF ANY EXIST, UNLESS SYSTEM DESIGN OR INSTALLATION WAS PERFORMED BY NORRIS INC.

SUBMITTAL	DATE: 07/23/2015
FIRE ALARM WIRING RISER	
PROJECT NAME	BY: JRS
LL BEAN CHESHIRE BUILDING	CK: DG
43 NORTHPORT DRIVE	SCALE: NONE
PORTLAND, MAINE 04103	SHEET: FA-1
 Prepared For Tomorrow; Delivered Today 2257 BROADWAY, SOUTH PORTLAND, MAINE	