

RIGHT SIDE ELEVATION 1/4"=1'-0" **A**

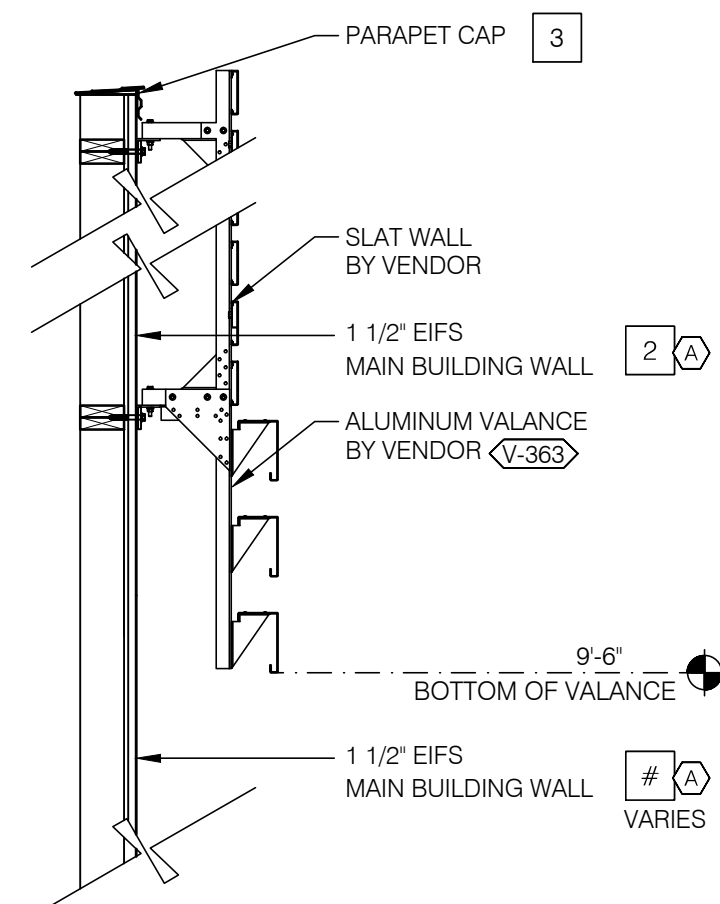

SLAT WALL COLOR TRANSITION N.T.S. **I**

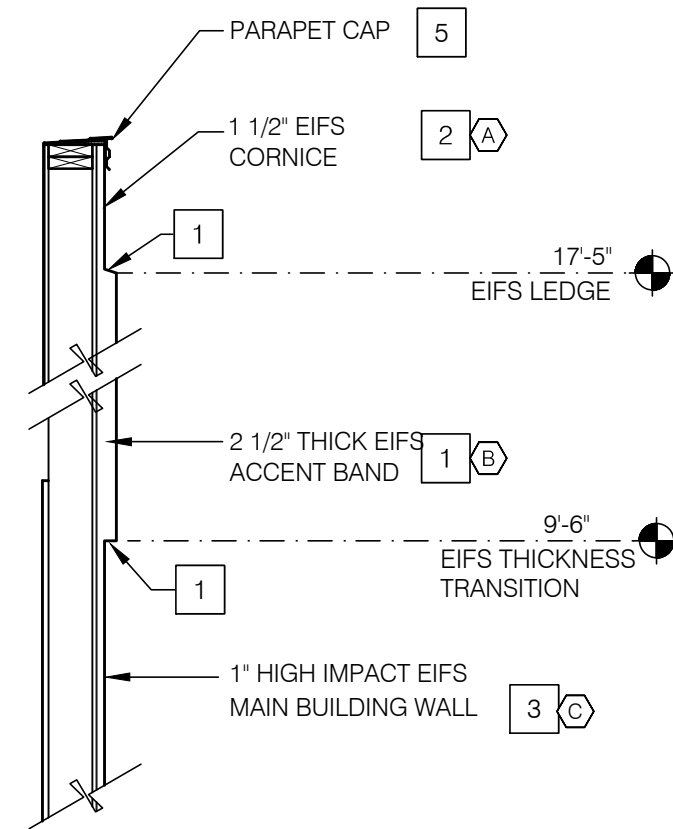

EIFS THICKNESS COLOR TRANSITION N.T.S. **G**

MISCELLANEOUS
 A. SEE SHT A1.1 "WINDOW TYPES" FOR WINDOW ELEVATIONS.
 B. SEE SCOPE OF WORK FOR RESPONSIBILITIES.
 C. "HIGH IMPACT" MESH SHALL BE USED WHERE NOTED (C/D).
 D. THE PAINT COLORS SHOWN ARE COLOR REFERENCES FOR THE EIFS. SUPPLIER E. EIFS. TEXTURE SHALL BE FINE.

SEALERS (REFER TO SPECS):
 A. SEALANT AT ALL WALL AND ROOF PENETRATIONS.
 B. SEALANT AT ALL WINDOW AND DOOR FRAMES AT HEAD AND JAMB. DO NOT SEAL SILL @ WINDOWS.
 C. APPLY NEOPRENE GASKET (CONT.) BETWEEN BUILDING & CANOPY/TRELLIS.

LEGEND:
 A. DENOTES 2 1/2" THICK EIFS

***CRITICAL* DIMENSIONS:**
 A. REQUIRED CLEAR OPENING WIDTH TO ENSURE COORDINATION WITH STANDARD SIGNAGE/ BUILDING ELEMENTS DIMENSIONS.

GENERAL NOTES **F**

QTY	ITEM DESCRIPTION	ELEC
V-350 1	TACO BELL DRIVE THRU CANOPY	X
V-348 1	TACO BELL "BUILDING ACCENT" - OPTIONAL SHADING & LED LAMPING.	X
V-363 1	SLAT WALL SYSTEM	

* REQUIRES ELECTRICAL CONNECTION. SEE ELECTRICAL PLANS.

CANOPY AND BLDG. ACCENT SCHED. N.T.S. **E**

QTY	ITEM DESCRIPTION	ELEC
V-349 3	TACO BELL LETTERS 12" HIGH, WHITE, FLAT FACED	X
V-322 3	TACO BELL 'BELL' SIGN 4'-10 1/2"W x 4'-6 1/4"H	X

LED LAMPING.

SIGN SCHEDULE N.T.S. **C**

SYMBOL	AREA	MANUFACTURER	COLOR	ALTERNATE MFR.	ALTERNATE COLOR	CONTACT INFORMATION
1	ACCENT COLOR COLOR	SHERWIN WILLIAMS	SW 2823 'ROOKWOOD CLAY'	LOTUSAN	NA08-0010	SHERWIN WILLIAMS: BRAD HARRINGTON, 216-341-5558 X115 (PHONE), BRAD.E.HARRINGTON@SHERWIN.COM
2	WALL COLOR BEHIND SCREEN WALL	SHERWIN WILLIAMS	SW 6831 'CLEMATIS'			
3	MAIN BUILDING COLOR	SHERWIN WILLIAMS	SW 6122 'CAMEL BACK'	LOTUSAN	NA08-0011	EIFS CONTACT: STO CORP.: CHUCK DUFFIN, 940-894-2092 (PHONE), 940-894-2095 (FAX), CDUFFIN@STOCORP.COM OWNER REPRESENTATIVE WILL IDENTIFY IF LOTUSAN PAINT WILL BE USED.
4	SLAT WALL AND VALANCE COLOR	VENDOR	SW 7034 'STATUS BRONZE' (EQUAL)			
5	PARAPET CAP COLOR	25 DUROLAST	MEDIUM BRONZE (FACTORY FINISH)	SHERWIN WILLIAMS	SW 7069 'IRON ORE'	DURO-LAST CURT JAFFEE, 800-356-6646 (PHONE), CJAFFEE@DURO-LAST.COM
6	STONE WALL	BORAL - VERSA STONE	TIGHT CUT - "PLUM CREEK"	CORONADO		VERSETTA STONE WALL: ASHLEY JOYCE, 770-645-4531 (PHONE) ALTERNATE: CORONADO: 1-800-847-8663
7	STOREFRONT WINDOWS	TBD	"DARK BRONZE"			
8	PIPE BOLLARDS	STREET SMART	YELLOW - 1/4" THICK PLASTIC COVER (US.POSTMAN.COM) OR EQUAL			DURO-LAST: LEE COBB, 800-434-3876 (PHONE)
9	PARAPET BACK ROOFING	DUROLAST	THE COLOR SHALL BE FACTORY COLORED "TAN." EQUAL ALTERNATE ALLOWED.			

EXTERIOR FINISH SCHEDULE **H**

- 1 BUILDING SIGN. SEE SCOPE OF WORK.
- 2 DRIVE THRU WINDOW. SEE SHEET A1.0 AND A1.1.
- 3 ROOF BEYOND.
- 4 STOREFRONT TYPICAL. GLASS TO BE SOLARBAN 60 STARRPHIRE ULTRA-CLEAR GLASS OR EQUIVALENT OF A TINT TO MATCH THE EXISTING WINDOWS.
- 5 DOUBLE DOOR.
- 6 SWITCH GEAR. PAINT TO MATCH WALL.
- 7 ARCHITECTURAL ALUMINUM VALANCE BY VENDOR.
- 8 LIGHT SCONCE. ALIGN BOTTOM OF FIXTURES MOUNTING BRACKET WITH CHANGE IN EIFS THICKNESS (CENTER OF BRACKET AT 9'-2").
- 9 ASSUME D/T LANE SURFACE IS 6" BELOW THE FINISH FLOOR. REFER TO GRADING & SITE PLAN.
- 10 2 1/2" EIFS TO TERMINATE AT 9'-6". PROVIDE 1 1/2" EIFS ABOVE THAT POINT. SLOPE TRANSITION AWAY FROM BUILDING 1:12. SEE DETAIL 20/A6.2.
- 11 EIFS (TYP). SEE 2 & 4/A6.2.
- 12 PARAPET COPING. IF DURO-LAST EDGE TRIM IS USED. USE THE DURO-LAST PRE-FINISHED EDGE TRIM. SEE DETAIL 2/A6.0.
- 13 CO2 FILLER VALVE & COVER. SEE DETAIL 5/A6.2 SIM.
- 14 EIFS REVEAL JOINT.
- 15 GAS SERVICE.
- 16 WALL SHALL BE FINISHED PRIOR TO INSTALLATION OF SWITCHGEAR.
- 17 SCUPPER, COLLECTOR, AND VERTICAL DOWNSPOUT 6" MIN. PAINT TO MATCH ADJACENT WALL.
- 18 OVERFLOW SCUPPER.
- 19 RTU BEYOND. PAINT TO MATCH MAIN BUILDING COLOR.
- 20 BREAK METAL COVER OVER WOOD STUDS TO MATCH STOREFRONT. SEE 3.4 & 7/A6.1
- 21 HIGH IMPACT EIFS. WHERE SHOWN ON ELEVATIONS. TOP EXTENT AT 5'-0". SEE 2/A6.2.
- 22 ALUMINUM SLAT WALL BY VENDOR.
- 23 BOLLARD
- 24 DUROLAST SINGLE MEMBRANE ROOFING OR EQUAL.
- 25 IF THE DURO LAST PARAPET CAP TRIM IS USED IT SHALL NOT BE PAINTED.
- 26 RETURN ALUMINUM LOUVERS BACK TO FACE OF BUILDING.
- 27 HOSE BIB. SEE DETAIL 8/A6.2.
- 28 TRANSITION OF 2 1/2" EIFS TO 1 1/2" EIFS. SEE DETAIL 19/A6.2.

KEY NOTES **D**

MARK D. MCCLUGGAGE AIA, CCS
 1823 E. Douglas Wichita, KS 67211
 WWW.MDM.COM
 Fax: (316) 265-5846
 MAINE LIC # PRC2323

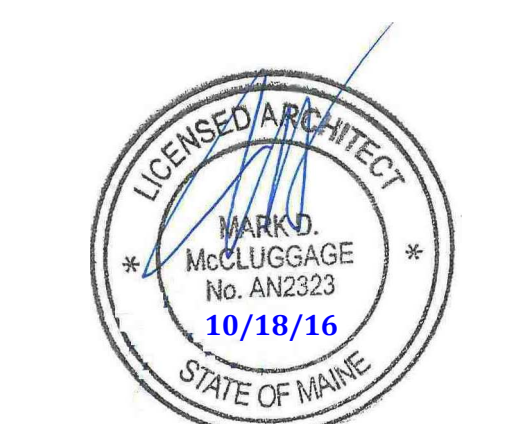

15034.000

REVISION 2 10/14/16

CONTRACT DATE: 07.06.2016
 BUILDING TYPE: CONVERSION
 PLAN VERSION: FEBRUARY 2015
 SITE NUMBER: XXX-XXX
 STORE NUMBER: XXXXX

TACO BELL

1363 WASHINGTON AVE.
 PORTLAND, ME

CONVERSION
 LIVE MAS - MEDIUM40

EXTERIOR ELEVATIONS

A4.0

PLOT DATE: